



(19) **United States**

(12) **Patent Application Publication**

Market et al.

(10) **Pub. No.: US 2004/0104232 A1**

(43) **Pub. Date: Jun. 3, 2004**

(54) **INSULATED CARRIER**

Publication Classification

(75) Inventors: **Jason A. Market**, Winchester, VA (US);
Dale T. Maza, Stephenson, VA (US);
Robert J. Linney II, Winchester, VA (US)

(51) **Int. Cl.⁷** **B65D 21/02**

(52) **U.S. Cl.** **220/23.88**

Correspondence Address:
FOLEY AND LARDNER
SUITE 500
3000 K STREET NW
WASHINGTON, DC 20007 (US)

(57) **ABSTRACT**

An insulated carrier includes a substantially rigid frame and a plurality of members supported on the substantially rigid frame. The substantially rigid frame includes an insulating material and is configured to at least partially insulate containers held by the insulated carrier from ambient conditions. The plurality of members supported on the substantially rigid frame is configured to contact and support containers held by the insulated carrier. At least one of a heat dissipating characteristic and an abrasion resisting characteristic of the members is greater than a corresponding characteristic of the insulating material of the substantially rigid frame. An insulating cover may also be provided to receive the substantially rigid frame.

(73) Assignee: **Rubbermaid Commercial Products LLC**

(21) Appl. No.: **10/640,574**

(22) Filed: **Aug. 14, 2003**

Related U.S. Application Data

(60) Provisional application No. 60/402,950, filed on Aug. 14, 2002.

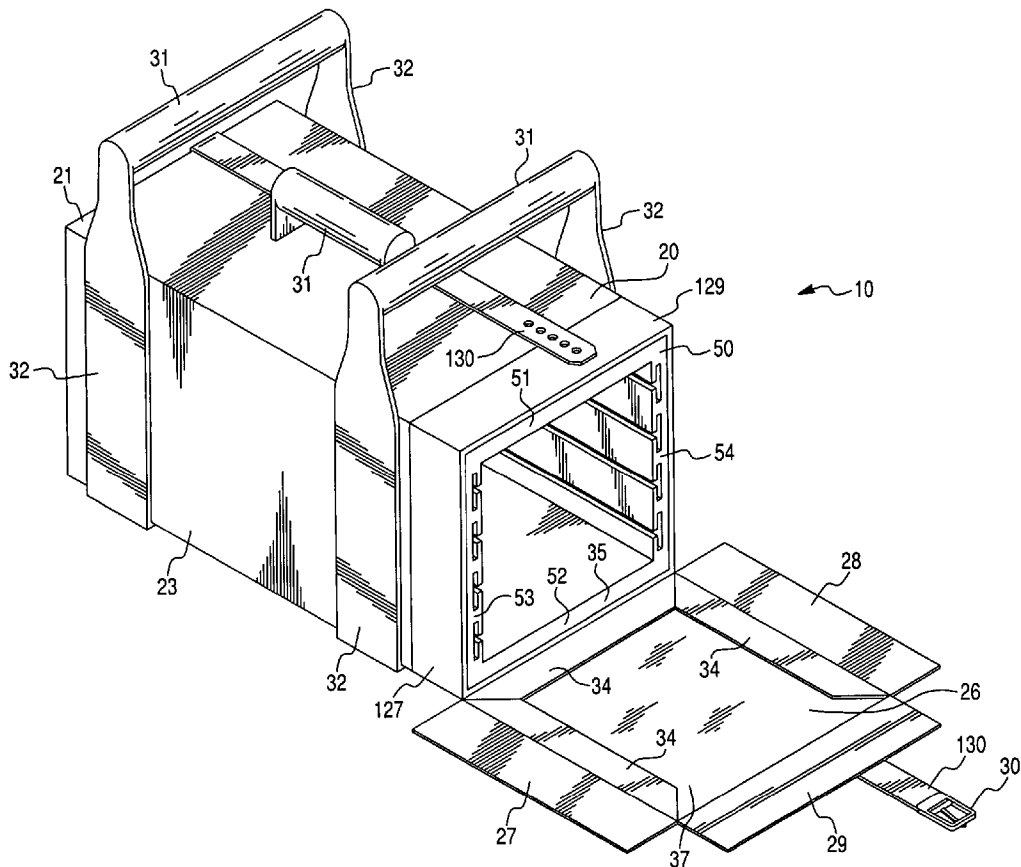

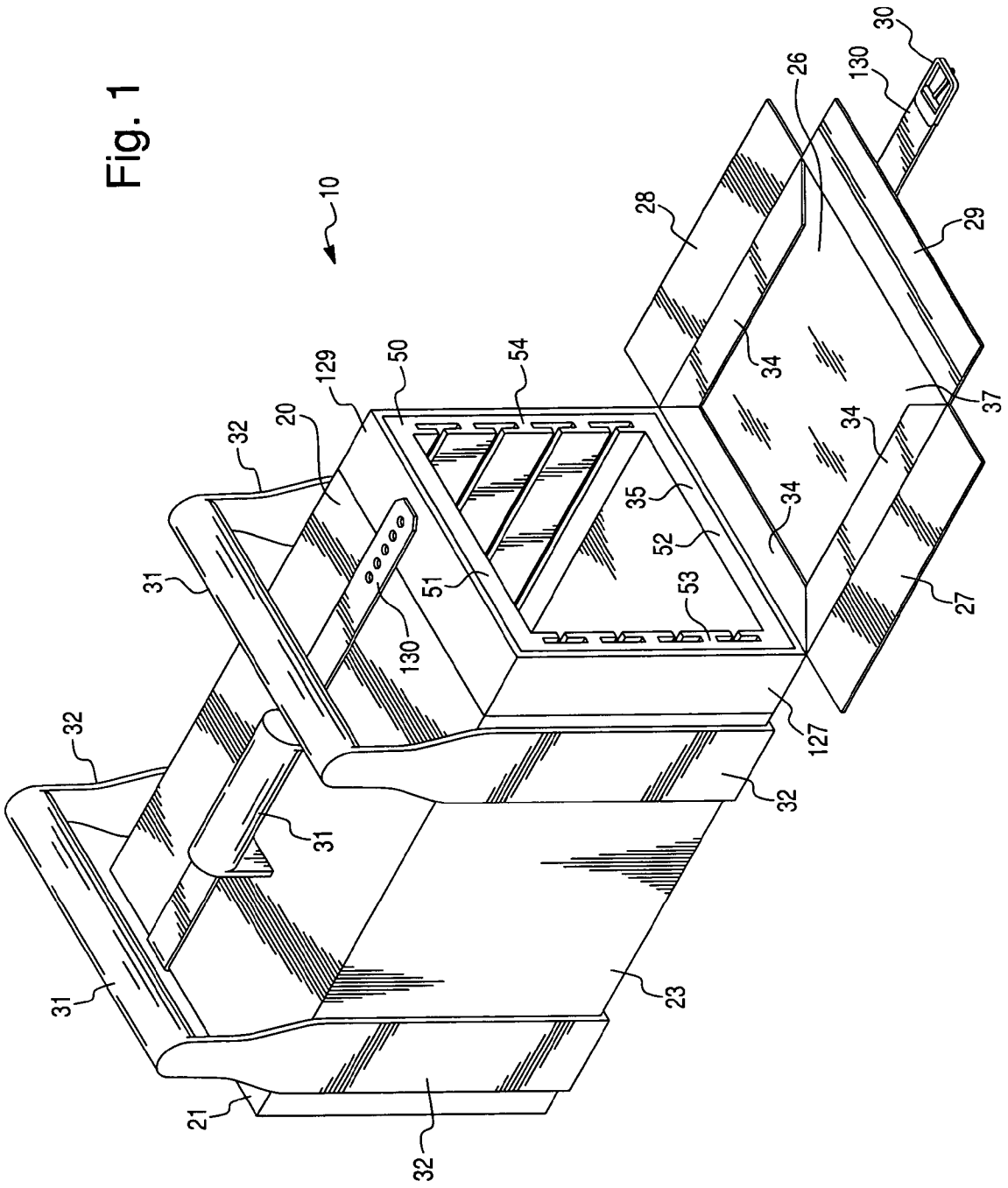

Fig. 1

Fig. 2

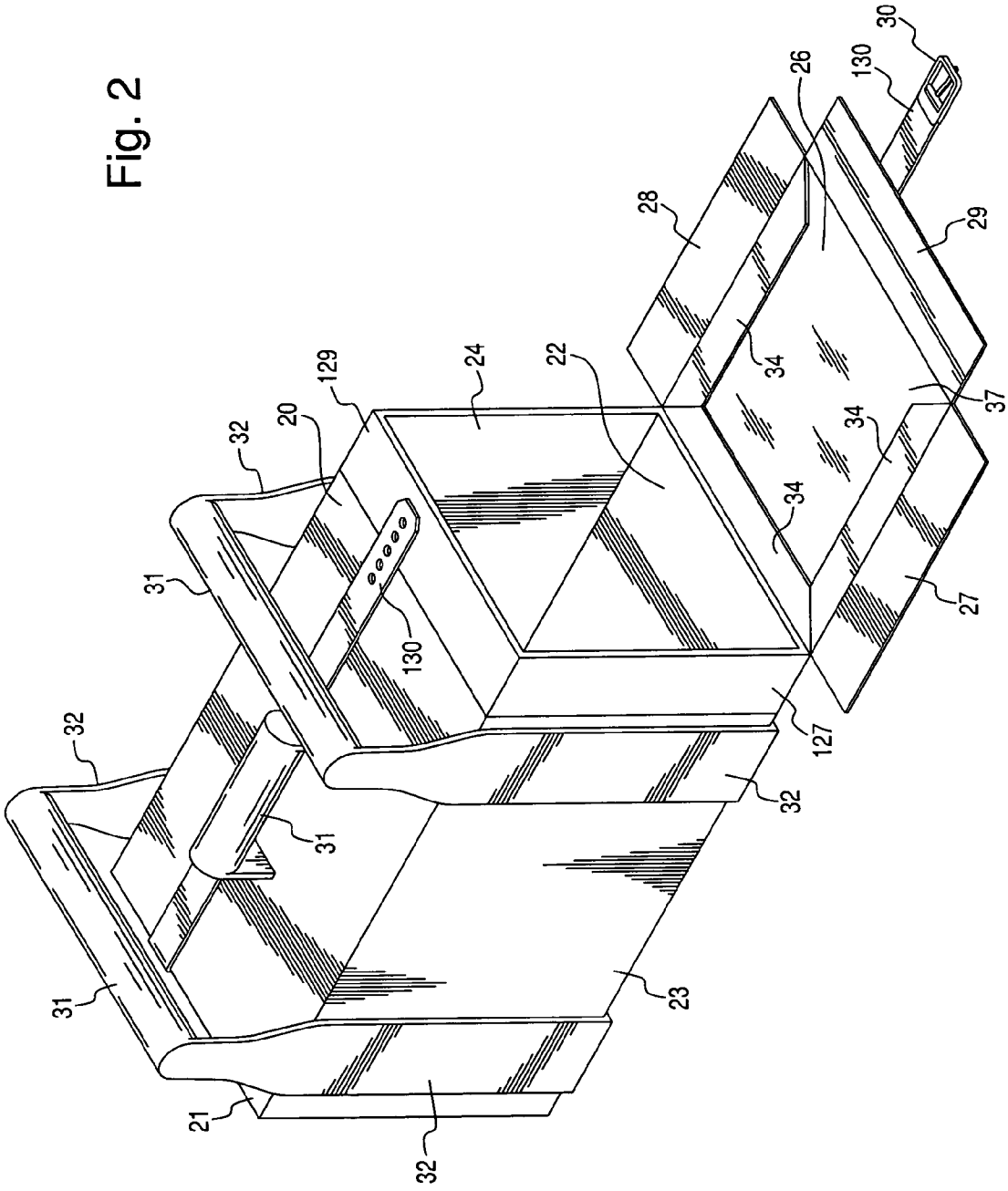

Fig. 3

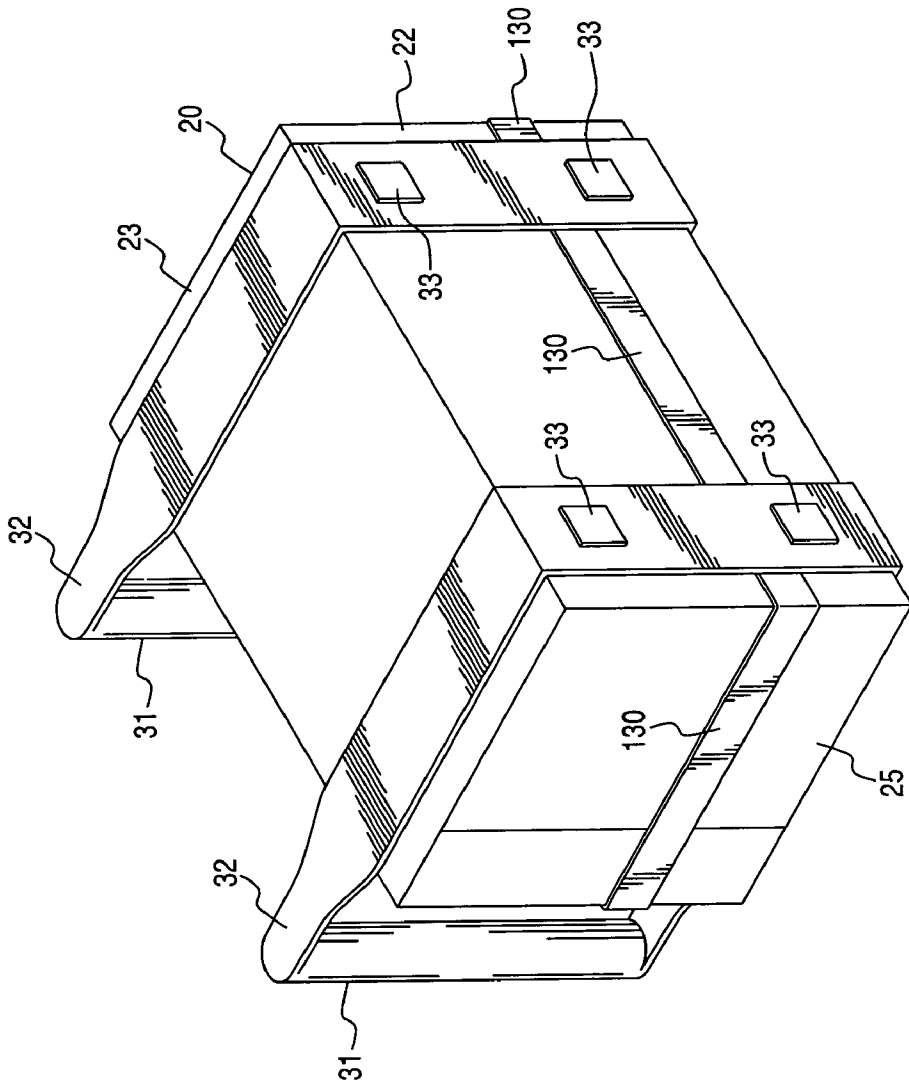

Fig. 4

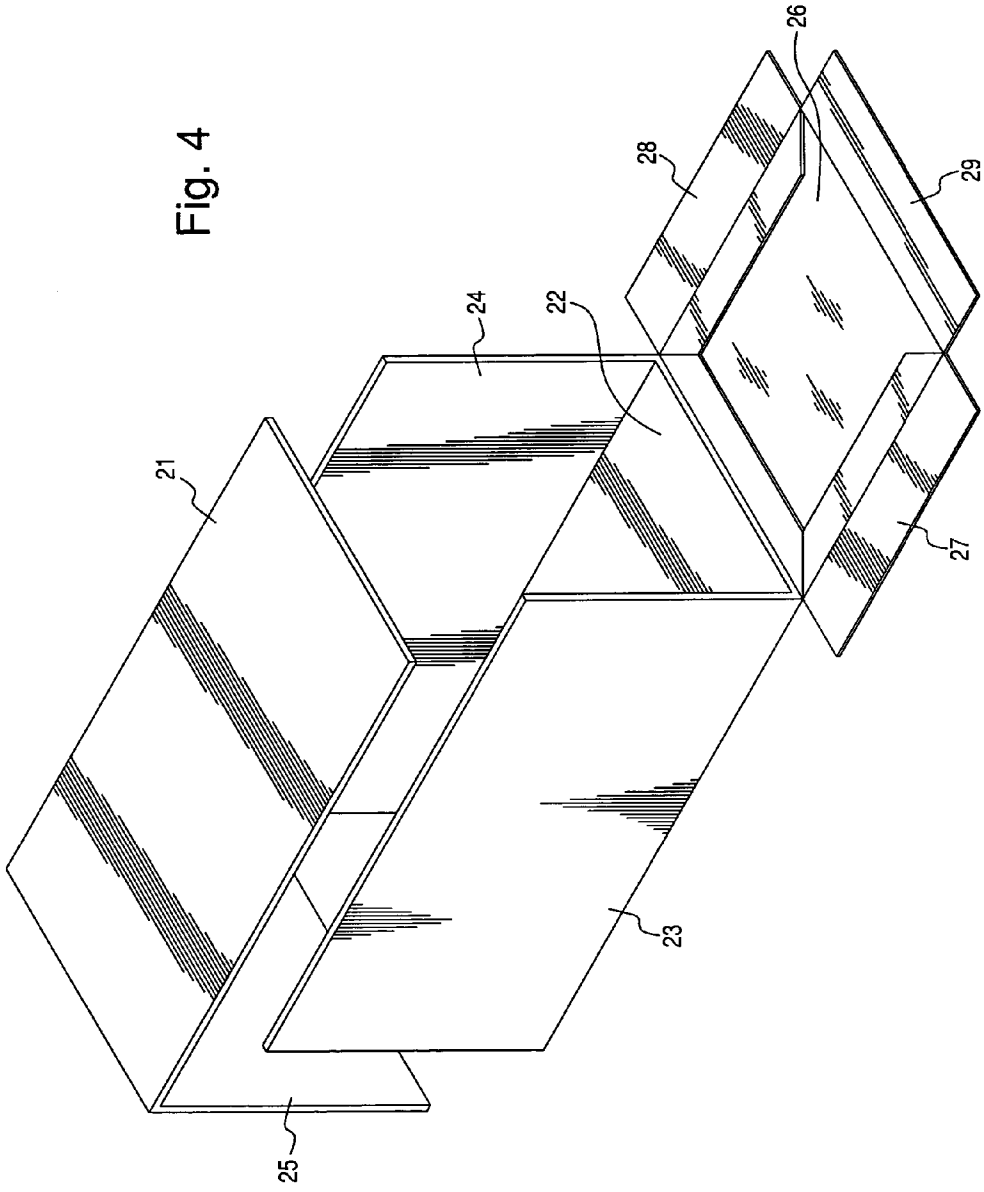

Fig. 5

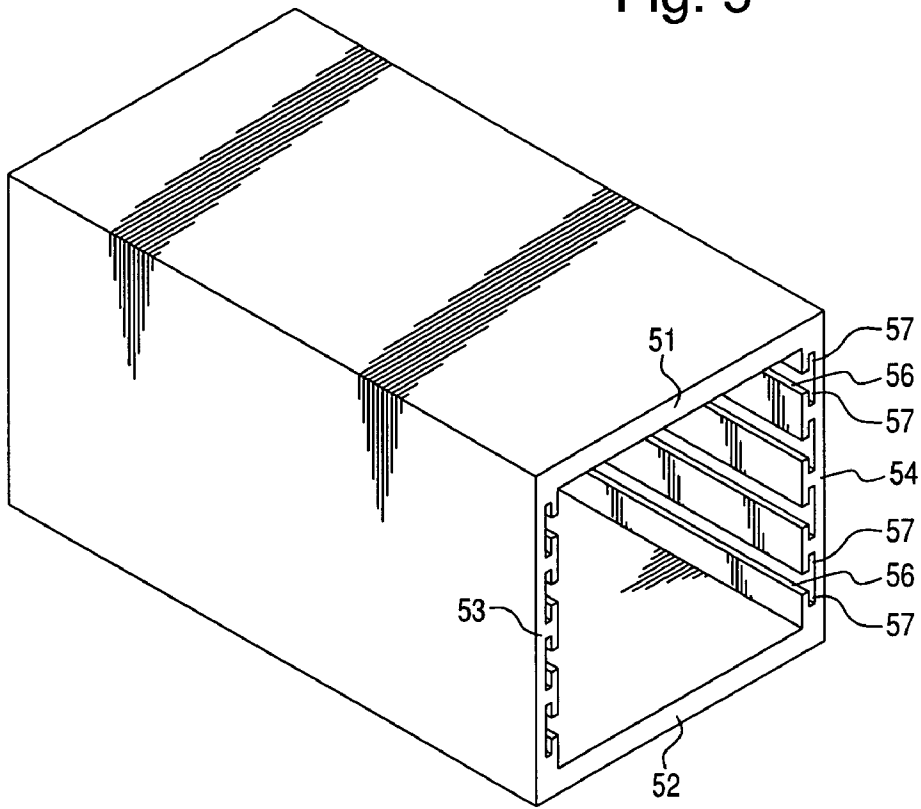

Fig. 6

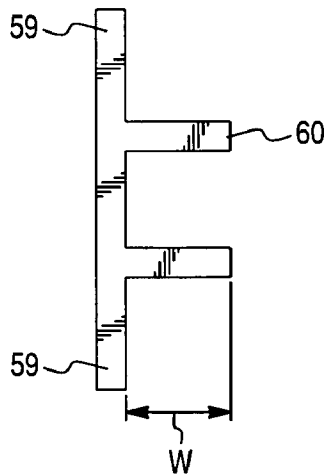

Fig. 7

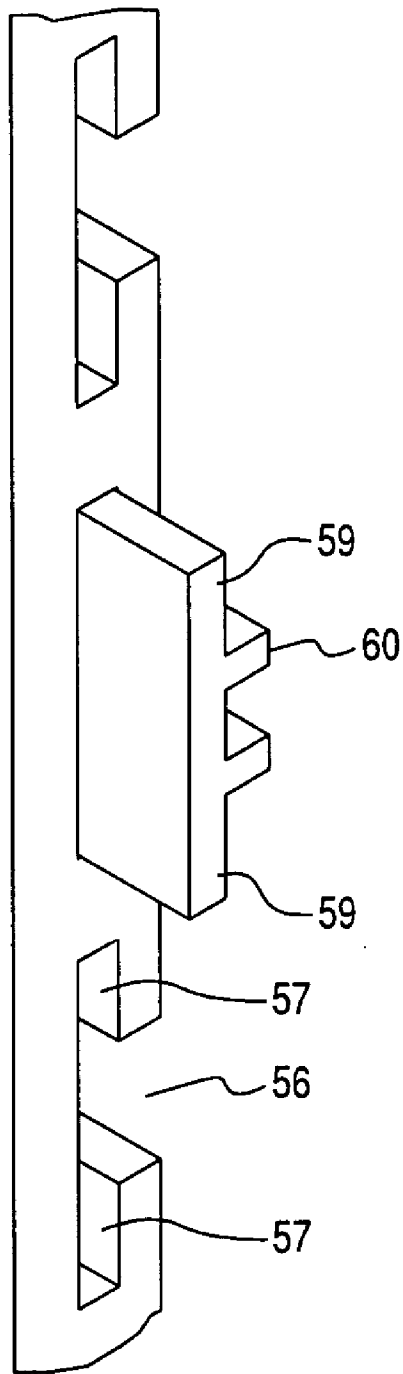

Fig. 8

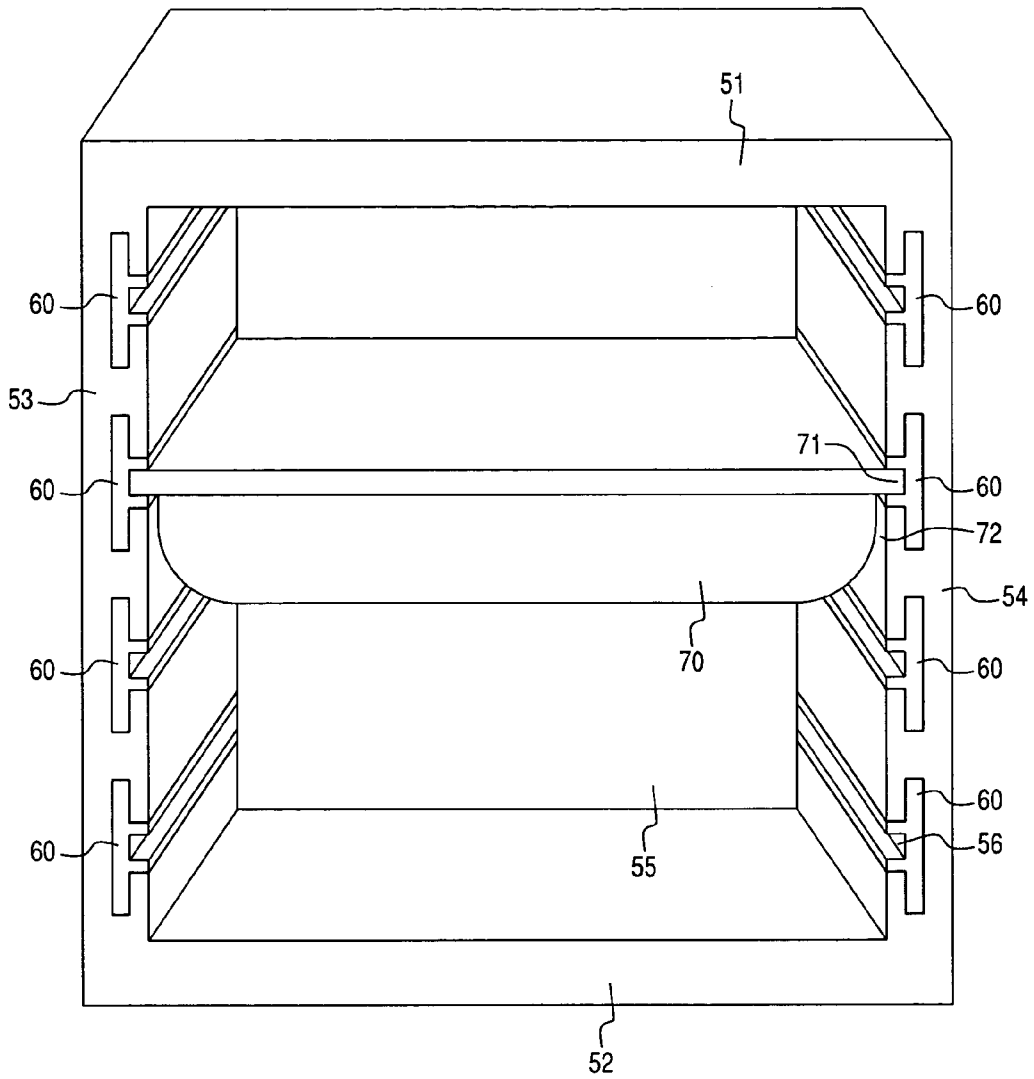

Fig. 9

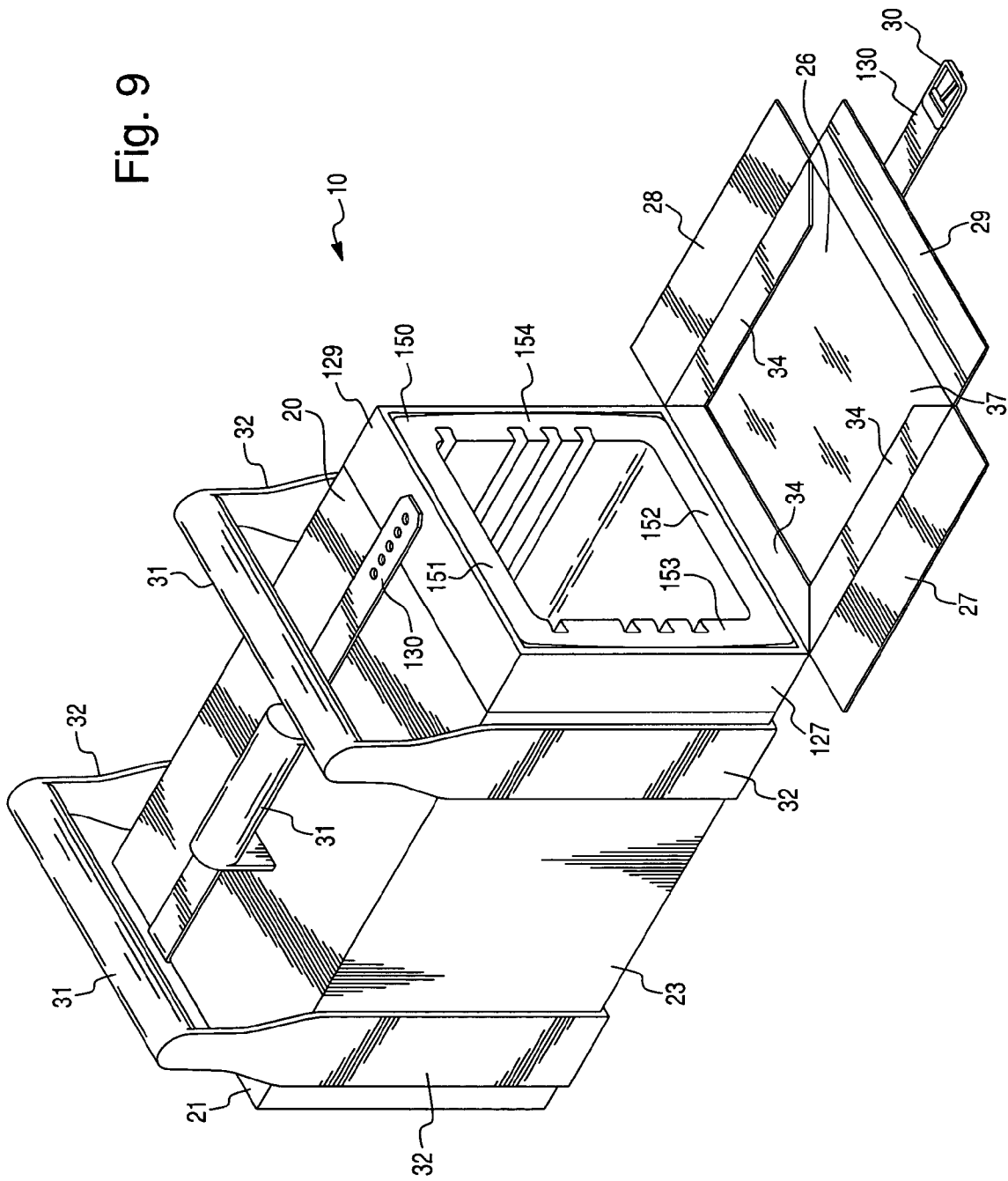

Fig. 10

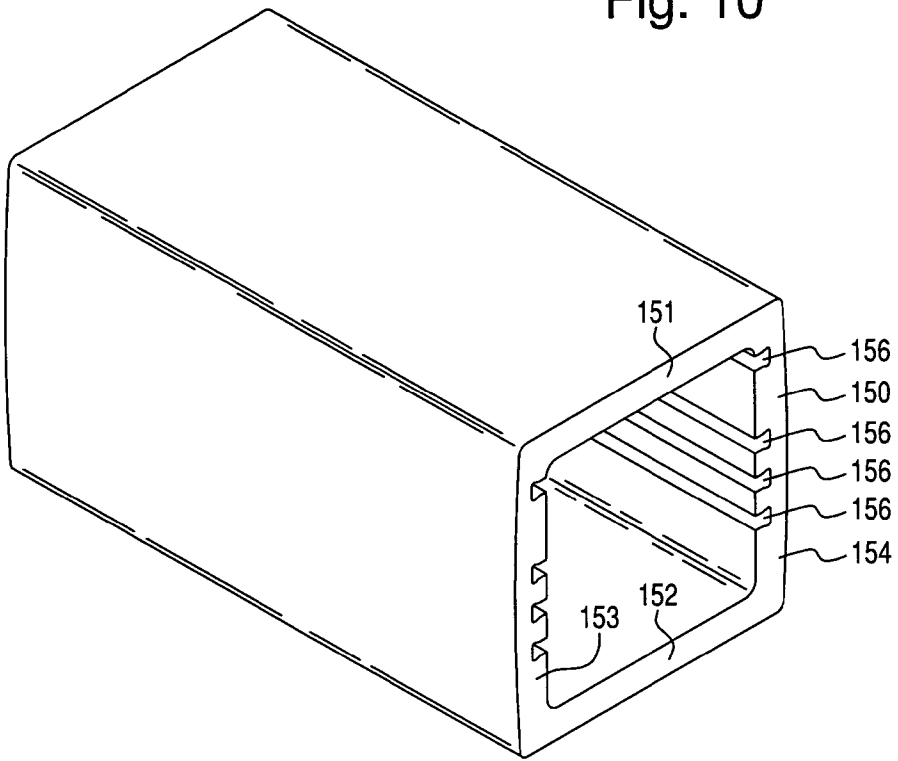

Fig. 11

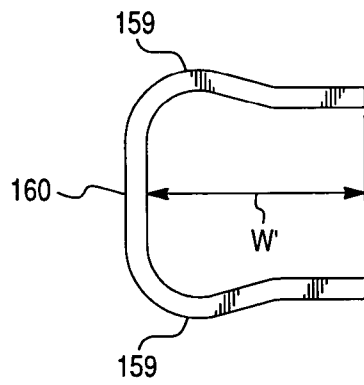

Fig. 12

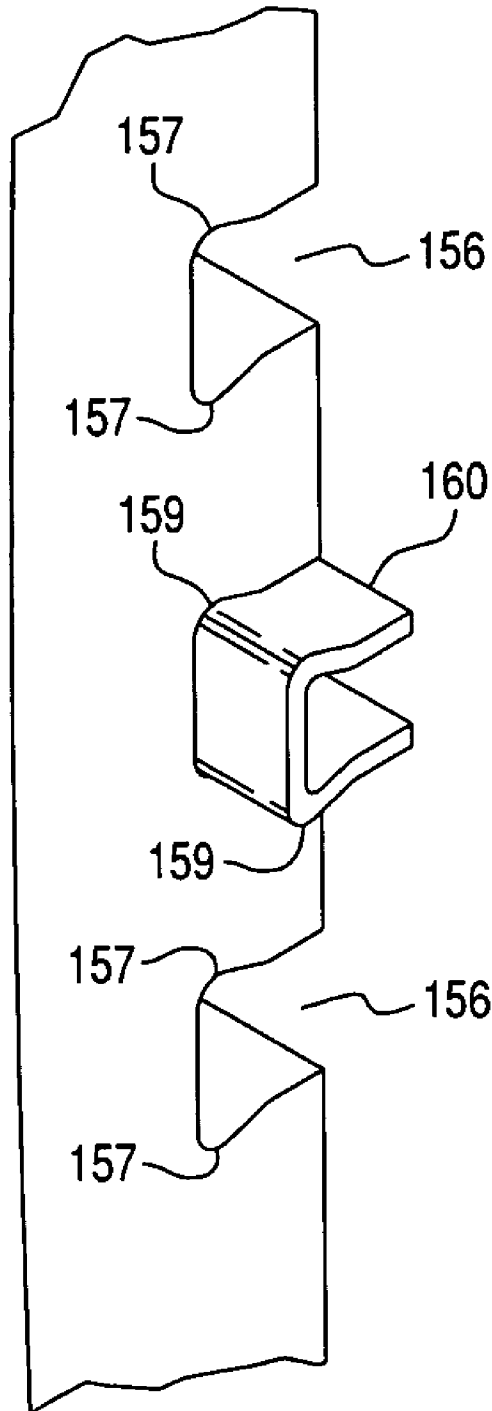
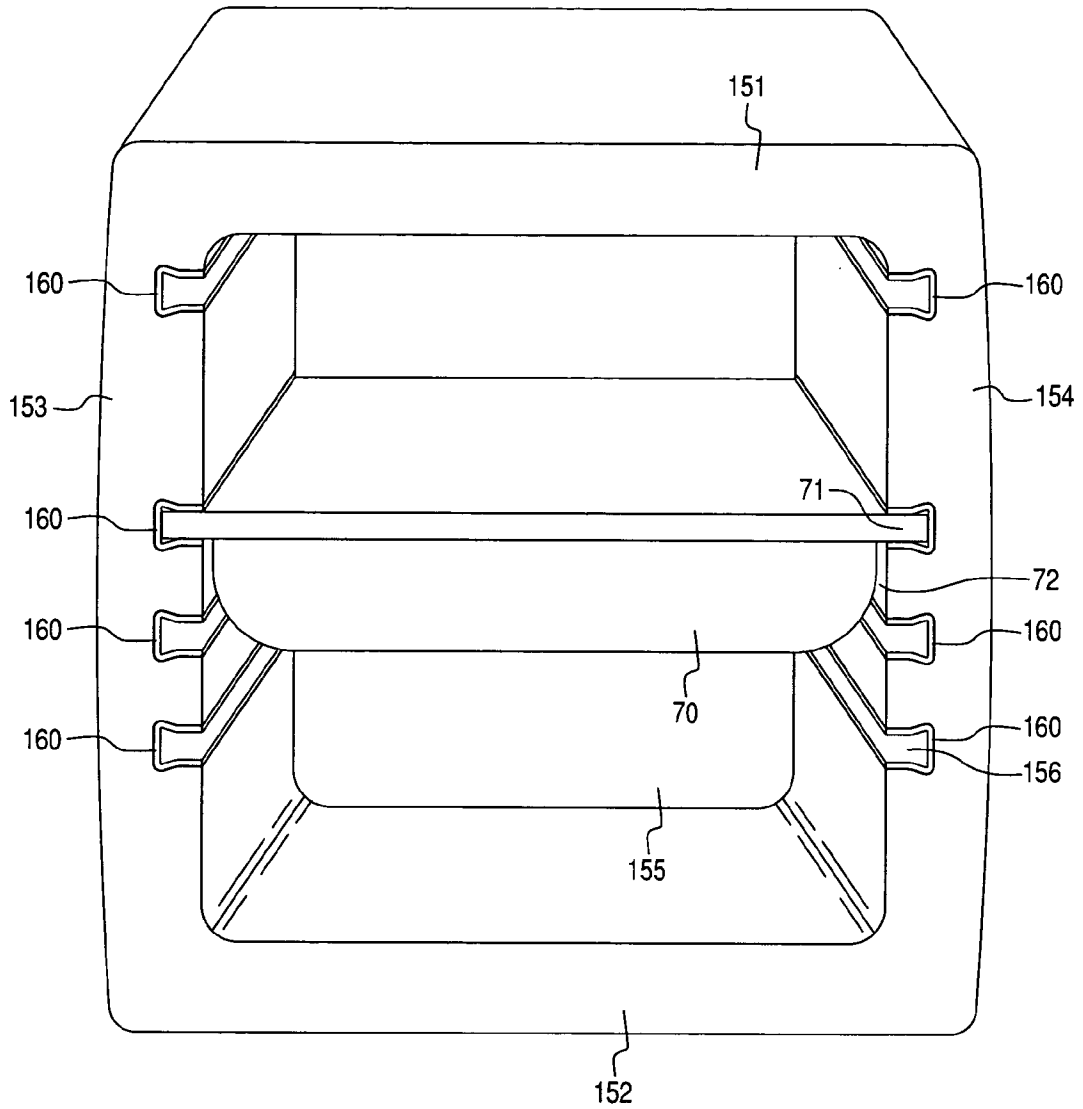

Fig. 13



INSULATED CARRIER

CROSS-REFERENCE TO RELATED APPLICATION

[0001] This application claims priority to U.S. Provisional Application Serial No. 60/402,950 filed on Aug. 14, 2002.

BACKGROUND OF THE INVENTION

[0002] 1. Field of the Invention

[0003] The present invention relates to an insulated carrier and, more particularly, to an insulated carrier for holding containers.

[0004] 2. Description of the Related Art

[0005] There are many varieties of insulated carriers currently on the market for transporting hot or cold food from one location to another. It is customary, especially in the catering industry, for food to be prepared in traditional "containers" (also referred to as "insert pans" or simply "food pans") and for those containers to then be placed inside insulated carriers for transport.

[0006] These insulated carriers may be soft-sided products. The insulated carriers may have internal support structure, such as a wire frame, placed within the soft-sided portion of the insulated carrier to provide added rigidity.

[0007] As several containers are often placed within one insulated carrier, the insulated carrier often becomes heavy and difficult to move. Even if an internal structure, such as a wire frame, is used the insertion, retention, and removal of containers from the wire frame can be difficult. Moreover, at least one of the wire frame and the container may be damaged when a container is inserted into, or removed from, the wire frame.

SUMMARY OF THE INVENTION

[0008] An aspect of the present invention relates to an insulated carrier for holding containers. The insulated carrier includes a substantially rigid frame including an insulating material, and a plurality of members supported on the substantially rigid frame. The substantially rigid frame is configured to at least partially insulate containers held by the insulated carrier from ambient conditions. The plurality of members supported on the substantially rigid frame are configured to contact containers held by the insulated carrier. At least one of a heat dissipating characteristic and an abrasion resisting characteristic of the members is greater than a corresponding characteristic of the insulating material of the substantially rigid frame.

[0009] Another aspect of the invention relates to an insulated carrier for holding containers, which includes a substantially rigid frame for receiving the containers, and a flexible cover for receiving the substantially rigid frame. The substantially rigid frame includes an insulating material and is configured to at least partially insulate the containers from ambient conditions.

[0010] It is to be understood that both the foregoing general description and the following detailed description are exemplary and explanatory only and are not restrictive of the invention, as claimed.

BRIEF DESCRIPTION OF THE DRAWINGS

[0011] The accompanying drawings, which are incorporated in and constitute a part of this specification, illustrate preferred embodiments of the invention and together with the description, serve to explain the principles of the invention.

[0012] FIG. 1 is a perspective view of a first preferred embodiment of an insulated carrier according to the present invention;

[0013] FIG. 2 is a perspective view of a flexible cover of the insulated carrier of FIG. 1;

[0014] FIG. 3 is a perspective view of an underside of the flexible cover of the insulated carrier of FIG. 1;

[0015] FIG. 4 is an exploded view of the flexible cover of the insulated carrier of FIG. 1;

[0016] FIG. 5 is a perspective view of a substantially rigid frame of the insulated carrier of FIG. 1;

[0017] FIG. 6 is an end view of a member of the insulated carrier of FIG. 1;

[0018] FIG. 7 is a partial perspective view of the insulated carrier of FIG. 1 showing a member projecting from a slot in the frame;

[0019] FIG. 8 is a perspective view of the substantially rigid frame of the insulated carrier of FIG. 1 having a plurality of members within slots.

[0020] FIG. 9 is a perspective view of a second preferred embodiment of an insulated carrier according to the present invention;

[0021] FIG. 10 is a perspective view of a substantially rigid frame of the insulated carrier of FIG. 9;

[0022] FIG. 11 is an end view of a member of the insulated carrier of FIG. 9;

[0023] FIG. 12 is a partial perspective view of the insulated carrier of FIG. 9 showing a member projecting from a slot in the frame; and

[0024] FIG. 13 is a perspective view of the substantially rigid frame of the insulated carrier of FIG. 9 having a plurality of members within slots.

DETAILED DESCRIPTION OF PREFERRED EMBODIMENTS

[0025] Reference will now be made in detail to presently preferred embodiments of the invention, which are illustrated in the accompanying drawings. An effort has been made to use the same reference numbers to refer to the same or like parts.

[0026] FIGS. 1 to 8 show a first preferred embodiment of an insulated carrier 10 according to the present invention. In this embodiment, the insulated carrier 10 preferably includes a substantially rigid frame 50 and a plurality of members 60 supported on the substantially rigid frame 50.

[0027] The substantially rigid frame 50 preferably has a rigidity that provides support for containers 70. For example, the substantially rigid frame can support not only

its weight and a plurality of containers 70 held by it, it can also withstand a load of up to about 150 lbs placed on a top wall 51 thereof.

[0028] In addition to the top wall 51, the substantially rigid frame 50 also preferably has a bottom wall 52, two sidewalls 53, 54, a rear wall 55, and a removable front wall (not shown). The front wall may rest in a space behind ridges 34 formed in the front wall 26 of the cover 20. Preferably at least the top wall 51, bottom wall 52, and two sidewalls 53, 54 are integral members. The substantially rigid frame 50 can be, for example, between about 19" and about 29" long, between about 11" and 19" wide, and between about 11" and 14" tall. More preferably, the substantially rigid frame 50 is 22" long, 15.125" wide, and 12.5" tall.

[0029] The sidewalls 53, 54 of the substantially rigid frame 50 preferably are configured to facilitate the support of the containers 70. In this preferred embodiment, the sidewalls 53, 54 contain slots 56 (shown in FIG. 5) for accommodating edges 71 of containers 70, as shown in FIG. 8. The slots 56 can be prescribed distances apart, thereby permitting the substantially rigid frame 50 to receive multiple containers 70 and/or a variety of sizes of containers 70. The slots 56 can include receiving grooves 57 (see FIG. 5).

[0030] The substantially rigid frame 50 also preferably at least partially insulates containers 70 held by the insulated carrier 10 from ambient conditions. The substantially rigid frame 50 can include a substantially insulating material. The insulating material preferably has an insulating value of at least R-Value of one. The substantially rigid frame 50 can be made entirely of the substantially insulating material. The insulating material can be, for example, a plastic such as polymeric foam or expanded polypropylene.

[0031] Members 60 are supported on the substantially rigid frame 50. The members 60 each can form a channel for receiving a portion of a container 70. The members 60 can be disposed within the slots 56 in the sidewalls 53, 54, as shown in FIG. 8. The members 60 are preferably formed as runners which are adapted to slide into and out of the slots 56, as shown in FIG. 7. The members 60 can include flanges 59 that slide tightly into receiving grooves 57 (shown in FIG. 5) formed in the back side of the slots 56 in the sidewalls 53, 54. The members 60 also may be shaped such that they will not become accidentally dislodged or bent due to the weight of the containers 70 they support. For example, the width W (shown in FIG. 6) of the portion of the members 60 that supports containers 70 may rest substantially against the upper and lower walls defining the slots 56, as shown in FIG. 8. As a result, the containers 70 will be supported by both the members 60 and by the upper and lower walls of the slots 56. In other words, the rigid members 60 enhance the support provided to the containers 70 by the slots 56.

[0032] The members 60 can be constructed of a material that will dissipate heat, such as metal. For example, the members 60 may be formed of extruded aluminum, stainless steel, other metals, polymers, etc. The members 60 preferably have a heat dissipating characteristic that is greater than a corresponding characteristic of the insulating material of the substantially rigid frame 50 which as, previously mentioned, is preferably formed of polymeric foam. Thus, the members 60 allow the insulated carrier 10 to handle containers 70 having high temperatures, while reducing the

likelihood of damage to the insulating material of the substantially rigid frame 50. The members 60 protect the sidewalls 53, 54 of the substantially rigid frame 50 from direct contact with the elevated temperatures of the containers 70. Each of the members 60 is adapted to spread throughout its length the heat absorbed from a container 70. As a result, the members 60 inhibit concentrated areas of heat from damaging the substantially rigid frame 50.

[0033] As a result of the members 60 preferably being harder than the substantially rigid frame, the members 60 preferably have an abrasion resisting characteristic that is greater than a corresponding characteristic of the insulating material of the substantially rigid frame 50. This enhanced abrasion-resisting characteristic of the members 60 protects the sidewalls 53, 54 of the substantially rigid frame 50 from abrasion. The members 60 act as a protective liner within the slots 56 used to support the hot or cold containers 70. The members 60 also can facilitate sliding the containers 70 into and out of the frame 50.

[0034] This preferred embodiment also can include a flexible cover 20 to receive the substantially rigid frame 50. More preferably, the flexible cover surrounds the substantially rigid frame 50. The flexible cover 20 is preferably a soft-sided product and preferably includes an insulating material that at least partially insulates the substantially rigid frame 50 from ambient conditions. For example, the flexible cover 20 can have an outer layer that could be formed of a combination of waterproof 1000 denier Cordra Plus or 1050 ballistic Nylon and an insulating layer of non woven polyester. Other materials could be used for the outer layer such as, for example, vinyl or woven materials (e.g., fabric). The flexible cover 20 also can have an inner layer, such as a reflective vapor barrier, e.g., a reflective polyester liner.

[0035] Preferably, the flexible cover 20 includes a top wall 21, a bottom wall 22 (shown in FIG. 2), two sidewalls 23, 24 (shown in FIG. 4), a rear wall 25 (also shown in FIG. 4), and a front wall 26. The front wall 26 may have side flaps 27, 28 and a top flap 29. The flaps 27, 28, 29 may include, for example, one portion of a Velcro connector that connects with another corresponding portion 127, 128, 129 of a Velcro connector affixed to a respective one of the walls 23, 24, 21. Although the embodiment shown in FIG. 4 depicts a two-piece cover 20, each of the walls (and associated flaps) of the cover 20 may be integrally formed as one continuous piece. Similarly, each of the walls and flaps could be individual pieces connected by any conventional means, e.g., sewing. Preferably the flexible cover 20 is between about 20" and about 30" long, between about 10" and about 20" wide, and between about 10" and 15" tall. More preferably, the cover is about 24" inches long, 16" inches wide, and 13.5" inches tall.

[0036] A clasp may also be provided to ensure closure of the carrier 10. For example, the clasp may have two mating portions, one affixed to the front wall 26 and another on the top wall 21. By way of further example, a buckle 30 may be connected to the front wall 26 and a corresponding belt (containing holes) 130 may be provided on the top wall 21. Alternatively, the belt 130 may include a nylon strap sewn to the top of the cover 20 and having a half of a conventional snap and a nylon strap sewn to the front of the cover 20 and having the other half of the snap (not shown). The front wall 26 may also include inner ridges 34 that will rest against a

front side **35** of the substantially rigid frame **50** when the carrier **10** is closed. In addition, the ridges **34** may be used to house an additional insulated sheet (not shown).

[0037] One or more handles **31** may be provided on the flexible cover **20**. In addition, the handles **31** may include straps **32** that are affixed to, or circumscribe, the flexible cover **20**, as shown in FIG. 3. Preferably the handles **31** extend substantially in a direction of a longitudinal length of the flexible cover **20**.

[0038] Rubber wear feet **33** may be affixed (e.g., by sewing, glue, etc.) to the bottom wall **22** of the flexible cover **20**. Moreover, the feet **33** may be provided on the straps **32** (as shown) or on another portion of the bottom wall **22**.

[0039] FIGS. 9-13 show a second preferred embodiment of an insulated container according to the present invention. Similar to the previously described embodiment, the substantially rigid frame **150** of the this embodiment is designed to fit within the cover **20** shown in FIGS. 2-4. Moreover, this embodiment may also include a clasp (e.g., buckle **30** and belt **130**) to maintain the container **110** in a closed state. Similarly, the container **110** may also contain feet **33** and handles **31** which may serve the same purpose as in the previously described embodiment.

[0040] In this embodiment, the substantially rigid frame **150** may be formed of the same materials as the previously described frame **50**. In addition, the substantially rigid frame **150** similarly has a top wall **151**, bottom wall **151**, and sidewalls **153**, **154**. However, as shown in FIG. 10, unlike the previously described frame **50**, the sidewalls **153**, **154** (and associated members **160**) of the frame **150** of this embodiment may be shaped differently, i.e., to have generally curved exterior surfaces which facilitate inserting the substantially rigid frame **150** into the cover **20**. Further, unlike the slots **56** of the previously described embodiment, the slots **156** of this embodiment do not contain grooves **57**. Rather, the slots are formed to have a substantially c-shaped cross-section.

[0041] As shown in FIG. 11, the peaks of the "C" in c-shaped shaped cross-section define receiving portions **157**. To releaseably engage the receiving portions **157**, members **160** are formed with substantially c-shaped cross-sections which are sized slide into the slots **156**, as shown in FIG. 12. As the peaks of the "C" in the c-shaped cross-section are wider than the cut-out portion thereof, the members **160** can only be removed from the frame **150** by sliding them along their length.

[0042] The cut-out portion of the c-shaped cross-section of the members **160** enable the members to have a rim receiving area of width W' . In addition, like the width W of the previously described embodiment, the width W' of this embodiment is adapted to receive a rim **71** of a container **70** such that the member **160** can support the container **70** in the carrier **110** while providing a gap **72** between the container **70** and the frame **150**, as shown in FIG. 13.

[0043] The present invention can provide lightweight, but rigid, food transportation carriers that allow individuals to transport food more easily. Moreover, as a result of the insulating aspects of the carriers, food placed in the carrier may be kept hot (or cold) while it is being transported.

[0044] Other embodiments of the invention will be apparent to those skilled in the art from consideration of the

specification and practice of the invention disclosed herein. It is intended that the specification and examples be considered as exemplary only, with a true scope and spirit of the invention being indicated by the following claims.

What is claimed is:

1. An insulated carrier for holding containers, the carrier comprising:

a substantially rigid frame including an insulating material, the substantially rigid frame being configured to at least partially insulate containers held by the insulated carrier from ambient conditions; and

a plurality of members supported on the substantially rigid frame and being configured to contact containers held by the insulated carrier, wherein at least one of a heat dissipating characteristic and an abrasion resisting characteristic of the members is greater than a corresponding characteristic of the insulating material of the substantially rigid frame.

2. The insulated carrier of claim 1, wherein the insulating material has an insulating value of at least R-Value of one.

3. The insulated carrier of claim 1, wherein the insulating material includes polymeric foam.

4. The insulated carrier of claim 1, wherein the substantially rigid frame includes a top wall, two sidewalls, and a bottom wall, and wherein the top wall, two sidewalls, and bottom wall are integral.

5. The insulated carrier of claim 1, wherein the substantially rigid frame includes two opposing sidewalls configured to receive the members.

6. The insulated carrier of claim 5, wherein the two opposing sidewalls have slots configured to receive portions of containers, and wherein the members are disposed on at least bottom portions of the slots.

7. The insulated carrier of claim 5, wherein the two opposing sidewalls have receiving grooves, and wherein the members have flanges that are received within the receiving grooves to connect the members to the sidewalls.

8. The insulated carrier of claim 5, wherein the two opposing sidewalls have slots configured to receive portions of containers, wherein the slots are substantially c-shaped in cross-section, wherein the slots comprise receiving portions, and wherein the members have cross-sections which are sized to releaseably engage the receiving portions.

9. The insulated carrier of claim 5, wherein each member forms a channel for receiving a portion of a container.

10. The insulated carrier of claim 9, wherein each channel shields the two opposing sidewalls from the portions of the containers.

11. The insulated carrier of claim 1, wherein each member is an elongated runner.

12. The insulated carrier of claim 1, wherein the insulating material includes polymers and each member is formed of metal.

13. The insulated carrier of claim 12, wherein each member is formed of extruded aluminum or stainless steel.

14. The insulated carrier of claim 1, wherein the insulating material includes polymers and each member is formed of polymers.

15. The insulated carrier of claim 1, wherein the heat dissipating characteristic of the members is greater than that of the insulating material that supports the members.

16. The insulated carrier of claim 1, wherein the abrasion resisting characteristic of the members is greater than that of the insulating material that supports the members.

17. The insulated carrier of claim 1, further comprising:

a flexible cover for receiving the substantially rigid frame and members.

18. The insulated carrier of claim 17, wherein the flexible cover is configured to surround the substantially rigid frame and members.

19. The insulated carrier of claim 17, wherein the flexible cover includes an insulating material that at least partially insulates the substantially rigid frame from ambient conditions.

20. The insulated carrier of claim 17, wherein the flexible cover includes handles extending from the flexible cover.

21. The insulated carrier of claim 17, wherein the flexible cover includes an interior reflective vapor barrier.

22. An insulated carrier for holding containers, comprising:

a substantially rigid frame for receiving the containers, the substantially rigid frame including an insulating material and being configured to at least partially insulate the containers from ambient conditions; and

a flexible cover for receiving the substantially rigid frame.

23. The insulated carrier of claim 22, wherein the flexible cover is configured to surround the substantially rigid frame.

24. The insulated carrier of claim 22, wherein the flexible cover includes an insulating material that at least partially insulates the substantially rigid frame from ambient conditions.

25. The insulated carrier of claim 22, wherein the flexible cover includes handles extending substantially in a direction of a longitudinal length of the flexible cover.

26. The insulated carrier of claim 22, wherein the flexible cover includes an interior reflective vapor barrier.

* * * * *