



- (51) International Patent Classification:
G05D 23/12 (2006.01)
- (21) International Application Number:
PCT/EP2017/058867
- (22) International Filing Date:
12 April 2017 (12.04.2017)
- (25) Filing Language: English
- (26) Publication Language: English
- (30) Priority Data:
PA201600226 15 April 2016 (15.04.2016) DK
- (71) Applicant: DANFOSS A/S [DK/DK]; Nordborgvej 81,
6430 Nordborg (DK).
- (72) Inventor: HAAS, Peter; Za humnami 732/49, 94901 Nitra
(SK).
- (74) Agents: WHITING, Gary et al.; L25, Nordborgvej 81,
6430 Nordborg (DK).
- (81) Designated States (unless otherwise indicated, for every
kind of national protection available): AE, AG, AL, AM,

AO, AT, AU, AZ, BA, BB, BG, BH, BN, BR, BW, BY, BZ, CA, CH, CL, CN, CO, CR, CU, CZ, DE, DJ, DK, DM, DO, DZ, EC, EE, EG, ES, FI, GB, GD, GE, GH, GM, GT, HN, HR, HU, ID, IL, IN, IR, IS, JP, KE, KG, KH, KN, KP, KR, KW, KZ, LA, LC, LK, LR, LS, LU, LY, MA, MD, ME, MG, MK, MN, MW, MX, MY, MZ, NA, NG, NI, NO, NZ, OM, PA, PE, PG, PH, PL, PT, QA, RO, RS, RU, RW, SA, SC, SD, SE, SG, SK, SL, SM, ST, SV, SY, TH, TJ, TM, TN, TR, TT, TZ, UA, UG, US, UZ, VC, VN, ZA, ZM, ZW.

- (84) Designated States (unless otherwise indicated, for every kind of regional protection available): ARIPO (BW, GH, GM, KE, LR, LS, MW, MZ, NA, RW, SD, SL, ST, SZ, TZ, UG, ZM, ZW), Eurasian (AM, AZ, BY, KG, KZ, RU, TJ, TM), European (AL, AT, BE, BG, CH, CY, CZ, DE, DK, EE, ES, FI, FR, GB, GR, HR, HU, IE, IS, IT, LT, LU, LV, MC, MK, MT, NL, NO, PL, PT, RO, RS, SE, SI, SK, SM, TR), OAPI (BF, BJ, CF, CG, CI, CM, GA, GN, GQ, GW, KM, ML, MR, NE, SN, TD, TG).

Published:
— with international search report (Art. 21(3))

(54) Title: THERMOSTAT DEVICE

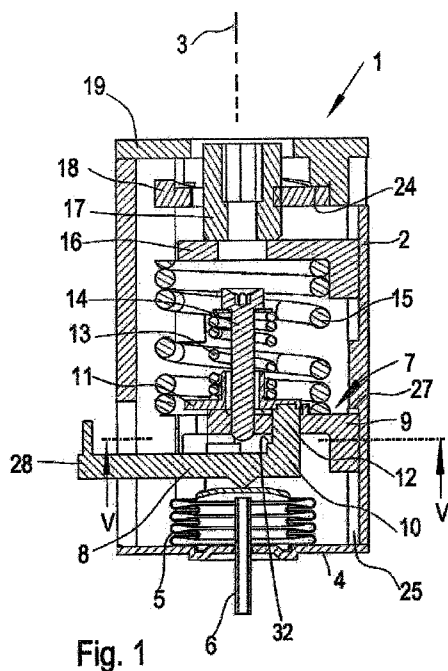

(57) Abstract: A thermostat device (1) is described comprising a housing (2) having a longitudinal axis (3), a bellows (5) arranged in said housing (2), an actuator arrangement (7) moveable in a direction parallel to said longitudinal axis (3), loaded by a force produced by said bellows (5) in a first direction and by a force of a spring arrangement (13, 15) in a second direction opposite to a first direction and comprising a first element (8) and a second element (9). Such linear thermostat should be of simple construction. To this end said spring arrangement (13, 15) comprises first spring (13) holding said first element (8) and said second element (9) together to move said first element (8) and said second element (9) like a one piece part until said second element (9) comes to rest against a stop (27).



Thermostat device

The present invention relates to a thermostat device comprising a housing having a longitudinal axis, a bellows arranged in said housing, an actuator arrangement movable in a direction parallel to said longitudinal axis, loaded by a force produced by said bellows in a first direction and by a force of a spring arrangement in a second direction opposite said first direction and comprising a first element and a second element.

Such a thermostat device is known from US 2 200 599. The movement of the actuator arrangement is a translational one without any rocking or swinging movement of parts. Therefore, such kind of thermostat device can be termed "linear thermostat".

The object underlying the present invention is to have a linear thermostat of simple construction.

This object is solved with a thermostat device as described at the outset in that said spring arrangement comprises a first spring holding said first element and said second element together to move said first element and said second element like a one piece part until said second part comes to rest against a stop.

Such a thermostat device needs few parts only which parts can be of simple form. Nevertheless, it is possible to realize a two stage movement of the first element. In a first stage of the movement the first element and the second element are moved together which is possible since they are held together by said first spring. Once the second element comes to rest against the stop, the movement of the first element can continue. During such movement the first element has to work against the force of the first spring.

In a preferred embodiment said first spring is pretensioned between said first element and said second element by means of a pretension element fixed to said second element. In other words, the first spring is arranged in a space

between the pretension element and the second element. Part of the first element is arranged in this space as well so that it is possible to press this part of the first element against the second element by means of the force of the first spring.

5

Preferably said pretension element is in form of a first pretension screw which is screwed into said second element. In this way it is possible to change or adjust the pretension of the first spring.

10 In a preferred embodiment said first element comprises a first part on a first side of the second element and a second part on a second side of said second element opposite said first side, one of said first part and said second part passing through said second element, wherein said first part and said second part are held together by forces generated by said bellows and said
15 first spring. The division of the first element in a first part and a second part simplifies the construction. Since these two parts are held together by forces only, it is not necessary to connect them by means of connection means although this would be possible as well. In this construction the second element is caught between the two parts of the first element.

20

Preferably said second part forms a bearing arrangement for a linear movement of said first element relative to said second element in a direction parallel to said longitudinal axis. This bearing arrangement can be formed, for example by a number of holes through which rod like extensions of the first
25 part are guided. For example, it is possible to use three symmetrical holes with axis of radial angle of 120° .

In a preferred embodiment said first element comprises an actuator arm extending out of said housing radially with respect to said longitudinal axis.

30 The actuator arm is designed for actuating a switch, which, for example, starts a compressor or stops the operation of the compressor by making or

breaking an electrical contact. The thermostat function is given by the set-up of the first element and the second element together with the actuator arm. Set-up of these elements together with the spring arrangement defines the thermostat function. The thermostat function can be changed by modification
5 of these elements.

Preferably said spring arrangement comprises a second spring acting on said second element. During the first stage of the movement the combined package of first element and second element are moved against the force of
10 the second spring. The driving force is in this case produced by the bellows.

In a preferred embodiment said first spring and said second spring are arranged concentrically. In other words, the first spring can, for example, be located radially inside the second spring. Such a construction saves space.
15

Preferably a pretension of said second spring is adjustable by a cam element which is mounted between said second spring and an end top of said housing. By adjusting the cam element it is possible to choose different working conditions for the second spring and to therefore choose different
20 switching points for the switch actuated by the actuator arm.

Preferably said cam element is mounted rotatably in said housing. In this case the position of the cam element in general can be kept unchanged. It is rotated only to choose different modes of operation. A rotational position of
25 the cam element can be adjusted from the outside without difficulties.

In a particular preferred embodiment said cam element comprises at least one working area, each working area comprising at least two different regions, differing in a pretension characteristic. Said regions can, for
30 example, have different heights of the respective cam, i.e. different thicknesses in a direction parallel to said longitudinal axis. When the cam

element bears against the end top of the housing, this means that the second spring is pretensioned in different ways. For example, it is possible to have a position "cold" and a position "warm". The working area is the whole area between positions cold and warm. It is possible to include as well a position "stop" into the working area. However, the position "stop" can be realized in another way, e.g. by some "notch" or other feature created on the surface of the cam element.

Preferably said cam element is in threaded connection with a second pretension screw, said second pretension screw being positioned between said cam element and said second spring. A second pretensioned screw allows for a fine adjustment of the pretension of the second spring.

In a preferred embodiment said housing comprises a predetermined number of grooves running parallel to said longitudinal axis, wherein said second element comprises guiding elements which are arranged in said grooves. These grooves define a path of movement for the second element.

Preferably said housing comprises three grooves spaced in circumferential direction by 120° . This allows for a symmetrical bearing of the second element.

Preferably said guiding elements are of V-shape in particular with rounded tips. The grooves can have a V-shape as well or it can have a semi-circular form or any form in between these two forms. The friction between the second element and the housing can be kept small.

A preferred embodiment of the invention will now be described in more detail with reference to the drawing, wherein:

- Fig. 1 shows a longitudinal section view of a thermostat device with an actuator arrangement in a first position,
- Fig. 2 a sectional view according to Fig. 1 with the actuator arrangement in a second position,
- 5 Fig. 3 a sectional view of the thermostat device according to Fig. 1 with the actuator arrangement in a third position,
- 10 Fig. 4 a perspective view of a cam element and
- Fig. 5 a sectional view V-V according to Fig. 1.

Fig. 1 schematically shows a thermostat device 1 which can also be termed as “linear thermostat”. The thermostat device 1 comprises a housing 2 having a longitudinal axis 3 comprising an end bottom 4. A bellows 5 rests against the end bottom 4. Capillary tube 6 is connected to end bottom 4. The capillary tube 6 can be used for a heat transfer from an evaporator (not shown) or cold air flow to the thermostat device 1.

20

An actuator arrangement 7 is located in housing 2 and is moveable in a direction parallel to the longitudinal axis 3. The actuator arrangement 7 comprises a first element 8 and a second element 9. First element 8 comprises a first part 10 and a second part 11. First part 10 comprises a number of studs 12 which are guided through the second element 9. The second part 11 of the first element 8 rests on top of the studs 12. It can be connected to the studs 12. However, in most cases it is sufficient when the second part 11 is fixed relative to the studs 12 against a movement in a radial direction related to the longitudinal axis 3.

30

In the present case there are three studs 12 (cf. Fig. 5). These three studs 12 are uniformly distributed in circumferential direction, i.e. they have an angular distance of 120° relative to each other.

- 5 The second element 9 forms a bearing arrangement for a linear movement of the first element 8 relative to the second element 9 in a direction parallel to the longitudinal axis 3.

A first spring 13 is located between the first pretension screw 14 and the
10 second part 11 of the first element 8. The first pretension screw 14 is screwed into second element 9 in this way the second part 11 of first element 8 is pressed against the second element 9.

A force created by bellows 5 acts in opposite direction on the first part 10 of
15 the first element 8, so that the first part 10 and the second part 11 are held together by forces generated by bellows 5 and first spring 13. When bellows 5 expands due to an increase of temperature, the first element 8 and the second element 9 are moved together, i.e. they are moved like a one piece part. This movement takes place against a force of a second spring 15.

20 Second spring 15 rests against a washer 16. The position of washer 16 is determined by a second pretension screw 17. Second pretension screw 17 is connected to a cam element 18. Cam element 18 is shown in a perspective view in Fig. 4. Cam element 18 rests against an end top 19 and is rotatable in housing 2.

25

The second pretension screw 17 can be screwed into or otherwise fixed to cam element 18.

As can be seen in Fig. 4, cam element 18 comprises three identical working
30 areas, each area having three regions of different heights or thicknesses. A first region 20 in which the cam element 18 has the smallest thickness

defines a position "cold", a second region 21 having a slightly larger thickness defines a position "warm" and a region 22 having the largest thickness defines a position "stop". The cam element 18 can be rotated when a torque is applied to a control rod 23.

5

The end top 19 comprises a number of protrusions 24 corresponding to the number of working areas so that the cam element 18 rests with one of the regions against the end top 19. Depending on the angular position of the cam element 18 the first spring 15 is more or less compressed, i.e. pretensioned.

10 The total working range of the cam element 18 is the whole area between the positions cold and warm.

Basically the regions 20-22 define the pretension of the second spring 15 is adjusted to a position "cold" and a position "warm". It is furthermore possible to include a position "stop". However, the "stop"-position can be realized by other means as well.

15

A fine adjustment of the pretension of the second spring 15 can be made with help of the second pretension screw 17, when it is screwed more or less into the cam element 18.

20

Housing 2 comprises a number of grooves 25, in the present case it comprises three grooves 25. As can be seen in Fig. 5, the grooves 25 are arc-shaped.

25

The second element 9 comprises a corresponding number of gliding elements 26 which are basically of V-shape and has preferably a rounded tip 27. The cooperation of the gliding element 26 and the grooves 25 allow for a low friction movement of the second element 9 in housing 2 and at the same time prevent rotation of second element 9 in housing 2.

30

Grooves 25 have a limited length in a direction parallel to the longitudinal axis 3. At an end opposite to end bottom 4 they form a stop 27 which limits the movement of the second element 9 away from the end bottom 4.

5 First element 8 comprises an actuation arm 28 which extends out of housing 2 radially with respect to longitudinal axis 3. The actuation arm 28 is used to operate a switch (not shown) which makes or breaks an electric connection between a power source and a motor of a compressor or the like.

10 The operation of the thermostat device 1 can be described as follows:

When the volume of bellows 5 increases due to rising temperature, the first element 8 and the second element 9 are together moved away from end bottom 4 until second element 9 comes to rest against stop 27. During this
15 movement second spring 15 is compressed and the first spring 13 holds second part 11 of the first element 8 in contact with second element 9.

Fig. 2 shows the situation in which second element 9 has reached the end position, i.e. stop 27, and cannot be moved further. In this situation the
20 second element 9 and the second spring 15 are blocked since the second spring 15 is placed on the second element 9.

Further increase of the force generated by bellows 5 causes first element 8 to move relative to second element 9 against the force of first spring 13. During
25 this movement first element 8 is guided by second element 9. Finally the actuation arm 28 of first element 8 reaches a fixed cut-in point of a contact system (not shown). Contact system cuts-in and starts the refrigeration circuit of the appliance.

30 After start of the appliance refrigeration circuit the evaporator cools down and so does the thermostat sensor. In other words, pressure inside the bellows 5

decreases and so decreases the force generated by bellows 5. First spring 13 forces first element 8 back towards second element 9 until second part 11 of first element 8 touches second element 9. The movement of the first element 8 in the bearings of the second element 9 ends and the first spring 5 13 stops working. When the decrease of the bellows produced force continues, second element 9 detaches from stop 27 and the first element 8 and the second element 9 move as a common part. In this moment the second spring 15 starts to work again and forces the second element 9 that glides in the grooves 25 of housing 2 into a cut-out position.

10

It should be mentioned, that washer 16 is guided in similar grooves 29 of housing 2. However, grooves 29 are separated from grooves 25. As can be seen in Fig. 3, washer 16 comprises fingers 30 which hold second spring 15 in a predetermined radial position relative to longitudinal axis 3. These fingers 15 30 are located radially outside of second spring 15. Second element 9 comprises protrusions 31 radially inside second spring 15 and defining a radial position of second spring 15 relative to second element 9.

As can be seen in Fig. 3, first part 10 of first element 8 comprises a stop 20 20 which comes to contact second element 9 when the first element 8 is in the end position.

The basic principle of the thermostat device is the linear movement of the first element 8 and the second element 9. This design allows to use a 25 compression coil spring and their concentric arrangement. This saves space in mechanical part of the thermostat device and creates a potential for mechanical parts dimensional optimization. Thermostat function is generally given by the set-up of the first element 8 and the second element 9. The concentric arrangement of the springs 13, 15 in case of constant cut-in and 30 large differential thermostats leads to a design of tubular (or triangular or

polygonal) housing and to symmetric design most parts of the mechanical system.

5 Thermostat function is given by the set-up of first element 8 and second element 9. Set-up of these elements 8, 9 together with second spring 15 defines the thermostat function. The above description deals with a thermostat device 1 with constant cut-in. Other thermostat types can use the same principle just by modification of the element mentioned.

Claims

1. Thermostat device (1) comprising a housing (2) having a longitudinal axis (3), a bellows (5) arranged in said housing (2), an actuator arrangement (7) movable in a direction parallel to said longitudinal axis (3), loaded by a force produced by said bellows (5) in a first
5 direction and by a force of a spring arrangement (13, 15) in a second direction opposite said first direction and comprising a first element (8) and a second element (9), characterized in that said spring arrangement (13, 15) comprises a first spring (13) holding said first element (8) and said second element (9) together to move said first
10 element (8) and said second element (9) like a one piece part until said second element (9) comes to rest against a stop (27).
2. Thermostat device according to claim 1, characterized in that said first spring (13) is pretensioned between said first element (8) and
15 said second element (9) by means of a pretension element fixed to said second element (9).
3. Thermostat device according to claim 2, characterized in that said pretension element is in form of a first pretension screw (14) which is
20 screwed into said second element (9).
4. Thermostat device according to any of claims 1 to 3, characterized in that said first element (8) comprises a first part (10) on a first side of
25 said second element (9) and a second part (11) on a second side of said second element (9) opposite said first side, one of said first part (10) and said second part (11) passing through said second element (9), wherein said first part (10) and said second part (11) are held together by forces generated by said bellows (5) and said first spring (13).

5. Thermostat device according to claim 4, characterized in that said second element (9) forms a bearing arrangement for a linear movement of said first element (8) relative to said second element (9) in a direction parallel to said longitudinal axis (3).
6. Thermostat device according to any of claims 1 to 5, characterized in that said first element (8) comprises an actuator arm (28) extending out of said housing (2) radially with respect to said longitudinal axis (3).
7. Thermostat device according to any of claims 1 to 6, characterized in that said spring arrangement (13, 15) comprises a second spring (15) acting on said second element (9).
8. Thermostat device according to claim 7, characterized in that said first spring and said second spring (15) are arranged concentrically.
9. Thermostat device according to claim 7 or 8, characterized in that a pretension of said second spring (15) is adjustable by a cam element (18) which is mounted between said second spring (15) and an end top (19) of said housing (2).
10. Thermostat device according to claim 9, characterized in that said cam element (18) is mounted rotatably in said housing (2).
11. Thermostat device according to claim 9 or 10, characterized in that said cam element (18) comprises at least one working area, each working area comprising at least two different regions (20, 21, 22), said regions (20, 21, 22) differing in a pretension characteristic.

12. Thermostat device according to any of claims 9 to 11, characterized in that said cam element (18) is in threaded connection with a second pretension screw (17), said second pretension screw (17) being
5 positioned between said cam element (18) and said second spring (15).
13. Thermostat device according to any of claims 1 to 12, characterized in that said housing (2) comprises a predetermined number of
10 grooves (25) running parallel to said longitudinal axis (3), wherein said second element (9) comprises gliding elements (26) which are arranged in said grooves (25).
14. Thermostat device according to claim 13, characterized in that said
15 housing (2) comprises three grooves (25) spaced in circumferential direction by 120°.
15. Thermostat device according to claim 13 or 14, characterized in that
20 said gliding elements (26) are of V-shape, in particular with rounded tips (27).

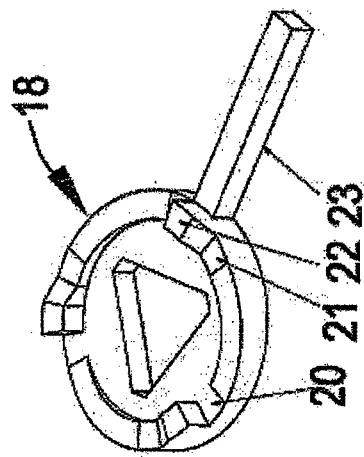

Fig. 4

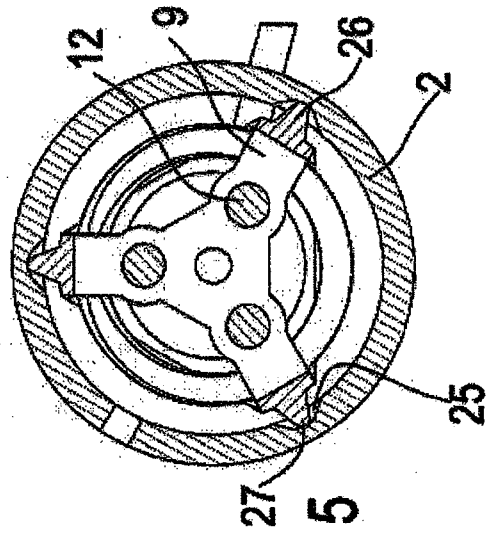

Fig. 5

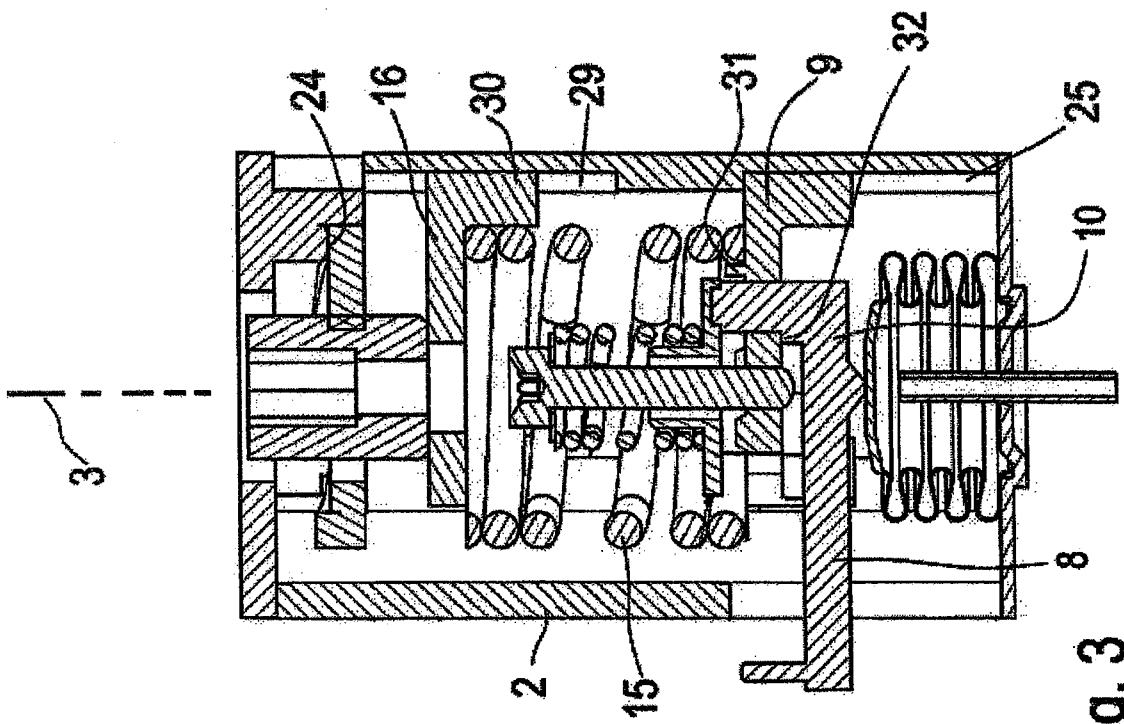

Fig. 3

INTERNATIONAL SEARCH REPORT

International application No
PCT/EP2017/058867

A. CLASSIFICATION OF SUBJECT MATTER
INV. G05D23/12
ADD.

According to International Patent Classification (IPC) or to both national classification and IPC

B. FIELDS SEARCHED
Minimum documentation searched (classification system followed by classification symbols)
G05D F24D

Documentation searched other than minimum documentation to the extent that such documents are included in the fields searched

Electronic data base consulted during the international search (name of data base and, where practicable, search terms used)
EPO-Internal, WPI Data

C. DOCUMENTS CONSIDERED TO BE RELEVANT

Category*	Citation of document, with indication, where appropriate, of the relevant passages	Relevant to claim No.
X	US 3 108 747 A (DANDANELL NIELSEN HOLGER) 29 October 1963 (1963-10-29) figure 1 -----	1-15
X A	EP 2 857 920 A1 (GIACOMINI SPA [IT]) 8 April 2015 (2015-04-08) paragraphs [0042] - [0133]; figures 1,2 -----	1,4,5,7, 8 2,3,6
X	EP 0 903 525 A2 (MACRIFIN SPA [IT]) 24 March 1999 (1999-03-24) figure 1 -----	1

Further documents are listed in the continuation of Box C.

See patent family annex.

* Special categories of cited documents :

<p>"A" document defining the general state of the art which is not considered to be of particular relevance</p> <p>"E" earlier application or patent but published on or after the international filing date</p> <p>"L" document which may throw doubts on priority claim(s) or which is cited to establish the publication date of another citation or other special reason (as specified)</p> <p>"O" document referring to an oral disclosure, use, exhibition or other means</p> <p>"P" document published prior to the international filing date but later than the priority date claimed</p>	<p>"T" later document published after the international filing date or priority date and not in conflict with the application but cited to understand the principle or theory underlying the invention</p> <p>"X" document of particular relevance; the claimed invention cannot be considered novel or cannot be considered to involve an inventive step when the document is taken alone</p> <p>"Y" document of particular relevance; the claimed invention cannot be considered to involve an inventive step when the document is combined with one or more other such documents, such combination being obvious to a person skilled in the art</p> <p>"&" document member of the same patent family</p>
---	---

Date of the actual completion of the international search 7 July 2017	Date of mailing of the international search report 18/07/2017
--	--

Name and mailing address of the ISA/ European Patent Office, P.B. 5818 Patentlaan 2 NL - 2280 HV Rijswijk Tel. (+31-70) 340-2040, Fax: (+31-70) 340-3016	Authorized officer Arenz, Rainer
--	---

INTERNATIONAL SEARCH REPORT

Information on patent family members

International application No

PCT/EP2017/058867

Patent document cited in search report	Publication date	Patent family member(s)	Publication date
US 3108747	A	29-10-1963	NONE

EP 2857920	A1	08-04-2015	CN 104514913 A 15-04-2015
			EP 2857920 A1 08-04-2015

EP 0903525	A2	24-03-1999	AT 227402 T 15-11-2002
			DE 69809165 D1 12-12-2002
			EP 0903525 A2 24-03-1999
			IT MI972110 A1 17-03-1999
			PT 903525 E 31-03-2003
