

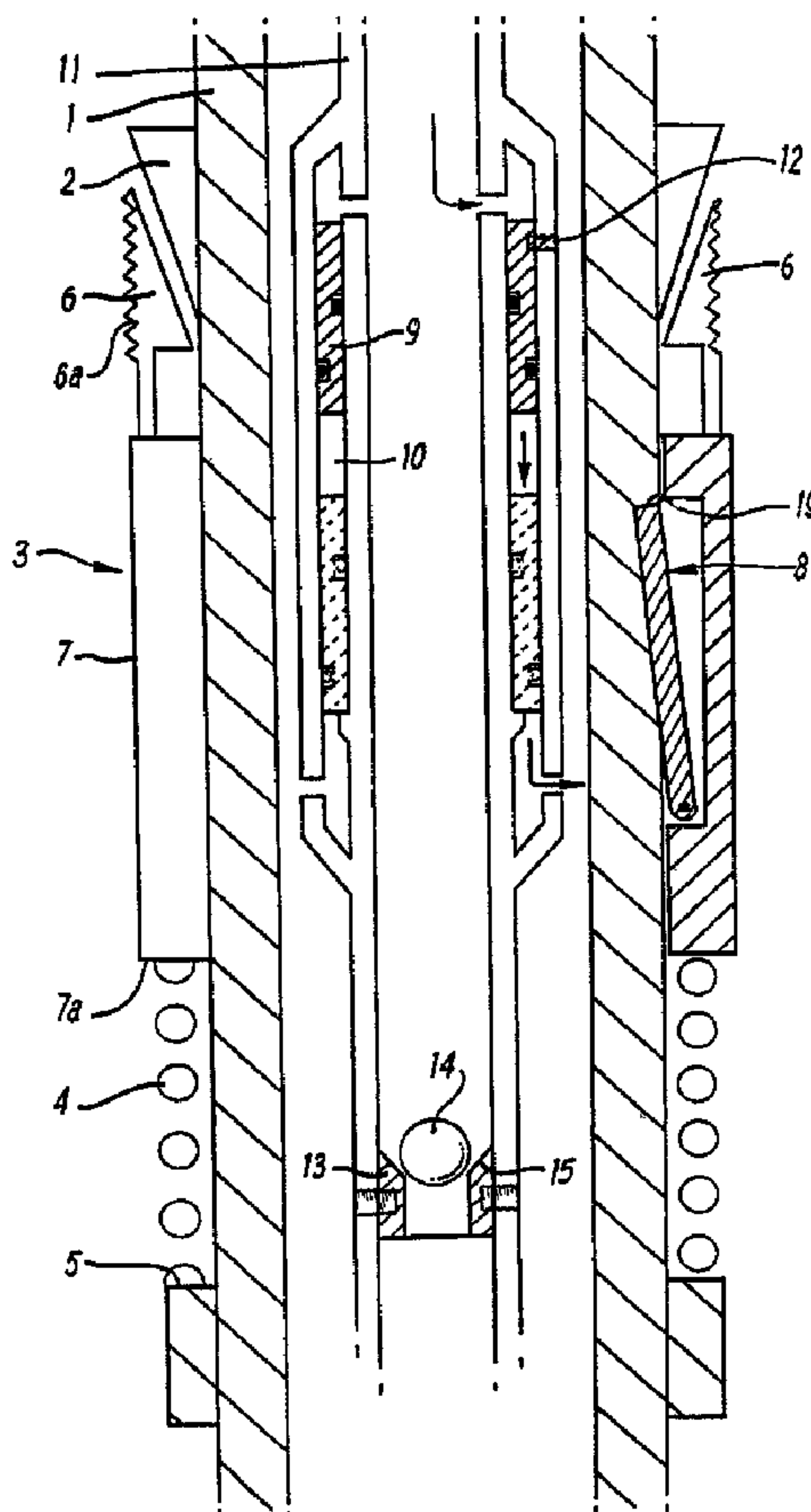

(86) Date de dépôt PCT/PCT Filing Date: 1996/05/30  
 (87) Date publication PCT/PCT Publication Date: 1996/12/05  
 (45) Date de délivrance/Issue Date: 2007/07/10  
 (85) Entrée phase nationale/National Entry: 1997/10/27  
 (86) N° demande PCT/PCT Application No.: GB 1996/001275  
 (87) N° publication PCT/PCT Publication No.: 1996/038649  
 (30) Priorités/Priorities: 1995/05/31 (GB9510923.7);  
 1995/07/27 (GB9515419.1)

(51) Cl.Int./Int.Cl. *E21B 23/00* (2006.01),  
*E21B 23/04* (2006.01), *E21B 33/129* (2006.01),  
*E21B 33/1295* (2006.01), *E21B 43/10* (2006.01)  
 (72) Inventeur/Inventor:  
 TELFER, GEORGE, GB  
 (73) Propriétaire/Owner:  
 WEATHERFORD/LAMB, INC., US  
 (74) Agent: MCFADDEN, FINCHAM

(54) Titre : SYSTEME D'ACTIONNEMENT POUR APPAREIL DE FORAGE  
 (54) Title: ACTIVATING MEANS FOR DRILLING APPARATUS



(57) **Abrégé/Abstract:**

An activating means for activating a down-hole tool incorporates a magnet, which may include an attracting magnet (12) and a repelling magnet (13), and which may move under hydraulic pressure from an active position at which it causes a trigger, valve (8) or spring to be energised to a non active position at which the tool is not activated, the activating means thereby utilising hydraulic pressure without requiring hydraulic ports in the liner or mandrel.

**PCT**WORLD INTELLECTUAL PROPERTY ORGANIZATION  
International Bureau

## INTERNATIONAL APPLICATION PUBLISHED UNDER THE PATENT COOPERATION TREATY (PCT)

(51) International Patent Classification <sup>6</sup> : <b>E21B 23/00, 43/10, 33/1295, 23/04, 33/129</b>	<b>A3</b>	(11) International Publication Number: <b>WO 96/38649</b> (43) International Publication Date: 5 December 1996 (05.12.96)
<p>(21) International Application Number: PCT/GB96/01275</p> <p>(22) International Filing Date: 30 May 1996 (30.05.96)</p> <p>(30) Priority Data: 9510923.7 31 May 1995 (31.05.95) GB 9515419.1 27 July 1995 (27.07.95) GB</p> <p>(71) Applicant (for all designated States except US): WEATHER-FORD/LAMB. INC. [US/US]; Prentice Hall Corporation System, Inc., Suite L-100, 32 Lockerman Square, Dover, DE 19901 (US).</p> <p>(72) Inventor; and (75) Inventor/Applicant (for US only): TELFER, George [GB/GB]; International Base, Greenwell Road, East Tullis, Aderdeen AB1 4AX (GB).</p> <p>(74) Agent: LUCAS, Brian, Ronald; Lucas &amp; Co., 135 Westhall Road, Warlingham, Surrey CR6 9HJ (GB).</p>	<p>(81) Designated States: AU, CA, CN, JP, NO, US, European patent (AT, BE, CH, DE, DK, ES, FI, FR, GB, GR, IE, IT, LU, MC, NL, PT, SE).</p> <p><b>Published</b> <i>With international search report. Before the expiration of the time limit for amending the claims and to be republished in the event of the receipt of amendments.</i></p> <p>(88) Date of publication of the international search report: 20 February 1997 (20.02.97)</p>	

(54) Title: ACTIVATING MEANS FOR A DOWN-HOLE TOOL

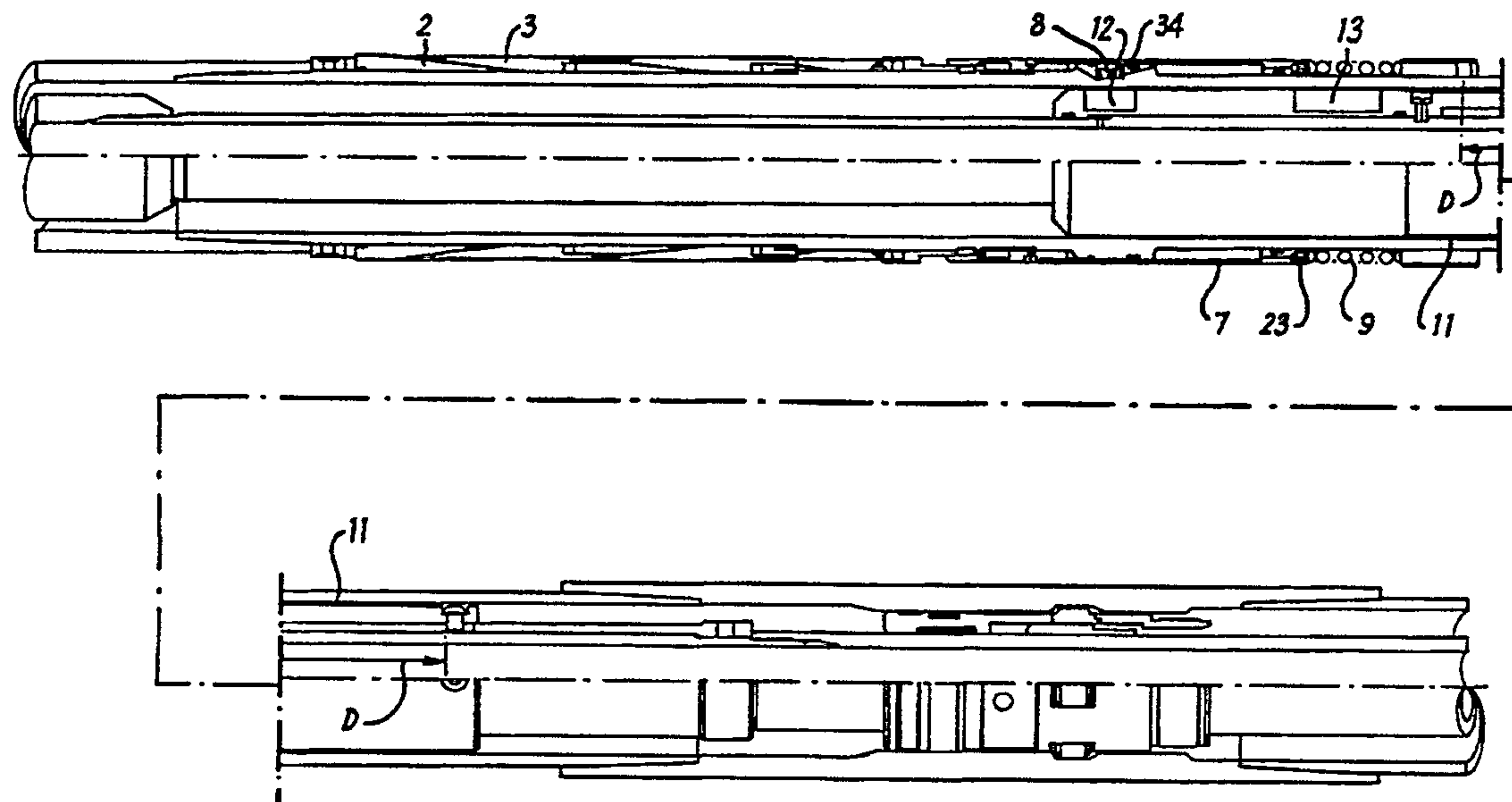

## (57) Abstract

An activating means for activating a down-hole tool incorporates a magnet, which may include an attracting magnet (12) and a repelling magnet (13), and which may move under hydraulic pressure from an active position at which it causes a trigger, valve (8) or spring to be energised to a non active position at which the tool is not activated, the activating means thereby utilising hydraulic pressure without requiring hydraulic ports in the liner or mandrel.

ACTIVATING MEANS FOR SETTING A LINER HANGER  
OR A PACKER IN A CASING

This invention relates to an activating means for setting a liner hanger or a packer in a casing.

5           Liner hangers are used to secure a liner to a casing in a subterranean gas or oil well. In the past, they have been set both mechanically or hydraulically. Traditionally, mechanical liner hangers have comprised leaf springs and a "J" slot mechanism. The leaf springs  
10           have been required to be fragile, due to restricted space between the exterior of the liner hanger and the interior of the casing, and thus these have been easily damaged. Also, the "J" slot mechanism is frequently difficult to activate in view of drag forces required to  
15           be overcome.

          Hydraulically activated liner hanger units have therefore become more common. With these, one or more rows of slips are urged by pressurised hydraulic fluid into engagement with respective cones or cone segments  
20           positioned on the liner or on a sleeve surrounding the liner. The hydraulic fluid is supplied through an appropriate channel inside the liner and, at some point, is caused to pass through a small bore or port in the liner to a hydraulic cylinder or the like on the outside  
25           of the liner. The provision of this bore, however, although necessary for the supply of fluid, often is disadvantageous in that it may become clogged, or may leak undesirably.

          Hydraulic ports of a similar nature, and associated  
30           with similar problems, have been required for other apparatus which are activated hydraulically.

          An object of the present invention is to provide a magnet activating means for activating a liner hanger, packer or other down-hole equipment without the need for  
35           hydraulic ports, notwithstanding the use of hydraulic

- 2 -

fluid.

According to the present invention there is provided an activating means for setting a liner hanger or a packer in a casing, the activating means comprising a spring which biases a slip towards an operative position in which, in use, it engages said casing, an obstruction means movable between an obstructing position where movement of the slip is prevented and a non-obstructing position where movement of the slip into said operative position is enabled, wherein movement of the obstructing means is caused by a magnet, the magnet itself being operably movable between a remote location and an active location at which magnetic force derived from the magnet causes movement of the obstructing means to the non-obstructing position, in turn allowing the spring, in use, to move the slip into a casing engaging position.

In accordance with another embodiment of the present invention, there is provided an activation means for activating a down-hole tool located on or near the external face of a liner or mandrel, the activation means comprising a magnet located internally of the liner or mandrel, a compressed spring and a hydraulic cylinder located externally of the liner or mandrel, the cylinder including a valve means to facilitate the controllable release of hydraulic fluid from the cylinder when the valve means is opened, the valve means being biased in a closed position but caused to open when acted upon by a magnetic force derived from the magnet, wherein release of hydraulic fluid from the cylinder causes the spring to move the cylinder to effect activation of the tool, wherein the magnet comprises a spaced apart attracting magnet and repelling magnet.

Another embodiment of the present invention provides a liner hanging apparatus for hanging a liner in a wellbore comprising one or more cone segments mounted on the liner and

- 2a -

one or more respective slips mounted on the liner  
and adapted upon slidable upward movement to engage with the  
cone segments to cause outward expansion of the slips and  
5 setting of the liner, wherein the upward movement of the  
slips is encouraged by a compressive spring acting between  
the liner below the slips and the slips, wherein the upward  
movement of the slips is physically prevented by a trigger  
member when the trigger member is in a first position but  
10 enabled when the trigger member is in a second position, the  
trigger member being biased toward the first position while  
movable to the second position when acted upon by a magnetic  
force derived from a magnet located inside the liner, wherein  
the trigger member comprises a pin hingeably attached to a  
15 the slip.

20

25

30

Embodiments of the invention will now be described by way of example only with reference to the accompanying figures, in which:

Figure 1 is a sectional elevation of a liner hanger apparatus incorporating the invention;

Figure 2 is a further elevation of liner hanger apparatus incorporating the invention in an alternative and preferred form; and

Figure 3 is a further elevation of down-hole packer incorporating an embodiment of the invention.

In Figure 1 a liner 1 is located in a wellbore. The liner 1 supports a plurality of cone segments 2, which in this embodiment are integrally attached to the exterior wall of the liner 1. It is not essential to the invention however, that this be the case, and the inclusion of a rotatable sleeve supporting the segments 2 may be incorporated.

Slips 3, having a tapered head portion 6 and a sleeve portion 7 are provided around the liner 1, the slips 3 being vertically slidable such that their tapered portion 6 may engage with the cone segments 2. This engagement causes the slips 6 to be pushed outwardly until the toothed face 6a of the slips 3 grips securely on the well casing (not shown).

A spring 4 is located between a shoulder 5 integral with the liner 1 and the lower face 7a of the sleeve portion 7 on the slips 3. The spring 4 is loaded with a compressive force; thereby encouraging the slips 3 upwardly relative to the liner 1 and the cone segments 2. However, the slips 3 are impeded from travelling upwardly and setting the tool until such time as this is desired by a trigger member 8 located within and pivotally attached to the sleeve portion 7 which is biased to a first position where at it is illustrated in the figure. When at the first position the trigger member 8

5 nests in a receptive cut out portion in the wall of the  
liner 1 and upward movement of the sleeve is prohibited  
by fouling of the trigger 8 on the shoulder 19 of the  
cut out portion of the liner 1.

5 A magnet 9 slidably located in a channel 10 in the  
running tool 11 is provided to move the trigger member 8  
into a second position when desired. The magnet, which  
in the embodiment shown is a repelling magnet in the  
form of an annular piston, is held at the top of the  
10 channel 10 by a shear pin 12 until the liner is in the  
desired setting position. While the magnet 9 is at the  
top of the channel 10 it does not significantly act upon  
the trigger member 8, and the trigger 8 therefore re-  
mains in the first position preventing upward movement  
15 of the slips 3.

Then, when the setting position is reached, fluid  
travelling down the internal bore within the running  
tool 11 is dammed by a closure member 13, which in this  
embodiment comprises a ball 14 resting on a seat 15.  
20 The fluid path is thereby diverted into the channel 10  
and causes the pin 12 to shear and the magnet 9 to slide  
down the channel 10 into an active position; that being  
a position where it actively repels the trigger member 8  
causing the trigger member 8 to pivot to its second  
25 position clear of the liner wall. The compressive force  
of the spring 4 then pushes the slip 3 upwardly and into  
engagement with the cone segments 2.

An alternative embodiment is illustrated in Figure  
2. Here, a spring 9 is energised in compression and  
30 acts upon the hydraulic piston and cylinder 7. The  
cylinder 7 is provided with hydraulic fluid through an  
inlet which is thereafter plugged by the plug 23. The  
fluid, under pressure, resists movement of the cylinder  
7 notwithstanding the force applied to the cylinder 7 by  
35 the spring 9.

A magnet housing 11 is located internally of the liner and carries an attracting magnet 12 and a repelling magnet 13. The magnet housing 11 is slidable within the liner by the distance "D". When the housing is located as shown in Figure 2, the attracting magnet 12 attracts the magnetic poppet 8 housed in the O-ring 34.

The poppet 8 acts as a valve means when so attracted preventing the escape of hydraulic fluid from the cylinder 7. However, upon the movement of the magnet housing 11 through the distance D, the repelling magnet 13 moves to the position previously occupied by the attracting magnet 12 (which itself moves away) which, in turn, repels the poppet 8 outward against the frictional resistance of the O-ring 34, thereby opening the valve means and allowing the escape of hydraulic fluid. The spring force then succeeds in moving the cylinder up the liner, acting on the liner hanger arrangement with the effect of causing the slips 3 to slide up the cones 2, setting the liner.

The embodiment illustrated in Figure 3 represents how the invention may be applied with similar effect in relation to a packer. In this case the liner hanger is replaced by a packer, and alternative spring and/or magnet characteristics may be employed.

The invention thus negates the need for small bores through the liner to facilitate the supply of hydraulic fluid, while still not requiring the demanding physical requirements associated with purely mechanical liner hangers and other downhole tools. It also facilitates the use of relatively small outside diameters and allows for enhanced bypass areas, with lesser flow impedance.

Further modifications may be incorporated without departing from the scope of the invention herein intended.

- 6 -

THE EMBODIMENTS OF THE INVENTION IN WHICH AN EXCLUSIVE PROPERTY OR PRIVILEGE IS CLAIMED ARE DEFINED AS FOLLOWS:

1. An activating means for setting a liner hanger or a packer in a casing, the activating means comprising a spring which biases a slip towards an operative position in which, in use, it engages said casing, an obstruction means movable between an obstructing position where movement of the slip is prevented and a non-obstructing position where movement of the slip into said operative position is enabled, wherein movement of the obstructing means is caused by a magnet, the magnet itself being operably movable between a remote location and an active location at which magnetic force derived from the magnet causes movement of the obstructing means to the non-obstructing position, in turn allowing the spring, in use, to move the slip into a casing engaging position.

2. The activating means according to claim 1, wherein the magnet is movable under hydraulic pressure.

3. The activating means according to claim 1 or 2, wherein the obstruction means comprises a hydraulic piston and cylinder.

4. A liner hanger including an activating means as claimed in claim 3, wherein said liner hanger comprises a liner and said hydraulic piston and cylinder is located externally of said liner, the piston and cylinder including a valve means to facilitate controllable release of hydraulic fluid from the cylinder of said piston and cylinder when said valve means is opened, the valve means being biased towards a closed position but caused to open when acted upon by the magnetic force derived from the magnet to release hydraulic fluid from said cylinder and thereby allow the spring to move the cylinder and effect movement of said slip into its casing engaging position.

- 7 -

5. A packer including an activating means as claimed in claim 3, wherein said packer comprises a mandrel and said hydraulic piston and cylinder is located externally of said mandrel, the piston and cylinder including a valve means to facilitate controllable release of hydraulic fluid from the cylinder of said piston and cylinder when said valve means is opened, the valve means being biased towards a closed position but caused to open when acted upon by the magnetic force derived from the magnet to release hydraulic fluid from the cylinder and thereby allow the spring to move the cylinder and effect movement of the slip into its casing engaging position.

6. The liner hanger as claimed in claim 4 or the packer as claimed in claim 5, wherein the magnet comprises an attracting magnet and a repelling magnet which are spaced apart.

7. The liner hanger or the packer as claimed in claim 6, wherein the attracting magnet may be used to bias the valve means towards a closed position and the attracting magnet may be used to open the valve means.

8. The liner hanger or the packer as claimed in claim 6 or 7, wherein the attracting magnet is rigidly linked to the repelling magnet such that movement of the repelling magnet into close proximity to the valve means causes a corresponding movement of the attracting magnet away from the valve means.

9. The liner hanger as claimed in claim 4, 6, 7 or 8, which comprises one or more cone segments mounted on said liner and one or more respective ones of said slip mounted on said liner and adapted, in use, upon slidable upward movement to engage with the cone segments to cause outward expansion of the slips and setting of the liner, wherein the upward movement of the slips is urged by said spring acting between

the liner below the slips and the slips, wherein the upward movement of the slips is physically prevented by said obstruction means.

10. The liner hanger as claimed in claim 9, wherein said obstruction means comprises a pin hingeably attached to a said slip.

11. The liner hanger as claimed in claim 10, wherein, when the pin is in the obstructing position, it is caused to foul or nest on or in a respective shoulder on the external side of the liner.

12. The liner hanger as claimed in claim 9, 10 or 11, wherein the magnet is a cylindrical repelling magnet located in an annular channel in a running tool positioned internally of the liner.

13. The liner hanger as claimed in claim 12, wherein the magnet is slidable within the channel under pressurised fluid from a non-active first position to an active second position at which the magnet repels the pin outward to such an extent that the pin does not foul on the liner and the slips are free to fluids vertically upward.

14. The liner hanger as claimed in claim 13, wherein the magnet is held in the non-active position until the liner is at the setting depth by a shear pin connecting the magnet with a wall of the annular channel.

15. The liner hanger as claimed in claim 13 or 14, wherein a closure member is provided to close a flow path of the fluid within the running tool and, in use, divert the fluid into the channel when it is sought to move the magnet to the active position.

16. The liner hanger as claimed in claim 15, wherein the closure member is a ball which can be dropped onto a ball seat held in the running tool.

- 9 -

17. An activation means for activating a down-hole tool located on or near the external face of a liner or mandrel, the activation means comprising a magnet located internally of the liner or mandrel, a compressed spring and a hydraulic cylinder located externally of the liner or mandrel, the cylinder including a valve means to facilitate the controllable release of hydraulic fluid from the cylinder when the valve means is opened, the valve means being biased in a closed position but caused to open when acted upon by a magnetic force derived from the magnet, wherein release of hydraulic fluid from the cylinder causes the spring to move the cylinder to effect activation of the tool, wherein the magnet comprises a spaced apart attracting magnet and repelling magnet.

18. The activating means according to claim 17, wherein the attracting magnet may be used to bias the valve means in a closed position and the attracting magnet may be used to open the valve means.

19. The activating means according to claim 17, wherein the attracting magnet is rigidly linked to the repelling magnet such that movement of the repelling magnet into close proximity to the valve means causes a corresponding movement of the attracting magnet away from the valve means.

20. The activating means according to any one of claims 17 to 19, wherein movement of the magnet may be effected hydraulically.

21. Liner hanging apparatus for hanging a liner in a wellbore comprising one or more cone segments mounted on the liner and one or more respective slips mounted on the liner and adapted upon slidable upward movement to engage with the cone segments to cause outward expansion of the slips and setting of the liner, wherein the upward movement of the

- 10 -

slips is encouraged by a compressive spring acting between the liner below the slips and the slips, wherein the upward movement of the slips is physically prevented by a trigger member when the trigger member is in a first position but enabled when the trigger member is in a second position, the trigger member being biased toward the first position while movable to the second position when acted upon by a magnetic force derived from a magnet located inside the liner, wherein the trigger member comprises a pin hingeably attached to a said slip.

22. The liner hanging apparatus as claimed in claim 21, wherein the trigger member is in the first position, it is caused to foul or nest on or in a respective shoulder on the external side of the liner.

23. The liner hanging apparatus as claimed in claim 21, wherein the magnet is a cylindrical repelling magnet located in an annular channel in a running tool positioned internally of the liner.

24. The liner hanging apparatus as claimed in claim 21, wherein the magnet is slidable within the channel under pressurised fluid from a non active first position to an active second position at which the magnet repels the trigger member outward to such extent that the trigger does not foul on the liner and the slips are free to slide vertically upward.

25. The liner hanging apparatus as claimed in claim 21, wherein the magnet is held in the non-active position until the liner is at the setting depth by a shear pin connecting the magnet with the annular channel wall.

26. The liner hanging apparatus as claimed in claim 21, wherein a closure member is provided to close the flow path of the fluid within the running tool and to divert the fluid into the channel when it is sought to move the magnet to the

- 11 -

active position.

27. The liner hanging apparatus as claimed in claim 26, wherein the closure member is a ball dropped on to a ball seat held in the running tool.

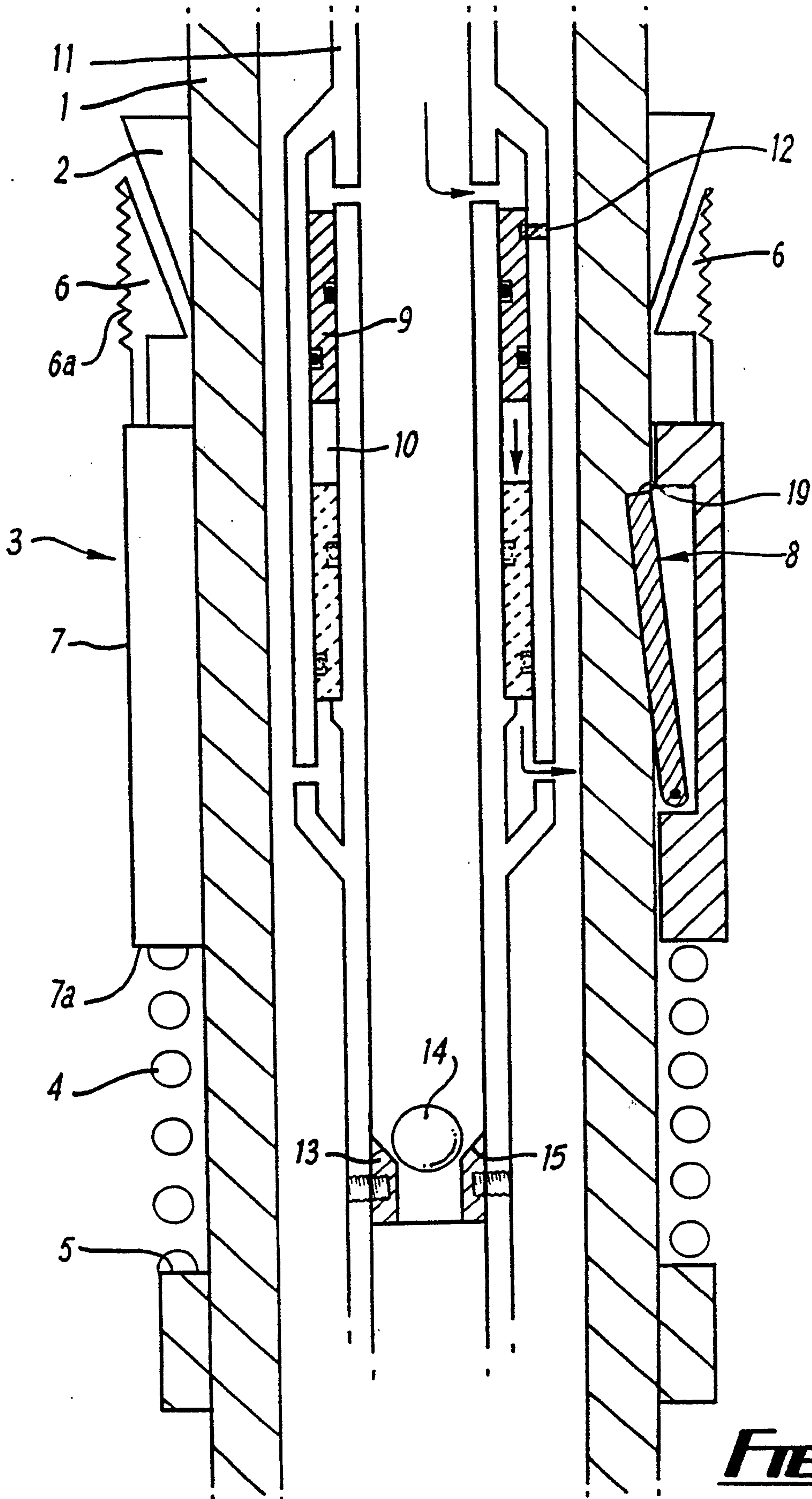

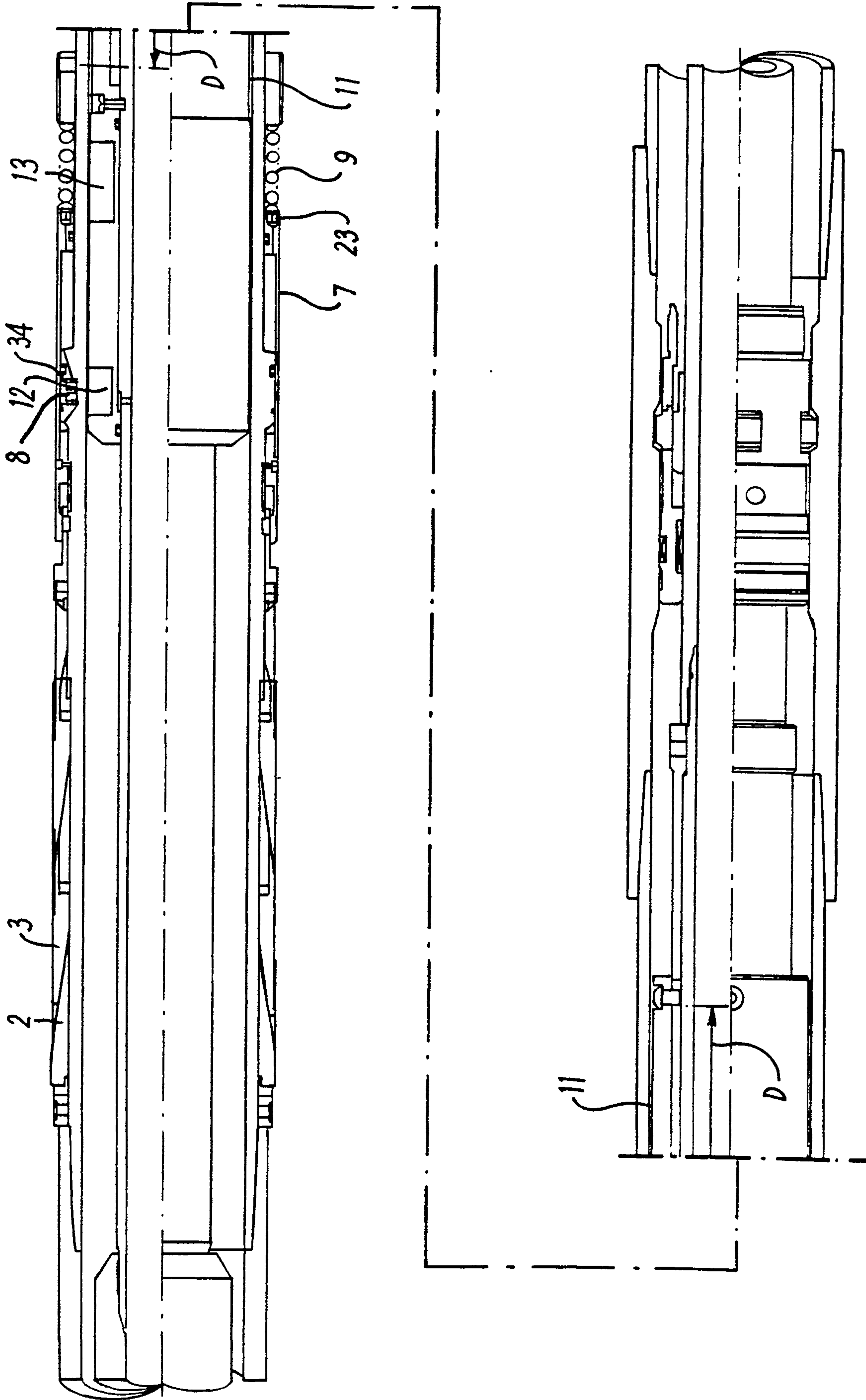

**FIG. 2**

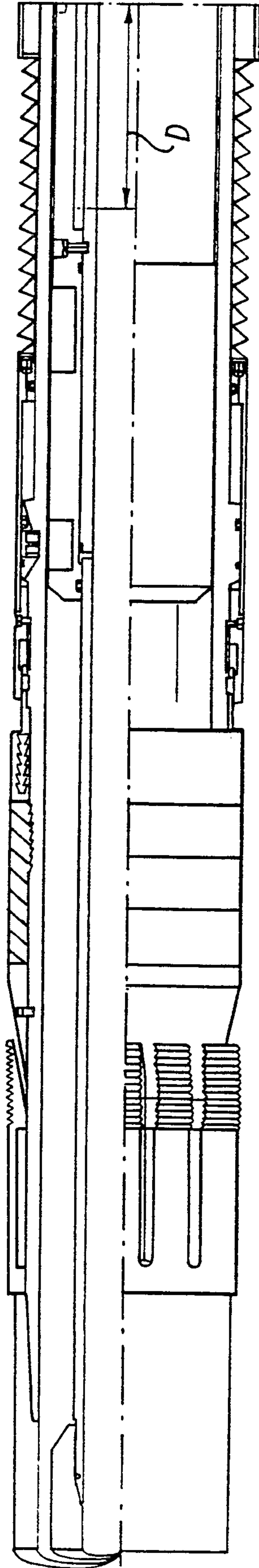

**FIG. 3**

