

July 1, 1958

W. F. STREMKE ET AL  
WRAPPING METHOD AND APPARATUS

2,840,962

Filed June 1, 1954

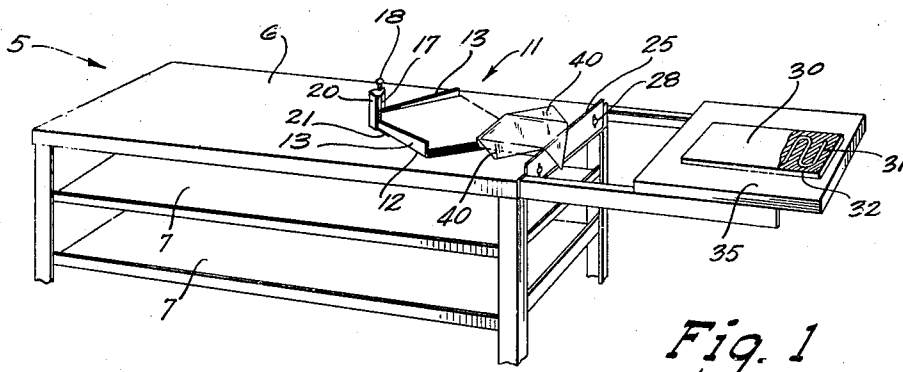

Fig. 1

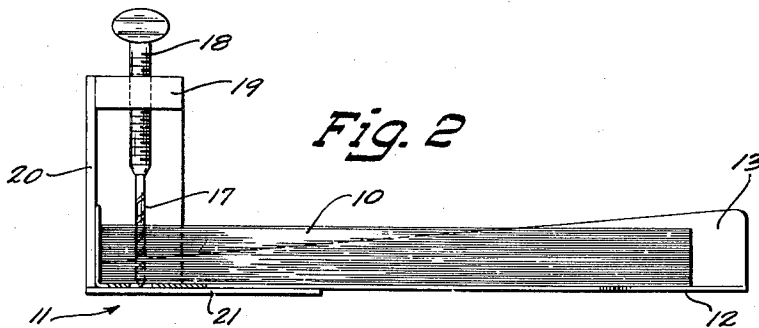

Fig. 2

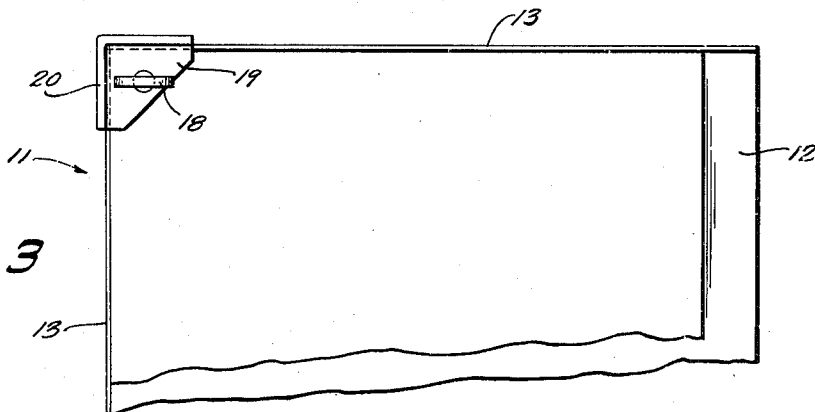

Fig. 3

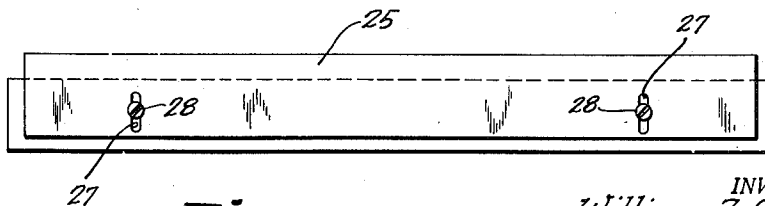

Fig. 4

INVENTORS.  
William F. Stremke,  
William F. Stremke Jr., +  
Roman R. Pazderski.  
By Cyril M. Hajewski  
Attorney

1

2,840,962

**WRAPPING METHOD AND APPARATUS**

**William F. Stremke, William F. Stremke, Jr., and Roman R. Pazderski, Milwaukee, Wis.**

Application June 1, 1954, Serial No. 433,664

9 Claims. (Cl. 53—31)

This invention relates generally to a wrapping apparatus, and more particularly to an improved apparatus especially adapted to facilitate the manual wrapping of food.

The acceptance of the self-service food market as an efficient method of retailing has given rise to the problem of packaging meat, produce, and other bulk foods in sealed, transparent packages containing varying quantities to accommodate the desires of the customers. The wrapping material must be transparent to enable the customer to view the contents, and the package must be sealed for sanitary reasons, as well as to prevent its being tampered with. Each package is marked to identify it as to its contents, quantity, and price for the convenience of the customer who may select the desired package and take it to a designated place to pay for it. This method of retailing necessitates the wrapping of a large number of packages of food in the manner described above.

It is therefore a general object of the present invention to provide an improved apparatus for facilitating the manual wrapping of food.

Another object of the present invention is to provide an improved apparatus for manually wrapping food in sealed, transparent packages.

Another object is to provide an improved wrapping apparatus especially adapted for manually performing a diamond wrapping operation.

Another object is to provide an improved wrapping apparatus especially adapted for thermally sealing the packaging material.

Another object is to provide an improved tray for holding wrapping paper.

Another object is to provide an improved tray especially adapted to present paper to the operator for performing a diamond wrap.

Another object is to provide an improved tray for holding sheets of wrapping paper of the same size in a neat and evenly stacked pack.

Another object is to provide an improved tray for holding sheets of wrapping paper in a pack from which the sheets may be removed individually without disturbing the remaining sheets.

Another object is to provide a tray for holding sheets of wrapping paper equipped with an improved mechanism for piercing a pack of the paper to hold it in a neat and even pack while the sheets are being removed individually.

A further object is to provide a tray for holding sheets of wrapping paper, equipped with flanges disposed to cooperate with a piercing mechanism to hold the paper in a neat and even pack without interfering with the removal of the sheets from the tray individually by the operator.

A further object is to provide a simple and inexpensive tray of sturdy construction but efficient in operation for holding sheets of wrapping paper in a pack.

According to this invention the improved wrapping apparatus includes an especially adapted table upon which

2

the wrapping operation is performed. The wrapping material is furnished in sheets of uniform size, a pack of which is placed in a tray setting upon the top of the table. The tray is provided with a bracket at one corner having a thread hole with a vertical axis for receiving a thumb screw, the lower portion of which is pointed or provided with a coaxial drill bit to act as a piercer for piercing the pack of paper on the tray to hold it in position. The two sides of the tray adjoining the piercer are provided with upwardly extending flanges which cooperate with the piercer to hold the paper in a neat and even pack. The sheets may be removed from this tray individually, simply by tearing them off of the piercer, which will function with the flanges to retain the remaining sheets in an even stack while the individual sheets are being removed.

The table is especially adapted to cooperate with the tray for the convenience of the operator to enable the wrapping operation to be performed manually with maximum efficiency. To this end the table includes a vertically adjustable abutment bar or article-positioning stop extending above the top of the table to present a surface against which the merchandise may be abutted to position it relative to the wrapping material in the tray which is properly located on the table with respect to the abutment bar.

With the merchandise thus positioned against the abutment bar it will be resting upon one corner of the wrapping material. Its diagonally opposite corner may then be torn from the piercer and brought over the top of the merchandise so that the wrapping material embraces the merchandise with two diagonally opposite corners brought together at the bottom of the package. The package is then placed upon a hot plate conveniently mounted on the table, to apply heat to these two corners of the wrapping material to fuse the material and bind the corners together. The other two corners of the wrapping material will then be extending from opposite sides of the package from where they are also folded to its underside. The package is then again placed upon the hot plate to bind the four corners of the wrapping material together at the underside of the package to securely seal the package while presenting a smooth expanse of wrapping material over its top for a neat appearance and an unobstructed view of its contents.

The foregoing and other object of the invention, which will become apparent from the following detailed description setting forth an illustrative embodiment, may be achieved by the particular apparatus depicted in and described in connection with the accompanying drawings, in which:

Figure 1 is a fragmentary perspective view of a wrapping apparatus embodying the features of the present invention;

Figure 2 is a view in side elevation of the wrapping material tray shown on the table in Figure 1;

Figure 3 is a fragmentary plan view of the wrapping material tray illustrated in Figure 2; and

Figure 4 is a fragmentary detail view in front elevation illustrating the vertically adjustable abutment bar, shown assembled to the table in Figure 1.

Reference is now made more particularly to the drawings, and specifically to Figure 1 thereof showing a wrapping apparatus embodying the features of the present invention. As there shown, the wrapping apparatus comprises a table generally identified by the reference numeral 5, and having a top 6 underneath which are disposed a plurality of shelves 7 which may be used as desired for storage purposes.

Since the ideal material for wrapping food is transparent to permit the customer to view its contents, cellophane has been found to function very satisfactorily for

this purpose. In addition to its transparency, it has the further advantage of being readily sealed by heat to fuse the adjacent sheets and thereby bind together. The wrapping material is furnished in sheets 10 of the desired size which are placed in a wrapping material tray generally identified by the reference numeral 11.

The tray 11 rests upon the top 6 of the table 5 in operating position and comprises a bottom plate 12 upon which the sheets 10 rest. Two adjoining edges of the plate 12 have upstanding flanges 13 which serve to prevent lateral pivotal movement of the sheets 10 which are retained on the tray 11 by a piercer 17 extending through the entire pack of the sheets 10 at one corner of the pack.

The piercer 17 is disposed at the corner of the plate 12 at which the flanges 13 join, and extends coaxially from a thumb screw 18. It is shown in the drawings as a drill bit which will function very well for piercing the pack of sheets 10, but a pointed rod will also serve the purpose satisfactorily under most conditions. The thumb screw 18 is in threaded engagement with a threaded opening in a triangular shaped plate 19 supported by an angular bracket 20. The plate 19 is secured to the upper end of the bracket 20 within its interior angle, and the bracket 20 in turn is fixed to the adjoining ends of the flanges 13, extending upwardly from the plate 12. A corner plate 21 is attached to the underside of the plate 12 at the location of the piercer 17 to reinforce the structure at this point.

In operation, the piercer 17 is raised to an upper position, and the pack of sheets 10 are placed upon the plate 12 with a corner of the pack disposed in the corner occupied by the piercer 17, and its adjoining sides bearing against the flanges 13. The thumb screw 18 is then rotated to move the piercer 17 downwardly into the pack of sheets 10 to pierce the entire pack and contact the plate 12. The piercer 17 thus serves to retain the sheets 10 on the plate 12, and the flanges 13 will prevent their lateral movement so that they will be held in a very neat and even pack. The sheets may be torn individually from the piercer 17 without disturbing the remaining sheets which will continue to be held in position by the piercer 17 and flanges 13.

The table 5 is especially adapted to cooperate with the tray 11 to facilitate the manual performance of the wrapping operation. To this end it is provided with a vertically adjustable abutment bar 25 against which the merchandise may be placed in abutment to properly locate it with respect to the wrapping material in the tray 11. The abutment bar 25 is supported along a short side of the table 5 for vertical adjustment so that its height may be varied to accommodate the various heights of merchandise that may be wrapped.

The abutment bar 25 is rendered adjustable by a pair of elongated slots 27 formed in its face for receiving a pair of mounting screws 28 which may be tightened to rigidly secure the abutment bar 25 in the desired vertical position within the length of the slots 27.

As previously mentioned, heat is applied to the wrapping material to fuse it for the purpose of sealing the package. To this end a hot plate 30 is provided, including the usual electric heating element 31 embedded in aluminum or other suitable heat conducting material. Electrical energy for energizing the heating element 31 is carried by conductors 32 from a suitable source (not shown), and the circuit also includes a thermostat (not shown) to control the flow of current to the heating element for regulating the temperature of the hot plate 30 for optimum efficiency.

The hot plate 30 rests upon an auxiliary table 35 supported by a pair of angle irons 36 extending parallelly from the table top 6 and secured to the structural framework of the table 5. The auxiliary table 35 is spaced from the table top 6 a sufficient distance to provide room for manipulating the corner of the sheet 10 over the top of the package when performing the wrapping operation.

The wrap which produces the neatest package is known in the trade as the diamond wrap in which the wrapping material is cut into square sheets and is wrapped around the merchandise so that diagonally opposite corners of the sheet are brought together, preferably at the underside of the package. The wrapping apparatus of the present invention is especially adapted to facilitate the completion of the diamond wrap.

To perform the diamond wrap, the tray 11 with the sheets 10 is placed upon the table top 6 so that a diagonal line of the sheets 10 is approximately perpendicular to the abutment bar 25, with the corner held by the piercer 17 being disposed the furthest from the abutment bar 25. The corner of the sheet 10 diagonally opposite the piercer 17 is located from the abutment bar 25 a distance less than half of the width of the article being wrapped, with the exact distance varying to suit the particular conditions, taking into consideration the size of the article being wrapped and the size of the sheet 10 being used.

With the tray 11 and its sheets 10 thus positioned, it is only necessary to place the article being wrapped upon the pack of sheets 10 with its longitudinal side in abutment with the abutment bar 25 as shown in Figure 1. This will automatically locate the article so that it rests upon a corner of the sheet 10 with the corner extending beneath the article beyond its mid-point. It is then only necessary to tear the diagonally opposite corner from the piercer 17 and bring it over the top of the article and downwardly over the abutment bar 25 as illustrated in Figure 1 where a sheet is shown thus positioned over an article disposed against the abutment bar 25.

The article may then be grasped to hold the one corner of the sheet 10 underneath it while it is being raised from the table top 6, and the opposite corner is folded underneath the article also to bring the two diagonally opposite corners of the sheet 10 together at the bottom of the article with the corners overlapping. The article may then be placed momentarily on the hot plate 30 to apply heat to these two corners at the bottom of the package for the purpose of fusing them together, leaving the other two corners of the sheet 10 extending from the ends of the article as indicated at 40 in Figure 1. These two corners 40 are simply folded underneath the article to bring them together with the other two corners of the sheet 10 and fused together to seal the package. This latter operation may be performed in the manner most suitable to the operator, but it has been found convenient to fold one of the extending corners 40 to the underside of the package and place it momentarily on the hot plate 30 to fuse it to the two corners of the sheet 10 previously folded to this position. The last extending corner 40 is then folded to the underside of the package and subjected to heat from the hot plate 30 to fuse it, binding the four corners together at the underside of the package to firmly seal it.

In this manner a neat and sanitary package is formed with the four corners of the sheet 10 being out of view on the undersurface of the package, leaving a smooth unobstructed view of its contents. Such a package is ideal for display purposes and is securely sealed, excluding air to avoid deterioration as well as to prevent the contents from being tampered with.

From the foregoing detailed description of the structure and operation of the illustrative embodiment of the present invention, it will be apparent that a new and improved wrapping apparatus has been provided which is especially adapted to facilitate the manual wrapping of food in sealed, transparent packages for placement in self-service food markets.

Although the illustrative embodiment of the present invention has been described in considerable detail for the purpose of making a full disclosure of a practical operative arrangement by means of which the invention may be practiced, it is to be understood that various novel features of the invention may be incorporated in

other arrangements without departing from the spirit and scope of the invention as defined in the subjoined claims.

The principles of the invention having now been fully explained in connection with the foregoing description of the illustrative embodiment, the invention is hereby claimed as follows:

1. A wrapping method for enveloping an article in a rectangular wrapping sheet using a table provided with article locating means and also using a hot plate spaced beyond said article locating means, which method comprises locating a stack of rectangular wrapping sheets on the table with corresponding first corners of each sheet projecting toward the article locating means, corresponding second corners of each sheet diagonally opposite the first corners being directed away from the article locating means; placing an article to be wrapped in predetermined relation to the article locating means and partially on the first corner of the uppermost sheet of the stack; drawing the second corner of the uppermost sheet around and beneath the article into lapping engagement with the first corner of the sheet; and moving the article and the lapping first and second corners of said sheet across a hot plate for the heat sealing of the lapping corners.

2. The method recited in claim 1 followed by the steps of successively drawing third and fourth corners of the wrapping sheet beneath the article and heat sealing them to lapped portions of the sheet on the under side of the article.

3. A method of wrapping an article having a substantially flat bottom, said method comprising the steps of locating the article on a marginal minor portion of the uppermost sheet of a stack of superimposed wrapping sheets, drawing the major portion of said uppermost sheet over and around said article while said minor portion of the sheet remains beneath the article, overlapping said minor portion of the sheet and the end of the major portion of the sheet against the flat bottom of the article, and sealing said overlapped sheet portions against said flat bottom.

4. Apparatus for wrapping an article having a substantially flat bottom, said apparatus comprising a work surface, article locating means at said surface, a tray and a stack of superimposed wrapping sheets in the tray, the tray and article locating means being relatively adjustable to position said stack in such relation to said article locating means that only a marginal minor portion of the uppermost sheet proximate the article locating means will be disposed beneath an article placed on said stack in predetermined relation to the article locating means, the major portion of said uppermost sheet initially remote from said article locating means being adapted to be drawn over said article and around and beneath said article and against the flat bottom thereof to be lapped and sealed to said minor portion of the sheet which remains beneath said article.

5. The apparatus of claim 4 in further combination with heat-sealing means upwardly exposed to the flat bottom of the article and to the portions of the wrapper lapped thereagainst, said heat sealing means being disposed beyond the article locating means and spaced therefrom to leave room for manipulating the wrapper sheet around the article in the course of transfer of the article from said article locating means to the heat sealing means.

6. The apparatus of claim 4 in which the article locating means is disposed at the edge of said work surface whereby the space beyond said edge will accommodate the end of the major portion of the wrapping sheet drawn over the article to dispose it at a level below the article in the course of lapping it against the minor portion of the sheet beneath the article.

7. The apparatus of claim 4 in which the tray and stack of superimposed sheets therein are substantially square in plan, the sides of said tray and sheets being disposed at oblique angles to the article locating means to dispose the diagonals of the sheets at substantially a right angle to the article locating means for effecting a diamond wrap of said article.

8. Apparatus for wrapping an article having a substantially flat bottom, said apparatus comprising a work surface, a tray, a stack of superimposed sheets of wrapping paper in the tray, article locating means on the table, said tray having sides obliquely disposed with respect to said article locating means to dispose the diagonals of the sheets at a right angle to the article locating means, said tray being adjustably disposed with respect to said article locating means to position the tray in such relation to the article locating means that only a corner of the uppermost sheet proximate the article locating means will be disposed beneath an article placed on said stack in predetermined relation to said article locating means, the portion of said uppermost sheet initially remote from said article locating means being adapted to be drawn over said article and around and beneath said article and lapped with respect to said corner portion of the sheet which remains beneath said article and sealed to said corner portion against the flat bottom of the article.

9. Apparatus for wrapping an article having a substantially flat bottom, said apparatus comprising a work surface, a laterally exposed article locating stop, means adjustably positioning a stack of superimposed wrapping sheets in such relation to the stop that only a marginal minor portion of the uppermost sheet proximate the article locating means will be disposed beneath an article in lateral abutment with the stop and on the stack of sheets, the major portion of said uppermost sheet initially remote from said stop being adapted to be drawn over said article and stop and around and beneath said article and against the flat bottom of the article to be lapped and sealed to said minor portion of the sheet which remains beneath the flat bottom of said article.

#### References Cited in the file of this patent

##### UNITED STATES PATENTS

466,075	Bronn	Dec. 29, 1891
682,817	Shamer	Sept. 17, 1901
1,043,626	Ray	Nov. 5, 1912
1,925,176	Dean	Sept. 5, 1933
1,964,083	Rubens	June 26, 1934
2,171,459	Thompson	Aug. 29, 1939
2,248,687	Nakahiro	July 8, 1941
2,482,058	Gannon	Sept. 13, 1949
2,679,194	Ehrenfried	May 25, 1954
2,780,045	Kabrick	Feb. 5, 1957
2,782,580	Iverson	Feb. 26, 1957

##### FOREIGN PATENTS

567,206	France	Feb. 27, 1924
---------	--------	---------------