



INTERNATIONAL APPLICATION PUBLISHED UNDER THE PATENT COOPERATION TREATY (PCT)

<p>(51) International Patent Classification 5 : G03G 15/10</p>	<p>A1</p>	<p>(11) International Publication Number: WO 93/01531 (43) International Publication Date: 21 January 1993 (21.01.93)</p>
<p>(21) International Application Number: PCT/NL91/00243 (22) International Filing Date: 29 November 1991 (29.11.91) (30) Priority data: 727,599 9 July 1991 (09.07.91) US (60) Parent Application or Grant (63) Related by Continuation US 727,599 (CIP) Filed on 9 July 1991 (09.07.91) (71) Applicant (for all designated States except US): SPECTRUM SCIENCES B.V. [NL/NL]; Lange Vijverberg 9, NL-2513 AC The Hague (NL).</p>		<p>(72) Inventors; and (75) Inventors/Applicants (for US only) : LANDA, Benzion [CA/CA]; 10010-119 Street, Edmonton, Alberta T5K 1Y8 (CA). LIOR, Ishaiau [IL/IL]; 21 Bilu Street, 70 400 Ness Ziona (IL). CHATOW, Ehud [IL/IL]; 15 HaAviv Street, 49 100 Petach Tikva (IL). (74) Agent: DE BRUIJN, Leendert, C.; Nederlandsch Octrooibureau, Scheveningseweg 82, P.O. Box 29720, NL-2502 LS The Hague (NL). (81) Designated States: CA, JP, KR, US, European patent (AT, BE, CH, DE, DK, ES, FR, GB, GR, IT, LU, NL, SE). Published With international search report.</p>

(54) Title: LATENT IMAGE DEVELOPMENT APPARATUS

(57) Abstract

Imaging apparatus including a first member having a first surface having formed thereon a latent electrostatic image, the latent electrostatic image including image regions at a first voltage and background regions at a second voltage, a second member charged to a third voltage intermediate the first and second voltages and having a second surface adapted for resilient engagement with the first surface and a third member adapted for resilient contact with the second surface in a transfer region. The imaging apparatus also includes apparatus for supplying liquid toner to the transfer region thereby forming on the second surface a thin layer of liquid toner containing a relatively high concentration of charged toner particles and apparatus for developing the latent image by the selective transfer of portions of the layer of liquid toner from the second surface to the first surface.

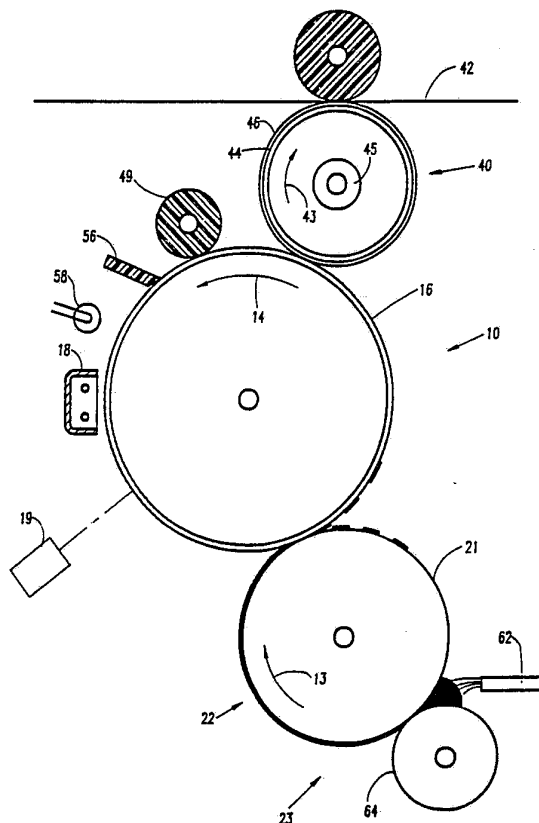

FOR THE PURPOSES OF INFORMATION ONLY

Codes used to identify States party to the PCT on the front pages of pamphlets publishing international applications under the PCT.

AT	Austria	FI	Finland	ML	Mali
AU	Australia	FR	France	MN	Mongolia
BB	Barbados	GA	Gabon	MR	Mauritania
BE	Belgium	GB	United Kingdom	MW	Malawi
BF	Burkina Faso	GN	Guinea	NL	Netherlands
BG	Bulgaria	GR	Greece	NO	Norway
BJ	Benin	HU	Hungary	PL	Poland
BR	Brazil	IE	Ireland	RO	Romania
CA	Canada	IT	Italy	RU	Russian Federation
CF	Central African Republic	JP	Japan	SD	Sudan
CG	Congo	KP	Democratic People's Republic of Korea	SE	Sweden
CH	Switzerland	KR	Republic of Korea	SN	Senegal
CI	Côte d'Ivoire	LI	Liechtenstein	SU	Soviet Union
CM	Cameroon	LK	Sri Lanka	TD	Chad
CS	Czechoslovakia	LU	Luxembourg	TG	Togo
DE	Germany	MC	Monaco	US	United States of America
DK	Denmark	MG	Madagascar		
ES	Spain				

1 **LATENT IMAGE DEVELOPMENT APPARATUS**2 FIELD OF THE INVENTION

3 The present invention relates generally to development
4 apparatus and more particularly to latent image development
5 apparatus in electrophotographic imaging systems.

6 BACKGROUND OF THE INVENTION

7 The method of developing a latent image formed on a
8 photoconductive surface by means of electrophoretic
9 transfer of liquid toner is well known in the art. In this
10 method, charged particles suspended in a non-polar
11 insulating carrier liquid migrate under the influence of
12 an electrostatic field and concentrate in image forming
13 configuration upon relatively charged or discharged areas
14 of a photoconductive surface. The latent image so developed
15 is then transferred to a substrate, such as paper, either
16 directly or by means of one or more intermediate transfer
17 members.

18 In USA Patent 4,504,138 a different method for the
19 developing of a latent image is described. The method
20 described involves applying a thin viscous high density
21 layer of toner particles on the circumferential surface of
22 a roller and bringing the layer so formed to the
23 photoconductive surface. Transfer of selected portions of
24 the toner layer onto the photoconductive surface then
25 occurs as a function of the electric field strength of the
26 latent image.

27 In Canadian Patent 990589, a method of developing
28 electrostatic images is described which involves producing
29 a film of liquid toner on a first applicator and bringing
30 the applicator in contact with the final substrate which
31 carries a latent image, thereby to develop the image. A
32 second applicator bearing a layer of carrier liquid is then
33 brought into contact with the substrate to remove
34 background deposits and to squeegee out excess liquid. The
35 film of liquid toner described in Canadian Patent 990589
36 has between 2 - 4 per cent of toner concentrate dispersed
37 within the carrier liquid.

38

1 SUMMARY OF THE INVENTION

2 It is the object of the present invention to provide
3 simplified apparatus for the development of latent images
4 in electrophotographic imaging systems by the direct
5 transfer of concentrated liquid toner. There is therefore
6 provided imaging apparatus including:

7 a first member having a first surface having formed
8 thereon a latent electrostatic image, the latent
9 electrostatic image including image regions at a first
10 voltage and background regions at a second voltage;

11 a second member charged to a third voltage
12 intermediate the first and second voltages and having a
13 second surface adapted for resilient engagement with the
14 first surface at a first, transfer, region;

15 a third member resiliently urged against the second
16 surface at a second region;

17 means for supplying liquid toner comprising charged
18 toner particles and carrier liquid to the second region,
19 thereby forming on the second surface a thin layer of
20 liquid toner containing a relatively high concentration of
21 charged toner particles;

22 means for developing the latent image by the
23 selective transfer of portions of the layer of liquid
24 toner from the second surface to the first surface at the
25 first region to form a developed image on the first member;
26 and

27 means for transferring the developed image from the
28 first member to a final substrate.

29 There is further provided in a preferred embodiment of
30 the invention imaging apparatus including:

31 a first member including a first surface having formed
32 thereon a latent electrostatic image, the latent
33 electrostatic image having image regions at a first voltage
34 and background regions at a second voltage;

35 a second member charged to a third voltage
36 intermediate the first and second voltages and having a
37 second surface adapted for resilient engagement with the
38 first surface;

1 a third member adapted for depositing on the surface
2 of the second member a thin layer of liquid toner
3 containing a relatively high concentration of charged toner
4 particles;

5 means for obtaining a desired image by selectively
6 transferring portions of the layer of liquid toner from
7 the surface of the second member to the photoconductive
8 surface of the first member, the portions remaining on the
9 surface of the second member constituting the desired
10 image; and

11 means for transferring the desired image to a final
12 substrate.

13 Either or both of the first and second surfaces are
14 preferably formed of resilient material.

15 In one preferred embodiment of the invention the third
16 member is a roller with an elastomer surface, in another it
17 is a resilient blade. In a third preferred embodiment the
18 third member is a spring-mounted wire-wrapped solid rod.
19 Alternatively the third member is an extrusion coating
20 head.

21 Alternatively, in a preferred embodiment of the
22 invention, the third member includes a metallic-screen
23 hollow drum containing liquid toner and a squeegee blade
24 urged against the inner surface of the metallic-screen,
25 preferably also including a doctor blade in engagement with
26 the second surface. Preferably the metallic-screen hollow
27 drum, containing liquid toner, and a squeegee blade form a
28 single disposable unit.

29 Preferably the third member is an integral component
30 of the apparatus for supplying liquid toner.

31 In a preferred embodiment of the invention, the liquid
32 toner supplied to the first transfer region includes toner
33 particles at a concentration comparable to that of the thin
34 layer.

35 In a preferred embodiment of the invention the
36 thickness of the thin layer is between 5 and 15
37 micrometers.

38 In an especially preferred embodiment of the invention

1 the layer of liquid toner is crumbly in texture and almost
2 dry to the touch. Generally such a layer has a solids
3 concentration of more than 50 percent and a thickness of
4 between 2 and 8 micrometers.

5 There is further provided, in a preferred embodiment
6 of the invention, imaging apparatus including:

7 a first member including a first surface having formed
8 thereon a latent electrostatic image, the latent
9 electrostatic image having image regions at a first voltage
10 and background regions at a second voltage;

11 a second member having a second surface and being
12 charged to a third voltage intermediate the first and
13 second voltages;

14 means for resiliently urging the second surface
15 against the first surface at an interface region;

16 means for supplying to the interface region liquid
17 toner comprising a high concentration of charged toner
18 particles in a carrier liquid, whereby the latent image is
19 developed as the liquid toner is extruded between the first
20 and second members; and

21 means for transferring the developed toner image from
22 the first surface to a final substrate.

23 There is further provided, in a preferred embodiment
24 of the invention, a liquid toner developer cartridge,
25 comprising:

26 a housing;

27 a quantity of liquid toner concentrate within the
28 housing, the liquid toner concentrate having a first
29 concentration of solids to liquid; and

30 means for dispensing a thin layer of liquid toner
31 concentrate from the housing, whereby the thin layer has a
32 second concentration of solids to liquid which is greater
33 than the first concentration.

34 The first concentration is preferably at a
35 concentration of greater than 25 percent and the second
36 concentration is crumbly in texture and almost dry to the
37 touch and has a solids concentration of greater than 40
38 percent, desirably more than 50 percent.

1 In a preferred embodiment of the invention, the means
2 for dispensing includes at least two rollers, the first
3 roller having a resilient surface and the second roller
4 having a solid surface. Preferably the two rollers are
5 electrified to different electrical potentials.

6 Preferably, the cartridge includes means for
7 preventing dilution of the quantity of liquid toner
8 concentrate remaining in the housing after the thin layer
9 of toner concentrate has been dispensed therefrom,
10 preferably including capillary means for drawing off excess
11 liquid and a reservoir containing absorbent material for
12 storing the excess liquid.

13 In a preferred embodiment of the invention, a portion
14 of the dispensed layer is not removed from the cartridge
15 and the cartridge includes means for reclaiming and
16 dispersing the unremoved portion.

17 BRIEF DESCRIPTION OF THE DRAWINGS

18 The present invention will be understood and
19 appreciated more fully from the following detailed
20 description, taken in conjunction with the drawings in
21 which:

22 Fig. 1 is a schematic diagram of imaging apparatus
23 constructed and operated in accordance with a preferred
24 embodiment of the present invention;

25 Fig. 2 is a schematic diagram of a multi-color imaging
26 apparatus in accordance with a preferred embodiment of the
27 present invention;

28 Fig. 3A is a more detailed schematic diagram of a
29 developer assembly constructed and operated in accordance
30 with a preferred embodiment of the present invention;

31 Figs. 3B, 3C, 3D, 3E, 3F, 3G and 3H are schematic
32 diagrams of alternative embodiments of developer assemblies
33 constructed and operated according to the present
34 invention;

35 Fig. 4 is a schematic diagram of an additional
36 preferred embodiment of the present invention;

37 Fig. 5 is a schematic diagram of an further preferred
38 embodiment of the present invention;

1 Fig. 6 is a schematic diagram showing toner supply
2 apparatus in accordance with an alternative embodiment of
3 the present invention; and

4 Figs. 7A and 7B are schematic diagrams of an
5 alternative embodiment of a developer assembly constructed
6 and operated according to the present invention.

7 DETAILED DESCRIPTION OF PREFERRED EMBODIMENTS

8 Reference is now made to Fig. 1 which illustrates
9 imaging apparatus constructed and operative in accordance
10 with a preferred embodiment of the present invention.

11 The apparatus of Fig. 1 comprises a drum 10 arranged
12 for rotation in a direction generally indicated by arrow
13 14. Drum 10 preferably has a cylindrical photoconductive
14 surface 16 made of selenium, a selenium compound, an
15 organic photoconductor or any other suitable photoconductor
16 known in the art.

17 When the apparatus is operated, drum 10 rotates and
18 photoconductive surface 16 is charged by a charger 18 to a
19 generally uniformly pre-determined voltage, typically on
20 the order of 1000 volts. Charger 18 may be any type of
21 charger known in the art, such as a corotron, a scorotron
22 or a roller.

23 Continued rotation of drum 10 brings charged
24 photoconductive surface 16 into image receiving
25 relationship with an exposure means such as a light source
26 19, which may be a laser scanner (in the case of a printer)
27 or the projection of an original (in the case of a
28 photocopier). Light source 19 forms a desired latent image
29 on charged photoconductive surface 16 by selectively
30 discharging a portion of the photoconductive surface, the
31 image portions being at a first voltage and the background
32 portions at a second voltage. The discharged portions
33 preferably have a voltage of less than about 100 volts.

34 Continued rotation of drum 10 brings charged
35 photoconductive surface 16, bearing the electrostatic
36 latent image, into operative engagement with the surface 21
37 of a developer roller 22 which is part of developer
38 assembly 23, more fully described below with reference to

1 Figs. 3A through 3H. Developer roller 22 rotates in a
2 direction opposite that of drum 10, as shown by arrow 13,
3 such that there is substantially zero relative motion
4 between their respective surfaces at the point of contact.
5 Surface 21 of developer roller 22 is preferably composed of
6 a soft polyurethane material, preferably made more
7 electrically conductive by the inclusion of conducting
8 additives, while developer roller 22 may be composed of any
9 suitable electrically conductive material. Alternatively,
10 drum 10 may be formed of a relatively resilient material,
11 and in such case surface 21 of developer roller 22 may be
12 composed of either a rigid or a compliant material.

13 As described below, surface 21 is coated with a very
14 thin layer of concentrated paste of liquid toner,
15 preferably containing 15-35% charged toner particles,
16 desirably more than 25% solids. The layer is preferably
17 between 5 and 30 μm , more preferably between 5 and 15 μm ,
18 thick. Developer roller 22 itself is charged to a voltage
19 that is intermediate the voltage of the charged and
20 discharged areas on photoconductive surface 16.

21 In a preferred embodiment of the invention, a
22 concentrated form of liquid toner such as the toner
23 described in Example 1 of U.S. Patent 4,794,651, the
24 disclosure of which is incorporated herein by reference, is
25 used although other types of toner are usable in the
26 invention. For colored toners the carbon black in the
27 preferred toner is replaced by colored pigments as is well
28 known in the art.

29 When surface 21 of developer roller 22 bearing the
30 layer of liquid toner concentrate is engaged with
31 photoconductive surface 16 of drum 10, the difference in
32 voltages between developer roller 22 and photoconductive
33 surface 16 causes the selective transfer of the layer of
34 toner particles to photoconductive surface 16, thereby
35 developing the desired latent image. Depending on the
36 choice of toner charge polarity and the use of a "write-
37 white" or "write-black" system, the layer of toner
38 particles will be selectively attracted to either the

1 charged or discharged areas of photoconductive surface 16,
2 and the remaining portions of the toner layer will continue
3 to adhere to surface 21 of developer roller 22.

4 Because the transfer of the concentrated layer of
5 toner is much less mobility dependent than in normal
6 electrophoretic development, the process described above
7 occurs at a relatively high speed. Also, since the layer
8 already has a high density and viscosity, there is no need
9 to provide for metering devices, rigidizing rollers and the
10 like which would otherwise be necessary to remove excess
11 liquid from the developed image to attain the desired
12 density of toner particles of the developed image.

13 For multicolor systems, as shown in Fig. 2, a
14 plurality of developer rollers may be provided, one for
15 each color, which are sequentially engaged with
16 photoconductive surface 16 to develop sequentially produced
17 latent images.

18 The latent image developed by means of the process
19 described above is then directly transferred to a desired
20 substrate in a manner well known in the art. Alternatively,
21 as shown in Fig. 1, there may be provided an intermediate
22 transfer member 40, which may be a drum or belt and which
23 is in operative engagement with photoconductive surface 16
24 of drum 10 bearing the developed image. Intermediate
25 transfer member 40 rotates in a direction opposite to that
26 of photoconductive surface 16, as shown by arrow 43,
27 providing substantially zero relative motion between their
28 respective surfaces at the point of image transfer.
29 Intermediate transfer member 40 is operative for receiving
30 the toner image from photoconductive surface 16 and for
31 transferring the toner image to a final substrate 42, such
32 as paper. Disposed internally of intermediate transfer
33 member 40 there may be provided a heater 45, to heat
34 intermediate transfer member 40 as is known in the art.
35 Transfer of the image to intermediate transfer member 40 is
36 preferably aided by providing electrification of
37 intermediate transfer member 40 to provide an electric
38 field between intermediate transfer member 40 and the image

1 areas of photoconductive surface 16. Intermediate transfer
2 member 40 preferably has a conducting layer 44 underlying
3 an elastomer layer 46, which is preferably a slightly
4 conductive resilient polymeric layer.

5 Various types of intermediate transfer members are
6 known and are described, for example in U.S. Patent
7 4,684,238, PCT Publication WO 90/04216 and U.S. Patent
8 4,974,027, the disclosures of all of which are incorporated
9 herein by reference.

10 Following the transfer of the toner image to substrate
11 42 or to intermediate transfer member 40, photoconductive
12 surface 16 engages a cleaning station 49, which may be any
13 conventional cleaning station. Scraper 56 completes the
14 removal of any residual toner which may not have been
15 removed by cleaning station 49. A lamp 58 then completes
16 the cycle by removing any residual charge, characteristic
17 of the previous image, from photoconductive surface 16.

18 It is to be understood that, in a preferred embodiment
19 of the invention, the liquid toner concentrate which is
20 transferred to drum 10 has substantially the same toner
21 particle concentration as the image when it is transferred
22 from drum 10. This is in contrast to traditional liquid
23 development where the liquid developer has a comparatively
24 low concentration of particles before development and where
25 excess liquid is removed from the image before transfer
26 from the photoconductor. It is also in contrast to U.S.
27 Patent 4,504,138, in which the toner supplied to the drum
28 (and which is transferred to the drum) is more
29 concentrated, but where excess liquid must still be removed
30 from the image before transfer to the final substrate. In a
31 preferred embodiment of the present invention, the starting
32 toning material is at a solids concentration substantially
33 equal to that of the image transferred from the drum. The
34 toning material may be further concentrated before contact
35 with drum 10 or mechanical squeegeeing may be used to
36 further increase the concentration during the process of
37 transfer of toner to the drum.

38 Reference is now made to Fig. 3A which shows the

1 construction and operation of a preferred developer
2 assembly 23A. Developer assembly 23A comprises a toner
3 dispenser 62 which dispenses liquid toner concentrate onto
4 the surface of a roller 64 arranged for rotation in a
5 direction indicated by arrow 68. Roller 64 is preferably
6 formed of metal and roller 21 is formed of a metal core
7 having a covering of an elastomer material, which is
8 preferably a slightly conductive resilient polymeric
9 material, as described for example, in U.S. Patent
10 3,959,574 or U.S. Patent 3,863,603. Roller 64 may have a
11 very thin coating of polymer material. As it rotates,
12 roller 64 is resiliently urged against surface 21 of
13 developer roller 22, by virtue of a spring 70, and a thin
14 layer of liquid toner concentrate is formed on surface 21
15 of developer roller 22. The thickness of the layer is a
16 function of the pressure applied and the hardness of the
17 surfaces.

18 Roller 64 may also be electrified by a D.C. source to
19 avoid deposition of toner concentrate on roller 64. It may
20 further or alternatively be connected to an AC source,
21 which is operative to reduce somewhat the viscosity of the
22 toner concentrate and generally to cause the deposition of
23 a smoother layer on surface 21 of developer roller 22.

24 In a preferred embodiment of the invention, the liquid
25 toner is supplied at a pre-determined concentration, equal
26 to the concentration of toner particles necessary for the
27 desired optical density of the final image. Supply of the
28 liquid toner concentrate at the pre-determined
29 concentration obviates the need for pumps, tanks, sensors
30 and other costly apparatus which would otherwise be needed
31 in the event a dilute solution of liquid concentrate is
32 provided.

33 In an alternative embodiment, the liquid toner is
34 supplied at a concentration less than that required for
35 optimal development of the latent image. In such event,
36 roller 64 may also function as a mechanical and electrical
37 "squeegee" roller, i.e. when urged against surface 21 of
38 developer roller 22, it mechanically removes excess toner

1 fluid from the layer impressed on surface 21, and when
2 charged with a suitable electric potential, it repels the
3 charged toner particles and causes them to more closely
4 adhere to surface 21. The excess fluid which has been
5 removed is recovered for reuse. Applicants have found that
6 the solids content of the layer is mainly a function of the
7 mechanical properties of the rollers and of the applied
8 voltages and pressures and is only slightly influenced by
9 the initial concentration for a considerable range of
10 initial toner concentrations.

11 As described above, the layer of liquid toner which is
12 deposited by means of roller 64 on surface 21 is
13 selectively transferred to photoconductive surface 16 in
14 the process of developing the latent image. In principle,
15 the system described above does not require that the
16 portions of the toner layer that have not been used in the
17 development of the latent image be removed from developer
18 roller 22 between cycles. However, in the event the toner
19 is of a type which becomes discharged by the electric
20 fields in the interface between the surfaces of developer
21 roller 22 and drum 10, a cleaning station 72 may be
22 provided, which may comprise a brush or comb or similar
23 apparatus, to remove the excess toner concentrate from
24 surface 21 of developer roller 22. The toner so removed may
25 then be pumped back for reuse after mixture with fresh
26 toner, or may be mixed with the toner being fed into the
27 nip between developer roller 22 and roller 64.

28 Reference is now made to Figs. 3B through, 3H, which
29 show alternate embodiments 23B through 23H, of developer
30 assembly 23 in accordance with the invention. Figs. 3B
31 through 3H are identical to Fig. 3A, except that in each
32 case roller 64 has been replaced by a different structure
33 capable of supplying a thin layer of viscous toner
34 concentrate on developer roller 22.

35 In Fig. 3B, roller 64 is replaced by a resilient blade
36 74, which may be composed of the same material as roller 64
37 and which is preferably electrically biased to cause better
38 adhesion of the toner particles to surface 21 and better

1 release from blade 74.

2 In Fig. 3C, roller 64 is replaced by a spring-mounted
3 wire-wrapped solid rod 65, and the coating of surface 21 is
4 accomplished by a "wire-rod" process as is well known in
5 the art. Rod 65 may also be electrically biased.

6 In Fig. 3D, roller 64 is replaced by a metallic-screen
7 drum 74 in which a squeegee blade 75 is mounted and which
8 is urged against the inner surface of the metallic screen
9 74 near its point of contact with developer roller 22.
10 Liquid toner concentrate is supplied to the inside of drum
11 74 and is deposited on surface 21 through the screen when
12 drum 74 is rotated together with roller 22. In a preferred
13 embodiment, the metallic-screen drum together with the
14 squeegee blade and a supply of liquid toner concentrate are
15 supplied as a disposable unit which is replaced when the
16 toner material is depleted.

17 Fig. 3E shows a preferred alternative to the
18 disposable unit described. In the embodiment shown in Fig.
19 3E, toner concentrate is fed to metallic-screen drum 74
20 from a reservoir 80 by pump 82 via conduit 84. The pressure
21 of the toner concentrate in drum 74 is kept substantially
22 constant by pump 82. This pressure is not sufficient to
23 force the toner concentrate through the screen over most of
24 its surface. However during rotation of drum 74 the tip of
25 squeegee blade 75 increases the pressure sufficiently to
26 force the concentrate through the holes to coat roller 22.

27 Alternatively, as shown in Fig. 3F, a replaceable
28 pressurized container 86 of toner concentrate replaces
29 reservoir 80 and pump 82. In the embodiments of Fig. 3E
30 and 3F, drum 74 is preferably not removed when the toner is
31 replenished.

32 In Fig. 3G, roller 64 is replaced by an extrusion
33 coating head 76, which dispenses the liquid toner
34 concentrate in a layer upon surface 21 of developer roller
35 22.

36 Fig. 3H shows an alternative embodiment of the
37 developer assembly in accordance with the invention. The
38 apparatus of Fig. 3H is similar to that of Fig. 3A, except

1 that the liquid toner concentrate is supplied to the
2 interface between the surface of roller 64 and a doctor
3 blade 77. A thin layer of the toner concentrate is formed
4 on the surface of roller 64 which is then transferred in
5 the manner described above.

6 Reference is made to Fig. 4 which shows a cross-
7 sectional schematic view of an alternative embodiment of
8 the invention in which concentrated liquid toner is
9 supplied to an interface between a squeegee roller 120 and
10 drum 10 bearing a latent image. As in the previous
11 embodiments roller 120 and drum 10 are mechanically
12 resiliently urged together. The embodiment of Fig. 4
13 differs from the other embodiments in that a thin layer of
14 concentrated material is formed by extrusion between the
15 squeegee roller and the drum as they roll together and are
16 urged against each other. As seen in Fig. 4 the thin layer
17 immediately separates into image portions which remain on
18 drum 10, and background portions which remain on roller
19 120.

20 Reference is now made to Fig. 5 which shows another
21 embodiment of the apparatus in accordance with the
22 invention. The apparatus of Fig. 5 is similar to that of
23 Fig. 1 except that the apparatus is used for a "reversal"
24 development on roller 22 by the latent image on
25 photoconductive surface 16. In this embodiment, the desired
26 image is formed by the areas of toner concentrate which
27 remain on the surface of developer roller 22 after the
28 development of photoconductive surface 16, and it is
29 developer roller 22 and not drum 10 which is then brought
30 into operative association with an intermediate transfer
31 member (not shown) or a final substrate so as to obtain a
32 print of the desired image. Also shown in Fig. 5 is a pump
33 76 which is operative to pump back for reuse the toner
34 concentrate which has been removed from photoconductive
35 surface 16 by cleaning station 56 at the conclusion of the
36 imaging cycle. Any of the developer assemblies described
37 above may also be used in the context of this embodiment.

38 Reference is now made to Fig. 6, which shows an

1 alternative embodiment of a toner supply apparatus in
2 accordance with the invention. The apparatus of Fig. 6
3 comprises a housing 100 to which arms 108 and 110 are
4 attached. Arms 108 and 110 are adapted to be resiliently
5 urged against surface 21 of developer roller 22. Interior
6 to housing 100 is a piston-like platform 112 which is
7 spring-mounted on the base of housing 100. In operation,
8 housing 100 is filled with liquid toner concentrate which
9 is pushed in the direction of developer roller 22 by the
10 action of a spring 113 on platform 112. Arms 108 and 110
11 serve to contain the liquid toner concentrate from spilling
12 outward, and arm 110 further functions as a blade to meter
13 the deposition of the required amount of liquid toner on
14 surface 21 of developer roller 22. Arm 110 may also be
15 biased electrically as explained above.

16 Alternatively, spring 113 may be replaced by a gas-
17 pressure apparatus which is operative to cause dispensing
18 of the liquid toner concentrate by propelling platform 112
19 in the direction of developer roller 22.

20 In another embodiment of the invention, housing 100
21 together with a supply of liquid toner concentrate and
22 roller 22 may be supplied as a disposable unit, being
23 replaced when the supply of liquid toner concentrate is
24 depleted.

25 Reference is now made to Figs. 7A and 7B which show an
26 alternative embodiment of developer assembly 23 in
27 accordance with a preferred embodiment of the invention. In
28 this embodiment, the developer assembly (including the
29 developer roller and associated elements) is not a fixed
30 component within the imaging apparatus itself, but rather
31 takes the form of a replaceable cartridge 150 which can be
32 readily inserted into the casing of the imaging apparatus
33 (not shown) and removed therefrom when the supply of liquid
34 toner concentrate has been depleted. As shown in greater
35 detail in Fig. 7B, cartridge 150 comprises a housing 152
36 and an internal space 154 containing a supply of liquid
37 toner concentrate. In accordance with a preferred
38 embodiment of the invention, the liquid toner supplied with

1 cartridge 150 contains a relatively high concentration of
2 charged toner particles, on the order of 30%, and carrier
3 liquid. A movable platform 156 is mounted internally to the
4 base of housing 152 by a spring 158, which is at its
5 maximum tension when space 154 is initially filled to its
6 capacity with liquid toner concentrate. The area 160
7 between housing 152 and movable platform 156 may be packed
8 with any suitable liquid-absorbing material, such as a
9 sponge. Platform 156 contains a network of tiny capillaries
10 162 through which excess liquid in space 154 may drip into
11 space 160 and be absorbed by the sponge-like material
12 contained therein.

13 Mounted within housing 152 is a roller 170 which is
14 composed of any suitable electrically conducting material
15 and which has a surface composed of a soft polyurethane
16 material, preferably made more electrically conductive by
17 the inclusion of conducting additives. In a preferred
18 embodiment of the invention roller 170 has a small
19 diameter, desirably less than about 4 cm and preferably
20 about 2.25 cm. The surface of roller 170 protrudes somewhat
21 from the opening of housing 152, such that when cartridge
22 150 is installed in the imaging apparatus, the surface of
23 roller 170 contacts the photoconductive surface of drum 10.
24 When the apparatus is activated, roller 170 is electrically
25 charged and is caused to rotate in the direction indicated
26 by arrow 171. As is more fully described below, a layer of
27 highly concentrated liquid toner is deposited on the
28 surface of roller 170 which then functions as a developer
29 roller with regard to latent images formed on the
30 photoconductive surface of drum 10, in a manner similar to
31 that described above with regard to other embodiments of
32 the invention.

33 In addition to roller 170, cartridge 150 comprises two
34 other rollers, 172 and 174, which are mounted within
35 housing 152 such that the surface of roller 172 contacts
36 the surface of roller 170 at point 182 and the surface of
37 roller 174 contacts the surface of roller 172 at point 184.
38 Rollers 172 and 174 are composed of any suitable

1 electrically conducting material. Roller 172 has a
2 diameter which is significantly smaller than that of roller
3 170. Thus, if roller 170 has a diameter of 2.25 cm., roller
4 172 has a diameter of 1.5 cm.

5 When cartridge 150 is installed and the imaging
6 apparatus is in operation, rollers 172 and 174 are
7 electrically charged and are caused to rotate in a
8 direction opposite that of roller 170 (as indicated by
9 arrows 173 and 175), while they are urged against the
10 resilient surface of roller 170.

11 It is a feature of this embodiment of the invention
12 that the layer deposited on roller 170 has a very high
13 solids concentration of preferably greater than about 40
14 percent and typically between 50 and 60 per cent, when the
15 initial concentration of solids in space 154 is preferably
16 above 25% and typically about 30 per cent. This layer of
17 toner has been found to be almost dry to the touch, non-
18 flowing and crumbly in texture. It has also been found that
19 the quality of the developed latent image is enhanced
20 greatly as a result, and no additional drying mechanism is
21 needed when the image is transferred to the final
22 substrate. Since so much liquid has been removed from the
23 layer a thickness of 2-8 micrometers on roller 170 is
24 sufficient.

25 Because of the relatively small diameters of rollers
26 170 and 172, a relatively small force of up to 300 gm-
27 force/cm of length applied at the line of contact of
28 rollers 170 and 172 is sufficient. For this force, if
29 negatively charged toner particles are used, roller 170
30 preferably is charged to an electrical potential which is
31 150 volts more positive than that of roller 172 and roller
32 174 is charged to an electrical potential which is 250
33 volts more positive than roller 170.

34 It will readily be seen that since interior space 154
35 of housing 152 is filled with liquid toner concentrate,
36 when the apparatus is activated and rollers 170 and 172
37 rotate, the interaction between roller 170 and 172 at
38 contact point 182 results in the deposition of a

1 concentrated layer of liquid toner on the surface of roller
2 170. Then, as roller 170 continues to rotate, it functions
3 in turn as a developer roller with regard to the latent-
4 image-bearing surface of drum 10, with portions of the
5 layer of the dry to the touch liquid toner concentrate
6 being selectively transferred to the surface of drum 10,
7 thereby developing the latent image, as explained above
8 with regard to the other embodiments of the invention. As
9 described above, because of the squeegee action of the
10 resilient surface of roller 170 at contact point 182, a
11 large proportion of the carrier liquid contained within the
12 toner concentrate is squeezed out as the layer of toner is
13 deposited on roller 170.

14 After portions of the layer of toner concentrate have
15 been transferred to the surface of drum 10 to develop the
16 latent image, the remaining portions of the toner layer on
17 roller 170 continue to rotate on the surface of roller 170
18 until they reach contact point 184 between roller 170 and
19 roller 174. Then, because of the relative electrical
20 potentials on roller 170 and roller 174, the remaining
21 portions of the toner layer are transferred to roller 174
22 at contact point 184. Downstream of contact point 184, a
23 resilient blade 176 which is anchored to the internal wall
24 of housing 152, scrapes off the remaining portions of the
25 toner layer from the surface of roller 174.

26 Because the portions of toner concentrate which are
27 scraped off of roller 174 are dry and crumbly, they will
28 not disperse easily within the liquid toner concentrate
29 remaining in the cartridge. To aid in the dispersion
30 process, a pair of oppositely turning teeth-bearing rods
31 178 and 180 are mounted within housing 152, such that the
32 portions of dry toner scraped off of roller 174 fall
33 between them and are broken apart by the interaction of the
34 teeth on the rods. The turbulence caused by the rotational
35 movement of rods 178 and 180 also aid in the dispersion of
36 the drier portions of the toner within the solution of
37 toner concentrate.

38 As the initial supply of toner concentrate contained

1 within space 154 is gradually depleted in the process of
2 developing the latent image, the action of spring 158
3 causes platform 156 to push the mass of toner concentrate
4 within space 154 in the direction of contact point 182,
5 until space 154 is virtually emptied of toner concentrate.
6 A seal 190 is also provided between housing 152 and roller
7 172, so as to ensure that liquid toner may not be released
8 from cartridge 150 except as a result of the interaction of
9 roller 170 and roller 172 at contact point 182.

10 As a consequence of the fact that a large proportion
11 of the carrier liquid contained within the toner
12 concentrate is squeegeed out when the layer of toner is
13 deposited on roller 170, the concentrate still remaining
14 within space 154 is subject to an ongoing process of
15 dilution, as the concentrate is used up. Were this
16 dilution process allowed to continue unchecked, it could
17 result in an unevenness in the liquid content of the toner
18 layers being deposited on roller 170 as the supply of
19 concentrate was being depleted. It is for this reason that
20 the area 160 between housing 152 and movable platform 156
21 is packed with a sponge-like material and platform 156 is
22 fitted with a network of tiny capillaries 162. Excess
23 carrier liquid in the toner concentrate generated by the
24 squeegee action of rollers 170 and 172 will drain through
25 these capillaries and be absorbed by the sponge-like
26 material, so that at any given time during the life-span of
27 the cartridge, the liquid content of the toner concentrate
28 will remain substantially the same.

29 The developer assembly described with reference to
30 Figs. 7A and 7B may be easily adapted for use with the
31 embodiments of Figs. 1, 2, 4 and 5.

32 Although a variety of toners are suitable, a preferred
33 toner for the embodiments of Figs. 7A and 7B is made in the
34 following method:

35 Compounding

36 36 grams of Picotoner 1278 (Hercules), a styrene
37 acrylate copolymer, is loaded on a Brabender two-roll mill
38 preheated to 160°C. 30 grams of Mogul-L (Cabot) carbon

1 black are added in small amounts during a period of about
2 10 minutes while working of the material is continued. 84
3 grams of Iotec 8030 (EXXON), an acrylic acid ethylene
4 copolymer partial sodium salt, is added during 10
5 additional minutes of compounding. The material is
6 discharged and after it is cooled to room temperature it is
7 shredded in a granulator and then cryogenically ground in a
8 Retsch centrifugal mill. The resulting material is used in
9 the size reduction step.

10 Size Reduction

11 570 grams of powdered material produced by the
12 compounding step is loaded, together with 1330 grams of
13 Norpar-13 (EXXON) in a Union Process size 1S attritor
14 filled with 3/16" carbon steel balls. The material is
15 ground at 20°C and 200 RPM for 16 hours to a median
16 diameter of 2.6 microns as measured by a Shimadzu particle
17 size analyzer. The resulting material is screened through a
18 300 micrometer sieve to remove large particles.

19 The resulting toner concentrate is charged with charge
20 director as is known in the art. A variety of charge
21 directors known in the art are operative in this embodiment
22 of the invention. A preferred charge director is Lubrizol
23 890 (Lubrizol Corporation).

24 Alternatively, the carrier liquid is at least
25 partially replaced by a grease or petrolatum. This material
26 has a high viscosity and is thixotropic, thereby reducing
27 leaks.

28 It will be appreciated by persons skilled in the art
29 that the present invention is not limited to what has been
30 particularly shown and described hereinabove. Rather, the
31 scope of the present invention is defined only by the
32 claims that follow:

33

34

35

36

37

38

1 CLAIMS

2 1. Imaging apparatus comprising:

3 a first member having a first surface having formed
4 thereon a latent electrostatic image, the latent
5 electrostatic image including image regions at a first
6 voltage and background regions at a second voltage;

7 a second member charged to a third voltage
8 intermediate the first and second voltages and having a
9 second surface adapted for operative engagement with the
10 first surface at a first, development, region;

11 a third member resiliently urged against the second
12 surface at a second region;

13 means for supplying liquid toner comprising charged
14 toner particles and carrier liquid to the second region,
15 thereby forming on the second surface a thin layer of
16 liquid toner containing a relatively high concentration of
17 charged toner particles;

18 means for developing the latent image by the
19 selective transfer of portions of the layer of liquid
20 toner from the second surface to the first surface at the
21 first region to form a developed image on the first member;
22 and

23 means for transferring the developed image from the
24 first member to a final substrate.

25

26 2. Imaging apparatus comprising:

27 a first member including a first surface having formed
28 thereon a latent electrostatic image, the latent
29 electrostatic image having image regions at a first voltage
30 and background regions at a second voltage;

31 a second member charged to a third voltage
32 intermediate the first and second voltages and having a
33 second surface adapted for resilient engagement with the
34 first surface;

35 a third member adapted for depositing on the surface
36 of the second member a thin layer of liquid toner
37 containing a relatively high concentration of charged toner
38 particles;

1 means for obtaining a desired image by selectively
2 transferring portions of the layer of liquid toner from
3 the surface of the second member to the photoconductive
4 surface of the first member, the portions remaining on the
5 surface of the second member constituting the desired
6 image; and

7 means for transferring the desired image to a final
8 substrate.

9

10 3. Imaging apparatus according to claim 3 wherein the
11 liquid toner comprises less than 35% charged toner
12 particles.

13

14 4. Imaging apparatus according to claim 1 or claim 3
15 wherein the liquid toner supplied to the second region
16 comprises more than 15% charged toner particles.

17

18 5. Imaging apparatus according to any of claims 1-3
19 wherein the concentration of toner particles in the liquid
20 toner supplied to the second region is substantially the
21 same as in the thin layer of liquid toner.

22

23 6. Imaging apparatus according to any of claims 1-4
24 wherein the concentration of toner particles in the liquid
25 toner supplied to the second region is substantially less
26 than in the thin layer of liquid toner.

27

28 7. Imaging apparatus according to any of the preceding
29 claims wherein the thin layer of liquid toner comprises
30 more than 20% charged toner particles.

31

32 8. Imaging apparatus according to any of the preceding
33 claims wherein the layer of liquid toner is crumbly in
34 texture and almost dry to the touch.

35

36 9. Imaging apparatus according to any of the preceding
37 claims wherein the thin layer of liquid toner has a
38 concentration of toner particles greater than 40 per cent.

- 1 10. Imaging apparatus according to claim 9 wherein the
2 thin layer of liquid toner has a concentration of toner
3 particles greater than 50 per cent.
4
- 5 11. Imaging apparatus according to any of claims 1-7
6 wherein the layer of liquid toner comprises less than 35%
7 charged toner particles.
8
- 9 12. Imaging apparatus according to any of claims 1-10
10 wherein the layer of liquid toner has a thickness between 2
11 and 8 micrometers.
12
- 13 13. Imaging apparatus according to any of claims 1-7 or 11
14 wherein the thin layer has a thickness between 5 and 15
15 micrometers.
16
- 17 14. Imaging apparatus according to any of the preceding
18 claims wherein at least one of the first and second
19 surfaces is formed of a resilient material.
20
- 21 15. Imaging apparatus according to any of the preceding
22 claims wherein the third member is a roller with an
23 elastomer surface.
24
- 25 16. Imaging apparatus according to any of claims 1-7, 11
26 or 13 wherein the third member is a resilient blade.
27
- 28 17. Imaging apparatus according to any of claims 1-7, 11
29 or 13 wherein the third member is a spring-mounted wire-
30 wrapped solid rod.
31
- 32 18. Imaging apparatus according to any of claims 1-7, 11
33 or 13 wherein the third member comprises a metallic-screen
34 hollow drum containing liquid toner and a squeegee blade
35 urged against the inner surface of the metallic-screen.
36
- 37 18. Imaging apparatus according to any of claims 1-7, 11
38 or 13 including a doctor blade in engagement with the

1 second surface.

2

3 19. Imaging apparatus according to any of the preceding
4 claims wherein the third member is an integral component of
5 the means for supplying liquid toner.

6

7 20. Imaging apparatus according to claim 18 wherein the
8 metallic-screen hollow drum containing liquid toner and a
9 squeegee blade form a single disposable unit.

10

11 21. Imaging apparatus according to claim 1 wherein the
12 third member and the means for supplying liquid toner form
13 a single disposable unit.

14

15 22. Imaging apparatus comprising:

16 a first member including a first surface having formed
17 thereon a latent electrostatic image comprising image
18 regions at a first voltage and background regions at a
19 second voltage;

20 a second member charged to a third voltage
21 intermediate the first and second voltages and having a
22 second surface adapted for resilient engagement with the
23 first surface;

24 extrusion coating head means adapted to coat the
25 second surface with a thin layer of liquid toner having a
26 high concentration of toner particles;

27 means for developing the latent image by the
28 selective transfer of portions of the layer of liquid
29 toner from the second surface to the first surface to form
30 a developed image; and

31 means for transferring the developed image to a final
32 substrate.

33

34 23. Imaging apparatus according to claim 22 wherein at
35 least one of first and second surfaces is formed of a
36 resilient material.

37

38 24. Imaging apparatus according to claim 23 wherein the

thickness of the thin layer is between 5 and 15
2 micrometers.

3

4 25. Imaging apparatus comprising:

5 a first member including a first surface having formed
6 thereon a latent electrostatic image, the latent
7 electrostatic image having image regions at a first voltage
8 and background regions at a second voltage;

9 a second member having a second surface and charged to
10 a third voltage intermediate the first and second voltages;

11 means for resiliently urging the second surface
12 against the first surface at an interface region;

13 means for supplying to the interface region liquid
14 toner comprising a high concentration of charged toner
15 particles in a carrier liquid, whereby the latent image is
16 developed as the liquid toner is extruded between the first
17 and second members; and

18 means for transferring the developed toner image from
19 the first surface to a final substrate.

20

21 26. A liquid toner developer cartridge comprising:

22 a housing;

23 a quantity of liquid toner concentrate within the
24 housing, the liquid toner concentrate having a first
25 concentration of solids to liquid; and

26 means for dispensing liquid toner concentrate from the
27 housing having a second concentration of solids to liquid
28 which is greater than the first concentration.

29

30 27. A replaceable liquid toner developer cartridge
31 comprising:

32 a housing;

33 a quantity of liquid toner concentrate within the
34 housing; and

35 means for dispensing a thin layer of liquid toner
36 concentrate from the housing.

37

38 28. A liquid toner developer cartridge according to claim

1 27 wherein the liquid toner concentrate within the housing
2 has a first concentration of solids to liquids smaller than
3 the concentration of the thin layer.

4

5 29. A liquid toner developer cartridge according to claim
6 26 or claim 28 wherein the first concentration is greater
7 than 30 percent and the second concentration is greater
8 than 50 percent.

9

10 30. A liquid toner developer cartridge according to any of
11 claims 26, 28 or 29 wherein the first concentration is less
12 than 35 percent and the second concentration is greater
13 than 50 percent.

14

15 31. A liquid toner developer cartridge according to any of
16 claims 26-28 wherein the dispensed liquid toner concentrate
17 is crumbly in texture and almost dry to the touch.

18

19 32. A liquid toner developer cartridge according to any of
20 claims 26-31 wherein the means for dispensing includes at
21 least two rollers, the first roller having a resilient
22 surface and the second roller having a solid surface.

23

24 33. A liquid toner developer cartridge according to claim
25 32 and including means for electrifying the two rollers to
26 different electrical potentials.

27

28 34. A liquid toner developer cartridge according to any of
29 claims 26-33 and including means for reducing dilution of
30 the quantity of liquid toner concentrate remaining in the
31 housing after liquid toner concentrate has been dispensed
32 therefrom.

33

34 35. A liquid toner developer cartridge according to any of
35 the preceding claims wherein a portion of the dispensed
36 concentrate is not removed from the cartridge and including
37 means for reclaiming the unremoved portion.

38

1 36. A liquid toner developer cartridge according to claim
2 34 wherein the means for preventing dilution comprises
3 capillary means for drawing off excess liquid and a
4 reservoir containing absorbent material for storing the
5 excess liquid.

6

7 37. A liquid toner developer cartridge according to claim
8 36 and further including means for dispersing the
9 reclaimed portion.

10

11 38. A liquid toner developer cartridge according to claim
12 37 wherein the means for dispersing comprises a pair of
13 rods bearing teeth which rotate in opposite directions.

14

15 39. A liquid toner developer cartridge according to any of
16 claims 26-38 and also comprising a developer roller on
17 which the liquid toner concentrate is dispensed.

18

19

20

21

22

23

24

25

26

27

28

29

30

31

32

33

34

35

36

37

38

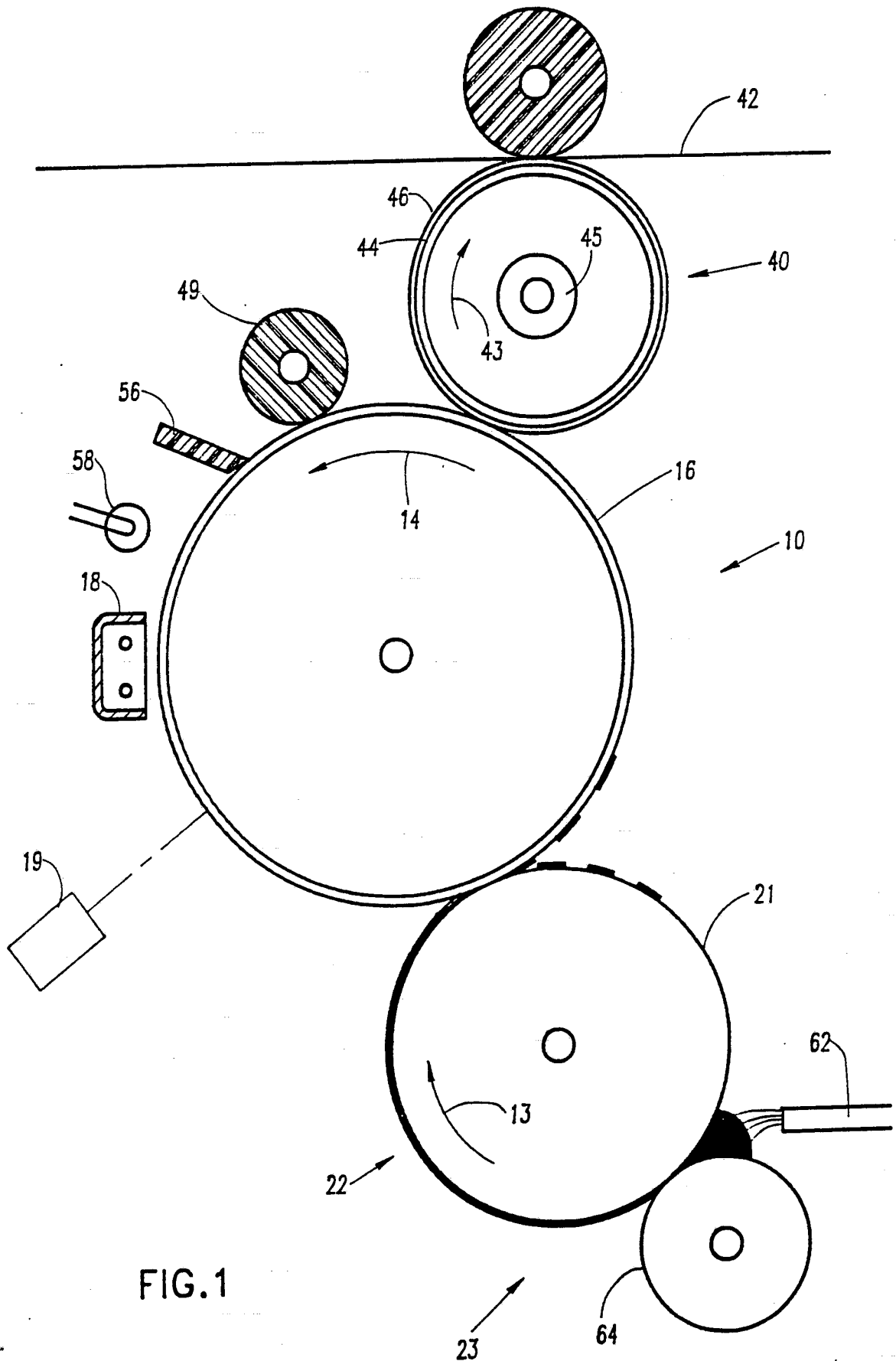

FIG. 1

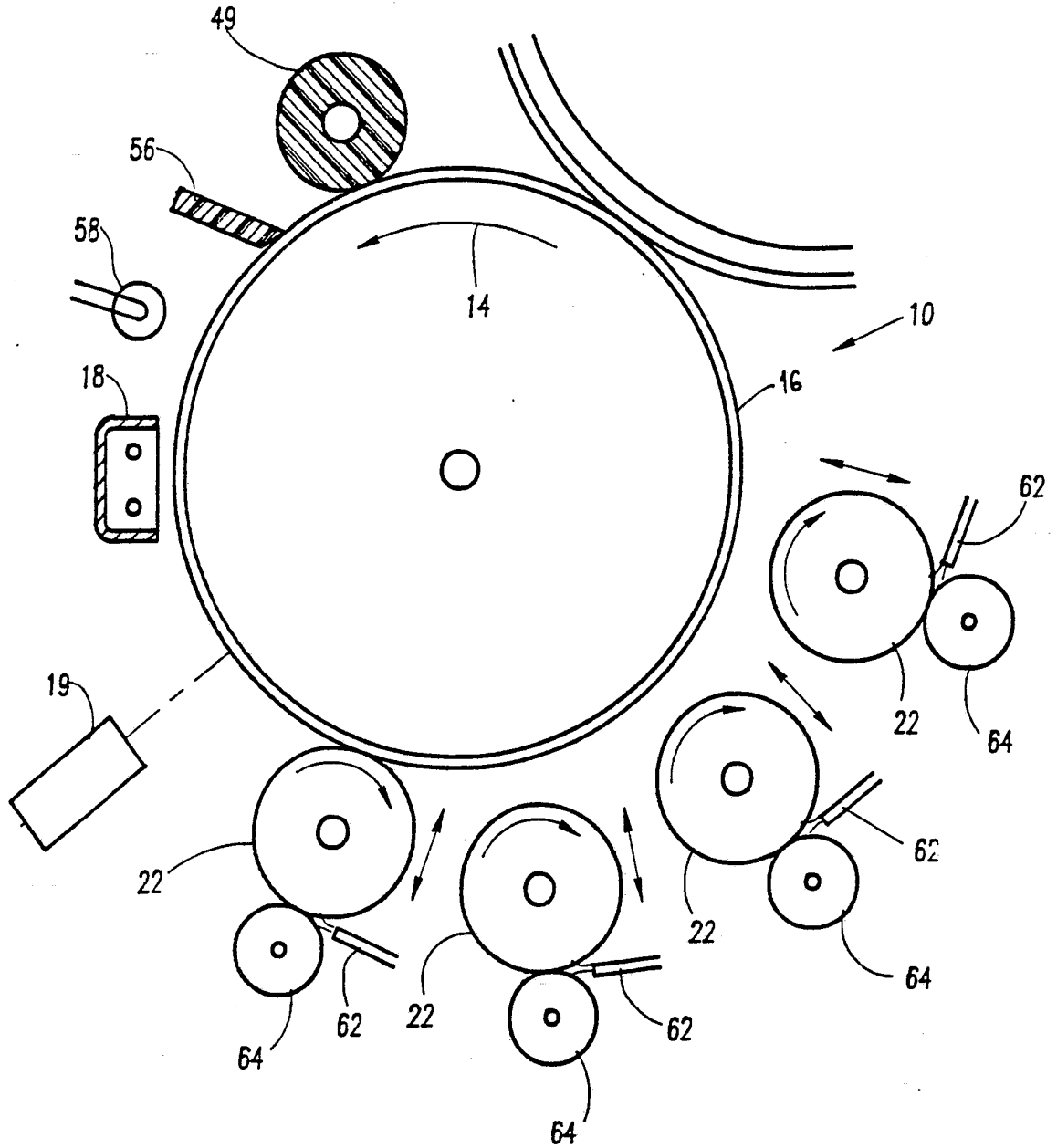

FIG.2

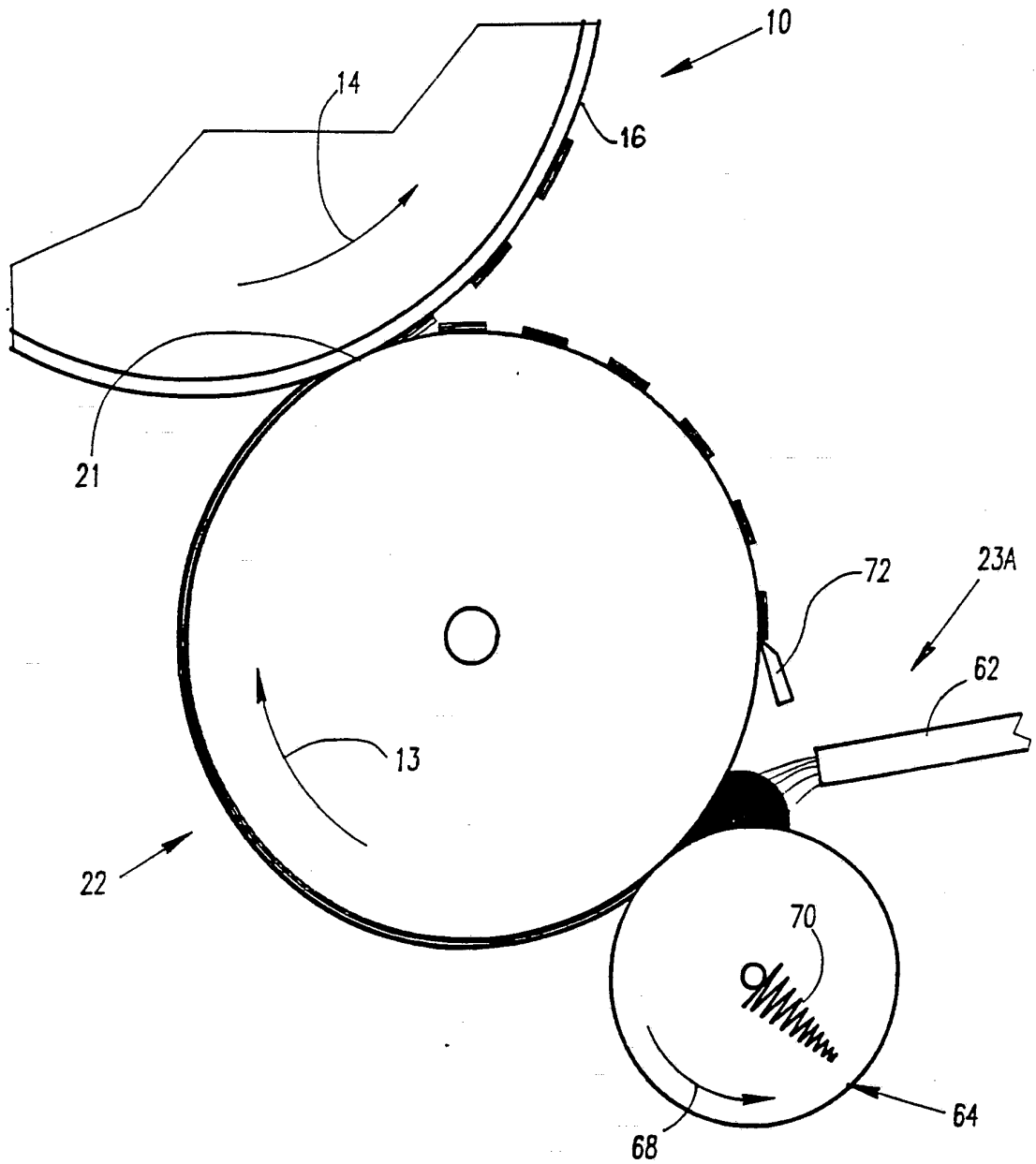

FIG.3A

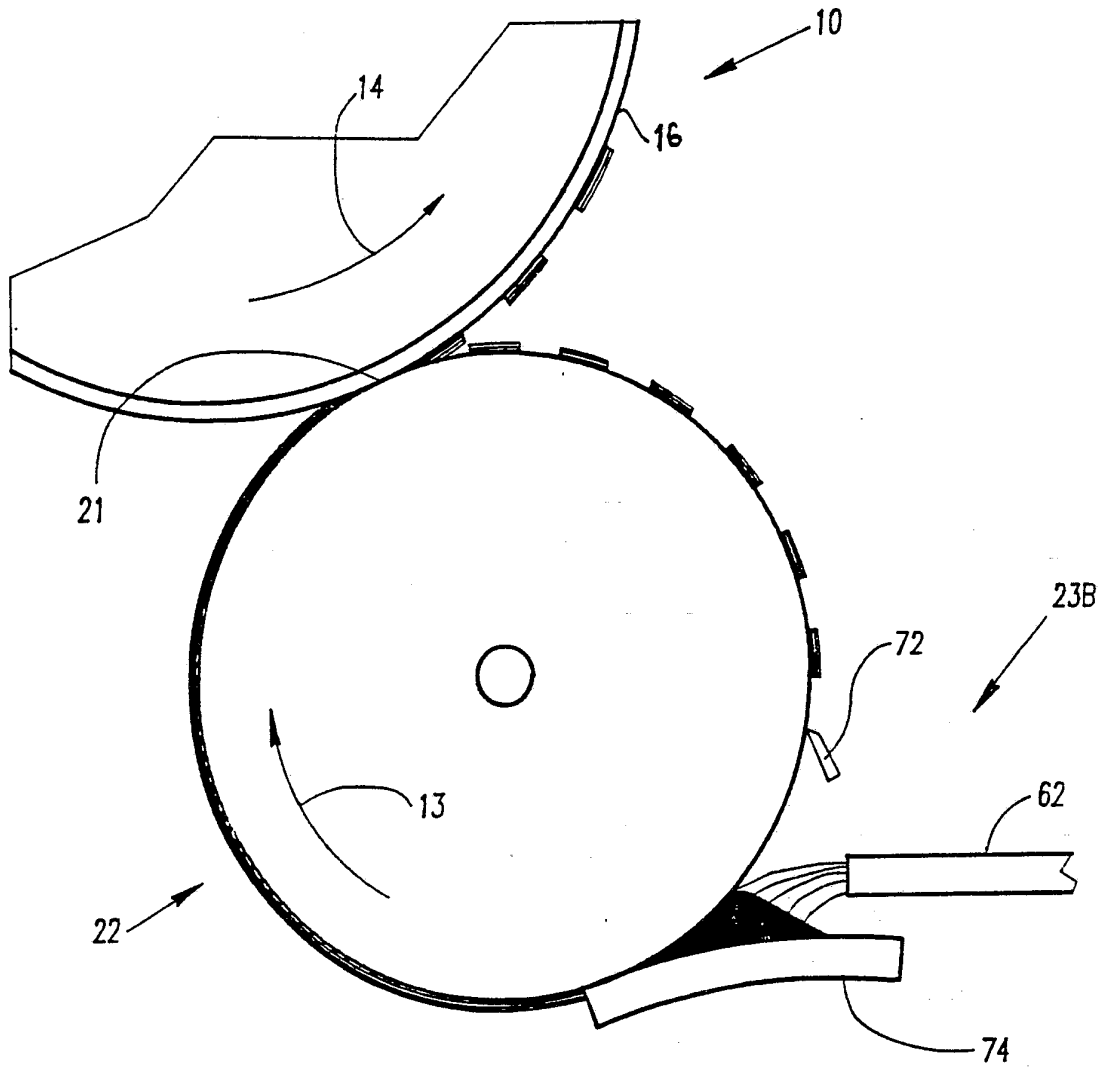

FIG.3B

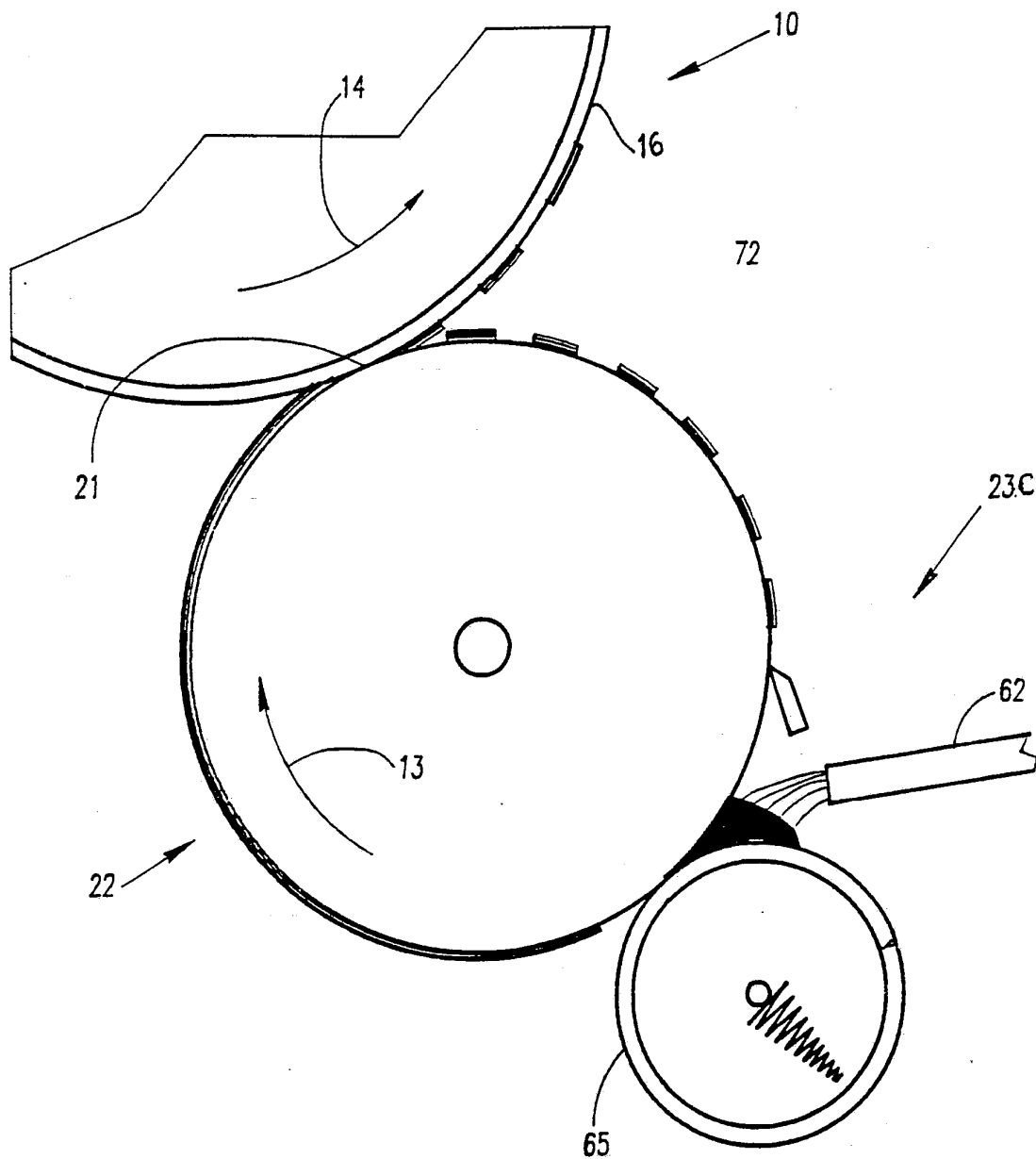

FIG.3C

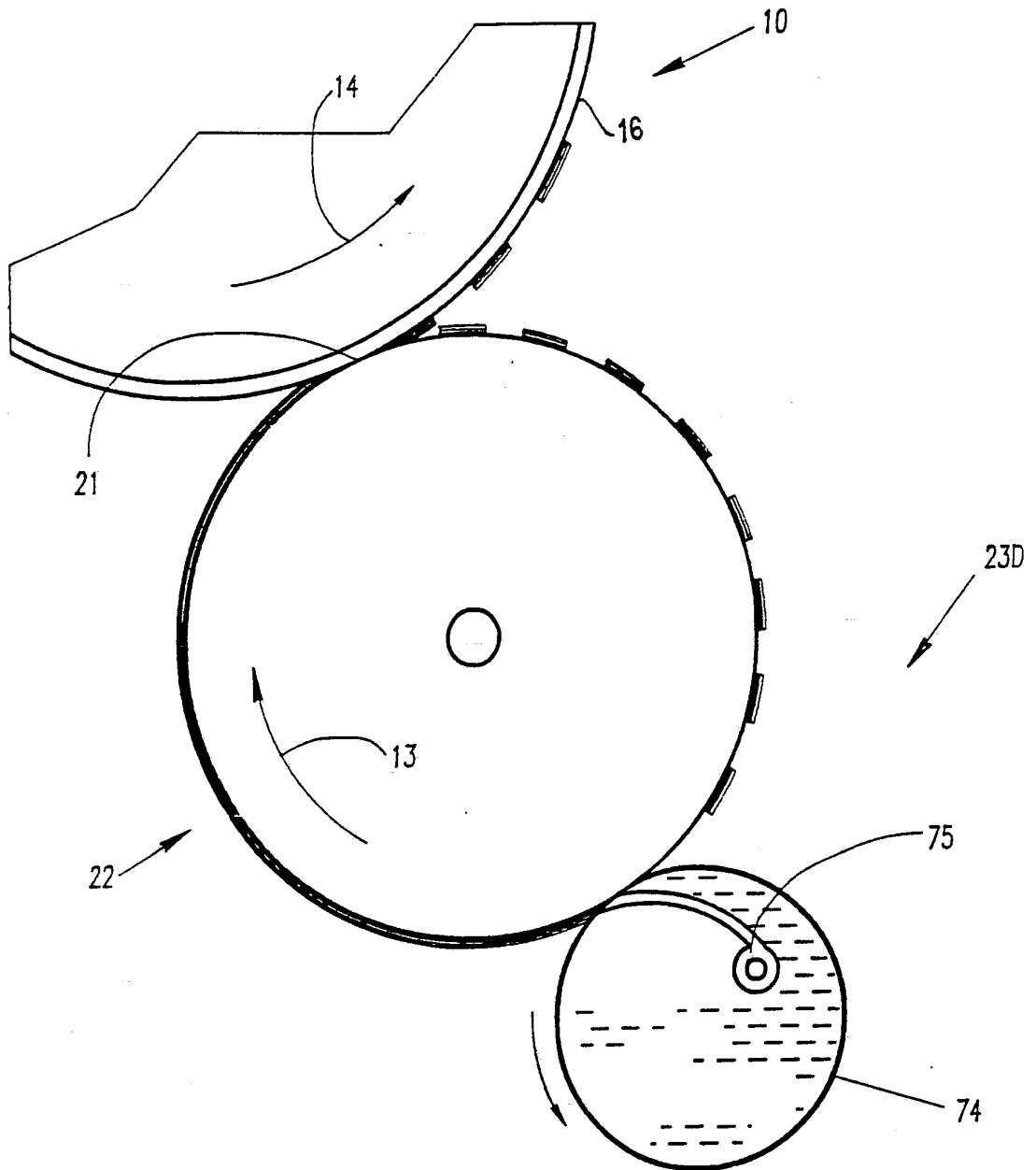

FIG.3D

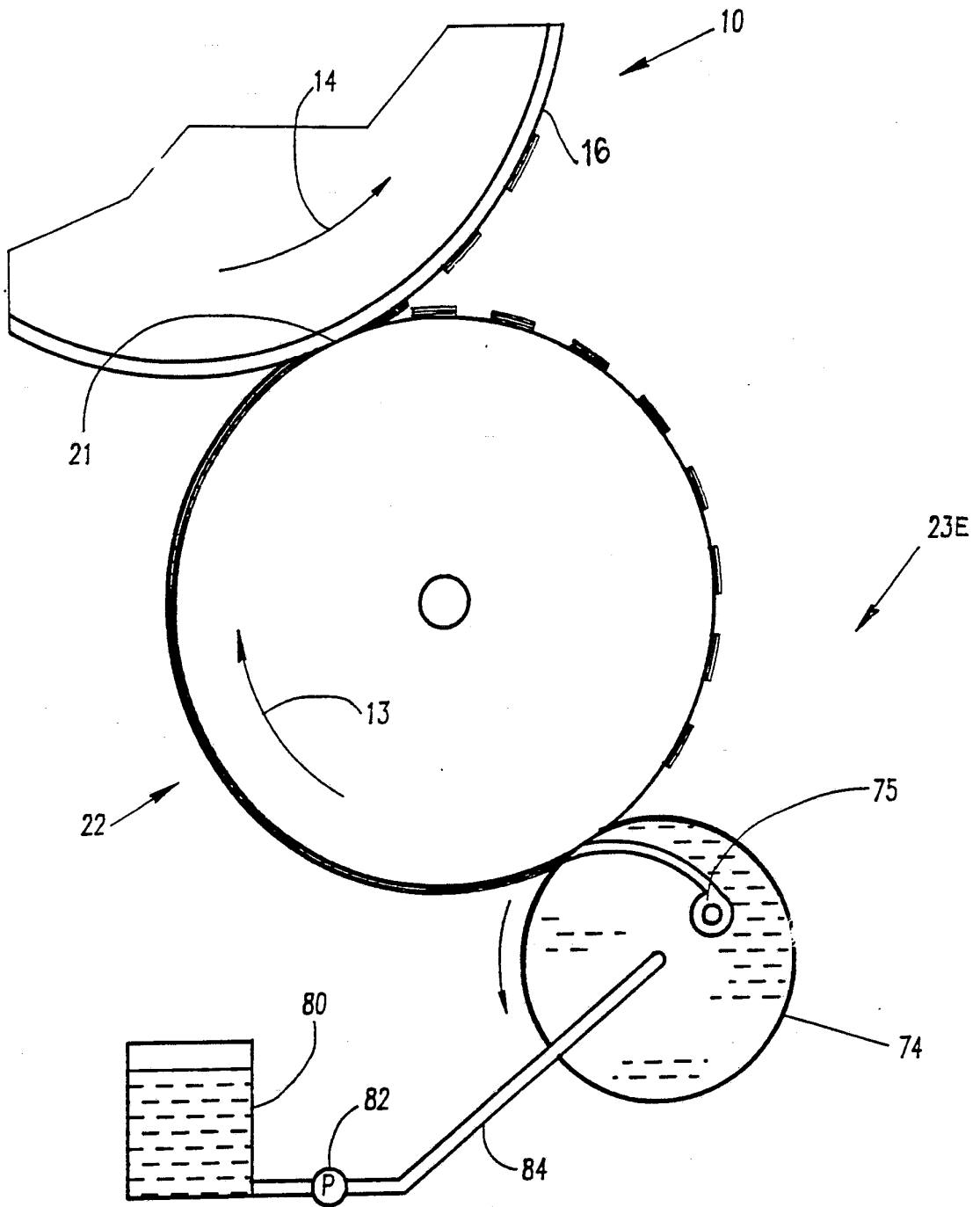

FIG.3E

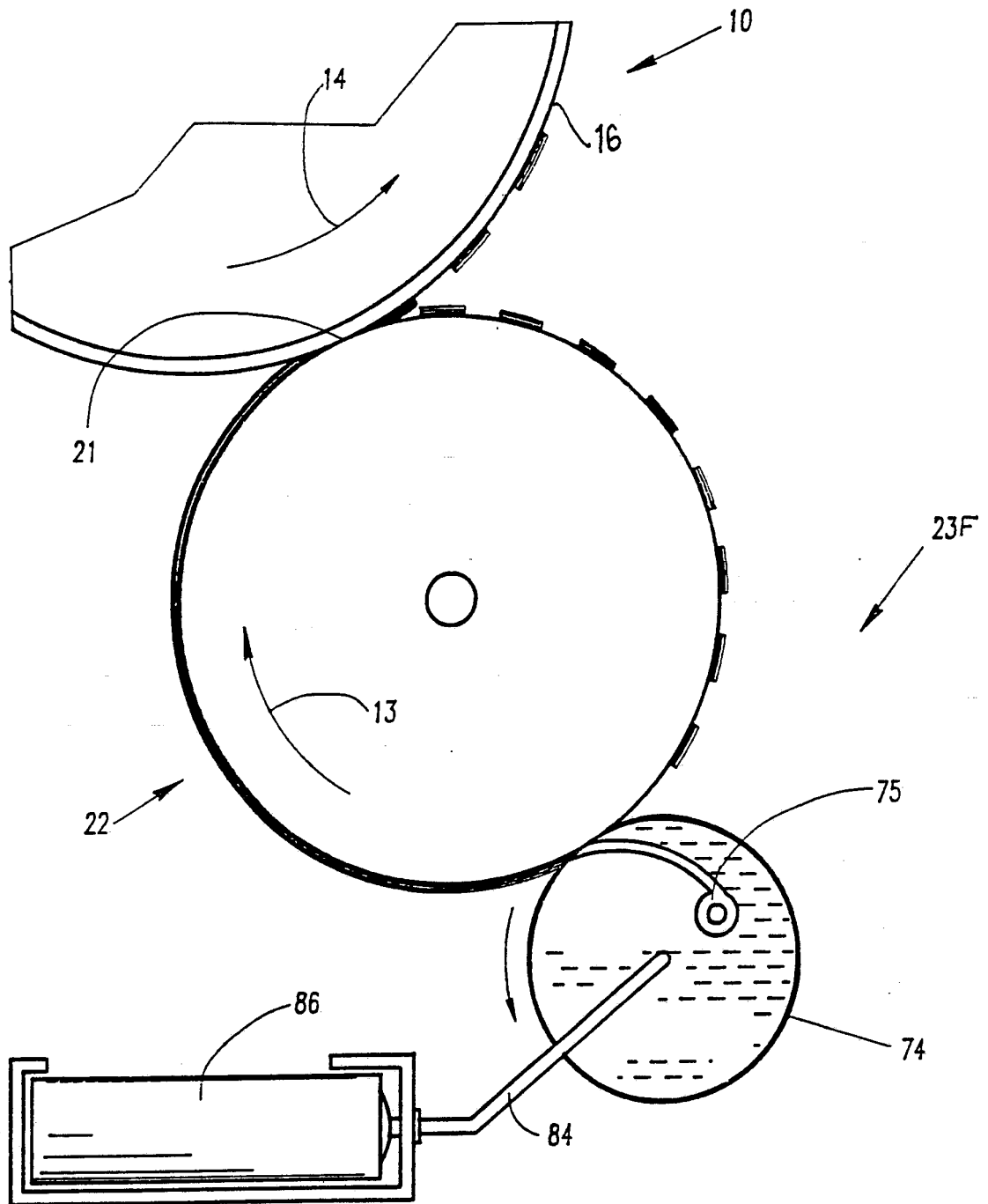

FIG.3F

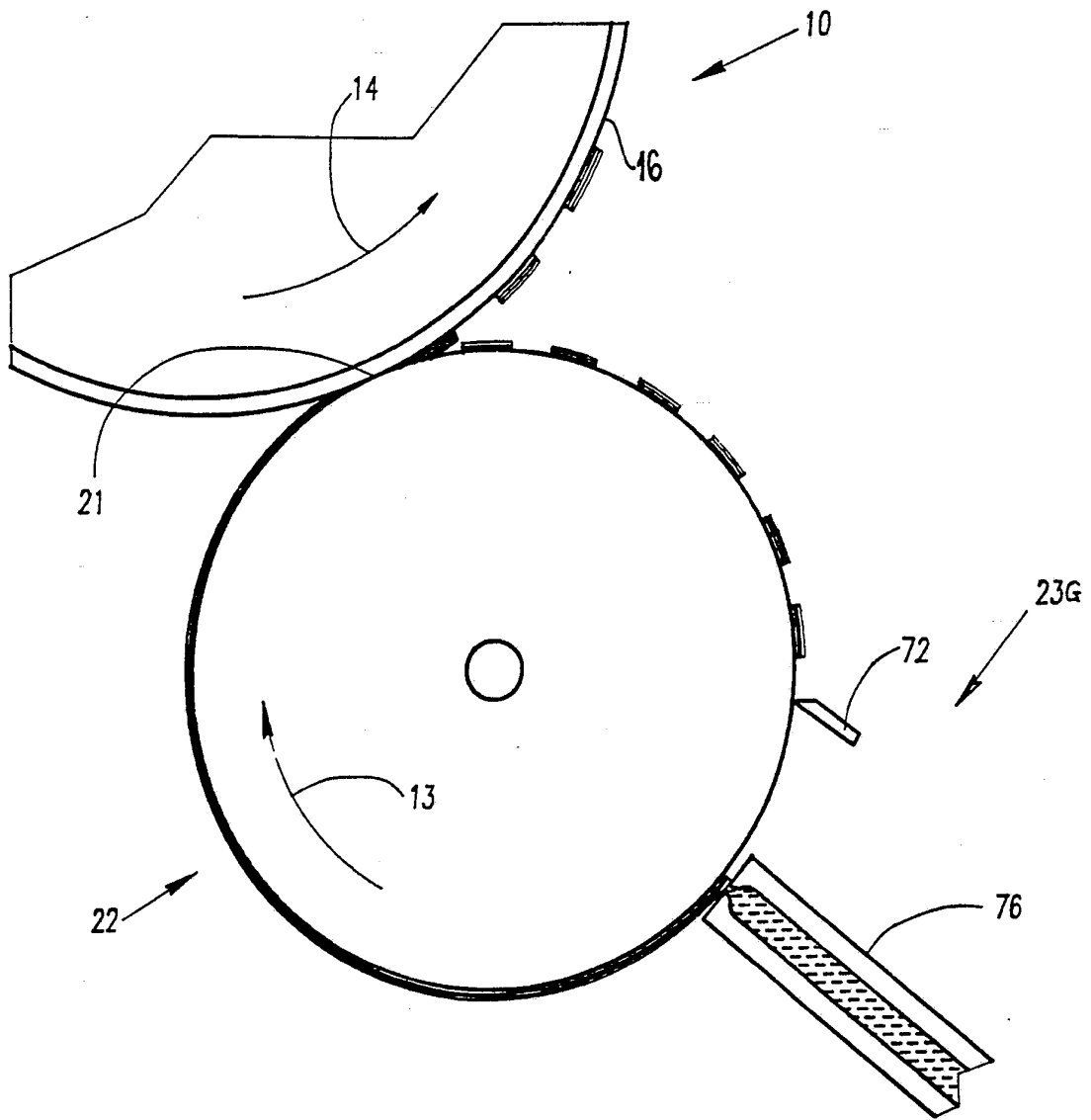

FIG.3G

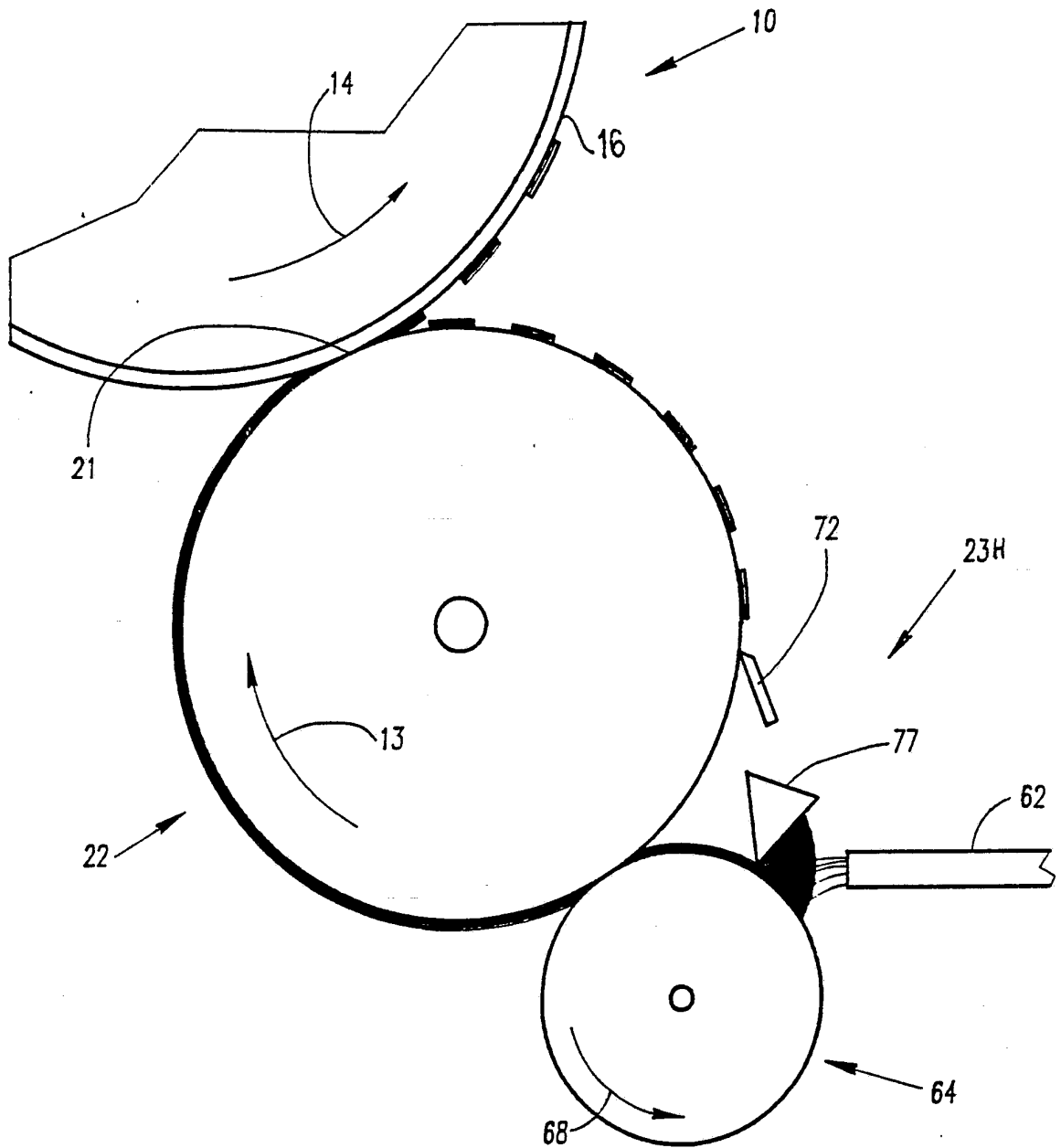

FIG.3H

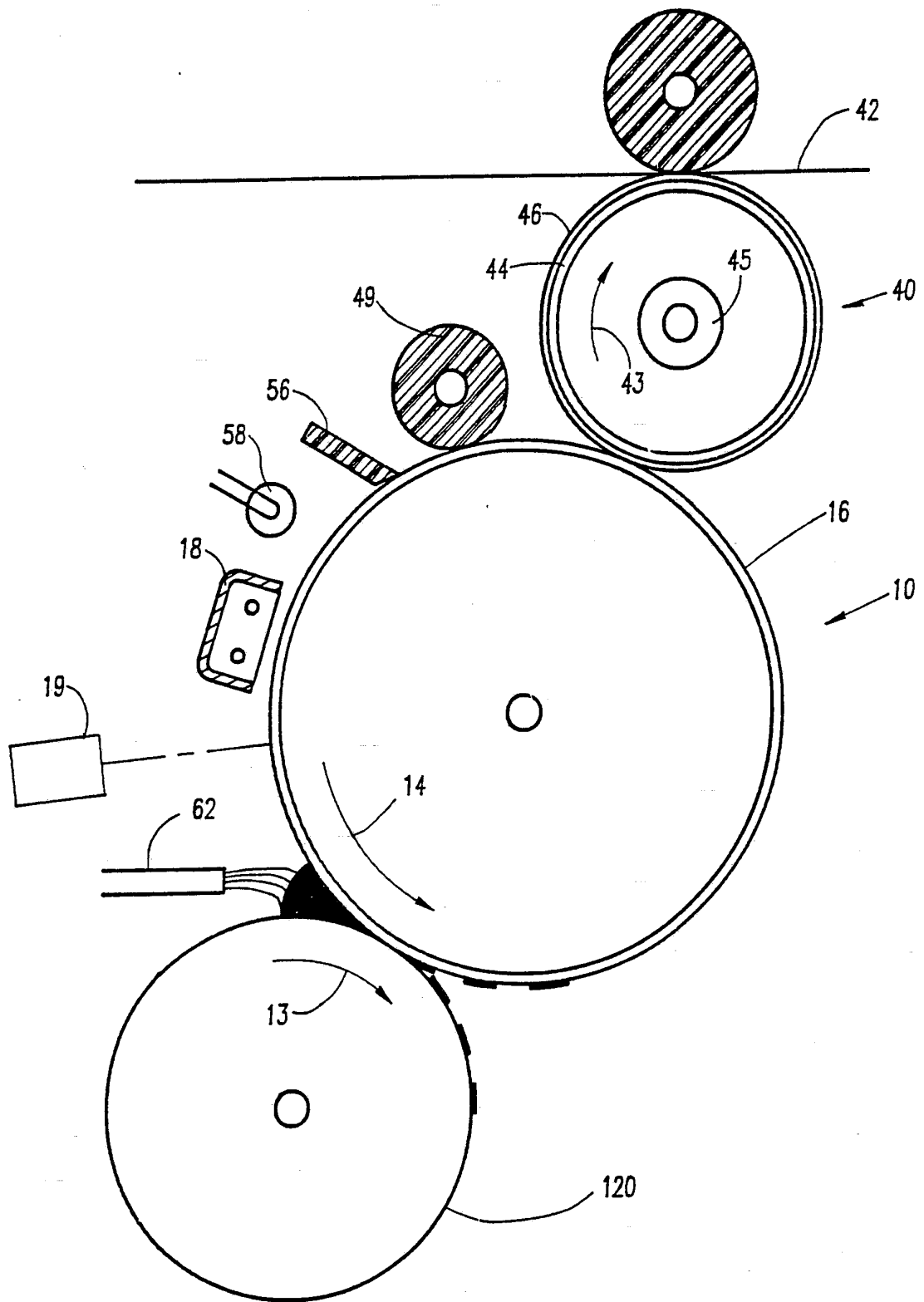

FIG.4

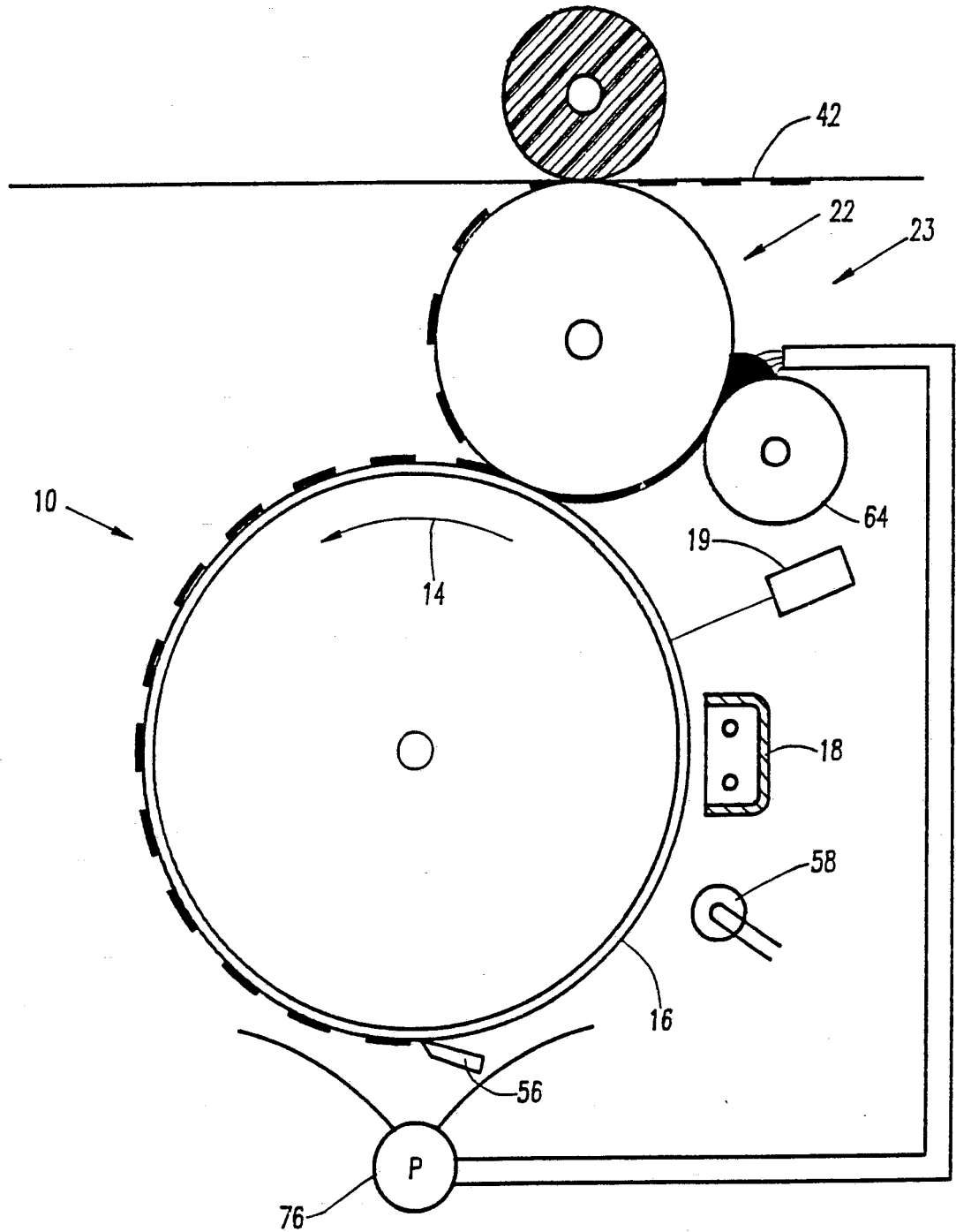

FIG.5

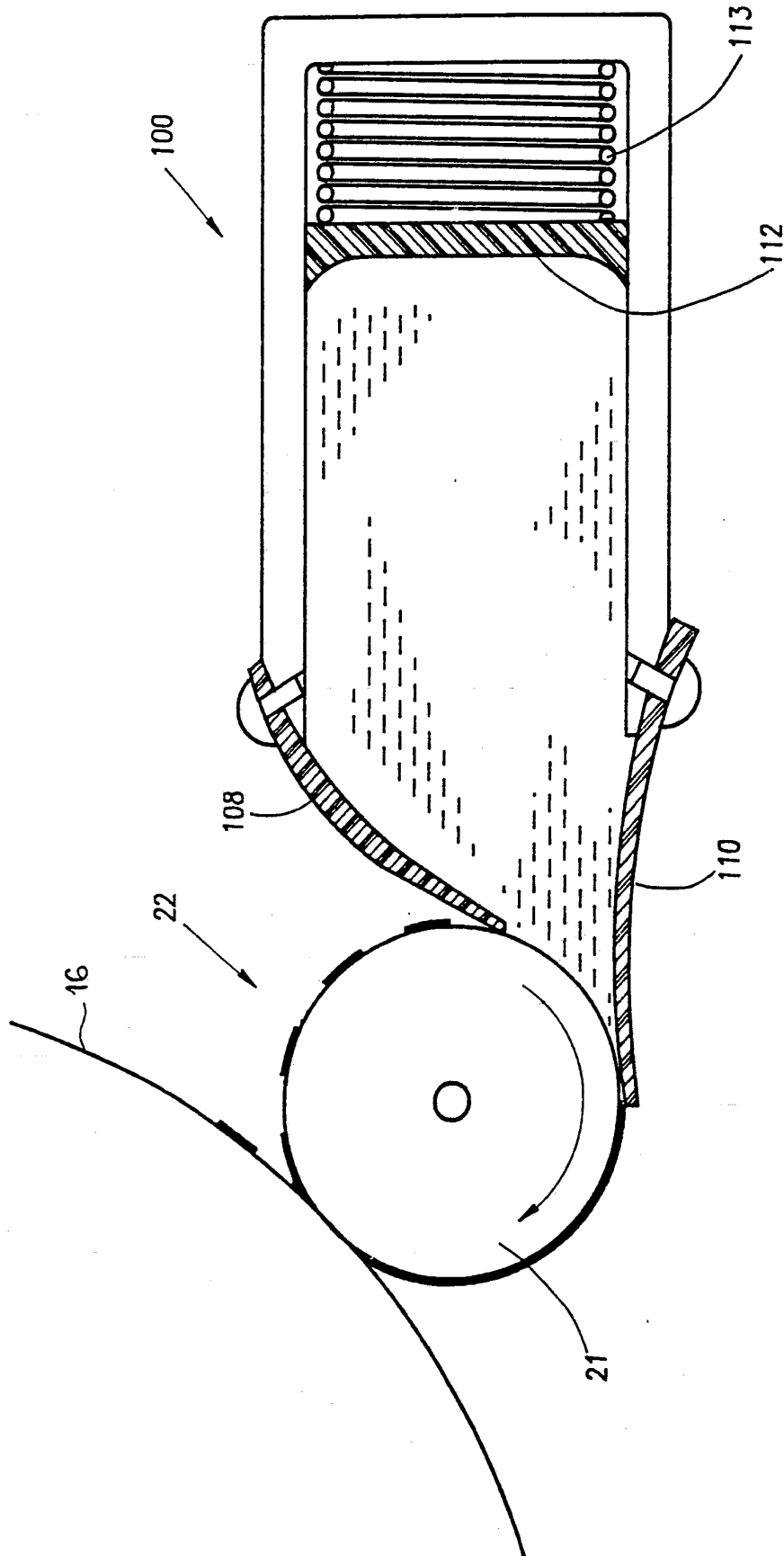

FIG.6

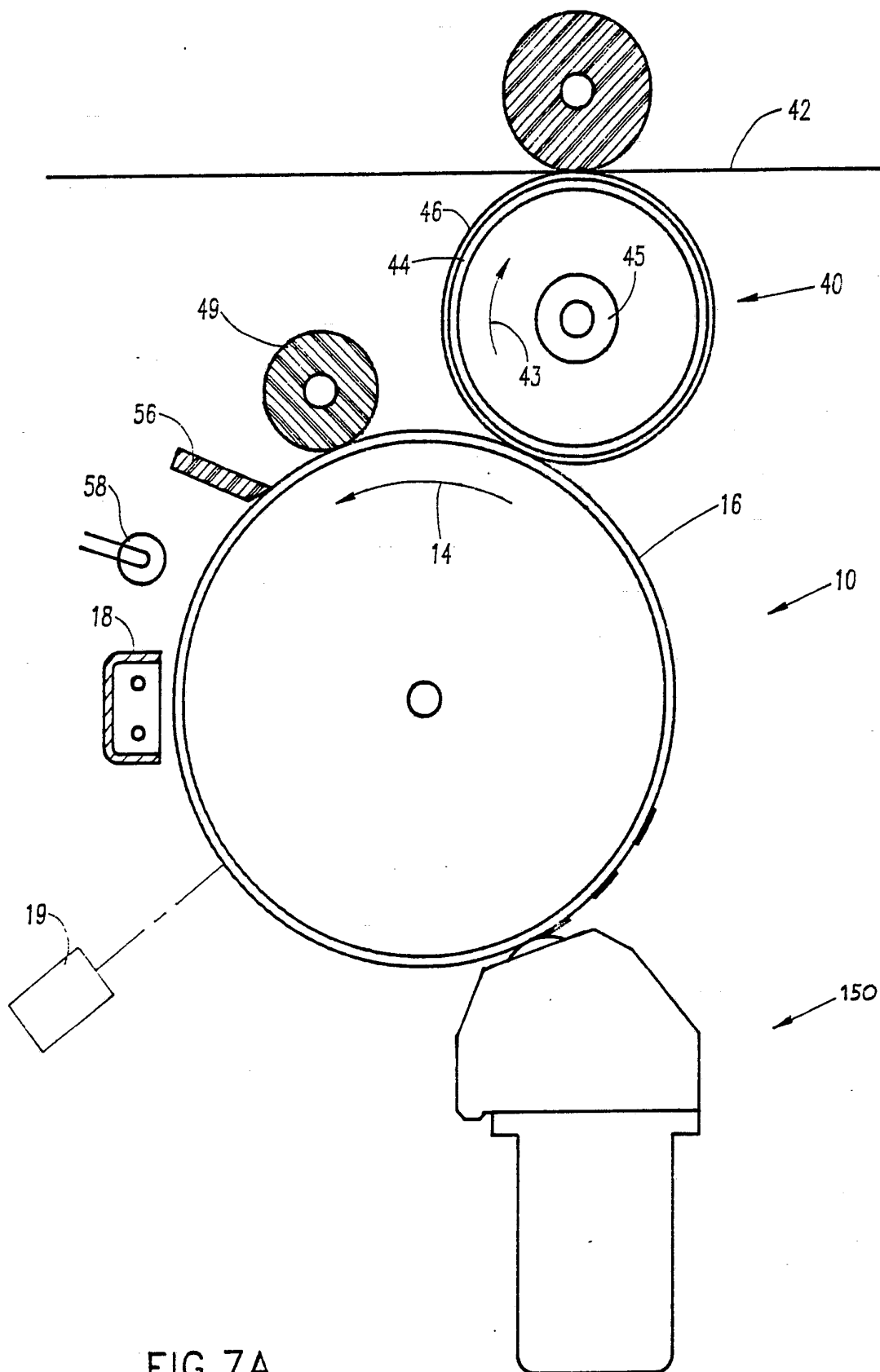

FIG.7A

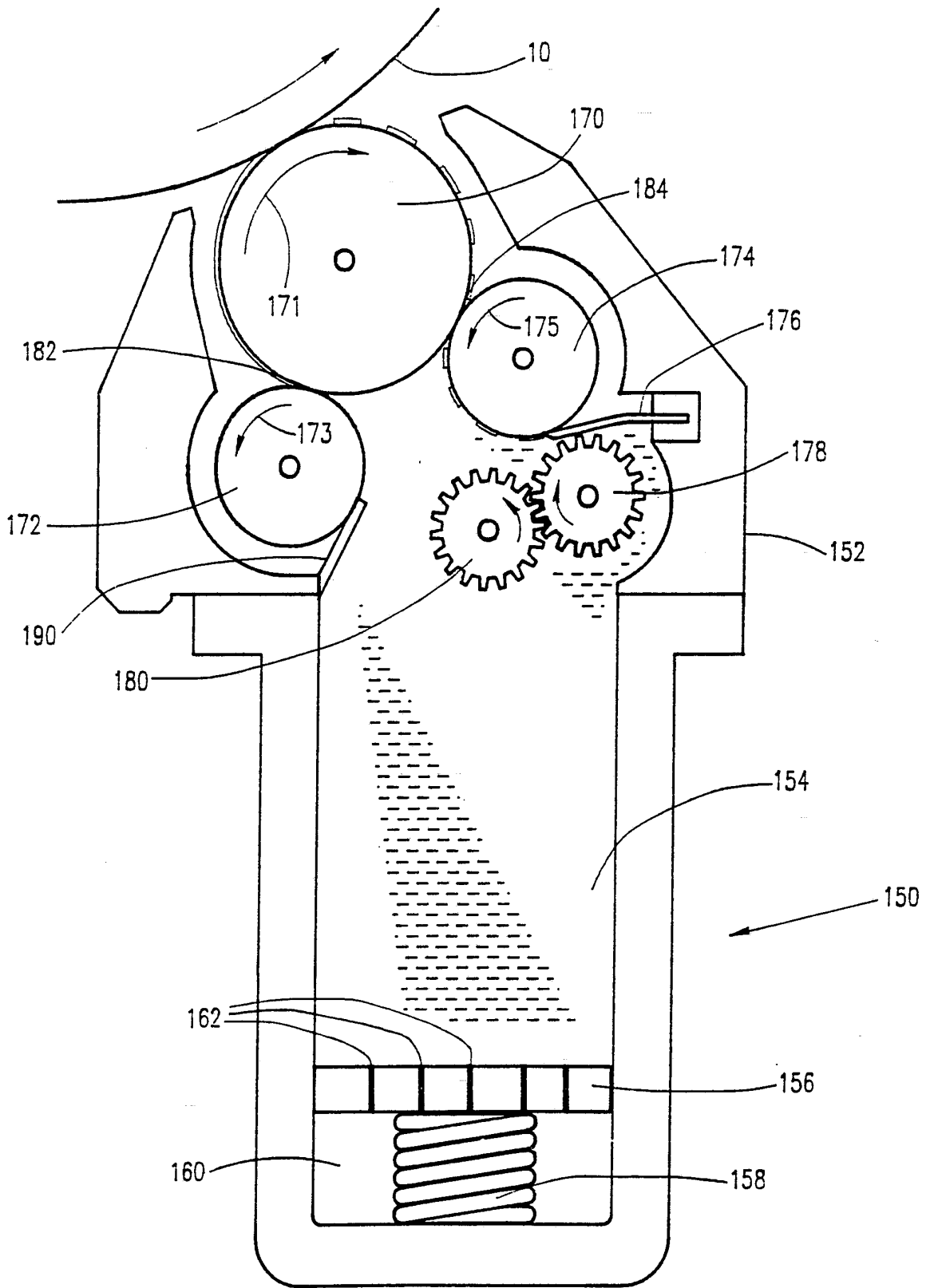

FIG. 7B

INTERNATIONAL SEARCH REPORT

International Application No **PCT/NL 91/00243**

I. CLASSIFICATION OF SUBJECT MATTER (if several classification symbols apply, indicate all) ⁶		
According to International Patent Classification (IPC) or to both National Classification and IPC		
IPC5: G 03 G 15/10		
II. FIELDS SEARCHED		
Minimum Documentation Searched ⁷		
Classification System	Classification Symbols	
IPC5	G 03 G	
Documentation Searched other than Minimum Documentation to the Extent that such Documents are Included in Fields Searched ⁸		
III. DOCUMENTS CONSIDERED TO BE RELEVANT⁹		
Category *	Citation of Document, ¹¹ with indication, where appropriate, of the relevant passages ¹²	Relevant to Claim No. ¹³
X	US, A, 4325627 (RONALD SWIDLER ET AL) 20 April 1982, see figure 4; claim 1 details 4, 20 and 35 --	1,14- 16
X	US, A, 4504138 (MANFRED R. KUEHNLE ET AL) 12 March 1985, see column 9, line 3 - line 9; figures 2,3 detail 66 --	26-29, 35,39
Y		32,33
A		1-25
E,X	EP, A2, 0481516 (SEIKO EPSON CORPORATION) 22 April 1992, see column 8, line 36 - column 9, line 25; figures 1,9 --	2,14,22, 23,25
<p>* Special categories of cited documents:¹⁰</p> <p>"A" document defining the general state of the art which is not considered to be of particular relevance</p> <p>"E" earlier document but published on or after the international filing date</p> <p>"L" document which may throw doubts on priority claim(s) or which is cited to establish the publication date of another citation or other special reason (as specified)</p> <p>"O" document referring to an oral disclosure, use, exhibition or other means</p> <p>"P" document published prior to the international filing date but later than the priority date claimed</p> <p>"T" later document published after the international filing date or priority date and not in conflict with the application but cited to understand the principle or theory underlying the invention</p> <p>"X" document of particular relevance, the claimed invention cannot be considered novel or cannot be considered to involve an inventive step</p> <p>"Y" document of particular relevance, the claimed invention cannot be considered to involve an inventive step when the document is combined with one or more other such documents, such combination being obvious to a person skilled in the art.</p> <p>"&" document member of the same patent family</p>		
IV. CERTIFICATION		
Date of the Actual Completion of the International Search	Date of Mailing of this International Search Report	
11th June 1992	30. 06. 92	
International Searching Authority	Signature of Authorized Officer	
EUROPEAN PATENT OFFICE	Marla Peis <i>Marla Peis</i>	

III. DOCUMENTS CONSIDERED TO BE RELEVANT (CONTINUED FROM THE SECOND SHEET)		
Category *	Citation of Document, with indication, where appropriate, of the relevant passages	Relevant to Claim No
X	XEROX DISCLOSURE JOURNAL, Vol. 11, No. 6, November/December 1986, Edwin Monkelbaan et al: "LEAK FREE DEVELOPER MODULE" --	27
Y	WO, A1, 9010896 (SPECTRUM SCIENCES B.V.) 20 September 1990, see page 8, line 5 - line 18; figure 2 detail 40 --	32,33
A	EP, A1, 0226750 (COULTER SYSTEMS CORPORATION) 1 July 1987, see figure 3; claim 1 --	1-25
A	US, A, 4761357 (SERGE M. TAVERNIER ET AL) 2 August 1988, see abstract; figure 1 --	1-25
A	US, A, 4833500 (MANABU MOCHIZUKI ET AL) 23 May 1989, see abstract; figure 2 --	1-25
A	US, A, 4974027 (BENZION LANDA ET AL) 27 November 1990, see column 5, line 32 - line 35; column 8, line 29 - line 60; figure 1 --	1-25
A	US, A, 3973699 (JOHN H COOK) 10 August 1976, see abstract; figure 2 --	26-39
A	US, A, 4083326 (ARTUR STANLEY KROLL ET AL) 11 April 1978, see figure 1; claim 1 -- -----	26-39

FURTHER INFORMATION CONTINUED FROM THE SECOND SHEET

V. OBSERVATIONS WHERE CERTAIN CLAIMS WERE FOUND UNSEARCHABLE ¹

This international search report has not been established in respect of certain claims under Article 17(2) (a) for the following reasons:

1. Claim numbers....., because they relate to subject matter not required to be searched by this Authority, namely:

2. Claim numbers....., because they relate to parts of the international application that do not comply with the prescribed requirements to such an extent that no meaningful international search can be carried out, specifically:

3. Claim numbers....., because they are dependent claims and are not drafted in accordance with the second and third sentences of PCT Rule 6.4(a).

VI. OBSERVATIONS WHERE UNITY OF INVENTION IS LACKING ²

This International Searching Authority found multiple inventions in this international application as follows:

~~See next page~~

1. Claims 1 - 25
2. Claims 26 - 39 For further information pls. see Form PCT/ISA/ 206 dd
31.03.1992

1. As all required additional search fees were timely paid by the applicant, this international search report covers all searchable claims of the international application.
2. As only some of the required additional search fees were timely paid by the applicant, this international search report covers only those claims of the international application for which fees were paid, specifically claims:
3. No required additional search fees were timely paid by the applicant. Consequently, this international search report is restricted to the invention first mentioned in the the claims. It is covered by claim numbers:
4. As all searchable claims could be searched without effort justifying an additional fee, the International Searching Authority did not invite payment of any additional fee.

Remark on Protest

- The additional search fees were accompanied by applicant/s protest.
- No protest accompanied the payment of additional search fees.

ANNEX TO THE INTERNATIONAL SEARCH REPORT
ON INTERNATIONAL PATENT APPLICATION NO. PCT/NL 91/00243

SA 54371

This annex lists the patent family members relating to the patent documents cited in the above-mentioned international search report. The members are as contained in the European Patent Office EDP file on 30/04/92. The European Patent office is in no way liable for these particulars which are merely given for the purpose of information.

Patent document cited in search report	Publication date	Patent family member(s)	Publication date
US-A- 4325627	20/04/82	CA-A- 1144821	19/04/83
		CH-A- 639501	15/11/83
		DE-A- 3047659	17/09/81
		FR-A-B- 2472216	26/06/81
		GB-A-B- 2065509	01/07/81
		JP-A- 56101151	13/08/81
US-A- 4504138	12/03/85	CA-A- 1192090	20/08/85
		EP-A-B- 0078018	04/05/83
		JP-A- 58100861	15/06/83
EP-A2- 0481516	22/04/92	NONE	
WO-A1- 9010896	20/09/90	EP-A- 0462172	27/12/91
		US-A- 4985732	15/01/91
EP-A1- 0226750	01/07/87	AU-B- 581790	02/03/89
		AU-D- 6434686	07/05/87
US-A- 4761357	02/08/88	EP-A-B- 0240615	14/10/87
		JP-A- 62242977	23/10/87
US-A- 4833500	23/05/89	JP-A- 61002174	08/01/86
		US-A- 4748934	07/06/88
		JP-A- 61002175	08/01/86
US-A- 4974027	27/11/90	EP-A- 0456733	21/11/91
		WO-A- 90/08984	09/08/90
US-A- 3973699	10/08/76	DE-A- 2449552	03/07/75
		GB-A- 1455885	17/11/76
		NL-A- 7414932	29/04/75
US-A- 4083326	11/04/78	NONE	

For more details about this annex : see Official Journal of the European patent Office, No. 12/82