

M. NORDEN.
ELECTRIC SIGN.

No. 568,204.

Patented Sept. 22, 1896.

Fig. 1.

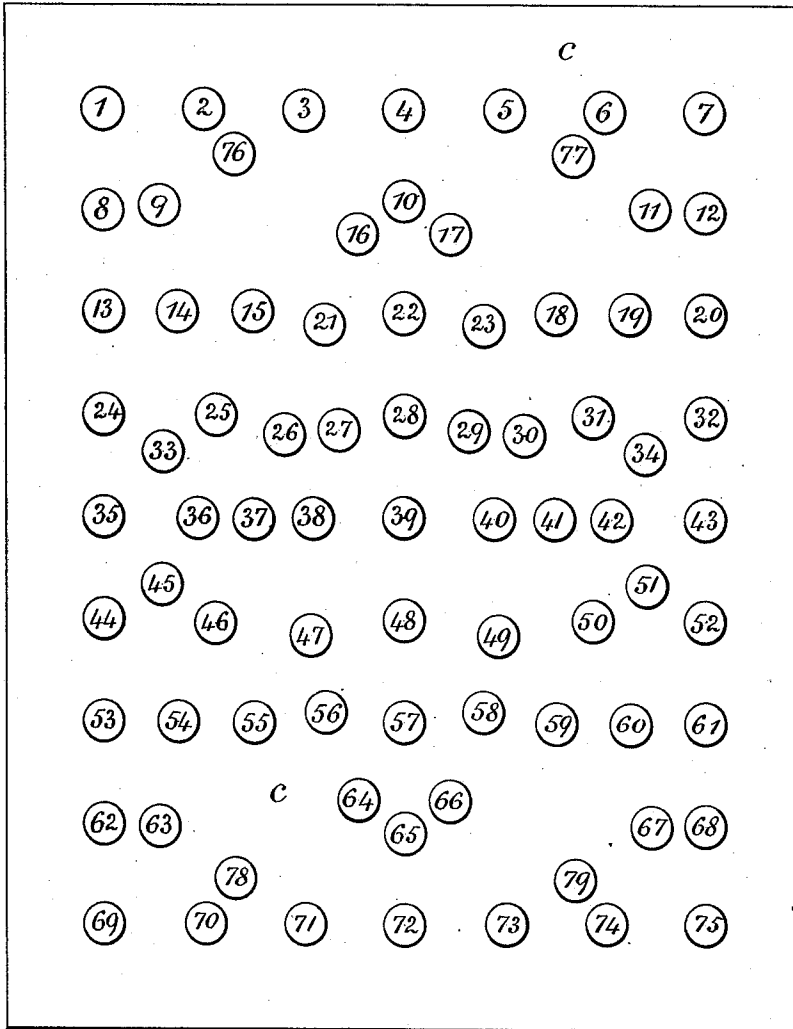

Fig. 3.

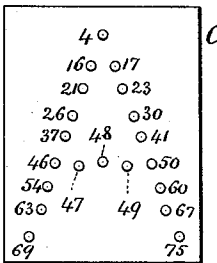

Fig. 2.

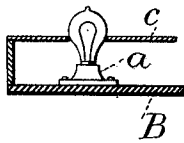
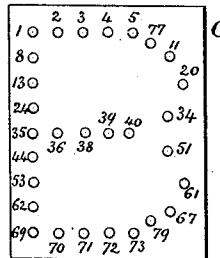

Fig. 4.



Witnesses:
J. Stair
Chas. Smith

Inventor:
Mortimer Norden
per L. W. Sevell & Son

(No Model.)

3 Sheets—Sheet 2.

M. NORDEN.
ELECTRIC SIGN.

No. 568,204.

Patented Sept. 22, 1896.

Fig. 5.

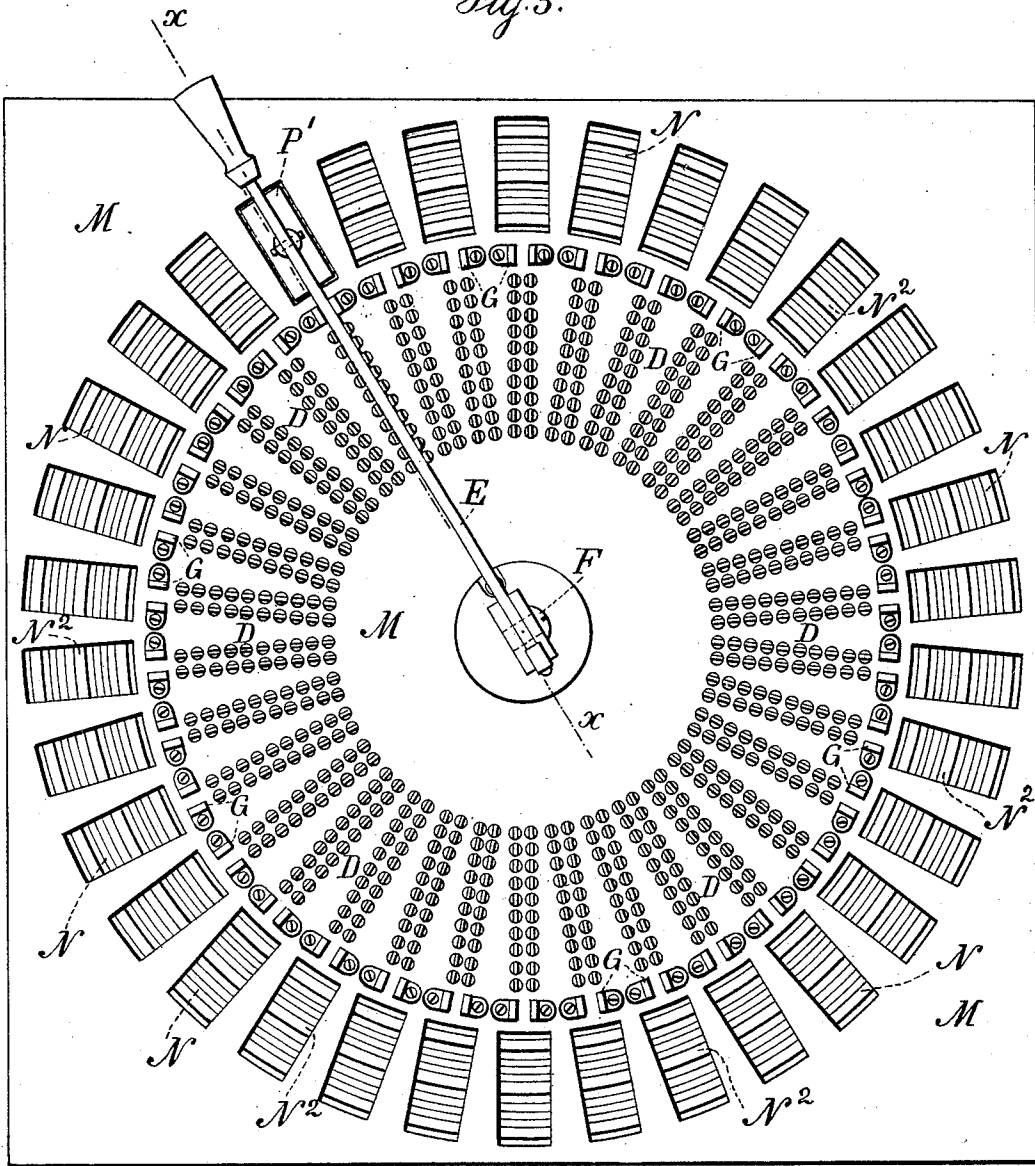

Witnesses:
J. Staib
Chas. H. Smith

Inventor:
Mortimer Norden
 per *L. W. Serrell & Son*
[Signature]

M. NORDEN.
ELECTRIC SIGN.

No. 568,204.

Patented Sept. 22, 1896.

Fig. 6.

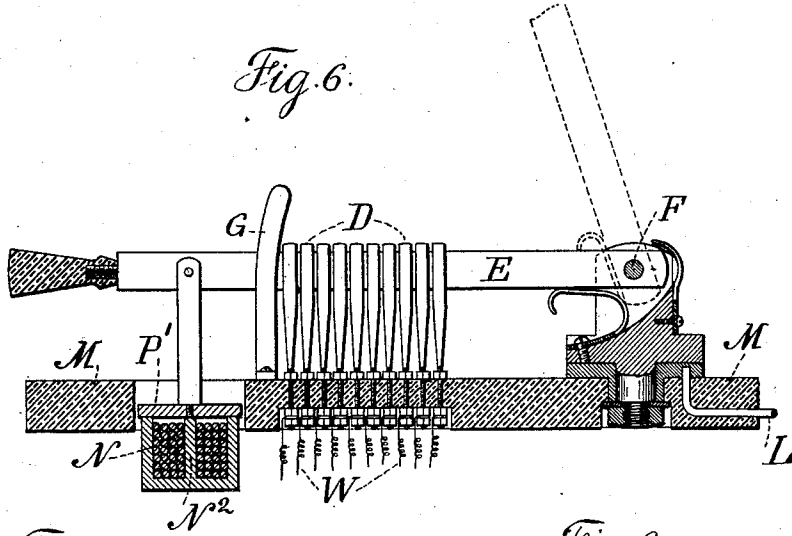

Fig. 7.

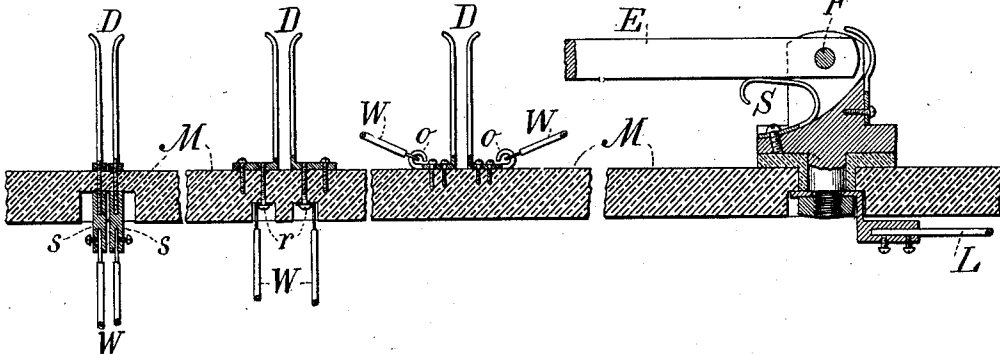

Fig. 8.

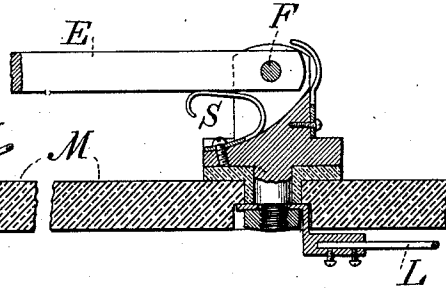
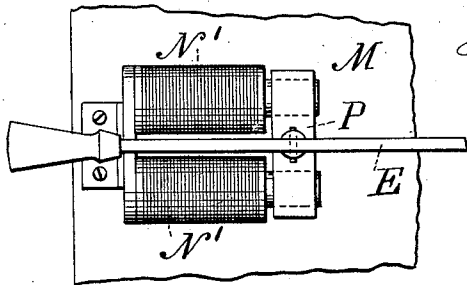

Fig. 9.



Witnesses:
J. Stair
Chas. Smith

Inventor:
Mortimer Norden
per L. W. Serrell & Son
Atty

UNITED STATES PATENT OFFICE.

MORTIMER NORDEN, OF NEW YORK, N. Y., ASSIGNOR TO MINER & CO., OF
SAME PLACE.

ELECTRIC SIGN.

SPECIFICATION forming part of Letters Patent No. 568,204, dated September 22, 1896.

Application filed February 28, 1896. Serial No. 581,120. (No model.)

To all whom it may concern:

Be it known that I, MORTIMER NORDEN, a citizen of the United States, residing at the city of New York, in the county and State of New York, have invented an Improvement in Electric Signs, of which the following is a specification.

Incandescent electric lamps have heretofore been arranged in such a way as to indicate letters or numbers when illuminated, and in some instances electric connections have been made so as to alternately illuminate and extinguish the sign or advertisement, or to effect the illumination and the extinguishment progressively.

The object of the present invention is to display different signs, words, or numbers in the same place and thus fill out a word progressively by the production of the letters in succession, or to display the desired letters or numbers to produce the words or signs at one place.

In carrying out this invention I arrange incandescent electric lamps in such relative positions as to be adapted to the production of any letter of the alphabet or any numeral, and this I term a "monogram of lamps," and one wire of an electric circuit is carried to all the lamps, and from each lamp separate wires are carried to what I term "circuit-selectors," there being as many of these to each monogram of lamps as there are letters or characters to be displayed by the monogram, and a movable contact-bar is employed with the circuit-selectors, so that when placed in one group of circuit-selectors the letter "A" will be displayed by the illumination of the lamps, and when the movable contact-bar is placed in the next group of circuit-selectors the letter "B" will be displayed, and so on, and the movable contact-bar is advantageously held in position by a retaining-magnet, and when the circuit to this is broken a spring or weight immediately disengages the contact-bar, breaking the circuit to the group of lamps. I prefer to employ an annular magnet and arrange the circuit-selectors in a circle, so as to use a movable contact that is pivoted at one end and retained in position by an annular magnet.

In the drawings, Figure 1 is a diagram representing the positions of the lamps in the monogram of lamps. Fig. 2 is a section showing the holder and septum of the monogram. Figs. 3 and 4 represent the lamps which are to be illuminated in displaying the letters "A" and "B." Fig. 5 is a plan view of the circuit-selectors and the annular magnet. Fig. 6 is a section at the line *xx*, Fig. 5. Fig. 7 are detached illustrations of different circuit-selectors. Fig. 8 is a modification of the pivot for the contact-bar, and Fig. 9 is a modification of the electromagnet for holding the contact-bar.

The monogram of letters shown in Fig. 1 is made of incandescent electric lamps of any desired character, each being attached to a base *a* upon a holder B, and it is advantageous to employ a septum *c*, having holes in corresponding positions to the bases *a*, the holes being large enough for receiving into them the incandescent electric lamps, which, of course, are movable from the bases *a*, so as to be replaced whenever required.

It will be observed that the general arrangement of the monogram of lamps consists of a quadrangle with vertical and horizontal central ranges of lamps and with other lamps interspersed so as to be adapted to the production of any letter or character desired.

The lamps are numbered in Fig. 1, and in Figs. 3 and 4 only the corresponding lamps are shown, which, when illuminated, would represent the letters "A" and "B," and the other letters and numbers will be produced by the illumination of the following lamps: "C" by lamps 12, 11, 77, 5, 4, 3, 76, 9, 13, 24, 35, 44, 53, 63, 78, 71, 72, 73, 79, 67, and 61. "D" by lamps 1, 8, 13, 24, 35, 44, 53, 62, 69, 70, 71, 72, 73, 74, 68, 61, 52, 43, 32, 20, 12, 6, 5, 4, 3, and 2. "E" by lamps 7, 6, 5, 4, 3, 2, 1, 8, 13, 24, 35, 44, 53, 62, 69, 70, 71, 72, 73, 74, 75, 36, 38, and 39. "F" by lamps 7, 6, 5, 4, 3, 2, 1, 8, 13, 24, 35, 44, 53, 62, 69, 36, 38, and 39. "G" by lamps 20, 11, 77, 5, 4, 3, 76, 9, 13, 24, 35, 44, 53, 63, 78, 71, 72, 73, 74, 67, 61, 60, and 59. "H" by lamps 1, 8, 13, 24, 35, 44, 53, 62, 69, 7, 12, 20, 32, 43, 52, 61, 68, 75, 36, 38, 39, 40, and 42. "I" by lamps 4, 10, 22, 28, 39, 48, 57, 65, and 72. "J" by lamps 4,

10, 22, 28, 39, 48, 57, 65, 71, 78, and 63. "K" by lamps 1, 8, 13, 24, 35, 44, 53, 62, 69, 54, 46, 38, 28, 23, 77, 7, 48, 58, 79, and 75. "L" by lamps 1, 8, 13, 24, 35, 44, 53, 62, 69, 70, 71, 72, 73, 74, and 75. "M" by lamps 69, 62, 53, 44, 35, 24, 13, 8, 1, 9, 14, 25, 37, 47, 56, 64, 72, 66, 58, 49, 41, 31, 19, 11, 7, 12, 20, 32, 43, 52, 61, 68, and 75. "N" by lamps 69, 62, 53, 44, 35, 24, 13, 8, 1, 9, 15, 27, 39, 49, 59, 67, 75, 68, 61, 52, 43, 32, 20, 12, and 7. "O" by lamps 4, 3, 76, 9, 13, 24, 35, 44, 53, 63, 78, 71, 72, 73, 79, 67, 61, 52, 43, 32, 20, 11, 77, and 5. "P" by lamps 69, 62, 53, 44, 35, 24, 13, 8, 1, 2, 3, 4, 5, 6, 12, 20, 32, 42, 40, 39, 38, and 36. "Q" by lamps 4, 3, 76, 9, 13, 24, 35, 44, 53, 63, 78, 71, 72, 73, 79, 67, 61, 52, 43, 32, 20, 11, 77, 5, 64, 66, 74, and 75. "R" by lamps 69, 62, 53, 44, 35, 24, 13, 8, 1, 2, 3, 4, 5, 6, 12, 20, 32, 42, 40, 39, 38, 36, 49, 60, 67, and 75. "S" by lamps 20, 11, 77, 5, 4, 3, 76, 9, 13, 24, 33, 37, 38, 39, 40, 41, 51, 52, 61, 67, 74, 73, 72, 71, 70, 62, and 53. "T" by lamps 1, 2, 3, 4, 5, 6, 7, 10, 22, 28, 39, 48, 57, 65, and 72. "U" by lamps 1, 8, 13, 24, 35, 44, 53, 63, 78, 71, 72, 73, 79, 67, 61, 52, 43, 32, 20, 12, and 7. "V" by lamps 1, 9, 14, 25, 37, 47, 56, 64, 72, 66, 58, 49, 41, 31, 19, 11, and 7. "W" by lamps 1, 8, 13, 24, 35, 44, 53, 62, 69, 63, 54, 46, 37, 26, 21, 16, 4, 17, 23, 30, 41, 50, 60, 67, 75, 68, 61, 52, 43, 32, 20, 12, and 7. "X" by lamps 1, 9, 15, 27, 39, 49, 59, 67, 75, 69, 63, 55, 47, 29, 18, 11, and 7. "Y" by lamps 1, 9, 15, 27, 39, 48, 57, 65, 72, 29, 18, 11, and 7. "Z" by lamps 1, 2, 3, 4, 5, 6, 7, 11, 18, 29, 39, 47, 55, 63, 69, 70, 71, 72, 73, 74, and 75. "1" by lamps 4, 10, 22, 28, 39, 48, 57, 65, and 72. "2" by lamps 13, 9, 76, 3, 4, 5, 77, 11, 20, 32, 42, 48, 56, 63, 69, 70, 71, 72, 73, 74, and 75. "3" by lamps 13, 9, 76, 3, 4, 5, 6, 12, 20, 31, 30, 39, 41, 51, 52, 61, 68, 74, 73, 72, 71, 78, 63, and 53. "4" by lamps 75, 68, 61, 52, 43, 32, 20, 12, 7, 6, 77, 17, 22, 26, 36, 45, 46, 47, 48, 49, and 50. "5" by lamps 6, 5, 4, 3, 2, 1, 8, 13, 24, 35, 36, 26, 28, 30, 34, 43, 52, 61, 68, 74, 73, 72, 71, 70, and 62. "6" by lamps 12, 6, 5, 4, 3, 2, 8, 13, 24, 35, 44, 53, 63, 78, 71, 72, 73, 74, 68, 61, 52, 43, 34, 29, 27, and 36. "7" by lamps 2, 3, 4, 5, 6, 7, 11, 19, 31, 41, 49, 58, 66, and 72. "8" by lamps 34, 32, 20, 11, 77, 5, 4, 3, 76, 9, 13, 24, 33, 37, 38, 39, 40, 41, 51, 52, 61, 68, 74, 73, 72, 71, 70, 62, 53, and 46. "9" by lamps 68, 74, 73, 72, 71, 70, 62, 53, 44, 35, 24, 13, 9, 76, 3, 4, 5, 77, 11, 20, 32, 42, 40, 38, 37, and 33. "0" by lamps 4, 3, 76, 9, 13, 24, 35, 44, 53, 63, 78, 71, 72, 73, 79, 67, 61, 52, 43, 32, 20, 11, 77, and 5.

The circuit-selectors are made with two springs D in the circuit and the movable contact-bar E is to be placed between the springs to close the circuit. This bar may be made in any desired manner. I, however, prefer to arrange the springs D in groups in a circle and to mount the movable contact-bar E upon a pivot F at the center of the circle, and there should be as many groups of the circuit-selectors as there are letters and numbers, and each group should be marked with its

appropriate letter or number, and the circuit connections are to be made in such a way that when the contact-bar is placed between the springs in the designated circuit-selector the corresponding lamps will be illuminated as before indicated. With this object in view I find it convenient to have one wire extending throughout the monogram of lamps to supply the electric current, and to each lamp a separate wire is connected, and from this branch wires are carried to the springs D and the return wire is connected to the pivot F and thence to the battery or other source of electric energy. I have shown in Fig. 6 the return circuit-wire L as connected with the insulated base of the pivot F, and in Fig. 8 the return circuit-wire L is represented as connected with a washer around the pivot, there being insulating material between the bottom of the pivot and the supporting board or table M.

In Fig. 6 the springs D are represented as provided with screw-threaded stems passing through the table M and provided with holding-nuts for securing them in position, and clamp-nuts for connecting the circuit-wires W, that lead to the lamps that require to be illuminated for the given letter or character.

The circuit-wires may be connected to the springs D in any desired manner. Eyes are represented at *o*, Fig. 7, for the ends of such wires and screws *r*, to which the wires may be attached, or the sockets *s* may be employed for such wires, it being understood that the wires to the respective lamps should all be covered with insulating material.

Guide-bars G may be provided on the table M to direct the contact-bar E as it is swung down between the springs D of the circuit-selectors.

It is often advantageous to hold the contact-bar electrically so that it may be swung back by a spring S to extinguish the lamps when an electric circuit is broken. With this object in view a magnet N may be provided to hold down the contact-bar E when it has been moved to position.

The magnet may be of any desired character. I have represented an ordinary magnet N' in Fig. 9, with an armature P upon the contact-bar E, which armature being brought into contact with the poles of the magnet is held in position until the circuit through the magnets is broken, when the spring S will throw up the contact-bar E. I, however, prefer to employ an annular magnet, as shown in Fig. 5, the same being formed of a circular trough of soft iron into which are introduced the energizing-coils, so that one rim of the magnet will be polarized north and the other south, and for convenience a central partition N² may be employed between the coils of the annular magnet N, and the armature P' is suitably connected to the movable contact-bar E, and when it is brought down and rests upon the rims of the annular magnet, at one place the movable contact-

bar will be held in position as long as a current flows through the helices of the annular magnet.

It will be apparent that with the foregoing instructions an electrician will take each group of circuit-selectors in succession and connect from the springs of the selectors wires to the lamps required for the given letter or character and proceed until the selectors are all properly connected, so that any desired letter, figure, or character can be produced upon the monogram of lamps by introducing the movable contact between the springs of the designated circuit-selector.

Where but one monogram of lamps is employed, words or numbers can be spelled out by the successive illumination of the proper characters, but where a sign is made up of a number of monograms of lamps there should be for each monogram of letters a complete set of devices, as shown in Figs. 5 and 6. Hence the proper letters and numbers can be displayed in succession along upon the sign by placing the contact-bars E in the proper positions for the successive monogram of lamps, and if the current is turned on the letters or characters will be illuminated in succession as the contact-bars are put into position, or the contact-bars can be put in position and the current turned on to illuminate all the letters of the sign simultaneously, and the entire sign can be extinguished by turning off the current, and the contact-bars can be liberated by breaking the circuit to the retaining-magnets.

The circuit-selectors may be arranged in any desired manner, as it is not necessary to have them in a circle, and their position may be varied according to the convenience of the operator.

It will be apparent that the circuit-selectors being in two ranges, one at each side of the contact-bar, and one of the circuit-wires being connected with the contact-bar, the circuits to the lamps are closed by the insertion of the contact-bar between the two ranges and the sliding motion of the contact-bar upon the surfaces of the selector-springs insures perfect electric contact.

I claim as my invention—

1. The combination with a monogram of incandescent electric lamps and circuit-wires to

the same, of groups of insulated circuit-selecting springs in pairs to which the conductors are connected, such groups being arranged radially, and a contact-bar pivoted at the center of the groups for closing the circuits to the lamps in the monogram for either sign or letter to be illuminated, substantially as set forth.

2. The combination with a monogram of incandescent electric lamps and circuit-wires to the same, of groups of insulated circuit-selecting springs in pairs to which the conductors are connected, such groups being arranged radially, and a contact-bar pivoted at the center of the groups for closing the circuits to the lamps in the monogram for either sign or letter to be illuminated, and a ring-shaped electromagnet around the circuit-selectors, and an armature on the contact-lever for holding such lever in position until the circuit to the electromagnet is broken, substantially as specified.

3. The combination with a monogram of incandescent electric lamps and circuit-wires to the same, of groups of insulated circuit-selecting springs in pairs to which the conductors are connected, such groups being arranged radially, and a contact-bar pivoted at the center of the groups for closing the circuits to the lamps in the monogram for either sign or letter to be illuminated, and an electromagnet and an armature near the outer end of the contact-bar for holding the same in position while the circuits to the lamps are closed, substantially as specified.

4. The combination with a monogram of incandescent electric lamps and the circuit connections to the same, of groups of insulated circuit-selecting springs in pairs and to which the lamp-wires are connected, such groups being arranged radially and a contact-bar pivoted at the center of the group and a conductor connected with the pivot whereby the lamps in the monogram that form the sign or letter are brought into action by the contact-bar between the groups of springs, substantially as set forth.

Signed by me this 17th day of February, 1896.

MORTIMER NORDEN.

Witnesses:

C. L. HAMMOND,
GEO. T. PINCKNEY.