



Europäisches Patentamt
European Patent Office
Office européen des brevets



Publication number:

0 411 560 A2

12

EUROPEAN PATENT APPLICATION

21 Application number: 90114666.2

51 Int. Cl.⁵: **E02D 19/16, E02D 19/18,
E02D 3/00, E02D 3/12**

22 Date of filing: 31.07.90

30 Priority: 03.08.89 IT 359289
08.05.90 IT 348890

43 Date of publication of application:
06.02.91 Bulletin 91/06

84 Designated Contracting States:
DE ES FR GB

71 Applicant: **TREVI S.p.A.**
Via Dismano 5819
I-47023 Cesena (Province of Forli)(IT)

72 Inventor: **Botto, Giuseppe**
P.zza Ardigò, 30
I-00142 Roma(IT)
Inventor: **Trevisani, Davide**
Via Pascoli 680
I-47023 Cesena (Forli)(IT)

74 Representative: **Modiano, Guido et al**
MODIANO, JOSIF, PISANTY & STAUB
Modiano & Associati Via Meravigli, 16 16 16
I-20123 Milano(IT)

54 **Apparatus for consolidating soil.**

57 The apparatus for consolidating soil comprises a mixing-disaggregation tool (15, 113) which is applied to the lower end of a vertical rotating shaft (7, 108) which, after being placed at a point of the region of the soil to be consolidated, is caused to advance into the soil with the simultaneous introduction of air and, if necessary, of water. Once the required depth has been reached, a consolidating agent is introduced in the soil through appropriate holes (19, 24, 183) defined proximate to the disaggregation-mixing tool (15, 113) while the lifting of the tools is simultaneously performed.

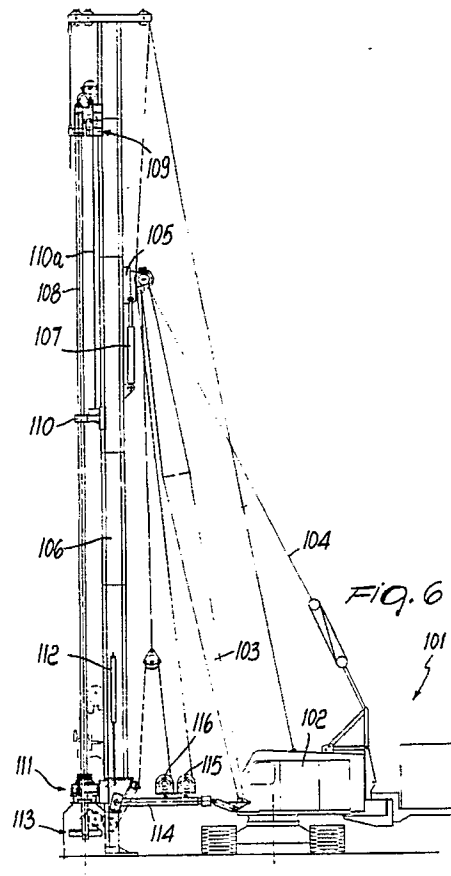

EP 0 411 560 A2

APPARATUS FOR CONSOLIDATING SOIL

The present invention relates to an apparatus for consolidating predominantly cohesive, soft and dry soil.

Current known techniques include the method of onsite mechanical mixing by addition of a consolidating mixture based on water and a consolidating agent, which allows to increase the resistance of soil, by means of forced mixing with the soil which has been disaggregated beforehand by a special rotary tool, consequent to the hydration reaction which occurs between the consolidating agent and the argillaceous or clayey part of the soil. This method is applicable in the case of predominantly cohesive soil, since the argillaceous component is capable of performing the hydration reaction with the introduced agent.

This consolidation method has the substantial disadvantage that a large amount of water is required for preparing the binary mixture and for setting with the soil on-site.

The excess water which derives from the reactions of the mixture with the soil remains present in the soil in the form of free water which compromises the final general resistance characteristics of the soil to be consolidated.

The aim of the present invention is therefore to obviate the described disadvantages by providing an apparatus for consolidating soil which allows to overcome such limitations imposed by the method hitherto used, due to its way of operating with the disaggregation tool, providing consolidations in predominantly cohesive, soft, dry soil or in soil which has dry intercalated layers or in cohesive soil in which the surface crust is insufficiently humidified to ensure hydration.

A further object of the invention is to provide an apparatus for performing the consolidating process which allows to introduce the consolidating agent and the amount of water required for hydration.

This aim and this object are achieved, according to the present invention, by an apparatus which comprises a unit for storing a consolidating agent and a water tank, characterized in that it comprises a shaft which is slidably supported by a vertical tower, said shaft being formed by a plurality of tubular sections which are mutually longitudinally connected so as to define a duct for the water and a duct, separated from the first one, for the consolidating agent, said ducts extending down to the lower end of said shaft, where a disaggregating tool is mounted, said tool comprising radial blades provided with excavation teeth, holes being defined on said shaft proximate to said blades, said holes being connected to said ducts for introducing water

and consolidating agent into the soil, said ducts being fed from the top of the shaft through tubes which are connected to the water tank and to the storage unit formed by a silo for the consolidating agent and an air compressor.

Further characteristics and advantages of the invention will become apparent from the non-limitative description of the process, illustrated with the aid of the accompanying drawings, wherein:

- 5 figure 1 is a schematic view of an apparatus for performing the process;
- figure 2 is a partially sectional lateral elevation view of a detail of the apparatus;
- figure 3 is a frontal elevation view of the disaggregation tool;
- 10 figure 4 is a plan view of a detail of the disaggregation tool;
- figure 5 is a partial sectional view of the tool taken along the section line V-V of figure 4;
- 15 figure 6 is a schematic view of an apparatus according to a varied embodiment of the invention;
- figure 7 is a partially sectional frontal elevation view of the top of the shaft of the apparatus of figure 6;
- 20 figure 8 is a partially sectional view of an intermediate section of the shaft of the apparatus of figure 6;
- figure 9 is a sectional view of the shaft section taken along the section line IX-IX of figure 8;
- 25 figure 10 is a frontal elevation view of the element for the rotary motorization of the shaft;
- figure 11 is a partially sectional view taken along the section line XI-XI of figure 10;
- 30 figure 12 is a lateral elevation view of the disaggregation-mixing tool;
- figure 13 is a partial sectional view of the disaggregation-mixing tool taken along the section line XIII-XIII of figure 12;
- 35 figure 14 is a partially sectional view, taken along the section line XIV-XIV of figure 12, and figure 15 is a perspective view of the means which allow the penetration of the disaggregation-mixing tool into the soil and the lifting of said tool out of said soil.

With reference to figures 1-5, the apparatus is generally indicated by the reference numeral 1 and comprises a self-propelled tracked vehicle 2 provided with a control and operation cabin in which an operator is accommodated. An arm 3 is frontally mounted on the vehicle 2, is supported by tension elements 4 and supports a tower 5. The vertical elevation of the tower 5 is controlled by arms 6 which connect its lower end to the vehicle 2.

A shaft 7 is slidably and rotatably supported on

the tower 5; during the operating steps, said shaft is actuated by means of a motorization unit 8 which is slidable along the tower 5. The shaft 7 is composed of a plurality of individual tubular sections 9 which are mutually connected longitudinally. The sections, as can be seen in figure 2, are composed of an outer tube 10 inside which an inner tube 11 is arranged coaxially. The ends of the section 9 are shaped so as to constitute couplings 11a, 11b which allow the axial connection of various sections.

The tubes 10, 11 thus define an outer duct 12 and an inner duct 13 which are mutually separated.

A disaggregation-mixing tool, generally indicated by the reference numeral 15 in figure 3, is rigidly associated with the lower end of the shaft 7 by means of a coupling 14. The disaggregation tool comprises a pair of diametrically opposite lower blades 16 and a tubular element 17, which constitutes the central part of said tool and has a cutting head 17a at its lower end.

The blades 16 are tile-shaped and teeth 18, suitable for excavating and moving the soil, are rigidly associated with their lower edge. Said teeth are arranged tangentially with respect to the axis of rotation of the shaft 7. Holes 19 are defined below the blades 16 and are connected to the inner duct 13, whereas holes 20 are defined above the blades and are connected to the outer duct 12.

A pair of radial wings 21 is fixed on the element 17 above the blades 16, and their function is to keep the soil under agitation during the perforation step, as will become apparent hereinafter.

A further pair of blades 22 is arranged above the wings 21. Said upper blades have the same structure as the blades 16, and holes 23, 24, respectively connected to the ducts 12, 13, are defined above and below them.

The inner duct 13 of the shaft 7 is fed from above, through the external tube 25, with the consolidating agent, in particular pulverized cement, by the unit 26 which is formed by a cement silo 27 and by an air compressor 28. The outer duct 12 of the shaft 7 is fed, in an upward position, with water through the tube 29. The water is drawn from a storage tank 30 by means of a pump 31 which sends the excess water of the hydration process back to the tank by means of a return tube 32.

The described apparatus operates in the following manner.

In a first step, the disaggregation tool is placed on the region of the soil to be treated and the verticality of the tower is checked.

Then perforation of the soil begins with the preset rotation and advancement parameters, rotating the tool 15 with a rotation and advancement rate which is a function of the consistency of the soil. While the tool 15 penetrates into the soil, the

compressor 28 initially sends air through the tube 25 and the duct 13. The air enters the soil through the holes 19 and 24, facilitating the penetration of the tool and keeping the duct 13 free.

During the penetration of the tool in the soil, water is sent through the tube 29 and the duct 12 only when dry or very hard layers, which prevent the normal advancement of the tool, are encountered.

The amount of pumped water must be such as to provide the necessary humidification of the dry layers being traversed and thus allow the subsequent hydration of the consolidating agent.

Once the required depth has been reached, while the tool continues to rotate, the feeding of the consolidating agent starts; said agent passes through the tube 25 and the inner duct 13 and enters the soil through the holes 19 and 24.

Then the lifting of the tool begins, reversing the direction of rotation. In this manner the humidified soil is mixed with the pulverized cement, so that preset speed parameters, as a function of existing stoichiometric ratios, are respected in the lifting step as well.

The advantage of this process is that the amount of water used reacts entirely with the consolidating agent and therefore greater stability is given to the treated soil by leaving no free water in the soil or on the surface.

In the varied embodiment of the invention illustrated in figures 6 to 15, the reference numerals start from 101 to indicate a self-propelled tracked vehicle provided with a control and operation cabin 102 in which the operator is accommodated.

An arm 103 is articulately mounted frontally to the vehicle 101 and is supported by tension elements 104. A slider 105 is mounted at the top of the arm 103 and slidably supports a tower 106. The tower rests on the ground and is suspended from the slider 105 by means of a hydraulic jack 107. By inclining the arm 103 by means of the tension elements 104 it is possible to position the tower 106 with respect to the vehicle 101, whereas by actuating the jack 107 it is possible to raise and lower the tower to allow the vehicle to move to a new work site or to allow the spacing of the tower with respect to the vehicle when the arm 103 is inclined outward. A shaft, generally indicated by the reference numeral 108, extends frontally to the tower, i.e. on the opposite side with respect to the slider 105, and is rotatably suspended, with its upper end, from a ledge 109 which is guided on the tower 106.

The shaft 108 is guided, in a median position, within a guiding element 110 which is suspended from the ledge 109 by means of a cable (or chain) 110a and is also guided along the tower 106. The

shaft 108 is rotationally coupled, in a downward position, to a rotary motorization element 111 which can be raised and lowered by a certain extent by means of a pair of jacks 112 mounted to the sides of the tower 106.

The disaggregation-mixing tool, generally indicated by the reference numeral 113, is applied to the lower end of the shaft 108 below the motorization element 111. The motorization element is guided along the tower 106 and is connected to the vehicle by a bridge 114 on which two winches 115, 116 are located; said winches, by means of a double cable system, raise or lower the ledge 109 with a closed-loop and synchronized traction and therefore raise or lower the shaft 108.

More in detail (see figure 7), the ledge 109 is constituted by a plate 117 which is traversed by a sleeve 118 which is rigidly associated with the plate 117 by ribs 119. A sleeve 120 is arranged coaxially inside the sleeve 118 and is rotatably supported by means of a pair of thrust bearings 121, 122. The upper bearing 121 is retained between an internal shoulder of the sleeve 118 and a pair of rings 123 which are screwed on a threaded portion of the sleeve 120.

A cylindrical body 125 is centered on the top of the sleeve 118 and has a flange 126 which is traversed by bolts 127 which engage in a collar 128 of the sleeve for the mechanical coupling of the two parts 125, 118.

The cylindrical body 125 has a lower seat 129 in which the tapered end portion 131 of the sleeve 120 sealingly rotates by virtue of the interposition of a gasket 130. The sleeve 120 has, in a downward position, a flange 132 which defines the seat for the bearing 122 and extends externally to the sleeve 118. A disk 133 is centered on the flange 132 and centrally comprises a tube 134 which rises coaxially inside the sleeve 120 and delimits therewith an annular chamber or interspace 135.

The flange 136 of a male element 137 of a coupling of the shaft 108 is associated with the disk 133 in a downward position. The disk 133 is secured between the flanges 132 and 136 by bolts 138. Rubber rings 139, 140 ensure the necessary outward seal. A cavity 141 is defined in the disk 133 and is connected, through passages 142, to the annular chamber 135. A channel 143 extends from the cavity 141 and, by means of a connection 144 fitted in the flange 136, leads outward so as to connect to a duct 165 which is specified hereinafter.

The tube 134 extends upward beyond the tapered portion 131 of the sleeve 120 with a reduced-diameter portion 145 which sealingly rotates in two seats 146 and 147 of the cylindrical body 125 which are termed respectively intermediate seat and upper seat.

Sealing gaskets 148, 149 are interposed between the outer surface of the portion 145 and the seats 146, 147, whereas openings 150 are defined between the seats 146, 147 in the wall of the cylindrical body and directly connect to the outside the annular chamber comprised between the gaskets 148, 149 and the opposite walls of the cylinder 125 and of the portion 145 of the tube 134.

The tube 134 is connected to a supply of compressed air and to a supply of a consolidating agent (for example cement) by means of a stationary tube 151 which has a flange 152 bolted on the head of the cylindrical body 125. The seal between the tube 151 and the rotatable tube 134 is ensured by a gasket 153 which is interposed between the opposite ends of the tube 151 and of the portion 145.

The annular chamber 135 is connected to a water supply through a hole 154 defined radially in the body 125 between the lower seat 130 and the intermediate seat 146.

The shaft 108, which is to be connected to the male element 137, is constituted by a plurality of tubular sections 155, one of which is shown in figures 8 and 9. Said section comprises an external tube 156 which has a square cross section with rounded corners; a female element 157, shaped complementarily with respect to the male element 137, is inserted at the top of said tube 156.

For this purpose, the female element 157 has a cavity in which a cylindrical seat 158 is defined for accommodating a cylindrical portion 159 of the male element 137 and a square seat 160 for receiving the square portion 161 of the male element 137. Whereas a prismatic coupling is defined between the seat 160 and the portion 161 and allows the rotary coupling between the section 155 and the element 137, a hydraulic coupling is defined between the seat 158 and the portion 159 and is sealed by sealing rings 162.

In order to prevent the axial extraction of the section 155, semi-cylindrical grooves 163, 164 are defined in the inner and outer opposite walls of the seat 160 and respectively of the portion 161; when the elements 157 and 137 are inserted in one another, said grooves form holes for the accommodation of lugs which act as keys. A duct 165 is welded externally to the tube 156 along a median line of a face and extends substantially along the entire length of the section 155. The duct 165 is connected to the union 144 in an upward position with the addition of a sleeve 166, and is connected to the duct 165 of the subsequent sections in a downward position by means of further sleeves 167.

A cylindrical tube 168 is arranged in tangential contact inside the square tube 156, and a further coaxial tube 169 is arranged inside it. Said tube

169 is centered, in an upward position, in a bush 170 which is inserted in the female element 157 and is centered, in a downward position, in a bush 171 which is inserted in a male element 172 which closes the section 155 downward. The bushes 170, 171 are axially locked by Seeger rings 170a and 171a and are sealingly coupled in the respective seats by rubber rings 170b and 171b.

The male element 172 is fully similar to the male element 137 described above and is therefore shaped so as to mechanically and hydraulically couple to a successive female element.

The disaggregation-mixing tool 113 is associated with the end of the last of the sections 155 which compose the shaft 108 and comprises a tubular element which is provided, in an upward position, with a female coupling element 173 (see figures 12-14) suitable for coupling to a male element 172. A sleeve 174 is rigidly associated with the element 173 and extends downward with a cylindrical jacket 175 in which a further sleeve 176 is centered. A cylindrical shaft 177 is inserted in the sleeves 174 and 176, and the cutting head 178 is fixed to the lower end of said shaft. The shaft 177 is keyed in the sleeve 176 by a through pin 179, whereas it defines, at the top, a cylindrical cup 180 which is open toward the cavity 181 of the element 173, with which it is connected by means of a bush 180a. The bush 180a is retained by a Seeger ring 180b and is sealingly inserted in its seat by means of rubber rings 180c, so that when the male element 172 of the overlying section 155 is inserted in the cavity 182 a connection with the tube 169 is provided. Two radial holes 182 extend from the cup 180 and traverse the wall of the sleeve 174; respective nozzles 183 are inserted in said holes.

A pair of blades 184 is welded to the sleeve 174; said blades are arranged diametrically and are inclined forward and downward with respect to a counterclockwise direction of rotation. A plurality of disaggregation teeth 185 is welded on the front edge of the blades 184, and respective wings 186 are welded on the rear edge and delimit a cavity 187 which is open downward and at which the nozzles 183 are located. A similar pair of blades 188 with teeth 189 is welded diametrically to the sleeve 176 but is angularly offset by 90 degrees with respect to the blades 184, so that the blades 184 and 188 form a cross in plan view.

When the section 155 is inserted in the cavity 181, the duct 165 is connected through a sleeve 167 to a tubular element 190 which is rigidly associated externally to the element 173 and ends with a nozzle 191 which is directed downward and is located at the level of the pair of upper blades 184.

The motorization or propulsion element 111 (see figure 10) comprises a slider 192 which is

guided along the tower 106 and is movable by means of jacks 112. An annular ledge 193 is protrudingly mounted on the slider 192 and a motor unit 194, which is axially traversed by the shaft 108, is applied thereto in an upward position.

The motor unit 194, which is not illustrated in detail since it is of a conventional hydraulically-operated type, comprises a traction block 195 which axially guides and exerts a traction on the shaft 108. The traction block 195 is composed of a fifth wheel 196 (see figure 11) on which pairs of wings 197 are welded at the faces of the tube 156.

Each pair of wings 197 rotatably supports, by means of the interposition of bearings, a roller 198 which is slightly cambered at the center.

The roller 198, which is opposite to the duct 165, has a median groove 199 which allows the passage of said duct. A dome 200 is rigidly associated with the ledge 193 in a downward position and encloses the disaggregation-mixing tool 113, with respect to which it can be raised and lowered when the slider 192 is actuated by the jack 112.

The top of the dome 200 is constituted by a plate 201 which defines a cylindrical seat 202 for the rotatable accommodation of two rings 203 which circumscribe the tube 156 with a prismatic engagement. The rings 203 have the function of scraping any material which adheres to the walls of the shaft 108 when said shaft is caused to slide through the motorization unit 111.

A double cable system is provided for the lifting and lowering of the shaft 108 and can be actuated, as mentioned, by means of two winches 115, 116 which are mounted on the bridge 114. The winch 116 (see figure 15) acts on a cable 204 which is wrapped around a plurality of pulleys 205-210 and has its end connected to the tower 106. The pulley 205 is rotatably supported on the slider 105, whereas the pulleys 206-208 are mounted at the top of the tower 106 and form a tackle with the pulleys 209-210 which are mounted on the ledge 109. The winch 115 acts on the cable 211, the end whereof is connected to the base of the tower. The cable 211 is wrapped around a pair of transmission pulleys 212, 213 and around two pairs of pulleys 214-217. The pulleys 212, 213 are supported respectively on the slider 105 and at the lower end of the tower 106. The pair of pulleys 214, 215 is mounted under the ledge 109 and forms a further tackle together with the pair of pulleys 216, 217 which is mounted at the lower end of the tower 106.

The described apparatus operates in the same manner as the preceding one, the only difference being that the compressed air, the humidification water and the consolidating agent are injected into the soil during the perforation and the rise of the tool, through the same nozzles 183.

A considerable advantage of the apparatus of figures 6-15 is the fact that the ducts for the water and air and for the consolidating agent remain constantly separated, so that there is no possibility of mixing the two flows. If wear should occur at the seals 148, 149, the bled fluid (water or air or consolidating agent) can flow directly outward through the openings 150 of the cylindrical body 125 and be detected by the assigned personnel.

The structure of the sections 155 and of the rotatable coupling, by means of which the ducts for water, air and consolidating agent are connected to stationary ducts, is particularly important. The inner ducts 169 and 134, in case of wear, can in fact be easily replaced, since it is sufficient, for this purpose, to remove the disk 133 or the ring 171b in order to extract the tubes 134 or 169. It is similarly possible to remove cloggings in the region of the nozzles 183 by removing the pin 179 and then extracting the cylindrical shaft 177 from below.

A further advantage of the present invention is constituted by the dome 200, by virtue of which it is possible to prevent the dust produced when the disaggregation-mixing tool approaches the surface of the soil during its upward stroke from being scattered around with considerable disadvantages from the point of view of environmental impact. It should be noted that the dome can be raised by means of the jacks 112 to allow, if required, inspection of the disaggregation-mixing tool 113.

Further modifications and variations are possible in the practical embodiment of the invention.

One of them provides, for the tube 156, a non-square cross section, for example a triangular or hexagonal or even circular one with outer longitudinal strips acting as keys. In a further embodiment, the duct 165 is located inside the tube 156 at the chambers defined between the inner tube 168 and the tube 156.

In the practical embodiment of the invention, it is possible to provide the duplication of the shafts 108 and of the tools 113 so as to simultaneously produce two columns of consolidated soil.

Where technical features mentioned in any claim are followed by reference signs, those reference signs have been included for the sole purpose of increasing the intelligibility of the claims and accordingly such reference signs do not have any limiting effect on the scope of each element identified by way of example by such reference signs.

Claims

1. Apparatus for consolidating soil, comprising a unit for storing a consolidating agent and a water tank, characterized in that it comprises a shaft

(7;108) which is slidably supported by a vertical tower (5;106), said shaft being formed by a plurality of tubular sections (9;155) which are mutually connected longitudinally so as to define a duct (12;165) for the water and a duct (13;169), separate from the first duct, for the consolidating agent, said ducts extending down to the lower end of the shaft, where a disaggregation-mixing tool (15;113) is mounted, said tool comprising lower radial blades (16;22;184,188) provided with excavation teeth (18;185,189), holes being defined on said shaft (108) proximate to said blades, said holes being connected to said ducts (19,20,24;183) so as to introduce into the soil water and a consolidating agent, said ducts being fed from the top of the shaft through tubes which are connected to the water tank (30) and to the storage unit (26) formed by a silo (27) for the consolidating agent and an air compressor (28).

2. Apparatus according to claim 1, characterized in that it comprises a substantially vertical tower (106) which supports a shaft (108) which is composed of a plurality of sections (155) which are mutually longitudinally connected, each section being composed of a tube (169) for the conveyance of compressed air and of a consolidating agent, said tube being arranged coaxially inside a polygonal tube (156), a duct (165) for the conveyance of water being associated in a hydraulically separate manner with said tube (156), said shaft having an upper end which is rotatably supported in a ledge (109) which is guided along said tower and has rotatable couplings (130,148,149,153) for connection to a supply of compressed air and of consolidating agent, as well as of water, said shaft being coupled with a rotary motorization element (111) in a downward position in a manner which is rotationally rigid but axially slidable.

3. Apparatus according to claim 2, characterized in that each of said sections (155) comprises an outer tube (156) which has a polygonal cross section and at the top of which the female element (157) of a coupling is inserted, said coupling having a cylindrical seat (158) and a polygonal seat (160) for receiving the cylindrical and respectively polygonal portion (159,161) of the male element of a contiguous section, a cylindrical tube (168) being in tangential contact inside said polygonal tube (156), a further tube (169) being arranged coaxially in said cylindrical tube (168), said further tube (169) being centered in rings (171,170) which are inserted in said male and female elements (172,157), a duct (165) being externally rigidly associated with said polygonal tube (156) and extending along the median line of one of the faces.

4. Apparatus according to claim 2, characterized in that a sleeve (118) is fixed on the ledge (109) for the rotatable support of the shaft and a further

sleeve (120) is coaxially arranged inside said sleeve (118) and is rotatably supported by means of thrust bearings (121,122), a cylindrical body (125) being centered and fixed to the top of said sleeve (118), said cylindrical body defining a lower seat (129) in which the top of said further sleeve (120) sealingly rotates, an intermediate seat (146) and an upper seat (147) in which the end portion of a tube (134) sealingly rotates, said tube (134) being connected to the air and consolidating-agent supply, arranged coaxially to said sleeve (120) and rigidly associated with a coupling disk (133) for a male element (137) of said coupling, an annular chamber (135) being defined between said further sleeve (120) and said tube (134), said chamber being connected to the water supply on one side and to said outer duct (165) on the other side, openings (150) being provided and arranged between said intermediate seat (146) and said upper seat (147) and being directly connected to the outside.

5. Apparatus according to claim 3, characterized in that said motorization element (111) comprises a traction block (195) which is composed of a fifth wheel (196) which circumscribes said shaft (108), pairs of wings (197) being welded on said fifth wheel at the faces of said polygonal tube (156), each of said wings supporting a roller (198) which engages tangentially on the respective face of said polygonal tube, one of said rollers having an annular groove (199) to allow the passage of said outer duct (165).

6. Apparatus according to claim 5, characterized in that said rollers (198) are cambered.

7. Apparatus according to claim 5, characterized in that said traction block element comprises a plate (201) which defines a cylindrical seat (202) for the rotatable accommodation of scraper rings (203) which circumscribe said shaft (108) with a prism-like engagement.

8. Apparatus according to claim 1, characterized in that said disaggregation-mixing tool (15, 113) comprises a tubular element (17, 174, 175, 176) which has, at the top, an element (14;173) for coupling to the shaft (7, 108) and is externally provided with two pairs of longitudinally offset disaggregation blades (16,22;184,188), a cutting head (17a;178) being fixed in a downward position to said tubular element (17, 174, 175, 176).

9. Apparatus according to claim 8, characterized in that said head (178) is rigidly associated, in a downward position, with a shaft (177) which is keyed internally to said tubular element (174, 175, 176) and defines, in an upward position, a cup (180) which is connected to the inner tube (169) of said sections (155) and has holes (182) which are connected to the outside by means of nozzles (183) located below the pair of upper blades (184).

10. Apparatus according to claim 9, characterized in that said blades (184) define, in a downward position, cavities (187) which are open downward and at which said nozzles (183) are located.

11. Apparatus according to claim 2, characterized in that said ledge (109) for supporting the shaft (108) can be raised and lowered by means of a double system of cables (204,211) which can be actuated by means of a pair of winches (116,115), said cables forming two respective tackles which have one end fixed to the tower (106) and the opposite end fixed to said ledge (109).

12. Apparatus according to claim 2, characterized in that a dome (200) is rigidly associated, in a downward position, with said motorization element (111), said dome being superimposable on said disaggregation-mixing tool (113), said motorization element (111) being mounted on a ledge (193) and slider (192) which is guided along said tower (106) and is movable by means of fluid-actuated jacks (112) between a lowered position for covering said tool (113) and resting on the ground and a raised position suitable for allowing inspection of said tool.

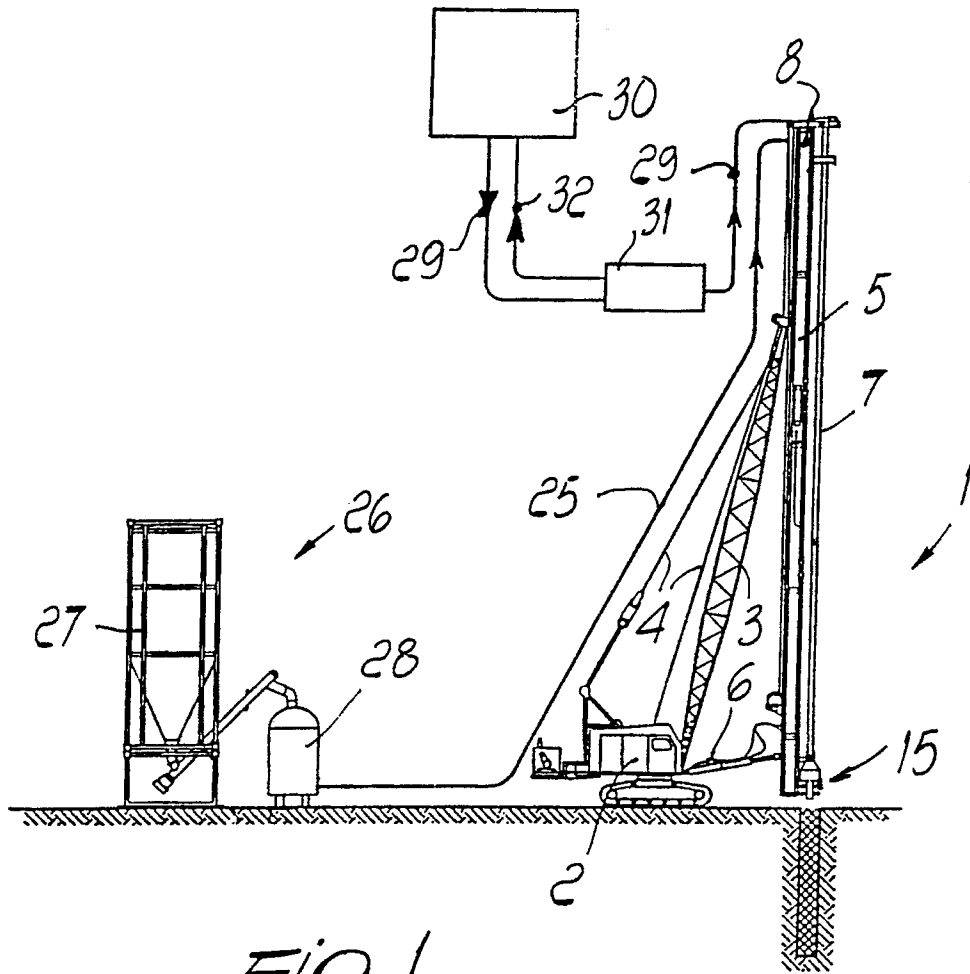

Fig. 1

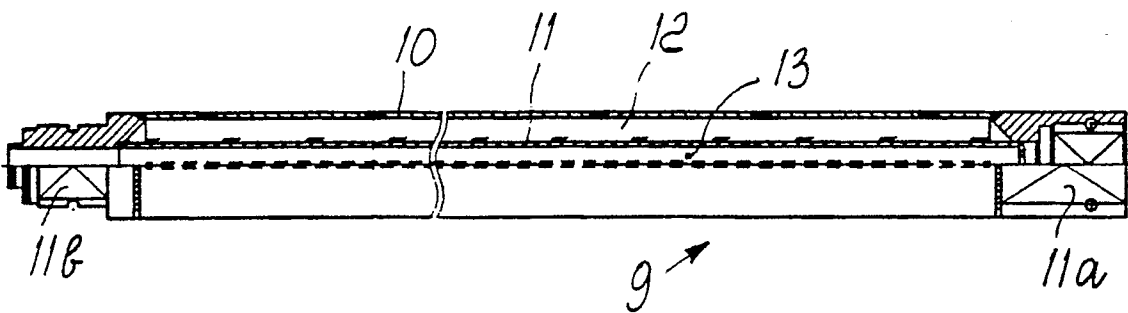
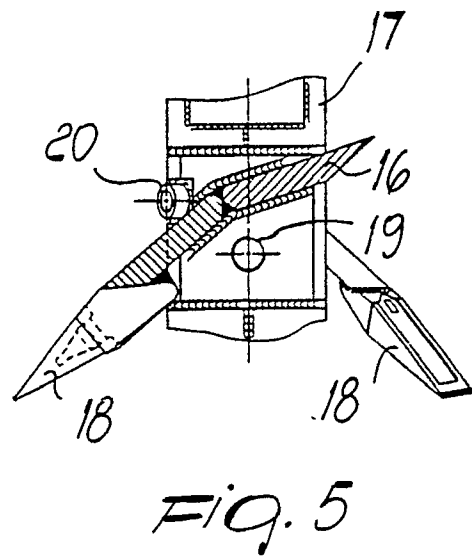
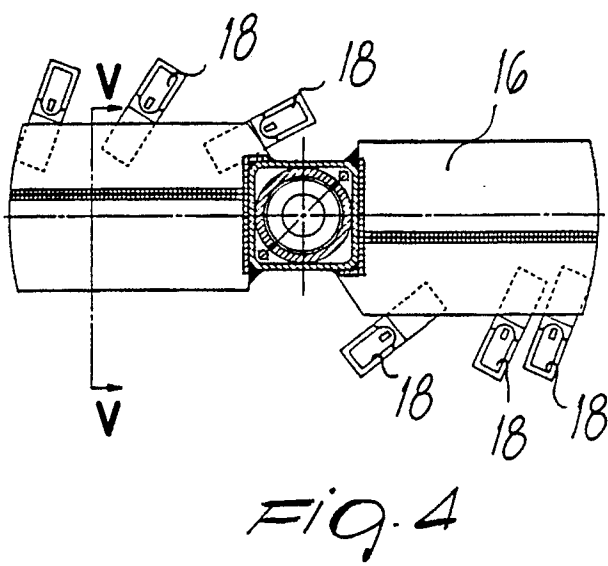
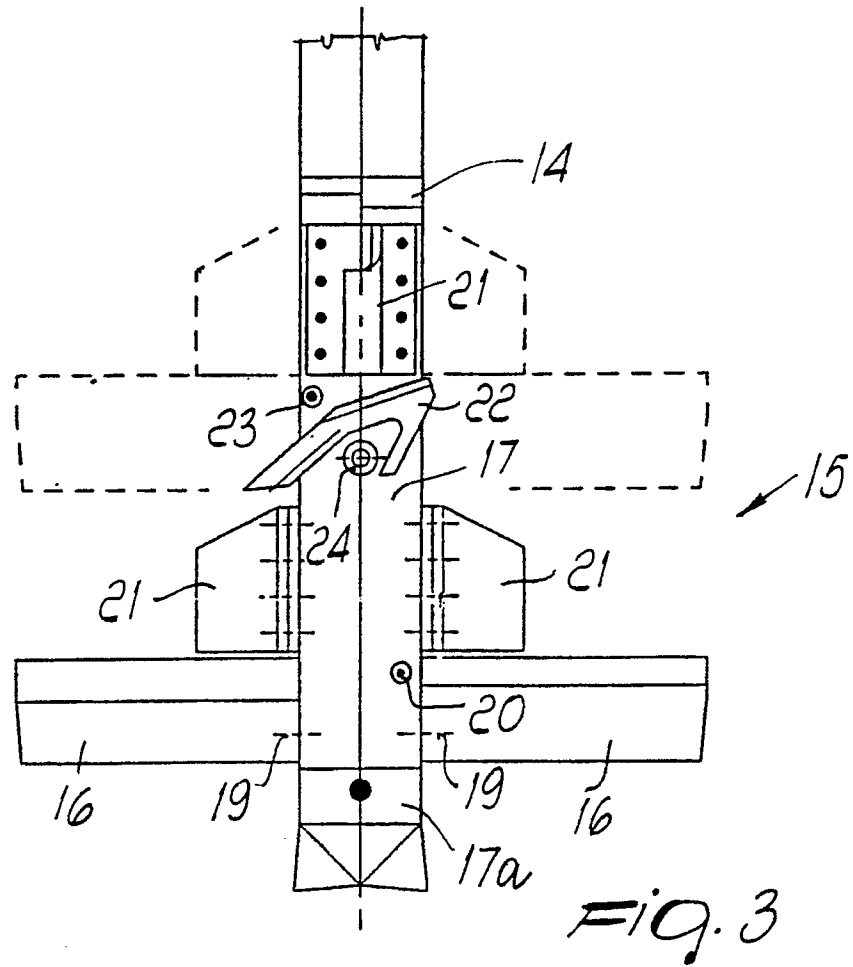

Fig. 2



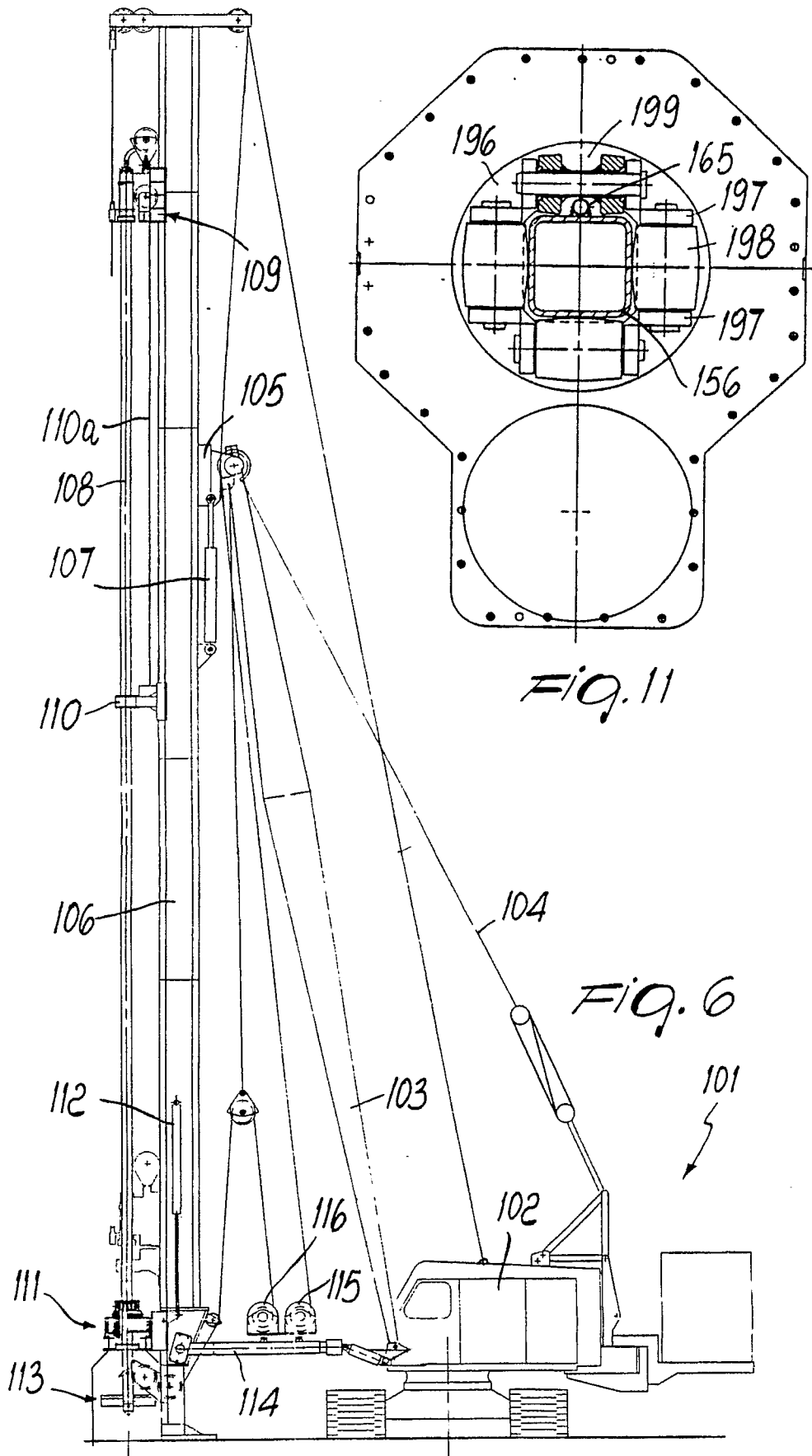
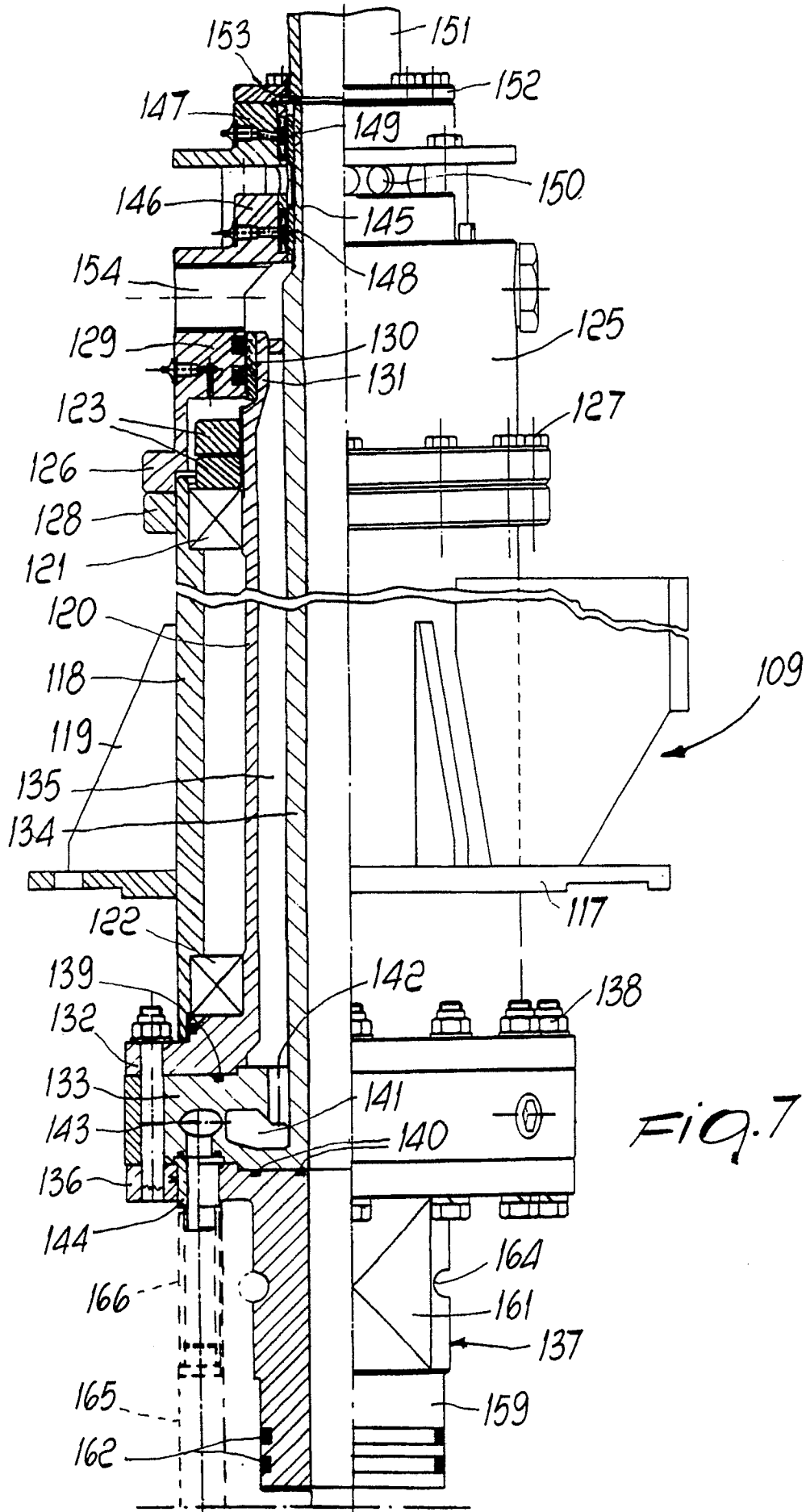
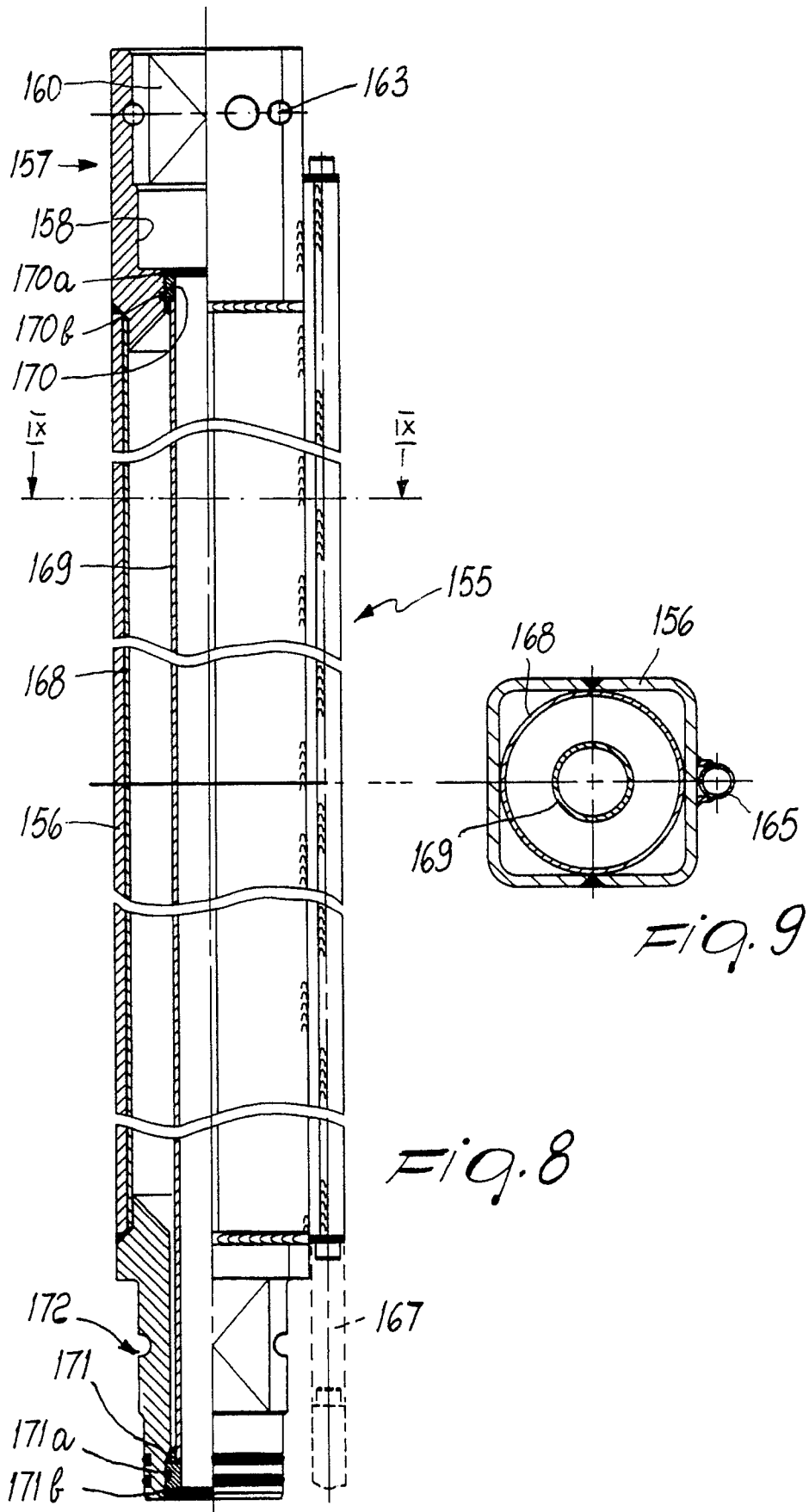
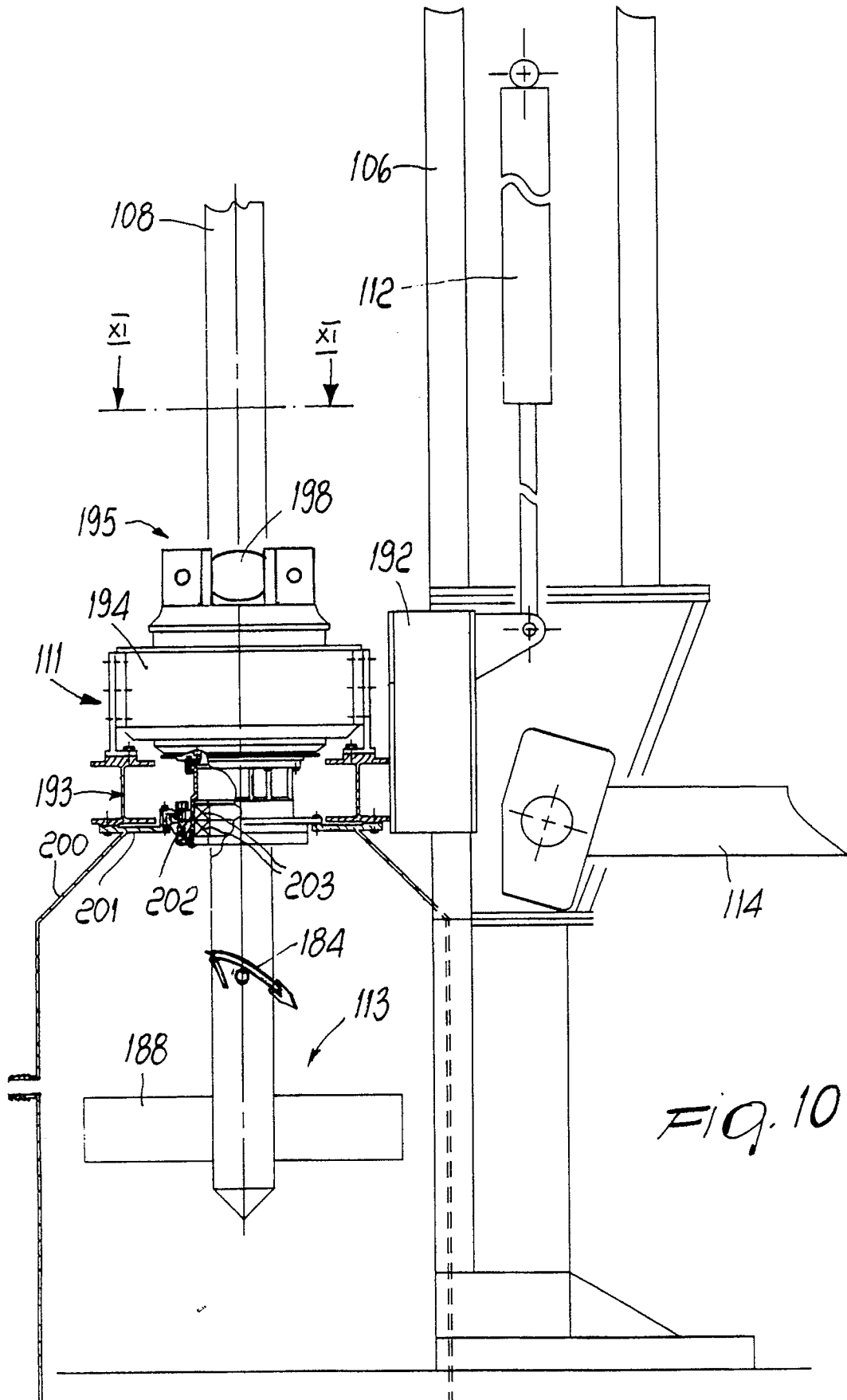

FIG. 11

FIG. 6







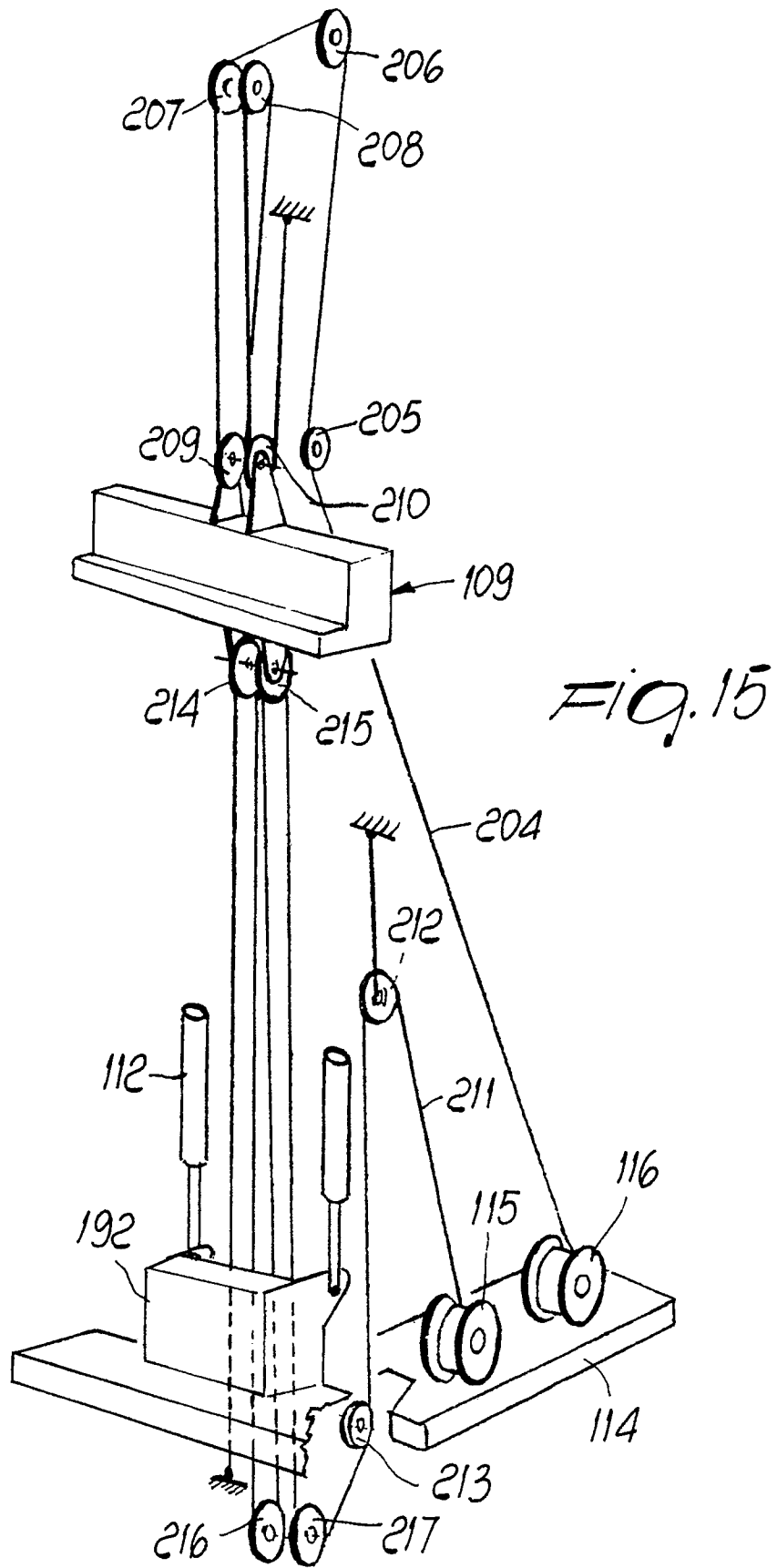

FIG. 15