

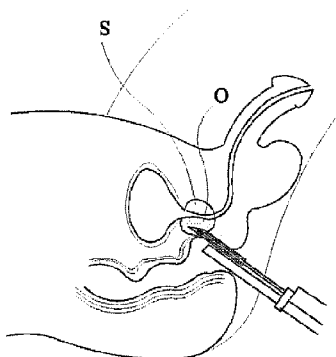

(86) Date de dépôt PCT/PCT Filing Date: 2016/01/21
 (87) Date publication PCT/PCT Publication Date: 2016/07/28
 (45) Date de délivrance/Issue Date: 2022/01/04
 (85) Entrée phase nationale/National Entry: 2017/12/11
 (86) N° demande PCT/PCT Application No.: PL 2016/000006
 (87) N° publication PCT/PCT Publication No.: 2016/118026
 (30) Priorité/Priority: 2015/01/22 (PL P.411023)

(51) Cl.Int./Int.Cl. *A61B 10/02* (2006.01)
 (72) Inventeurs/Inventors:
 GIBAS, ARTUR, PL;
 MATUSZEWSKI, MARCIN, PL;
 SIECZKOWSKI, MARCIN, PL
 (73) Propriétaire/Owner:
 DEBN SP. Z O.O., PL
 (74) Agent: DEETH WILLIAMS WALL LLP

(54) Titre : AIGUILLE DE BIOPSIE DE LA PROSTATE
 (54) Title: PROSTATE BIOPSY NEEDLE

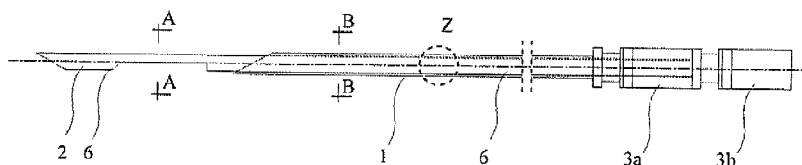

(57) **Abrégé/Abstract:**

Present invention solved the problem of complications occurred during transrectal prostate biopsy, mostly infectious and bleeding complications. Thus, the prostate biopsy needle according to the invention comprising a cannula (1), a pointed stylet (2), which is mounted slidably in the cannula (1), handles (3a, 3 b) for the biopsy gun, which are located on the back side of the needle. An inner surface (4) of the cannula (1) and / or an outer surface (5) of the cannula (1) and / or a surface of the stylet (2) is coated with at least one active layer (6) comprising a biologically active agent, wherein the active layer (6) preferably forms a biodegradable structure enabling controlled release of the biologically active agent.

(12) INTERNATIONAL APPLICATION PUBLISHED UNDER THE PATENT COOPERATION TREATY (PCT)

(19) World Intellectual Property
Organization
International Bureau(43) International Publication Date
28 July 2016 (28.07.2016)(10) International Publication Number
WO 2016/118026 A3(51) International Patent Classification:
A61B 10/02 (2006.01)(21) International Application Number:
PCT/PL2016/000006(22) International Filing Date:
21 January 2016 (21.01.2016)

(25) Filing Language: English

(26) Publication Language: English

(30) Priority Data:
P.411023 22 January 2015 (22.01.2015) PL

(72) Inventors; and

(71) Applicants : **SIECZKOWSKI, Marcin** [PL/PL]; Toruńska 18C/9, PL-80-747 Gdańsk (PL). **GIBAS, Artur** [PL/PL]; Rdestowa 146B/12, PL-81-577 Gdynia (PL). **MATUSZEWSKI, Marcin** [PL/PL]; Kmiecica 3, PL-80-279 Gdańsk (PL).(74) Common Representative: **SIECZKOWSKI, Marcin**; Toruńska 18C/9, PL-80-747 Gdańsk (PL).

(81) Designated States (unless otherwise indicated, for every kind of national protection available): AE, AG, AL, AM, AO, AT, AU, AZ, BA, BB, BG, BH, BN, BR, BW, BY, BZ, CA, CH, CL, CN, CO, CR, CU, CZ, DE, DK, DM,

DO, DZ, EC, EE, EG, ES, FI, GB, GD, GE, GH, GM, GT, HN, HR, HU, ID, IL, IN, IR, IS, JP, KE, KG, KN, KP, KR, KZ, LA, LC, LK, LR, LS, LU, LY, MA, MD, ME, MG, MK, MN, MW, MX, MY, MZ, NA, NG, NI, NO, NZ, OM, PA, PE, PG, PH, PL, PT, QA, RO, RS, RU, RW, SA, SC, SD, SE, SG, SK, SL, SM, ST, SV, SY, TH, TJ, TM, TN, TR, TT, TZ, UA, UG, US, UZ, VC, VN, ZA, ZM, ZW.

(84) Designated States (unless otherwise indicated, for every kind of regional protection available): ARIPO (BW, GH, GM, KE, LR, LS, MW, MZ, NA, RW, SD, SL, ST, SZ, TZ, UG, ZM, ZW), Eurasian (AM, AZ, BY, KG, KZ, RU, TJ, TM), European (AL, AT, BE, BG, CH, CY, CZ, DE, DK, EE, ES, FI, FR, GB, GR, HR, HU, IE, IS, IT, LT, LU, LV, MC, MK, MT, NL, NO, PL, PT, RO, RS, SE, SI, SK, SM, TR), OAPI (BF, BJ, CF, CG, CI, CM, GA, GN, GQ, GW, KM, ML, MR, NE, SN, TD, TG).

Published:

- with international search report (Art. 21(3))
- before the expiration of the time limit for amending the claims and to be republished in the event of receipt of amendments (Rule 48.2(h))

(88) Date of publication of the international search report:
22 September 2016

(54) Title: PROSTATE BIOPSY NEEDLE

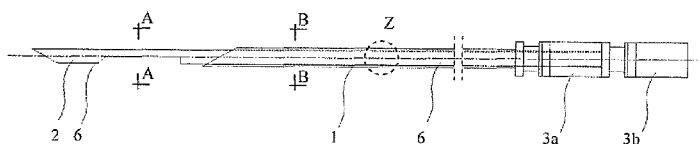

Fig. 1

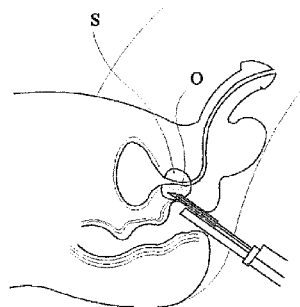

Fig. 39

(57) Abstract: Present invention solved the problem of complications occurred during transrectal prostate biopsy, mostly infectious and bleeding complications. Thus, the prostate biopsy needle according to the invention comprising a cannula (1), a pointed stylet (2), which is mounted slidably in the cannula (1), handles (3a, 3 b) for the biopsy gun, which are located on the back side of the needle. An inner surface (4) of the cannula (1) and / or an outer surface (5) of the cannula (1) and / or a surface of the stylet (2) is coated with at least one active layer (6) comprising a biologically active agent, wherein the active layer (6) preferably forms a biodegradable structure enabling controlled release of the biologically active agent.

Prostate biopsy needle

The present invention relates to the prostate biopsy needle for performing transrectal prostate biopsy.

Prostate cancer is the most common malignancy diagnosed in men in Europe, Australia and North America. The average chance to develop this cancer during lifetime is approximately 15% and its incidence rate is estimated to be about 150 per 100 000 male. It is associated with high costs of diagnosis and treatment, which are estimated at 8.43 billion € per year in Europe.

Transrectal ultrasound-guided prostate biopsy is the standard method for pathological diagnosis of prostate cancer and is one of the most common urological procedures performed around the world. Only in the United States of America, there are approximately 800 000 prostate biopsies performed annually.

Patent application US 5014717 discloses a punch-biopsy apparatus for prostate biopsy comprising a cannula, a stylet that is mounted slidably in the cannula, handles for a biopsy gun which are located on the back side of the needle. Known prostate biopsy needle is inserted into the prostate under transrectal ultrasound guidance. Triggering the spring mechanism results in a rapid sliding of the stylet, and then pulling the cutting cannula on the stylet. This enables to collect the tissue sample from the desired area of a prostate. During the biopsy at least eight cores should be taken from different parts of the prostate. This multiplies the risk of complications mentioned below.

The most common complications following transrectal prostate biopsy performed by known prostate biopsy needles are hematuria and hematospermia. However, the most serious clinical problems are infectious complications occur after the prostate biopsy. During the procedure, after introduction of the needle through the rectum, the intestinal bacteria are transferred into the blood and the prostate. Patients undergoing prostate biopsy are exposed to urinary tract infections, prostatitis, and even severe septic complications. Therefore, it is

AMENDED SHEET

recommended that periprocedural oral antibacterial prophylaxis should be administered. The most commonly used antibiotics in antibacterial prophylaxis prior transrectal prostate biopsy are oral fluoroquinolones. In recent years, numerous scientific publications have reported the rapid spread of intestinal bacterial strains resistant to this group of antibiotics. This phenomenon is responsible for an increase in the percentage of severe infectious complications occurring after the prostate biopsy performed by the known biopsy prostate needle.

Hitherto, an effective and fully accepted strategy to reduce the infections caused by transrectal prostate biopsy still has not been defined. Attempts to use oral or intravenous antibiotics from other groups appear to be insufficiently effective. While, simultaneous use of multiple antibiotics in prophylaxis can result in significant side effects.

The known prostate biopsy needle does not allow to overcome the problem of hematuria, hematospermia and infectious complications which occur as a result of transrectal invasive procedures of prostate biopsy.

A known solution of this problem is a transperineal prostate biopsy. However this method has some significant disadvantages including the need for epidural or general analgesia, which is an additional burden for the patient and special equipment requirements, which increases the costs of diagnosis.

There are known multiple methods to modify the surface of medical devices for insertion into human organs and body cavities for long-term period. Examples of such medical devices include: stents, vascular grafts, catheters, urological, orthopedic implants and contact lenses. Their surface is usually coated with a bioactive layer. The presence of a bioactive layer enables to release biologically active substances from the surface of such devices. Biologically active agents are usually used to reduce the risk of vessels occlusion (stents and vascular grafts) or prevent infection (orthopedic implants or dental catheters,

urology, contact lenses, vascular prostheses) that can develop due to long exposure to medical device implanted into the body.

There are also known urological catheters, contact lenses, vascular, orthopedic or dental implants, which surface is coated with a bioactive layer releasing antimicrobial agents. Furthermore, there are known medical devices such as catheters, urological and vascular stents, which surface is coated with an additional protective layer that enables stable release of active agents and / or with additional binder layer which strengthens the connection of bioactive layer with the surface of the medical device.

The application of beta-cyclodextrin complex with vancomycin on the surface of the vascular prosthesis made of poly(ethylene terephthalate) is known from the publication [Blanchemain N et al. European Journal of Vascular and Endovascular Surgery 2005, 29, 628-632]. Cyclodextrins are cyclic oligosaccharides with a toroid-shaped molecular structure, characterized by a hydrophilic outer surface and a lipophilic central cavity which enable them to form inclusion compounds with antibiotics.

The formation of the antimicrobial bioactive layer on the surface of titanium medical implant using poly(vinyl alcohol), chitosan and silver ions is known from the publication [Mishra SK et al. Mechanically stable antimicrobial chitosan-PVA-silver nanocomposite coatings Deposited on Titanium Implants, Carbohydrate Polymers, 2015, 121, 37-48]. The contact lenses with a bioactive layer formed of poly(L-glutamic acid) containing ciprofloxacin are known from literature [Ciolino JB et al., Drug-Eluting A Contact Lens. Investigative Ophthalmology and Visual Science, 2009, 50 (7), 3346-3352].

Patent No PL214742 discloses a method for preparing an antibacterial layer on the surface of the catheters by immobilization of antimicrobial substances due to fixed connection through the use of the polysaccharide.

There are known silicone catheters with antibacterial properties, where the bioactive layer is formed by immersing the catheter in a solution composed of polymers: poly(ethylene-co-vinyl acetate), poly(ethyleneoxide) and poly(dimethylsiloxane) containing antibiotics [Park JH et al., Journal of Biomaterials Science, Polymer Edition, 2003, 14 (9), 951-962].

All of the known medical devices coated with bioactive layer are designed for implantation into the human body permanently or for a long period of time. The biopsy prostate needle is not such a device since it is introduced into the body for relatively short time only during duration of procedure.

The object of the invention is to provide the prostate biopsy needle, which reduces the periprocedural complications. The invention therefore relates to prostate biopsy needle, which provide protection against potential infection and perioperative bleeding complications. In particular the biopsy needle with specific construction that allow the administration of biologically active agents during the prostate biopsy.

Unexpectedly, we found that adequate and very distinctive coating of biopsy needle with bioactive layer or relevant mechanical construction of a biopsy needle enables release or direct application of the biological active compounds to a prostate gland.

Thus according to the invention the prostate biopsy needle comprising a cannula, a pointed stylet mounted slidably in the cannula, with biopsy gun handles located on the back side of the needle, and has the characteristic that an inner

surface of the cannula and / or an outer surface of the cannula and / or a surface of the stylet is coated with at least one active layer comprising a biologically active agent. The active layer preferably forms a biodegradable structure enabling controlled release of the biologically active agent.

In preferred embodiment of the invention, the inner surface of the cannula and / or the outer surface of the cannula and / or the surface of the stylet form an extended surface, preferable grooved and / or rough and / or porous surface.

In embodiment, the extended surface forms pits with depth ranged from 0.001 mm to 0.1 mm, preferably from 0.01 mm to 0.06 mm.

In further embodiment, the part of inner surface of the cannula and / or the part of outer surface of cannula is coated with the active layer, wherein the part is an area ranged from 0.1 cm to 10 cm in length, preferably from 4 cm to 8 cm, preferably extended from a tip of the cannula and / or the front part of the surface of stylet is coated with the active layer, wherein the part is the area ranged from 0.1 cm to 10 cm in length, preferably from 4 cm to 8 cm, preferably extended from the tip of stylet.

In further embodiment, the active layer is applied on the binder layer wherein the inner surface of the cannula and / or the outer surface of the cannula and / or the surface of stylet is coated with the binder layer.

In further embodiment, the active layer contains binder agent.

In further embodiment, the surface of active layer is coated with the protective layer enabling stable release of the biologically active agent, preferably in the form of polymer layer.

In embodiment, the protective layer has a form of a fine mesh with the cells size from 1 μm to 500 μm , preferably 10 μm to 100 μm .

In further embodiment, the biologically active agent of the active layer is an antibacterial substance and/or an anti-inflammatory substance and/or an analgesic substance and/or an anesthetic substance and/or the antihemorrhagic substance.

In embodiment, the antibacterial substance and / or the anti-inflammatory substance is an antibiotic and / or the chemotherapeutic agent and / or zinc ions and / or silver ions.

To solved the problem, the present invention also provide prostate biopsy needle comprising a cannula and pointed stylet mounted slidably in the cannula which is characterized by longitudinal pass-through-hole channel formed in the wall of the cannula. The channel has closed profile in cross-section view, and the channel extends through the entire length of the wall of cannula or the part the length thereof. In preferred embodiment of this invention, the channel is circular-shaped in cross-section with the diameter of 0.1 mm to 2.0 mm, preferably from 0.5 mm to 0.7 mm.

In further embodiment, the channel protrudes over the outer surface of the cannula, preferably protrudes over the area of 130 mm to 155 mm from the cannula.

According to the invention, biopsy needle enables for direct delivery surface elution of different antibiotics, and/or anti-inflammatory drugs and/or other substances with a biological activity into the prostate. This does not require additional punctures of the prostate since biologically active agents are released simultaneously during prostate biopsy. The positive effect of this invention is that

biologically active agents are introduced through the needle precisely to the starting point of potential infection. This allows for reduction or complete elimination of oral or intravenous antimicrobial prophylaxis prior transrectal prostate biopsy. Furthermore, the effective dose of drugs administered directly into the prostate may be significantly lower than in intravenous or oral form. The invention enables simultaneous topical application of a set of antibiotics, which can broaden the spectrum of antimicrobial protection, with a lower risk of side effects. The invention set a completely new approach of periprocedural antimicrobial prophylaxis for prostate biopsy. The invention also enables the simultaneous administration of several active agents like anesthetics and / or anti-inflammatory and / or antibacterial and / or antihemorrhagic substances.

The invention is shown in more details in the examples and drawings wherein Fig. 1 shows a biopsy needle in a top view, Fig. 2 biopsy needle in a side view, Fig. 3 a cross section of the stylet taken along the line A-A in Fig. 1, Fig. 4 a cross-section through the stylet and cannula along line B-B in Fig. 1, Fig. 5 enlarged longitudinal section of the stylet and the cannula at the point Z in Fig. 1 and Fig. 2; Fig. 6 biopsy needle in a side view, in a further embodiment, Fig. 7 enlarged longitudinal section of the stylet and the cannula at the point Y of Fig. 6; Fig. 8 biopsy needle in a side view, in a further embodiment, Fig. 9 enlarged longitudinal section of the stylet and the cannula at the point X of Fig. 8; Fig. 10 biopsy needle in a side view, in a further embodiment, Fig. 11 enlarged longitudinal section through the stylet and cannula in place W of Fig. 10; Fig. 12 biopsy needle in a side view, in a further embodiment, Fig. 13 enlarged longitudinal section of the stylet and the cannula at the point V of Fig. 13; Fig. 14 biopsy needle in a side view, in a further embodiment, Fig. 15 enlarged longitudinal section of the stylet and the cannula at the point U of Fig. 14; Fig. 16 biopsy needle in a side view, in a further embodiment, Fig. 17 enlarged longitudinal section of the stylet and the cannula at the point T of Fig. 16; Fig. 18 biopsy needle in a side view, in a further embodiment, Fig. 19 enlarged

longitudinal section of the stylet and the cannula at the point S of Fig. 18, Fig. 20 enlarged cannula surface; Fig. 21 biopsy needle in a side view, in a further embodiment, Fig. 22 enlarged longitudinal section of the stylet and the cannula at the point R of Fig. 21, Fig. 23 enlarged axonometric view of the extended layers from segment I of the biopsy needle from Fig. 21; Fig. 24 biopsy needle in a side view, in a further embodiment, Fig. 25 enlarged longitudinal section of the stylet and the cannula at the point Q of Fig. 24, Fig. 26 enlarged axonometric view of the extended layers from segment II of the biopsy needle from Fig. 24; Fig. 27 biopsy needle in a side view, in a further embodiment, Fig. 28 enlarged longitudinal section of the stylet and the cannula at the point P of Fig. 27; Fig. 29 biopsy needle in a side view, in a further embodiment, in Fig. 30 enlarged longitudinal section of the stylet and the cannula at the point O from Fig. 29, Fig. 31 enlarged axonometric view of the extended layers from segment III of the biopsy needle from Fig. 29; Fig. 32 biopsy needle in a top view, in a further embodiment, Fig. 33 biopsy needle in a side view, Fig. 34 cross-section of the stylet taken along the line CC of Fig. 32, 33, 37 and 38; Fig. 35 is a cross section of the stylet and the cannula along the line DD of Fig. 32, 33, 37 and 38; Fig. 36 enlarged longitudinal section through the stylet and cannula N of Fig. 32; Fig. 37 biopsy needle in a top view, in a further embodiment, Fig. 38 biopsy needle in a side view, Fig. 39 anatomical chart of prostate surrounding during biopsy.

Example 1

A steel biopsy needle with 200 mm length, comprises a pointed cannula 1, pointed stylet 2 mounted slidably in the cannula 1 and in the back the polypropylene holders for the biopsy gun - a cannula holder 3a and stylet holder 3b. The outer diameter of the cannula 1 is 1.93 mm, the inner diameter of the cannula 1 is 1.70 mm, and the stylet 2 diameter is 1.65 mm.

The inner surface 4 of the cannula 1 and the outer surface 5 of the cannula 1 and the surface of the stylet 2, over the entire length of the steel needles are coated

with the active layer 6 containing the biologically active agents, as shown in Figs. 1-5. Active layer 6 has a biodegradable form allows for the controlled release of the biologically active agent by dissolving in water contained in the blood and biopsied tissue. The active layer contains two antibiotics - ciprofloxacin and amikacin which form inclusion complex with β -cyclodextrin. An active layer 6 was obtained by mixing in a centrifuge (5 min, 30 rpm), ciprofloxacin, amikacin and β -cyclodextrin in a molal ratio 1: 1: 2. The mixture of compounds was dissolved in 0.14% aqueous solution of a nitrogen hydride (III). The obtained solution was filtered. After immersion of the steel cannula 1 and stylet 2 in solution, the freeze-drying process was carried out to perform the active layer 6 fixation. As shown in Fig. 39 by using the biopsy gun and a biopsy needle under transrectal ultrasound, prostate cores were collected in a standard way. During the procedure, ciprofloxacin and amikacin were directly release from the biodegradable active layer 6 into the prostate tissue by disintegration of inclusion complex of β -cyclodextrin with antibiotics. *In vitro* and *in vivo* studies confirmed the release of drugs from the active layer 6 applied to the steel surface of the biopsy needle and the antibacterial effect in the action area of bioactive agents.

Example 2

The needle is made as described in Example 1, except that the inner surface 4 of the cannula 1 and part of the outer surface 5 of the cannula 1, 5cm long from the tip of it, is coated with an active layer 6 as shown in Fig. 6 and Fig. 7. The active layer 6 contains two antibiotics: ciprofloxacin and amikacin, as described in Example 1.

Example 3

The needle is made as described in Example 1, except that the part of stylet 2 surface, 7cm long from the tip of it, is coated with an active layer 6, as

shown in Fig. 8 and Fig. 9. The active layer 6 contains two antibiotics: ciprofloxacin and amikacin, as described in Example 1.

Example 4

The needle is made as described in Example 1, except that the active layer 6 is applied on the binder layer 7, which is placed on the outer surface 5 of the cannula 1 and the inner surface 4 of the cannula 1 and the surface of the stylet 2, as shown in Fig. 10 and Fig. 11. The binder layer 7 is made of poly(vinyl alcohol). The binder layer 7 was obtained by dipping the cannula 1 in a solution of acetone and drying, and then dipping in an aqueous solution of 0.5 mM/L of poly(vinyl alcohol) (molecular weight of 49,000 g mol⁻¹). On such binder layer 7 the active layer 6, obtained as described in Example 1, was applied.

Example 5

The needle is made as described in Example 1, except that the active layer 6 is applied on the binder layer 7, which covers the outer surface 5 of the cannula 1, as shown in Figs. 12 and Fig. 13. The binder layer 7 is made of polyethylene (vinyl alcohol). Binder layer 7 was obtained as described in Example 4 except that in the solution was immersed temporarily sealed cannula 1. Then, the outer surface 5 of the cannula 1 was coated by spraying with antihemorrhagic substance - potassium aluminum sulfate dodecahydrate, thus leading to formation of an active layer 6. *In vitro* and *in vivo* studies have confirmed the role of this biopsy needle to accelerate the coagulation process.

Example 6

The needle is made as described in Example 1, except that the outer surface 5 of the cannula 1 is coated with the active layer 6, as shown in Fig. 14 and Fig. 15. The active layer 6 contains a biologically active agent - fibrinogen, a

protein which is involved in the coagulation process. Temporarily sealed cannula 1 was dipped ten times in an aqueous solution of fibrinogen (10 mg/ml), and dried temporarily. *In vitro* and *in vivo* studies have confirmed the role of this biopsy needle to accelerate the coagulation process and thus minimize the risk of bleeding.

Example 7

The needle is made as described in Example 1, except that the active layer 6 is applied to the binder layer 7, which is applied on the outer surface 5 of the cannula 1 and the surface of the stylet 2, as shown in Fig. 16 and Fig. 17. The active layer 6 contains a biologically active antiseptic agent - zeolite, comprising of 2.5% silver ions and 14% zinc ions. The binder layer 7 is made of poly(vinyl alcohol). The binder layer 7 was obtained by biopsy needle immersion in acetone solution and drying. Then temporarily sealed cannula 1 was immersed in an aqueous solution of 0.5 mM/L of poly(vinyl alcohol) (molecular weight about 49 000 g · mol⁻¹). Then, the binder layer 7 was coated by spraying with zeolit. The needle was dried in 50°C for 1 hour to obtain the active layer 6 fixation.

Example 8

The needle is made as described in Example 1, except that the outer surface 5 of the cannula 1 is coated with active layer 6 as shown in Figs. 18-20. The surface of the active layer 6 is covered with a protective layer 8 to achieve stable release of the biologically active agent during whole prostate biopsy procedure. The protective layer 8 is made of poly(glycolic acid). The surface of the active layer 6 was coated by spraying with poly(glycolic acid) which forms a net-like protective layer 8. This layer delays the release of the biologically active agent from the active layer 6. The active layer 6 was obtained by mixing in a centrifuge (5 min, 30 rpm) antibiotic - levofloxacin with β -cyclodextrin in molal

ratio 1:1. Further procedure was as described in Example 1, except that in the solution was immersed the temporarily sealed cannula.

Example 9

The needle is made as described in Example 1, except that the outer surface 5 of the cannula 1 and stylet 2 surface have an extended form with porous pits, as shown in Figs. 21-23. Pores 9a were obtained by micro laser engraving with a diameter of 0.1 mm and a depth of 0.05 mm. The active layer 6 is applied on an extended porous form 9a of the outer surface 5 of the cannula 1 and on an extended porous surface 9a of the stylet 2. The outer surface 5 of the cannula 1 and stylet surface 2 were coated with a mixture of β -cyclodextrin with ciprofloxacin in the molal ratio 1:1. Further procedure was as described in Example 1, except that in the solution was immersed the temporarily sealed cannula.

Example 10

The needle is made as described in Example 1, except that the outer surface 5 of the cannula 1 and surface of stylet 2 have an extended form with grooved pits. The active layer 6 containing a complex of β -cyclodextrin with an antibiotic - ciprofloxacin was formed on extended grooved form 9b of the outer surface 5 of the cannula 1 and on the extended grooved form 9b of stylet 2, as shown in Fig. 24-26. Grooves 9b were formed parallel to the axis of the cannula 1 and stylet 2 to accumulate the antibiotic complex what allow an increase dose of active compound of the layer. The dimensions of the grooves 9b were 0.05 mm x 0.05 mm x 100 mm. Grooves 9b were obtained by micro laser engraving from the tip of the cannula 1 and stylet 2. The active layer 6 is applied on an extended grooved form 9b of the outer surface 5 of the cannula 1 and on an extended grooved surface 9b of stylet 2. The outer surface 5 of the cannula 1 and stylet

surface 2 were coated with a mixture of β -cyclodextrin with ciprofloxacin in the molal ratio 1:1. Further procedure was as described in Example 1, except that in the solution was immersed the temporarily sealed cannula.

Example 11

The needle is made as described in Example 1, except that the active layer 6 is applied on the outer surface 5 of the cannula 1, as shown in Fig. 27 and Fig. 28. The active layer 6 contains a biologically active antimicrobial agent - levofloxacin. The active layer 6 was obtained by mixing in a centrifuge (5 min, 30 rpm) antibiotic - levofloxacin with β -cyclodextrin in molal ratio 1 : 1. Further procedure was as described in Example 1, except that in the solution was immersed the temporarily sealed cannula. The surface of the active layer 6 is coated by spraying with the aqueous solution of 0.5 mM/L of poly(vinyl alcohol) (molecular weight about 49 000 g · mol⁻¹) to form a protective layer 8 which was made to achieve stable release of the biologically active agent. The protective layer 8 had a thickness of 0.02 mm.

Example 12

The biopsy needle is made as described in Example 1, except that the outer surface 5 of the cannula 1 is coated with two active layers 6, as shown in Figs. 29-31. The first active layer 6 is applied to the binder layer 7 which is located on the outer surface 5 of the cannula 1. Binder layer 7 was obtained by dipping the cannula 1 in a solution of acetone and drying, and then dipping in an aqueous solution of 0.5 mM/L of poly(vinyl alcohol) (molecular weight of 49,000 g · mol⁻¹). On such binder layer 7 the first active layer 6, obtained as described in Example 1, was applied, except that the cannula 1 was temporarily sealed. Then, the first active layer 6 was coated by spraying with poly(glycolic acid) which forms a net-like protective layer 8. This layer delays the release of the biologically active agent from the first active layer 6. The second active layer 6, was applied

on the protective layer 8. The second active layer was obtained as in Example 1, except that the cannula 1 was temporarily sealed.

Example 13

A steel biopsy needle with 200 mm length, comprises a pointed cannula 1, pointed stylet 2 slidably located in the cannula 1 and in the back the polypropylene holders for the biopsy gun - a cannula holder 3a and stylet holder 3b. The outer width of the cannula 1 is 1.52 mm, its height is 2.22 mm, and the stylet 2 diameter is 1.27 mm as shown in Figs. 32-36. The cannula 1 has a circular cross-section and one axis of symmetry. The cannula 1 contains main channel with diameters of 1.32 mm (for the stylet) and a longitudinal pass-through-hole channel 10 of cannula 1. The additional channel 10 of circular shaped in cross section with the diameter of 0.5 mm, passes through 150 mm of cannula 1, beginning at its pointed end, protrudes over the outer surface 5 of the cannula 1 and then transfer into the steel connector 11. The connector 11 has a tube form, a length of 25 mm, an inner diameter of 0.5 mm and an external diameter 0.65 mm. The connector 11 of the channel 10 is connected to a flexible tube 12, made of poly(vinyl chloride), with an internal diameter of 0.5 mm and a length of 200 mm. The flexible tube 12 is connected with a 5ml syringe 13. As shown in Fig. 39 by using the biopsy gun and a biopsy needle under transrectal ultrasound, prostate cores s were collected in a standard way. During the procedure, at each sequence of collecting biopsy samples 0.1 ml of an aqueous solution of levofloxacin (5 mg/ml) and 0.1 ml of lidocaine hydrochloride (20 mg/ml) were administered through the additional channel 10. *In vitro* and *in vivo* studies confirmed the antibacterial effect in the action area o of bioactive agents. The analgesic effect was confirmed *in vivo*.

Example 14

A steel biopsy needle with 200 mm length, comprises a pointed cannula 1, pointed stylet 2 slidably located in the cannula 1 and in the back the polypropylene holders for the biopsy gun - a cannula holder 3a and stylet holder 3b. The outer width of the cannula 1 is 1.52 mm, its height is 2.22 mm, and the stylet 2 diameter is 1.27 mm as shown in Figs. 34-38. Cannula 1 has a circular cross-section and one axis of symmetry. The cannula 1 contains main channel with diameters of 1.32 mm (for the stylet) and a longitudinal pass-through-hole channel 10 of cannula 1. The additional channel 10 of circular shaped in cross section with the diameter of 0.5 mm, passes through the entire length of the cannula 1, from its pointed end to the holder 3a. As shown in Fig. 39 by using the biopsy gun and a biopsy needle under transrectal ultrasound, prostate cores were collected in a standard way. During the procedure, at each sequence of collecting biopsy samples 0.1 ml of an aqueous solution of levofloxacin (5 mg/ml) and 0.1 ml of lidocaine hydrochloride (20 mg/ml) were administered through the additional channel 10. *In vitro* and *in vivo* studies confirmed the antibacterial effect in the action area of bioactive agents. The analgesic effect was confirmed *in vivo*.

Claims

1. A prostate biopsy needle comprising a cannula (1), a pointed stylet (2), which is mounted slidably in the cannula, handles (3a, 3b) for a biopsy gun, which are located on the back side of the needle, characterized in that part of an outer surface (5) of the cannula (1) or part of a surface of the stylet (2) is coated with at least one active layer (6) comprising an antibacterial substance, wherein the active layer (6) forms a biodegradable structure enabling controlled release of the antibacterial substance wherein the coated part is an area ranging from 0.1 cm to 10 cm in length.
2. The needle according to the claim 1, wherein the outer surface (5) of the cannula (1) or the surface of the stylet (2) form an extended surface (9) in a form of grooved and / or rough or porous surface (9).
3. The needle according to claim 2, wherein the extended surface (9) forms pits with depth ranging from 0.001 mm to 0.1 mm.
4. The needle according to claim 3, wherein the extended surface (9) forms pits with depth ranging from 0.01 mm to 0.06 mm.
5. The needle according to any one of claims 1-4, in which the part of the outer surface (5) of the cannula (1) is coated with the active layer (6), wherein the coated part is an area ranging from 4 cm to 8 cm, or the part of the surface of stylet (2) is coated with the active layer (6), wherein the coated part is an area ranging from 4 cm to 8 cm.
6. The needle according to claim 5, in which the coated part of the outer surface (5) of the cannula (1) extends from a tip of the cannula (1) and/or the coated part of the surface of the stylet extends from the tip of stylet (2).

7. The needle according to any one of claims 1-6, in which the active layer (6) is applied on a binder layer (7) wherein the outer surface (5) of the cannula (1) or the surface of stylet (2) is coated with the binder layer (7).
8. The needle according to any one of claims 1-7, in which the active layer (6) contains a binder agent.
9. The needle according to any one of claims 1-8, in which the surface of active layer (6) is coated with a protective layer (8) enabling stable release of the biologically active agent.
10. The needle according to claim 9, wherein the protective layer is a polymer layer.
11. The needle according to claim 9 or claim 10, wherein the protective layer (8) has a form of a fine mesh with the cells size from 1 μm to 500 μm , preferably 10 μm to 100 μm .
12. The needle according to claim 11, wherein the protective layer (8) has a form of a fine mesh with the cells size from 10 μm to 100 μm .
13. The needle according to claim 1, in which the antibacterial substance is an antibiotic or a chemotherapeutic agent or zinc ions or silver ions.

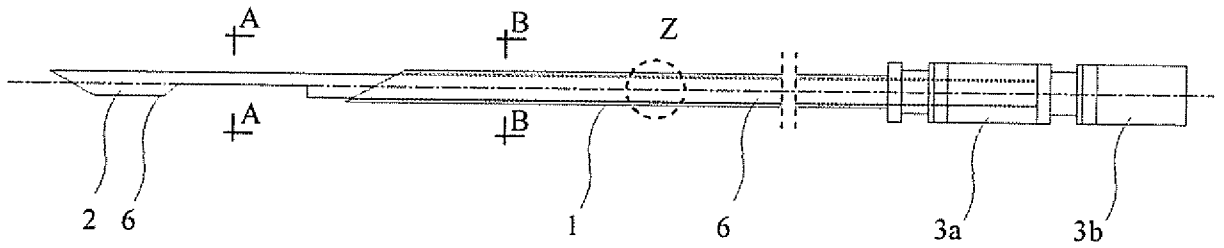

Fig. 1

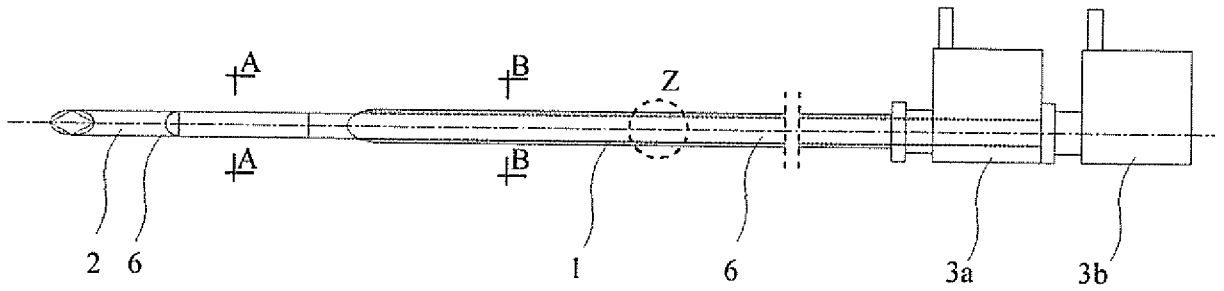

Fig. 2

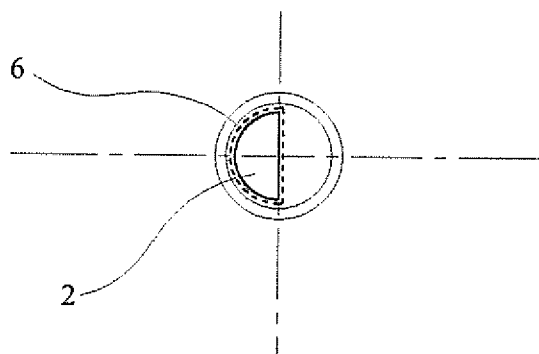

Fig. 3

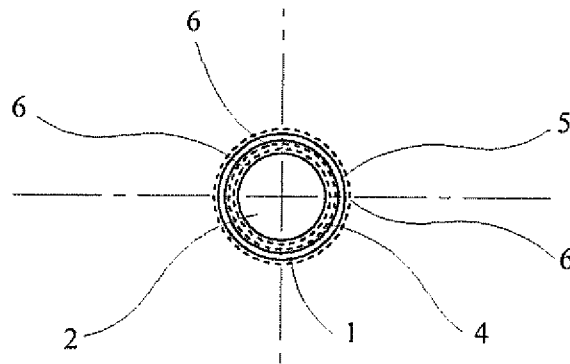

Fig. 4

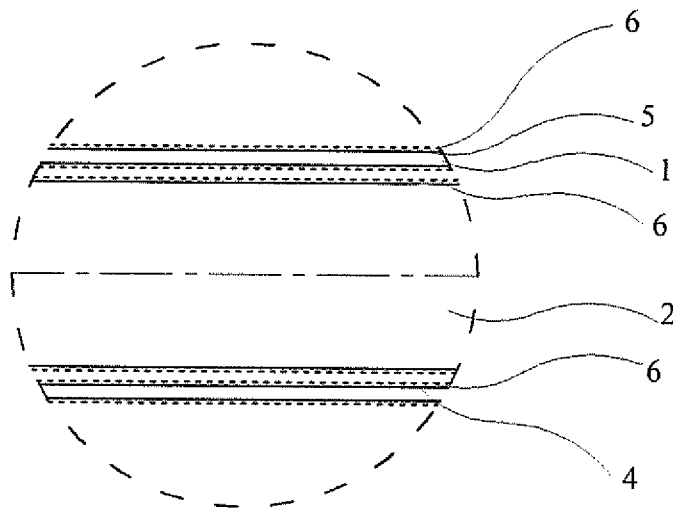

Fig. 5

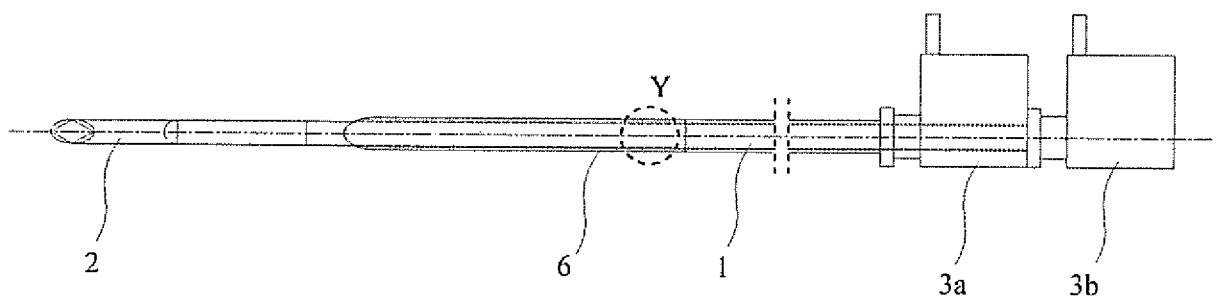

Fig. 6

3/15

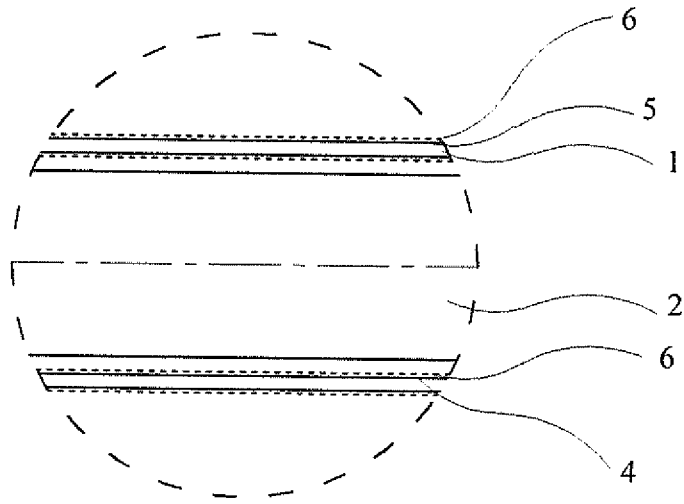

Fig. 7

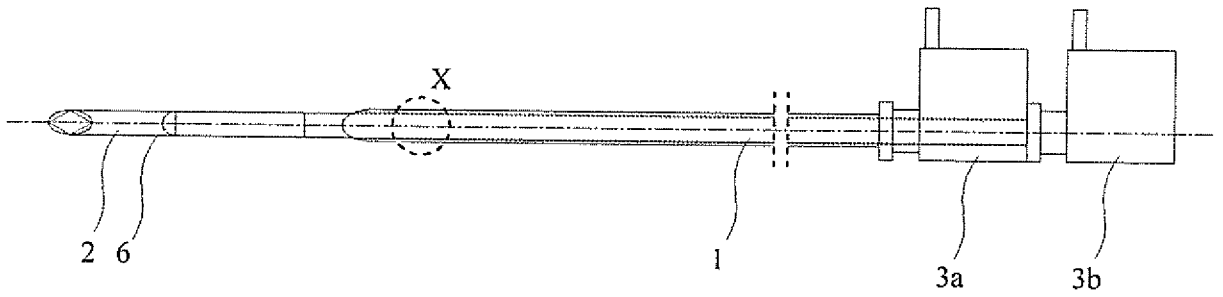

Fig. 8

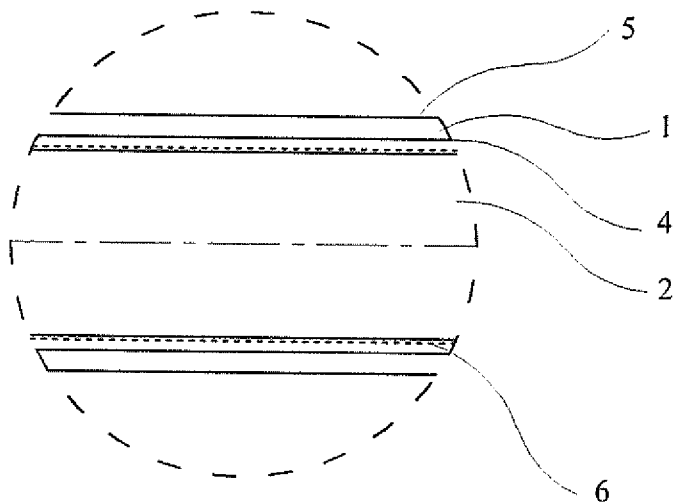

Fig. 9

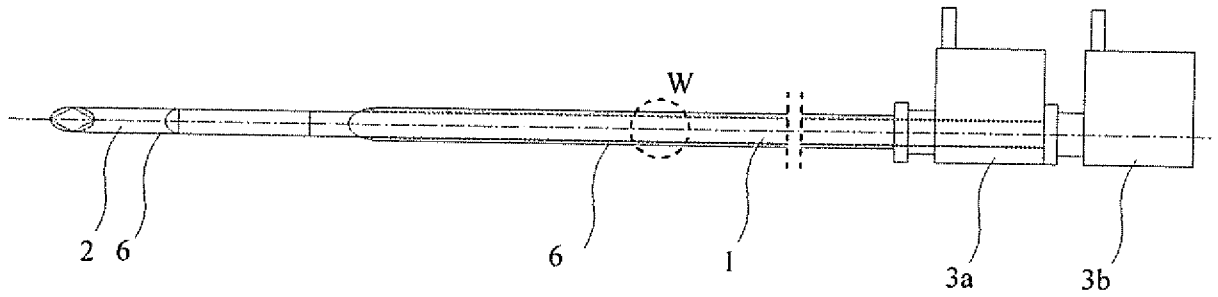

Fig.10

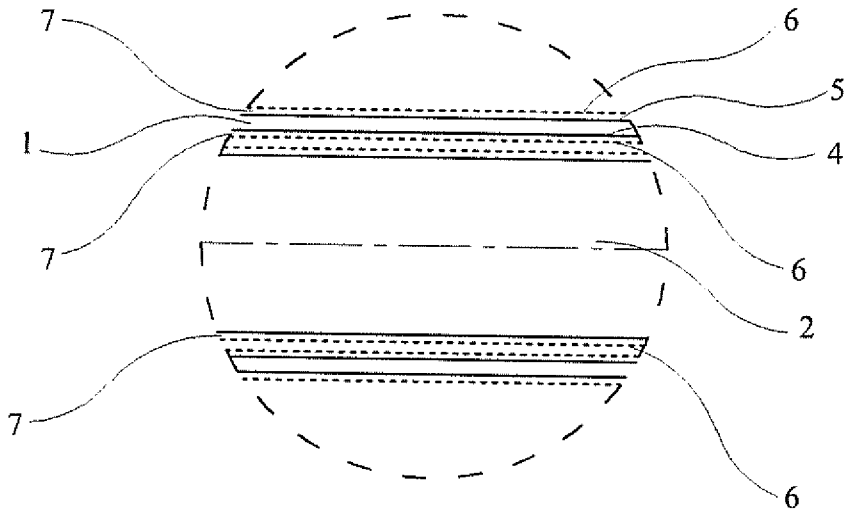

Fig. 11

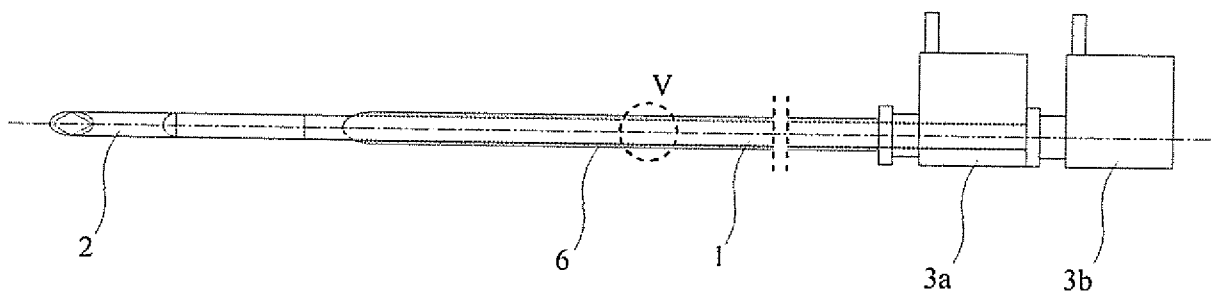

Fig.12

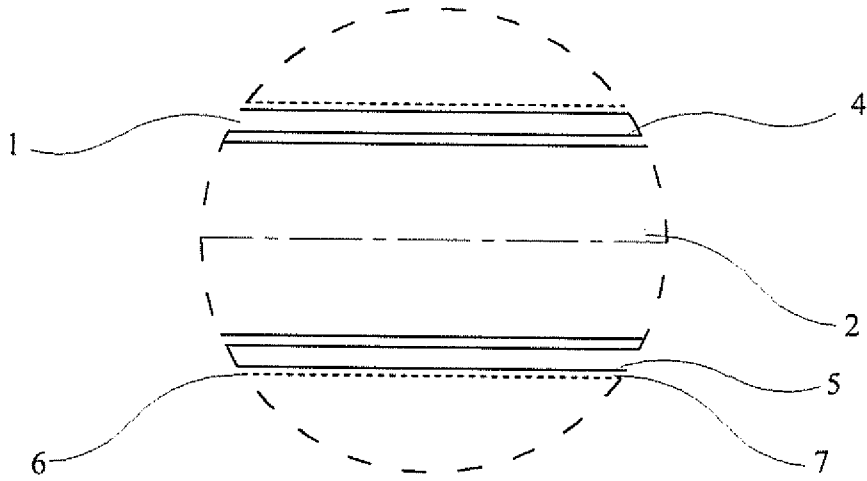

Fig. 13

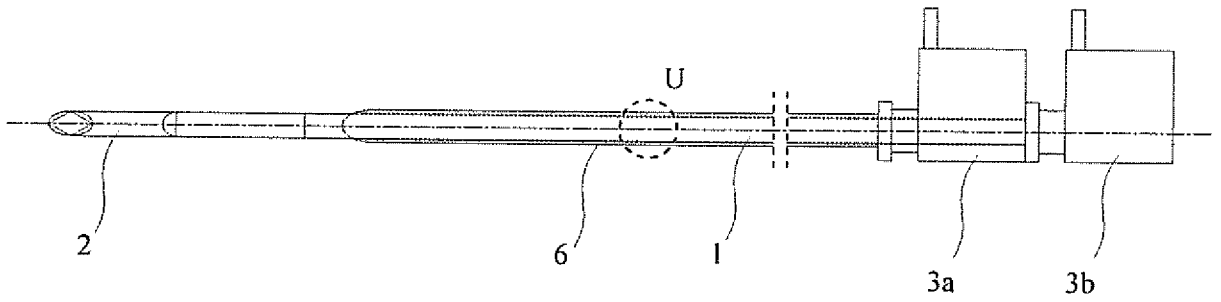

Fig. 14

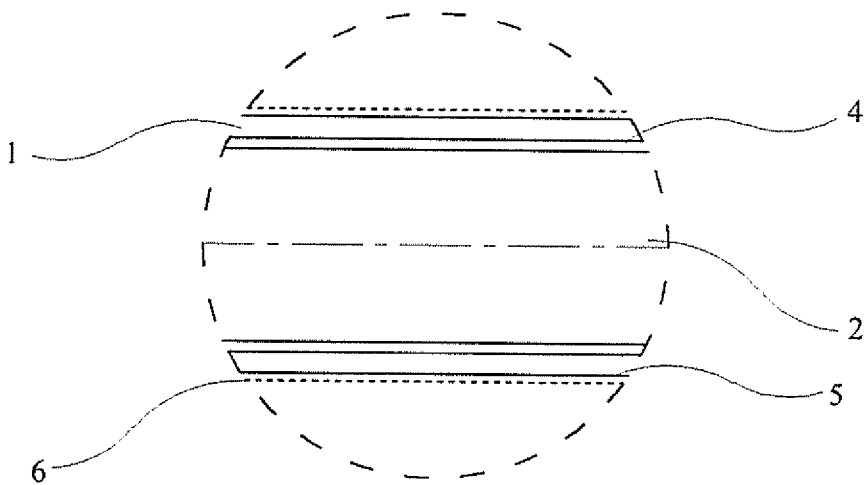

Fig. 15

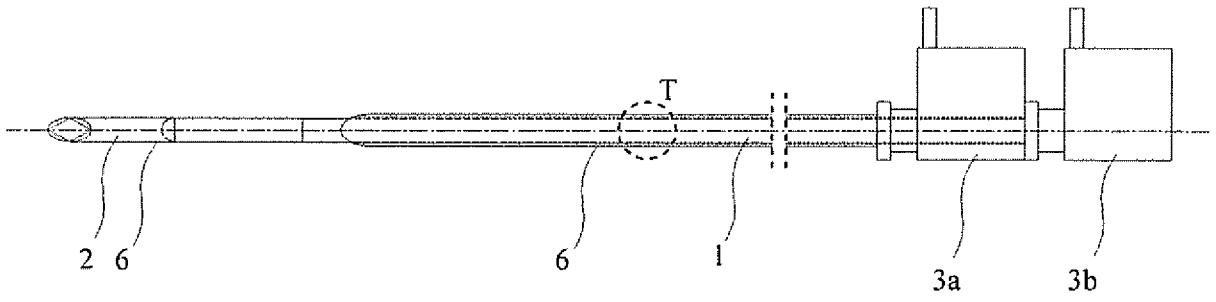

Fig. 16

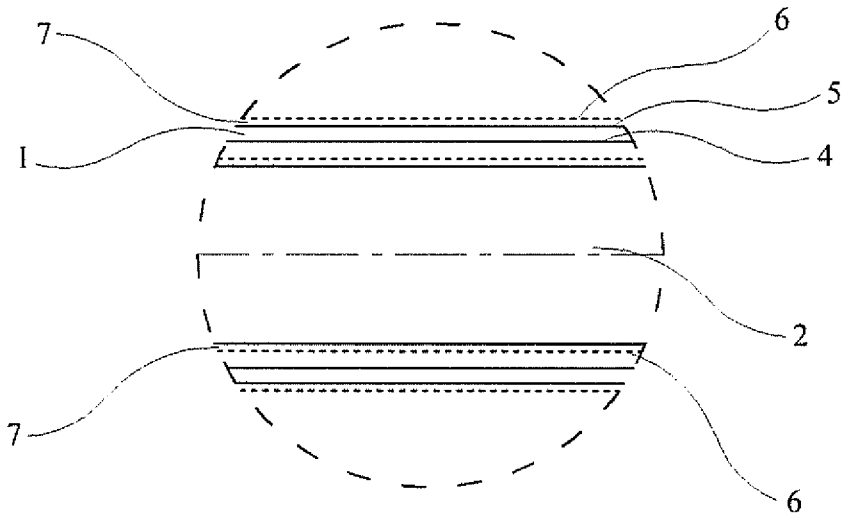

Fig. 17

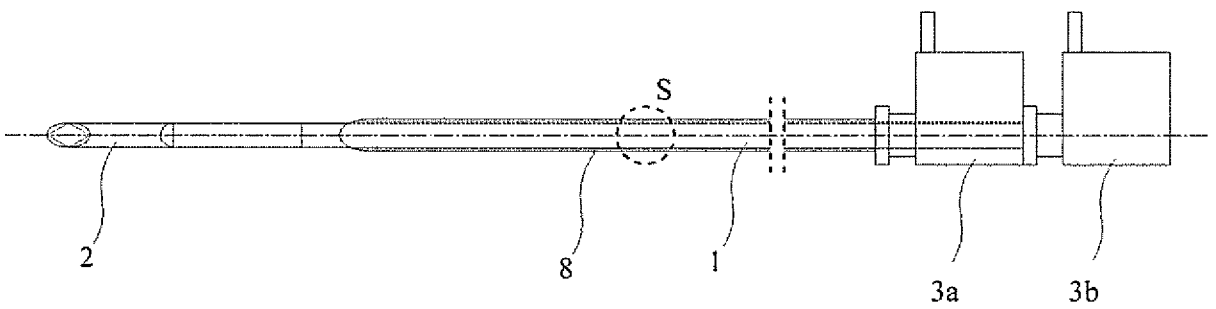

Fig. 18

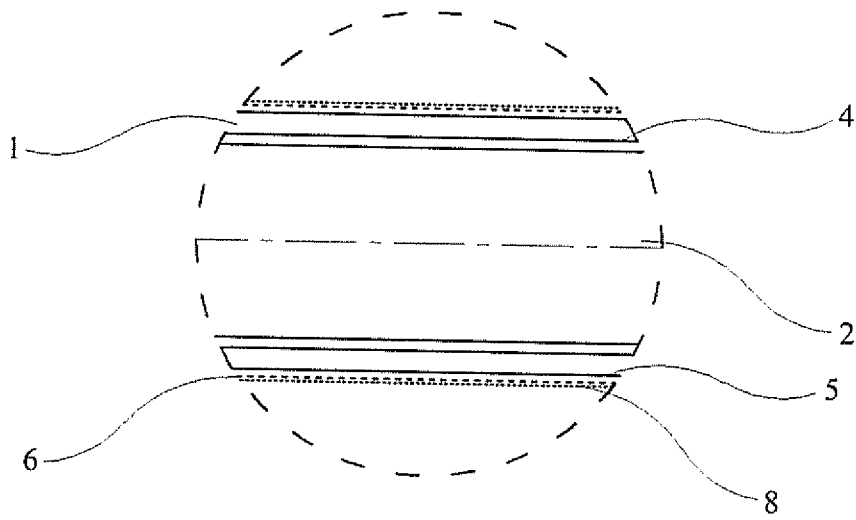

Fig. 19

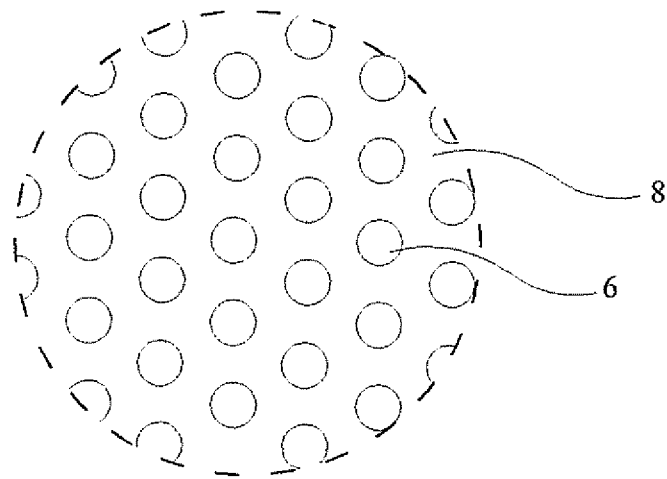

Fig. 20

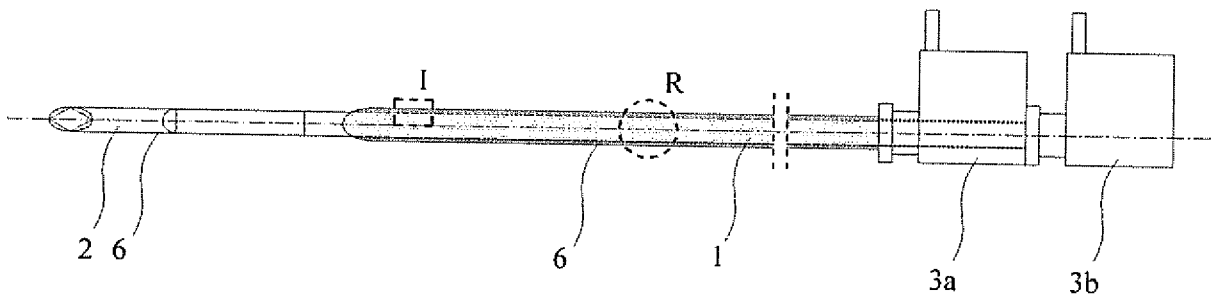

Fig. 21

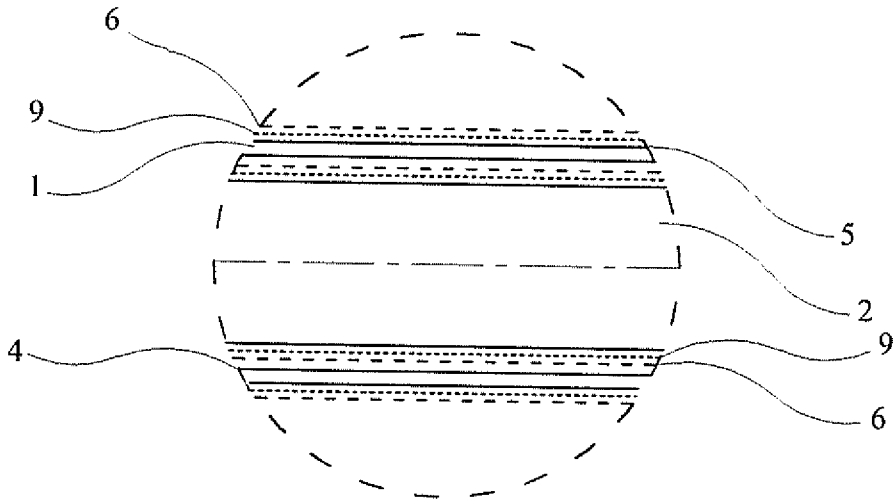

Fig. 22

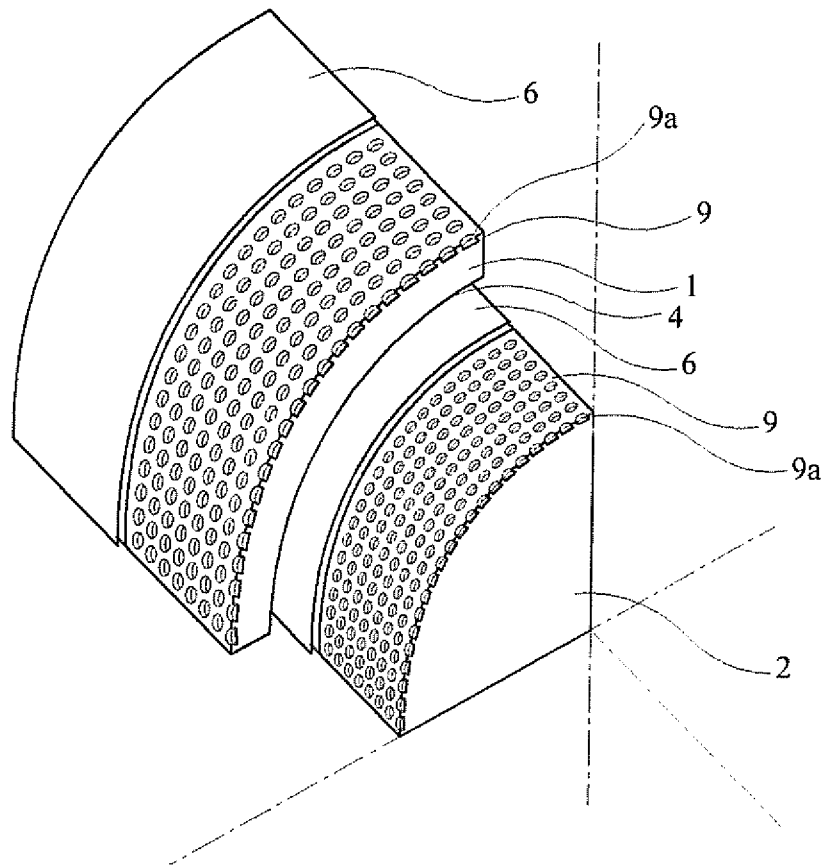

Fig. 23

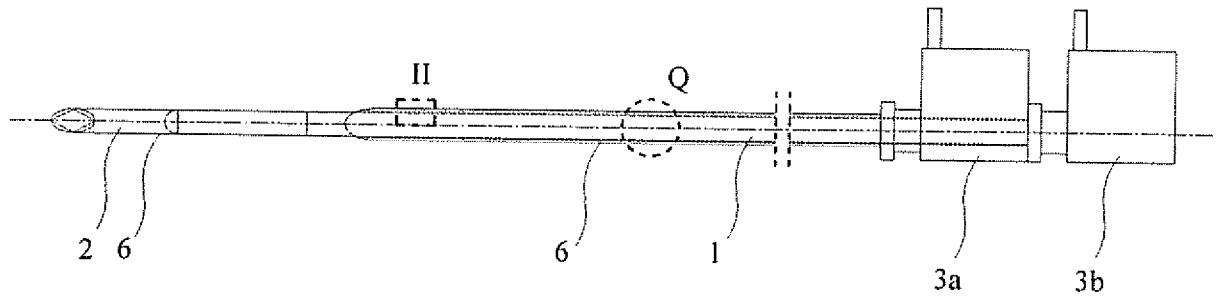

Fig. 24

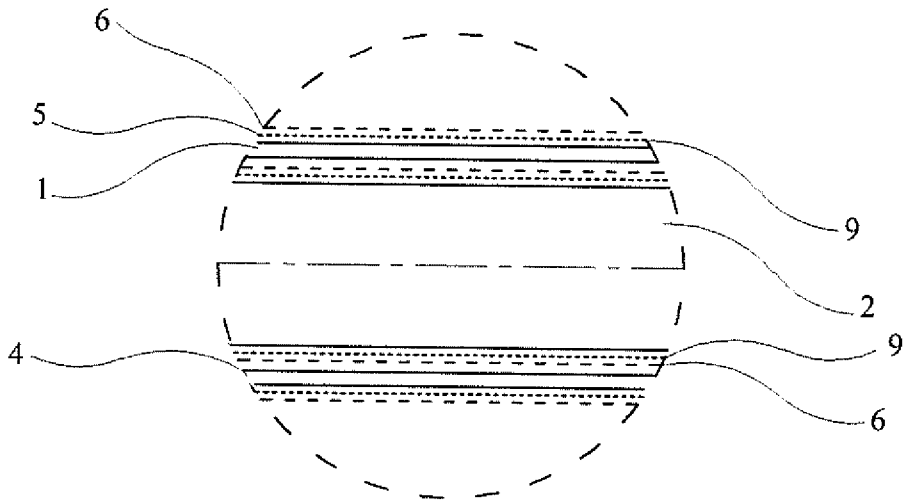

Fig. 25

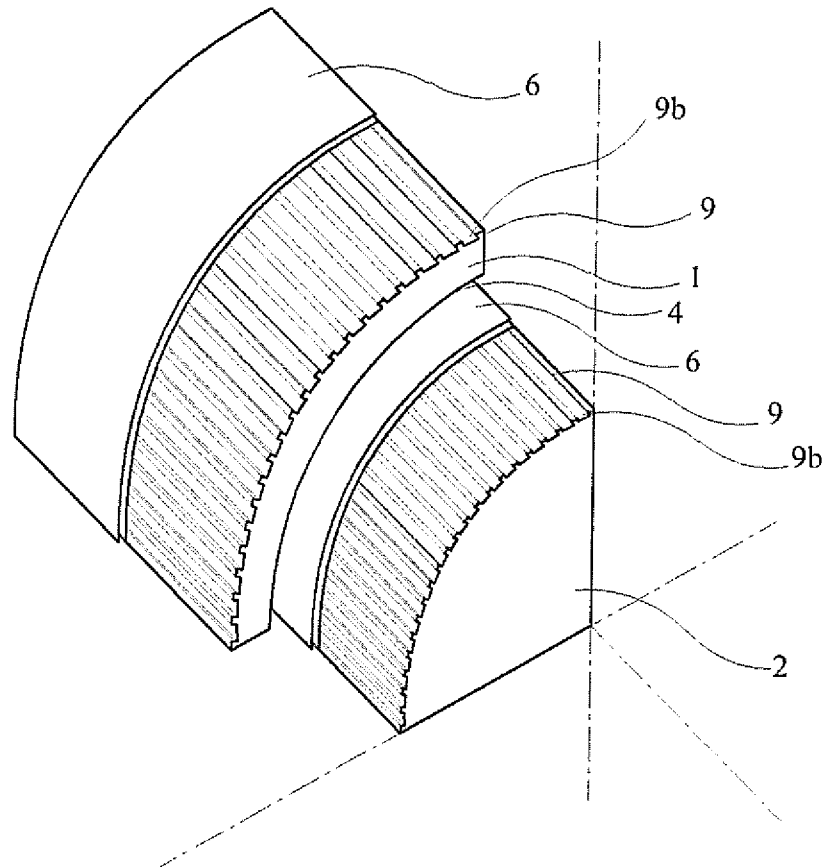

Fig. 26

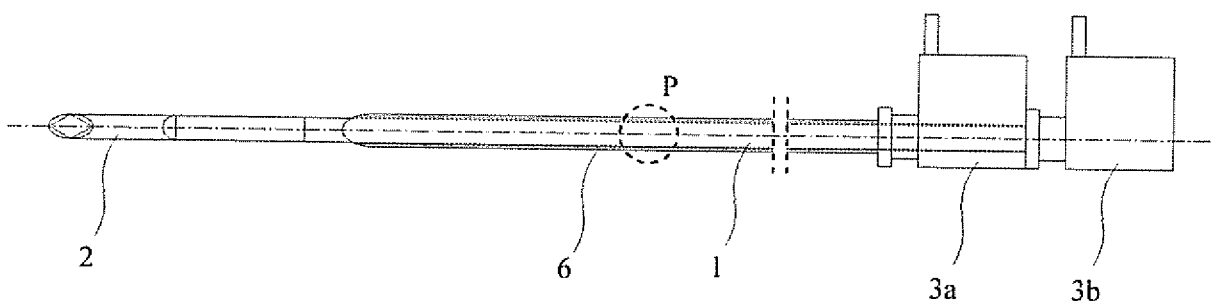

Fig. 27

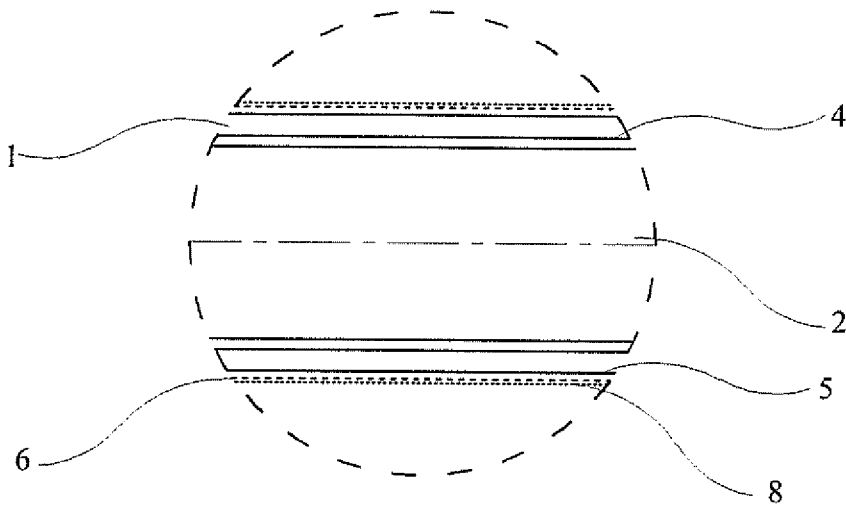

Fig. 28

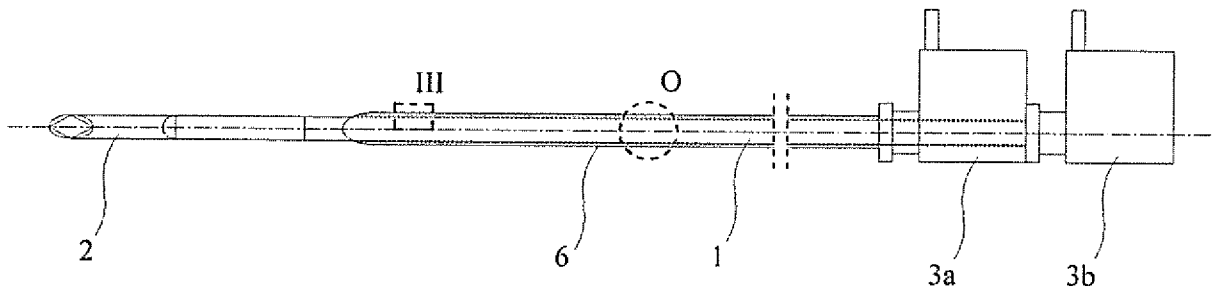

Fig. 29

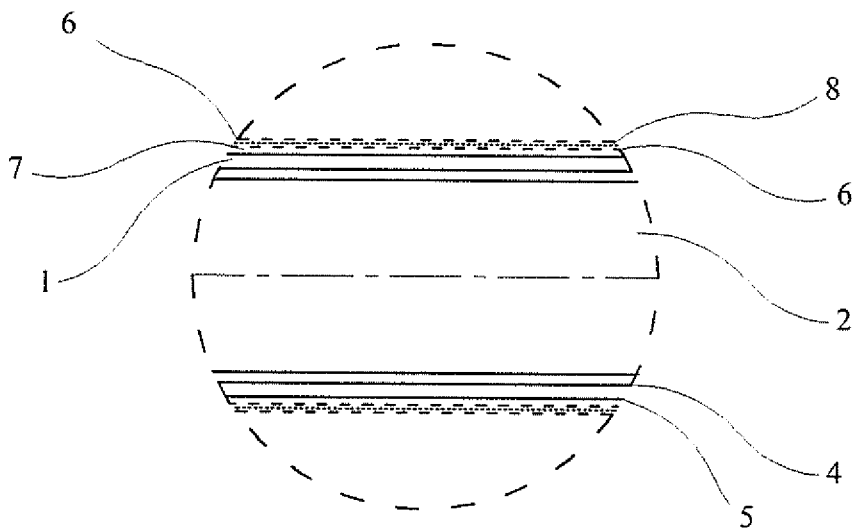

Fig. 30

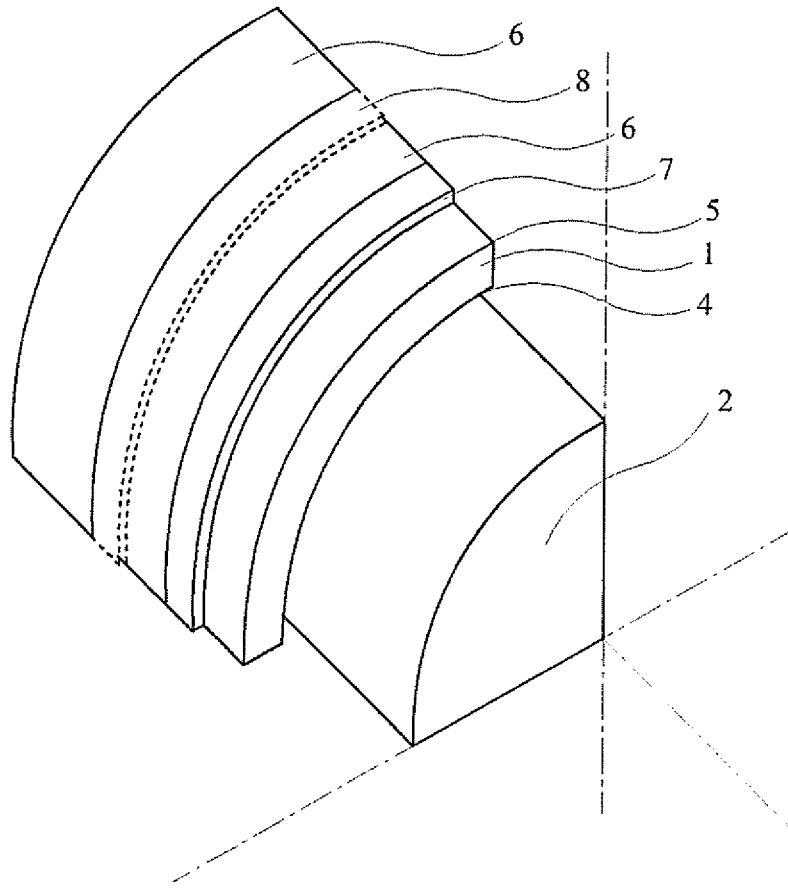

Fig. 31

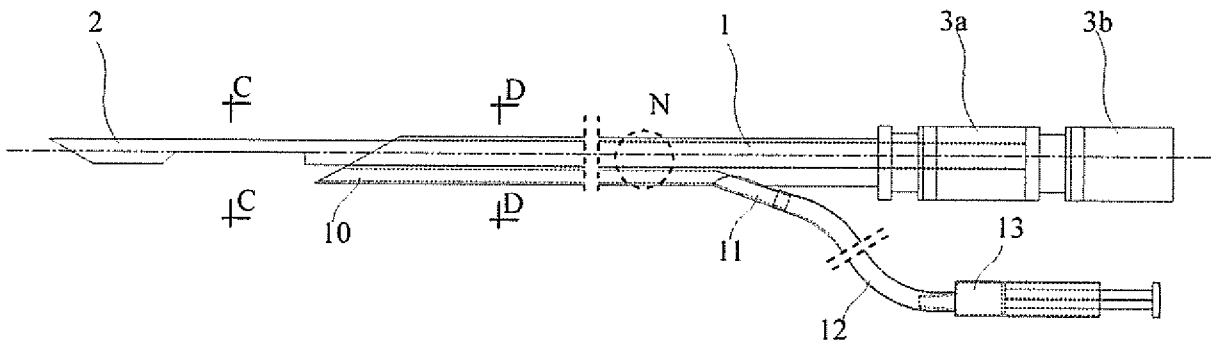

Fig. 32

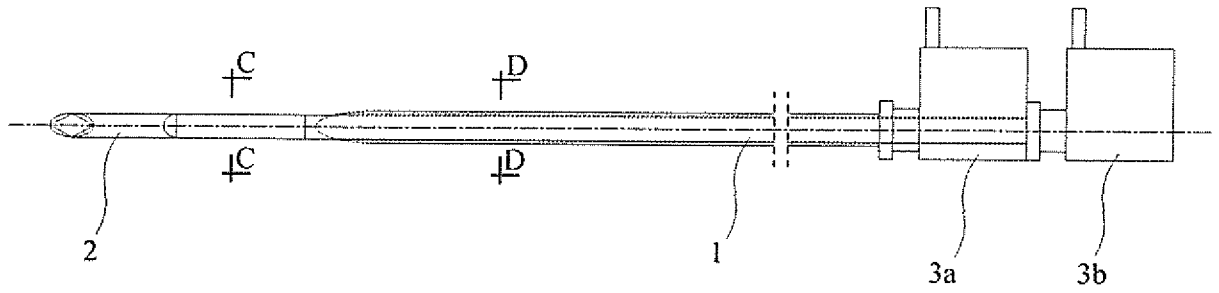

Fig. 33

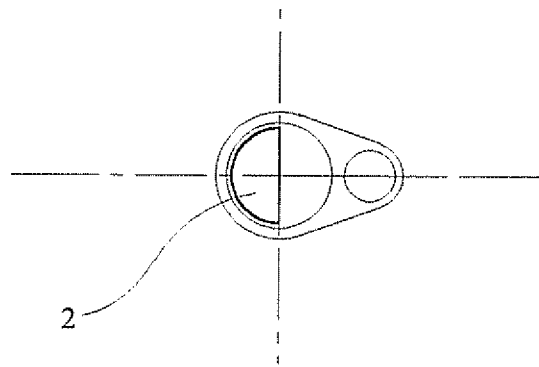

Fig. 34

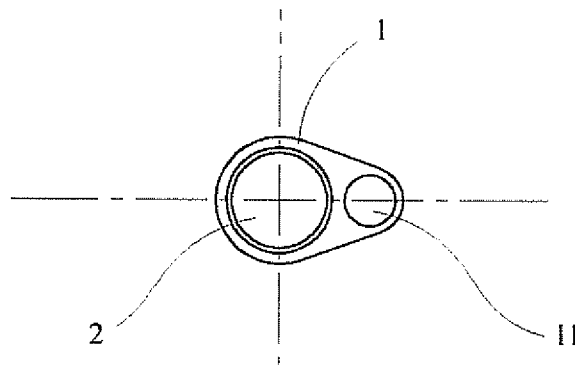

Fig. 35

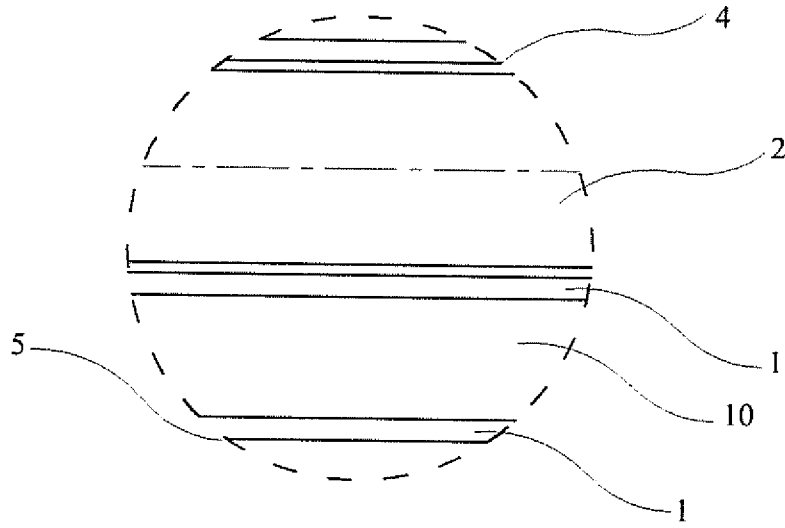

Fig. 36

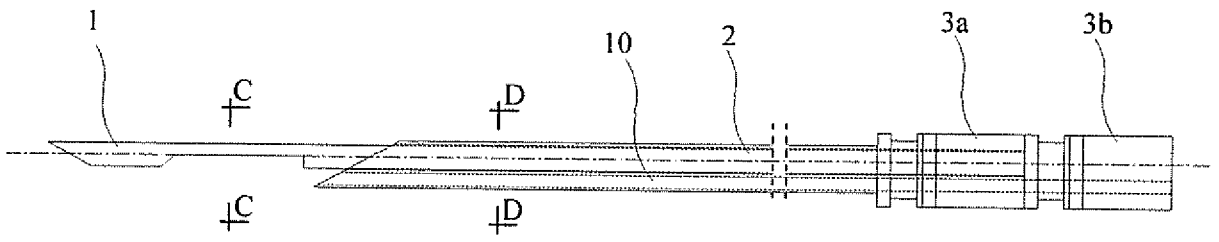

Fig. 37

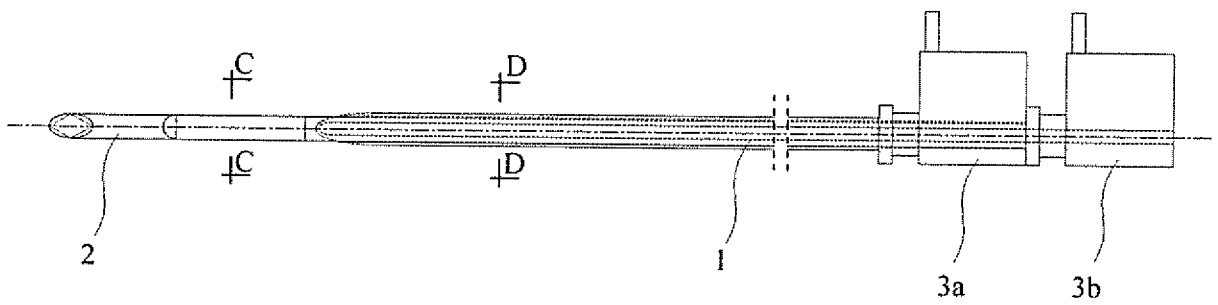

Fig. 38

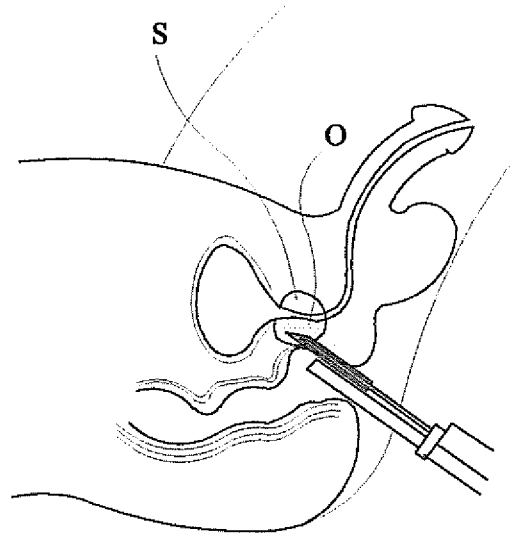

Fig. 39

