

July 28, 1936.

F. L. NOVAK

2,049,309

FUSE CARRIER

Filed Oct. 11, 1934

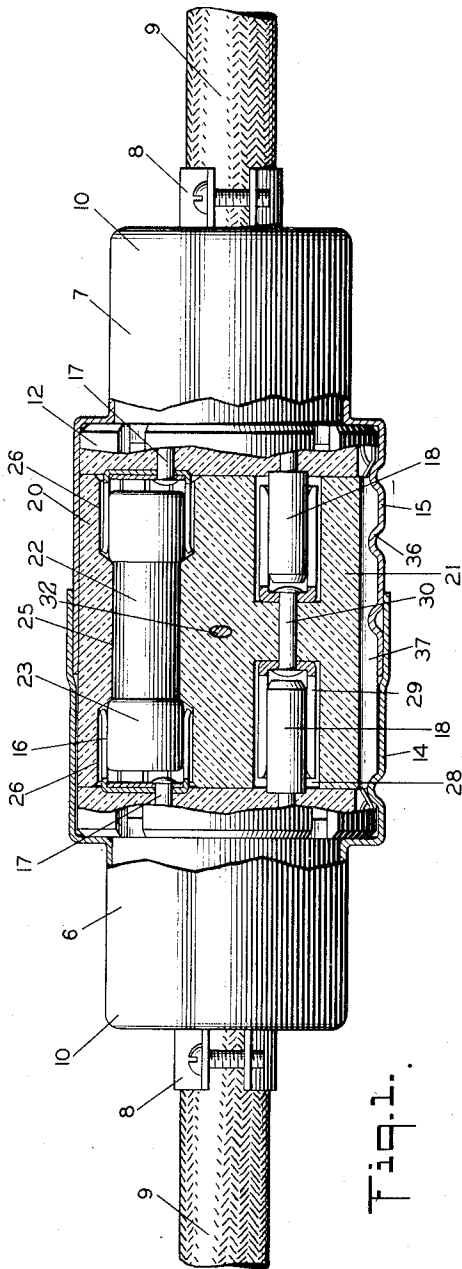

Fig. 1.

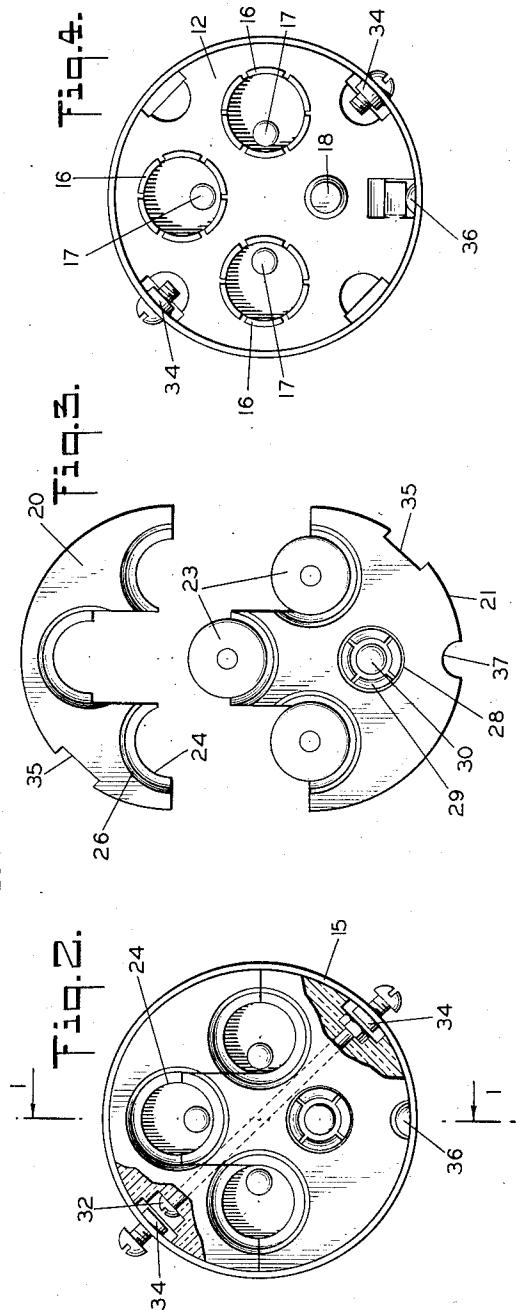

Fig. 4.

Fig. 3.

Fig. 2.

INVENTOR  
FRANK L. NOVAK  
BY HIS ATTORNEYS

*Horsell and Brown*

# UNITED STATES PATENT OFFICE

2,049,309

## FUSE CARRIER

Frank L. Novak, Maplewood, N. J., assignor to  
Russell & Stoll Company, New York, N. Y., a  
corporation of New York

Application October 11, 1934, Serial No. 747,982

25 Claims. (Cl. 200—115.5)

This invention relates to fuse carriers, and has for its main object to provide a readily removable fuse carrier whereby the carrier and its fuses may be removed and replaced as a unit, and the unit after removal may be taken apart to replace the individual fuses.

Other objects are to prevent short-circuiting of the device when it is taken apart for replacing of fuses; and to cause ground connection before fuse connection, and to insure alignment when the device is reassembled.

Other objects are to simplify and improve the construction and operation of devices of this character, as will be apparent from the following description and the accompanying drawing, in which

Figure 1 is a side elevation, largely in longitudinal section along the line 1—1 of Figure 2, of a fuse carrier according to the preferred embodiment of the preferred invention;

Figure 2 is an end elevation partly in section showing the fuse carrier as inserted in one half of the connector, the fuses being removed;

Figure 3 is an exploded end elevation of the fuse carrier; and

Figure 4 is an end elevation of one half of the connector with the fuse carrier removed therefrom.

While the invention is illustrated and described as embodied in a connector, it is obvious that the same may be embodied in a plug to cooperate with a receptacle, or in any installation in which a removable multiple fuse is desirable. The connector shown in Figure 1 comprises a pair of complementary end members 6 and 7 which are preferably of metal, and provided at their ends with strain relief fittings 8 adapted to grip the ends of cable 9. The members 6 and 7 have cup like end portions 10 within which are insulating bodies 12 for mounting the usual binding posts or the like (not shown) for receiving the conductors of the cable 9.

The end members 6 and 7 have expanded inner ends 14 and 15 comprising cup like flanges. The insulating bodies 12 extend into these flanges but terminate in flat surfaces, to which are secured fuse sockets 16, as by means of rivets 17.

As shown in Figure 4, there are a number of these fuse sockets 16, three being shown in the drawing as mounted eccentrically on the insulating body 12. The rivets 17 are eccentric with respect to the fuse sockets 16, in order to be near the center of the insulating body 12 and thus afford a stronger construction. The insulating

body 12 also has mounted therein a plug 18 which serves as a ground terminal.

The fuse carrier comprises two complementary portions 20 and 21 of molded insulating material, which fit together to form a cylindrical block adapted to fill the space within the cooperating flanges 14 and 15, between the insulating blocks 12. The fuse carrier has chambers therein adapted to receive a plurality of fuses 22 of the cartridge type. Such a fuse comprises a cylindrical body having an insulating surface, and metal end caps 23 which are of larger diameter than the body 22.

The chambers 24 in the fuse carrier have reduced central portions 25 which are adapted to grip the middle portions of the fuses. These chambers also have enlarged end portions 26 which are of greater diameter than the end caps 23, in order that these end portions 26 may not only receive the end caps 23, but may also permit entrance of the fuse sockets 16 to contact with the fuse ends 23.

The portion 21 of the fuse carrier has aligned recesses 28 therein in which are mounted ground sockets 29, adapted to receive the plugs 18. These ground sockets 29 are aligned and are held in place by a rivet 30 passing through both ground sockets.

As it is desirable to make the carrier as small as possible while containing a plurality of fuses, and as a cylindrical form is desirable, the fuse chambers are not located in the same plane. At the same time in order that the fuses may be readily removed, the fuse carrier is arranged to be parted along the longitudinal planes of the fuse chambers, as shown in Figure 3. As shown in Figure 2 the two parts of the fuse carrier are held together by a bolt or screw 32 which passes through the parts 20 and 21. The bolt or screw 32 passes through the center of the longitudinal fuse carrier but clears the chambers of the fuses and the ground connection. Thus, as the fuse carrier is molded of insulating material, the bolt or screw 32 is insulated from the connections therein.

It should be noted that the fuse carrier is longer than the fuses and that the ground sockets 29 do not extend to the outer ends of their chambers. Hence when the connector is taken apart, if the fuse carrier remaining within the flange 15 should be put down on a conducting surface, neither the fuse nor the ground socket could make contact and hence a short-circuit is impossible. Furthermore neither the fuse sockets 16 nor the ground plugs 18 extend beyond the flanges 14 and 15 so

that these parts are protected against short-circuits for the same reasons.

The ground plug 18 is longer than the sockets 16 and the ground sockets 29 are accordingly deeper than the recesses 26 which take the fuse ends 23. Hence when the fuse carrier is assembled the plug 18 will always make contact with the ground socket 29 before the fuse ends 23 can enter the sockets 16.

As shown in Figure 2 the flange 15 is provided with internal lugs 34 which cooperate with grooves 35 in the periphery of the fuse carrier. The casing 15 also has an inner lug 36 non-symmetrically arranged with respect to the lugs 34, and cooperating with groove 37 in the fuse carrier. With this arrangement the fuse carrier cannot be inserted in the flange 15 unless it is in a position to align the fuses therein with the fuse sockets on the insulating member 12, and also to insure alignment of the ground socket 29 with the ground plug 18 in the insulating member 12.

It is to be understood that the invention is not limited to the details disclosed, but instead includes such embodiments of the broad idea as fall within the scope of the appended claims.

What I claim is:

1. Fuse carrier comprising an insert adapted to receive fuses the axes of all of which do not lie in the same plane, and means for parting said insert longitudinally to expose all of said fuses for removal.

2. Fuse carrier comprising an insert having means for gripping central portions of fuses under pressure sufficient to frictionally retain the same, and insulating means extending beyond both ends of said fuses to prevent short circuit thereof by contact of the end of said carrier with a conducting surface.

3. Fuse carrier comprising an insert of insulating material having chambers adapted to receive fuses, and means for parting said insert at the axial planes of each of said chambers and at surfaces therebetween angularly disposed thereto.

4. Fuse carrier comprising an insert adapted to receive fuses the axes of which determine a plurality of planes, and means for gripping the middle portions of said fuses under pressure sufficient to prevent longitudinal removal thereof.

5. Fuse carrier comprising an insert of insulating material having chambers adapted to receive fuses, means for gripping central portions of said fuses and means for parting said insert along different planes to release said gripping means and expose said fuses for removal.

6. Fuse carrier comprising an insert of insulating material having two parts cooperating to form chambers therein transversely spaced from each other in two directions and adapted to receive fuses, said chambers having reduced portions adapted to grip the middle portions of said fuses and prevent longitudinal removal thereof.

7. Fuse carrier comprising an insert of insulating material having chambers therein adapted to receive fuses, said chambers having reduced portions adapted to grip the middle portions of said fuses under pressure sufficient to frictionally retain the same, said chambers being longer than said fuses to prevent short circuit thereof by contact of the end of said carrier with a conducting surface.

8. Fuse carrier comprising an insert of insulating material having chambers therein adapted to receive fuses, the axes of said chambers deter-

mining a cylinder, and means for parting said insert to halve each of said chambers.

9. In combination with a terminal member having sockets projecting therefrom, a fuse carrier comprising an insert of insulating material having chambers therein adapted to receive fuses, said chambers having reduced portions adapted to grip the middle portions of said fuses, and enlarged ends adapted to receive said projecting sockets to engage the ends of said fuses.

10. Fuse carrier comprising an insert consisting of a part having a recess and a part having a projection fitting the same, said recess and projection and other portions of said parts having hollows cooperating to form chambers adapted to receive fuses, means for parting said insert longitudinally to expose said fuses, and means for clamping said parts together.

11. Fuse carrier comprising an insert adapted to receive fuses, means for parting said insert asymmetrically to expose said fuses for removal and means passing through said parts and insulated thereby from said fuses for holding said parts together.

12. Fuse carrier comprising an insert having chambers, fuses and ground contacts in said insert chambers, said insert chambers having enlarged recesses associated with said ground contacts and the ends of said fuses, said enlarged ground contact recesses being deeper than said enlarged fuse end recesses.

13. In combination with a terminal member and a fuse carrier, a fuse having its central portion gripped under sufficient pressure to frictionally retain it in said carrier, a fuse socket on said terminal, said socket being adapted to engage said fuse only when said members are brought together, and means on said members for establishing a ground connection when said members with said fuse in said carrier are brought together, before said socket can engage said fuse.

14. In combination with a pair of terminal members, a fuse carrier between said members, fuses in said carrier and spaced thereby from said members, and fuse sockets permanently secured on said terminal members and projecting into said carrier and directly engaging the ends of said fuses.

15. In combination with a pair of complementary casing members each having a terminal member provided with an inner socket and an outer flange, a fuse carrier between said terminal members and separable therefrom, and a fuse in said carrier directly engaging said sockets, said flanges meeting over said carrier.

16. In combination with a terminal member having an inner eccentric socket and an outer flange, a fuse carrier adapted to enter said flange and separately supporting the middle portion of a fuse adapted to enter said socket, and cooperating means on said carrier and flange for preventing said carrier from entering said flange when said fuse is not in alignment with its socket.

17. In combination with a pair of complementary casing members each having a terminal member provided with an inner socket and an outer flange, a fuse carrier between said terminal members and separable therefrom, and a fuse in said carrier engaging said sockets, said flanges and carrier extending over said sockets and said fuses, whereby said sockets and fuses are protected from short-circuit when said casing members are disconnected.

18. In combination with a pair of terminal members each having inner sockets rigidly at-

5 tached thereto and an outer flange, said flanges cooperating to form a casing, a fuse carrier adapted to be inserted in said casing and having fuses rigidly secured therein for alignment with  
10 said sockets, whereby the ends of said fuses enter said sockets when the casing is closed.

15 19. In combination with a pair of terminal members each having inner sockets and an outer flange, said flanges cooperating to form a casing, a fuse carrier adapted to be inserted in said casing and having fuses rigidly secured therein for alignment with said sockets, whereby the ends of said fuses enter said sockets when the casing is closed, said carrier being removable with the  
20 fuses therein as a unit, and having means for releasing said fuses laterally for replacement.

25 20. In combination with a pair of terminal members each having inner sockets and an outer flange, said flanges cooperating to form a casing, a fuse carrier within said flanges and having chambers aligned with said sockets, fuses in said chambers, said chambers having inner reduced portions gripping the middle portions of said fuses, said chambers being longer than said  
30 fuses and having enlarged end portions clearing the ends of said fuses and receiving said sockets, means for parting said carrier to open said chambers to receive fuses, and means for clamping the parts of said carrier together to retain the fuses therein.

35 21. In combination with a pair of terminal members each having an inner socket and an outer flange, said flanges cooperating to form a casing, a fuse carrier within said flange, means on said fuse carrier for gripping the central portion of a fuse to hold it in alignment with

said socket, said gripping means being adapted to release said fuse laterally for replacement, said fuse carrier being longer than said fuse and having spaces at the ends of said fuse receiving said sockets.

5 22. In combination with a pair of terminal members each having sockets thereon adapted to directly receive fuse ends and flanges extending over said sockets, a fuse carrier between said terminal members carrying fuses aligned with  
10 said sockets, and means for parting said fuse carrier longitudinally to expose all of said fuses for removal.

15 23. In combination with a pair of terminal members each having sockets thereon adapted to receive fuse ends, a fuse carrier between said terminal members having means for gripping under pressure central portions of fuses aligned with said sockets, and having insulating means extending over said sockets.

20 24. In combination with a pair of terminal members each having sockets adapted to receive fuse ends, and flanges extending over said sockets, a fuse carrier divided longitudinally into non-symmetrical parts adapted to be opened and  
25 closed, and means inside said carrier for supporting fuses in alignment with said sockets.

30 25. In combination with a pair of terminal members each having sockets thereon adapted to receive fuse ends, a fuse carrier between said terminal members comprising interfitting parts having recesses cooperating to form supports for fuses aligned with said sockets, said parts being separable to release all of said fuses.

35  
FRANK L. NOVAK.