



- (51) International Patent Classification:
G01N 15/06 (2006.01)
- (21) International Application Number:
PCT/US2014/029428
- (22) International Filing Date:
14 March 2014 (14.03.2014)
- (25) Filing Language: English
- (26) Publication Language: English
- (30) Priority Data:
61/782,937 14 March 2013 (14.03.2013) US
- (72) Inventor; and
- (71) Applicant : BRUBACHER, John Miles [US/US]; 14843
Faceta Drive, La Mirada, CA 90638 (US).
- (74) Agents: SARTAIN, Jeromye V. et al.; One3 IP Manage-
ment, PC, 1113 Murfreesboro Road, Suite 106-160, Frank-
lin, TN 37064 (US).
- (81) Designated States (unless otherwise indicated, for every
kind of national protection available): AE, AG, AL, AM,
AO, AT, AU, AZ, BA, BB, BG, BH, BN, BR, BW, BY,
BZ, CA, CH, CL, CN, CO, CR, CU, CZ, DE, DK, DM,
DO, DZ, EC, EE, EG, ES, FI, GB, GD, GE, GH, GM, GT,
HN, HR, HU, ID, IL, IN, IR, IS, JP, KE, KG, KN, KP, KR,

KZ, LA, LC, LK, LR, LS, LT, LU, LY, MA, MD, ME,
MG, MK, MN, MW, MX, MY, MZ, NA, NG, NI, NO, NZ,
OM, PA, PE, PG, PH, PL, PT, QA, RO, RS, RU, RW, SA,
SC, SD, SE, SG, SK, SL, SM, ST, SV, SY, TH, TJ, TM,
TN, TR, TT, TZ, UA, UG, US, UZ, VC, VN, ZA, ZM,
ZW.

- (84) Designated States (unless otherwise indicated, for every
kind of regional protection available): ARIPO (BW, GH,
GM, KE, LR, LS, MW, MZ, NA, RW, SD, SL, SZ, TZ,
UG, ZM, ZW), Eurasian (AM, AZ, BY, KG, KZ, RU, TJ,
TM), European (AL, AT, BE, BG, CH, CY, CZ, DE, DK,
EE, ES, FI, FR, GB, GR, HR, HU, IE, IS, IT, LT, LU, LV,
MC, MK, MT, NL, NO, PL, PT, RO, RS, SE, SI, SK, SM,
TR), OAPI (BF, BJ, CF, CG, CI, CM, GA, GN, GQ, GW,
KM, ML, MR, NE, SN, TD, TG).

Declarations under Rule 4.17:

- of inventorship (Rule 4.17(iv))

Published:

- with international search report (Art. 21(3))
- before the expiration of the time limit for amending the
claims and to be republished in the event of receipt of
amendments (Rule 48.2(h))

(54) Title: SAMPLE ACQUISITION SYSTEM AND METHOD OF USE

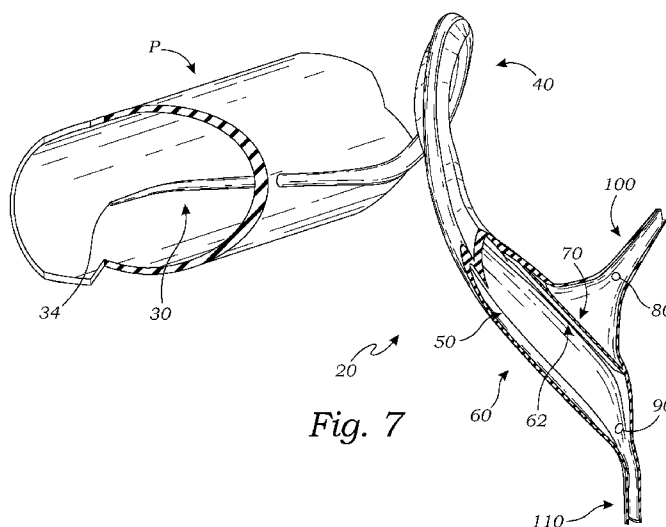

Fig. 7

(57) Abstract: A system for acquiring a fluid sample from a flow pipe, comprising a sampling probe placed within the flow pipe, a curved separating pipe in fluid communication with the sampling probe, the separating pipe having formed therein an inwardly-opening lengthwise channel along the outside curve thereof, the separating pipe terminating in a sample area, and a lengthwise inwardly-opening sample passage in fluid communication between at least a portion of the sample area and a sample port, the sample passage being formed substantially opposite the channel, whereby inertial effects induced in the separating pipe cause relatively higher density inorganic and dead organic material to funnel into the channel and out a non-sample drain formed in the sample area substantially opposite the separating pipe while allowing live organisms to navigate the sample passage and out the sample port.



DESCRIPTIONSAMPLE ACQUISITION SYSTEM AND METHOD OF USE

5 RELATED APPLICATIONS:

[0001] This application claims priority and is entitled to the filing date of U.S. Provisional application Ser. No. 61/782,937 filed March 14, 2013, and entitled "Sample Acquisition System and Method of Use." The contents of the aforementioned application are incorporated herein by
10 reference.

INCORPORATION BY REFERENCE:

[0002] Applicant(s) hereby incorporate herein by reference any and all patents and published
15 patent applications cited or referred to in this application.

TECHNICAL FIELD:

[0003] Aspects of this invention relate generally to sampling systems, and more particularly
20 to sample acquisition systems and methods of use relating to obtaining a fluid sample from a fluid flow.

BACKGROUND ART:

[0004] By way of background, a number of industries are affected by regulations relating to
25 water treatment, such as ballast water treatment systems ("BWTS") on ships and the like. Such regulations require that microorganisms be effectively rendered non-viable or non-living by the BWTS before such water is returned to the ocean or other body of water. Generally speaking, Zooplankton in the size range of approximately 10 to 50 microns or larger can be the
30 "indicator" microorganism used to determine the effectiveness of treatment. Phytoplankton below 50 microns has also been employed as the indicator organism. To date, monitoring the effectiveness of such BWTS has largely been handled through samples submitted to a lab, there

- 2 -

most often involving human examination under a microscope, and the samples themselves being obtained “off-line” as in a collection tank and then having a delay from the sample acquisition event to any manipulation or evaluation of the sample. As such, these laboratory approaches to sample acquisition and compliance assessment have numerous shortcomings in terms of accuracy, speed, and cost. Similarly, flow cytometry systems can offer relatively higher throughput, but not necessarily for real time direct enumeration of live vs dead zooplankton levels, due to a significant amount of man-in-the-loop sample preparation. Fundamentally, neither such prior art approaches provide a mechanism for sorting living organisms from non-living or inorganic matter within the sample as part of the acquisition system or otherwise in an automated form in “real time” or through “on-line” sampling from a fluid flow. The present invention improves and renders deployable the sample acquisition process in meeting these needs and provides further advantages over prior art sampling systems and approaches. The subject invention, though again in the context of BWTS compliance testing, may be practiced in a wide array of contexts and so is not limited to the exemplary BWTS context (for example, ocean, lake, river and stream testing as well as air or other fluid testing). Thus, while “water” is discussed throughout as the sampled fluid, it is to be understood that the invention is not so limited and other fluids may be sampled as well, again depending on the context.

DISCLOSURE OF INVENTION:

20

[0005] Aspects of the present invention teach certain benefits in construction and use which give rise to the exemplary advantages described below.

25

[0006] The present invention solves the problems described above by providing a new and novel system and method for acquiring a fluid sample from a flow pipe. The system provides, in the exemplary embodiment, a sampling probe placed within the flow pipe, a curved separating pipe in fluid communication with the sampling probe, the separating pipe having formed therein an inwardly-opening lengthwise channel along the outside curve thereof, the separating pipe terminating in a sample area, and a lengthwise inwardly-opening sample passage in fluid communication between at least a portion of the sample area and a sample port, the sample passage being formed substantially opposite the channel, whereby inertial effects

30

- 3 -

induced in the separating pipe cause relatively higher density inorganic and dead organic material to funnel into the channel and out a non-sample drain formed in the sample area substantially opposite the separating pipe while allowing live organisms to navigate the sample passage and out the sample port.

5

[0007] A primary objective inherent in the above described system and method of use is to provide advantages not taught by the prior art.

10 [0008] Another objective is to provide such a system and method wherein the separating pipe is substantially helically curved, in at least one embodiment.

[0009] Another objective is to provide such a system and method wherein the sample passage is formed having a blocking chute suspended therein, in at least one embodiment.

15 [0010] Another objective is to provide such a system and method wherein an attractant is positioned within the sample area substantially adjacent the sample passage or the sample port, in at least one embodiment.

20 [0011] Another objective is to provide such a system and method wherein a repellant is positioned within the sample area substantially adjacent the non-sample drain, in at least one embodiment.

[0012] Another objective is to provide such a system and method wherein the sampling probe is an isokinetic probe, in at least one embodiment.

25

[0013] Another objective is to provide such a system and method wherein a bubble collapsing screen is positioned within the flow pipe upstream of the distal sampling tip orifice.

30 [0014] Other features and advantages of aspects of the present invention will become apparent from the following more detailed description, taken in conjunction with the accompanying drawings, which illustrate, by way of example, the principles of aspects of the invention.

- 4 -

BRIEF DESCRIPTION OF DRAWINGS:

[0015] The accompanying drawings illustrate aspects of the present invention. In such drawings:

5

[0016] Figure 1 is a schematic view of an exemplary sample acquisition system, in accordance with at least one embodiment;

10

[0017] Figure 2 is an enlarged schematic sectional view thereof taken along line “2-2” of Fig. 1, in accordance with at least one embodiment;

[0018] Figure 3 is an enlarged schematic sectional view thereof taken along line “3-3” of Fig. 1, in accordance with at least one embodiment;

15

[0019] Figure 4 is an enlarged partial schematic sectional view thereof taken from circle “4” of Fig. 3, in accordance with at least one embodiment;

[0020] Figure 5 is a perspective view of an alternative exemplary sample acquisition system, in accordance with at least one embodiment;

20

[0021] Figure 6 is a further perspective view thereof, in accordance with at least one embodiment;

25

[0022] Figure 7 is a further, partially cut-away perspective view thereof, in accordance with at least one embodiment;

[0023] Figure 8 is an enlarged, partial, sectioned perspective view thereof taken along line “8-8” of Fig. 5, in accordance with at least one embodiment;

30

[0024] Figure 9 is a further enlarged, partial, sectioned schematic view thereof taken from circle “9” of Fig. 8, in accordance with at least one embodiment;

- 5 -

[0025] Figure 10 is a schematic view of the alternative exemplary sample acquisition system of Fig. 5, in accordance with at least one embodiment;

[0026] Figure 11 is an enlarged schematic sectional view thereof taken along line "11-11" of Fig. 10, in accordance with at least one embodiment;

[0027] Figure 12 is an enlarged schematic sectional view thereof taken along line "12-12" of Fig. 10, in accordance with at least one embodiment; and

[0028] Figure 13 is an enlarged partial schematic sectional view thereof taken from circle "13" of Fig. 12, in accordance with at least one embodiment.

[0029] The above described drawing figures illustrate aspects of the invention in at least one of its exemplary embodiments, which are further defined in detail in the following description. Features, elements, and aspects of the invention that are referenced by the same numerals in different figures represent the same, equivalent, or similar features, elements, or aspects, in accordance with one or more embodiments.

MODES FOR CARRYING OUT THE INVENTION:

20

[0030] The above described drawing figures illustrate aspects of the invention in at least one of its exemplary embodiments, which are further defined in detail in the following description.

[0031] As an overview, and with reference to the schematic view of Fig. 1, the exemplary sample acquisition system **20** has eight main hardware components or sections, which are discussed in turn below: a sampling probe **30** installed in a flow pipe **P**; a separating pipe **40** having a first cross-section as shown in Fig. 2; a channel **50** of the separating pipe **40** in which are incorporated particle returns **52**, **53**, **54** and **55**; a sample area **60** of the separating pipe **40** having a second cross-section as shown in Fig. 3; a sample blocking chute **70**; attractants **80** and/or repellants **90**; a sample port **100**; and a non-sample drain **110**. There are related tanks, tubes, filters, pumps, and other aspects, whether or not shown, that may facilitate the collection

30

- 6 -

and processing of the water sample, which could be necessary in particular contexts but are nevertheless ancillary components that can be substituted for by other equivalent structure now known or later developed and so are not the focus of the present invention. It will be appreciated by those skilled in the art that the exact configuration of the system and its eight
5 main sections or features may take a number of forms to suit particular applications without departing from the spirit and scope of the present invention. Accordingly, it will be further appreciated that the configurations of the system shown and described are exemplary and that the invention is not so limited. Features, elements, and aspects of the invention that are referenced by the same or similar names or numerals or depicted in similar fashion in different
10 views represent the same, equivalent, or similar features, elements, or aspects, in accordance with one or more embodiments.

[0032] Turning now to Fig. 1, there is shown a schematic side view, not to scale, of an exemplary embodiment of a sample acquisition system **20** according to aspects of the present
15 invention. Going in sequence as a water sample would be obtained and processed through the system **20**, and thus starting upstream of the sampling probe **30**, an illustrative flow pipe **P** cross-section having a flow therethrough from left to right in the schematic is shown as having a pipe fluid velocity profile **V** therein (though shown downstream of the sampling probe **30** for ease of illustration, it will be appreciated that such velocity profile would be substantially
20 consistent along such a pipe of roughly consistent dimension and inner surface), which velocity profile **V** those skilled in the art will appreciate is dictated by a number of factors such as the pipe diameter and inner surface characteristics and the kind of fluid passing therethrough. The sampling probe **30** is identified in the exemplary embodiment as “isokinetic,” which is generally a term of art relating to sampling of a fluid stream at substantially the same rate at which the
25 stream is approaching the sample nozzle (i.e., that the velocity or flow rate of the sample acquisition flow is substantially the same as that of the flow being sampled), which is beneficial in providing a representative sample particularly where particulates are carried in the fluid stream. It will be appreciated by those skilled in the art that the sampling probe **30** may or may not be “isokinetic” in the strictest sense, such that the present invention is not so limited, though
30 the principle of isokinetic sampling has nevertheless been taken into account in the selection or configuration of the sampling probe **30** and the overall sample acquisition system **20**. As

- 7 -

shown, the sampling probe **30** is effectively positioned within the flow pipe **P** such that a distal end **32** thereof defining the intake tip or inlet or sampling orifice **34** of the probe **30** is substantially parallel to the fluid flow or the walls of the flow pipe **P** and is further positioned substantially centered therein, or substantially along the centerline or axis of the flow pipe **P** where it will be appreciated is typically the location of maximum fluid velocity. In order to support lower frictional losses, the inside cross-sectional area of the sampling probe **30** will be increased or tapered so that the fluid velocity of the sample will be decreased for the majority of the length of the probe **30**, which increase in cross-section will occur gradually enough in order to not generate too much turbulence within the probe. In the exemplary embodiment the sampling orifice **34** has an inside diameter of approximately 4 mm tapering gradually to a sampling probe inside diameter of approximately 20 mm, though it will be appreciated that virtually infinite variations on such dimensions are possible. The tip of the probe **30** will preferably maintain the required velocity for only a short distance, such that in the exemplary embodiment its length is only approximately three (3) inside diameters. A control system (not shown) will maintain the proper sampling flow relative to the fluid velocity in close proximity to the sampling probe **30**, preferably substantially the same, slightly greater or slightly less than the local fluid velocity. As such, a local velocity sensor (not shown) may be operably installed integral to or substantially adjacent to the sampling probe **30**, such as near the tail end of the sampling probe **30**, which velocity sensor will preferably have a design or profile that will eliminate or reduce any significant turbulence that could impact the integrity of the velocity data from the sensor or the representative sampling characteristics of the isokinetic probe. In order to maintain adequate probe performance with minimal maintenance, forward mounted devices may be installed within the flow pipe **P** to protect the sampling probe **30** from possible conditions found in the pipework. For example, a debris screen **36** may be installed in the flow pipe **P** upstream of the sampling probe inlet **34** so as to deflect or trap larger objects and so deter them from hitting the probe **30**. Such a debris screen **36** may be on the order of 10 mm mesh. A bubble collapsing screen **38** may also be provided, illustrated as positioned between the debris screen **36** and the sampling probe inlet **34**, for the purpose of mitigating the effects bubbles might have on sample integrity and so having on the order of a 2 mm mesh size, for example. Such screens **36**, **38** may be suspended within the pipe **P** using any mounting means now known or later developed, though preferably having a relatively small and streamlined

- 8 -

profile so as to minimize any disturbance to or creation of turbulence in the fluid flow. In the exemplary embodiment, the sampling probe **30** beyond the inlet or intake section then bends substantially ninety degrees (90°) so as to extend perpendicular to the flow and pass through the wall of the flow pipe **P** as shown. Those skilled in the art will appreciate that all such exemplary configurations and dimensions are merely illustrative of aspects of the present invention and non-limiting. Rather, any such flow pipe and sampling probe configurations now known or later developed may be practiced in conjunction with the present invention without departing from its spirit and scope.

10 [0033] Turning next to the separating pipe **40**, it is shown as being in fluid communication with the proximal end **31** of the sampling probe **30** and as being generally configured having a gradually expanding and curving profile, more about which will be said and appreciated from the below discussion. In principle, the separating pipe **40** is to be configured to decelerate or slow the sample and so allow any relatively higher density inorganic and dead organic material suspended in the fluid sample to be separated from that portion of the fluid sample containing any relatively lower density live microorganisms. The primary velocity vector in the separating pipe **40** is towards the outside of the curve, which causes the relatively higher density material to travel along the outside curve of the separating pipe **40**, or that portion of the pipe generally to the left as shown in the schematic, which thus defines an outside channel **50** along the separating pipe **40**. In contrast, due to a greater drag-to-mass ratio, among other things, the relatively lower density live and more buoyant microorganisms would tend to move towards the relatively lower velocity inside of the curve, or that portion of the separating pipe **40** generally to the right as shown in Fig. 1. To enhance this process, in the exemplary embodiment, the inside of the curve may be formed of or coated or otherwise treated so as to have a relatively higher friction surface and the outside of the curve to have a relatively lower friction surface. The result in one aspect of the invention, then, is a curve of the separating pipe **40** defining a velocity profile that has a relatively greater velocity closer to the outside of the curve. With reference to the separating curve cross-section shown in Fig. 2, which would be representative of the upper section of the separating pipe **40** between the sampling probe **30** and the sample area **60**, more about which is said below, it is to be appreciated that the separating pipe **40** upper portion is in the exemplary embodiment effectively tapered from the sampling probe **30** to the

- 9 -

sample area **60**, such that the cross-section of Fig. 2 is to be understood as merely illustrative, it being further noted once more that the schematic is not to scale. In the exemplary embodiment of the separating curve upper cross-section, integral to the shape of the separating pipe **40** is a particle channel **50** on the outside of the curve as shown, which channel helps direct the higher velocity flow that may contain inorganic and dead organic matter toward the non-sample drain **110**. The cross-section has a substantially “triangular” or “wedge” shape on the inside of the curve that provides an overall larger surface area and thus greater frictional area to facilitate lower fluid velocity, which surfaces may again be relatively higher-friction as well. Opposite the “triangular” profile inside curve of the separating pipe **40** there is shown a “dome” shape towards the outside of the curve that facilitates “focusing” the relatively higher density particles to the outside of the curve that may then be “captured” by the particle channel **50**, which “domed” surface and the particle channel **50** itself may again be relatively low-friction. In this way, the flow containing a relatively higher concentration of relatively higher density inorganic and dead organic material is accelerated to the outside of the separating pipe **40**, and the separating curve cross-section, specifically, so as to pull or sweep such fluid and material downwardly toward the non-sample drain **110**.

[0034] With continued reference to Fig. 1 and now with reference to the enlarged section view of Fig. 3, the flow so divided or beginning to separate then passes out of or transitions from the separating pipe **40** into the sample area generally denoted **60** shown in the schematic as substantially at the bottom of the system **20**, or downstream of the separating pipe **40**. Integral to the sample area **60** is the continued separation between the relatively higher and lower density material wherein the overall velocity in this section is relatively low, such that any frictional losses are not significant, and the particle channel **50** formed at the outer curve continues to separate the higher density non-living particles, while the live organisms are drawn into or swim toward the “safety” of the inner sample passage **62**, more about which is said below. As shown in Fig. 3, the sample area **60** has an exemplary cross-section wherein the particle channel **50** is still formed substantially at the outside curve of the profile, only now that outside curve having transitioned in the exemplary embodiment from a “dome” shape as in the separating pipe **40** into more of an inverted triangle opening toward the substantially opposite sample passage **62**, so as to effectively funnel the relatively higher density dead or inorganic

- 10 -

matter in the sample flow down into the channel **50** and away from the sample passage **62** and ultimately out through the non-sample drain **110**. More particularly, in a further exemplary aspect of the invention, the particle channel **50** is formed having one or more particle returns **52**, **53**, **54**, and **55**, each of which functionally provides an effective trap and feeds a particle return
5 line **56** as a means for the particles to bypass all or part of the sample area **60** altogether. It will be appreciated that any such structure and associated function of the particle channel **50** spanning one or both of the separating pipe **40** and the sample area **60** for the purpose of separating and readily flowing the sample containing proportionately higher dead or inorganic particles may be employed in the present invention without departing from its spirit and scope.
10 In the exemplary embodiment, the schematic again not being to scale, the distance across the sample area **60** is approximately fifty to two hundred millimeters (50-200 mm), though this will be appreciated as merely illustrative.

[0035] Referring still to Figs. 1 and 3, attention is next drawn to the sample intake passage **62**
15 and associated blocking chute **70**, which together facilitate separation out of the flow of the relatively lower density live organisms “swimming” around the chutes as they resist downward movement while the relatively higher density dead organisms and inorganic material is channeled down to the bottom and out. Particularly, it is expected that the more buoyant organic material will move through the sample passage **62** and around the blocking chute **70** as
20 the buoyancy force vector resists going down the chutes. A significant characteristic of the sample area **60** that facilitates these functions is low velocity of the fluid, particularly in and around the sample passage **62** and the sample blocking chute **70**. This will minimize any forces generated as the fluid moves around the chute **70**, requiring self-induced or buoyant forces for successful negotiation around the obstructions. In the exemplary embodiment, the sample
25 blocking chute **70** is effectively shaped so as to be narrow enough to allow live microorganisms to easily bypass the chute **70**, wide enough to effectively guide the higher density material down to the bottom of the sample area **60**, and long enough to both capture and guide higher density material to the non-sample drain **110** at the bottom. Such a “drop chute” system will not necessarily be one hundred percent effective, but the “chutes” – both the sample blocking chute
30 **70** and the outer channel **50** – are nevertheless effective in minimizing the transportation of inorganic or dead organic material into the sample analysis system (not shown). With reference

- 11 -

again to the cross-sectional view of Fig. 3 and now the further enlarged cross-sectional view of Fig. 4 representative of the sample blocking chute **70**, by way of further explanation regarding the exemplary embodiment, the sample passage **62** may be configured to effectively form a “non-linear path,” or a flow path around the central blocking chute **70** only readily navigated by living organisms, as by leaving a gap or space between the edges of the blocking chute **70** and the interior sample passage surface **68**. This is further accomplished in the illustrated embodiment by forming an opening or inlet **66** in the sample passage **62** as defined by opposing sample passage lips **64** that is narrower than the blocking chute **70** is wide, such that, as shown, dead or non-organic particles, which generally only move in a straight line and are non-motive, may be deflected off of the surfaces or lips **64** around the inlet **66** or off of the concave inwardly-facing surface **72** of the blocking chute **70** and back into the sample area **60**, or effectively down the sample area **60** along the blocking chute **70** toward the non-sample drain **110**, while once again live organisms, which are to some extent motive, or exhibit self-induced motion, and are subject to buoyancy forces and can thus move in non-straight lines, would tend to move around an obstacle such as the blocking chute **70** and thus pass through the sample passage **62** and on to the sample port **100** as shown. In the exemplary embodiment, the blocking chute has a substantially convex or sloped outwardly-facing surface **74** opposite the inwardly-facing surface **72** and the sample port **100** tapers down or has a progressively reduced inside diameter or dimension so as to speed the flow back up therethrough.

20

[0036] The sample port **100** is effectively the inlet to the microorganism analysis section (not shown), which may be any appropriate such testing or analysis device or system now known or later developed, including but not limited to the “Microorganism Evaluation System” disclosed in a co-pending international PCT patent application filed by the same inventor on June 18, 2013, and assigned Int’l. App. No. PCT/US2013/046334, which itself claims priority to a U.S. provisional patent application filed on June 18, 2012, and assigned Serial No. 61/661,011. Additional details regarding such an analysis system are further disclosed in co-pending U.S. provisional patent applications by the same inventor entitled “Microorganism Evaluation System Viewing Section” filed on December 16, 2013, and assigned Serial No. 61/916,343, and entitled “Microorganism Sorting System and Method” filed on January 24, 2014, and assigned Serial No. 61/931,412. Within or in front of the sample port **100** substantially upstream of any

30

- 12 -

such microorganism analysis section, a wire mesh (not shown) may be located in order to prevent larger material from obstructing the analysis section. Again, the only other passage out of the system **20** is effectively the non-sample drain **110** at the bottom, where the water or other fluid containing substantially higher amounts of dead or inorganic material passes from the system **20**. The pump (not shown) that supports this section will be able to pass the particulate material that collects down in this portion of the system **20**, or that passes through the non-sample drain **110**. Furthermore, the control system will vary the flow rate out through the drain **110** in order to indirectly, though effectively, meet the sample flow requirements going out through the sample port **100**, as it will be appreciated that the flow rate through one will affect the flow rate through the other within this effectively closed system. In one embodiment, for at least this purpose of regulating flows, a fluid velocity sensor (not shown) may be located in the tube (not shown) downstream of the sample port **100** in order to measure the sample flow rate and provide such feedback to the control system. In the exemplary embodiment, with the flows out of the sample port **100** and the non-sample drain **110** so regulated, and with an overall system **20** substantially configured as shown, it is expected that approximately fifty to ninety percent (50-90%) of the total fluid volume or flow will exit the sample port **100** and approximately ten to fifty percent (10-50%) of the total fluid volume or flow will exit the non-sample drain **110**. Those skilled in the art will appreciate that all such flow distributions are merely illustrative of aspects of the present invention and are expressly non-limiting.

20

[0037] With continued reference to Figs. 1-4 illustrating an exemplary embodiment of the present invention, attractants **80** may be positioned within the sample area **60** substantially along the sample passage **62** for the purpose of drawing or attracting live organisms to the sample port area. Such attractants **80** may be a remote light source emitting a spectrum of light energy that live organisms are drawn to, shining through the sample passage **62** around the blocking chute **70** and through the sample passage inlet **66** and/or along the inlet **66**, such as spaced along the sample passage lips **64**, thereby somewhat simulating sunlight, or moonlight, or green “phytoplankton” through crevasses of a rock. For example, a wavelength of approximately 530 nm (green) appears to be effective as an attractant relative to representative organisms such as zooplankton. Simulated “plant life” could also be attractive, and also add fluid damping and act as additional flow control guides into the sample port area. Similarly,

30

- 13 -

repellants **90** may be positioned within the sample area **60** substantially adjacent or at least in the vicinity of the non-sample drain **110** for the purpose of repelling living organisms from the non-sample drain **110**. For example, the repellent(s) **90** could comprise a particular acoustic source that would simulate a predator, with the idea being to cause the microorganisms to “fear” and “flee” the non-sample drain area. Once more, those skilled in the art will appreciate that other such attractants and repellants may be employed in a variety of ways and locations within the sample acquisition system **20** without departing from its spirit and scope.

[0038] More generally, the disclosed sample acquisition system **20** or other equivalent structure facilitates improved performance through: (i) substantially real-time and on-line sample acquisition based on an isokinetic-type fluid flow sampling; (ii) efficient and effective separation of live organisms from dead or inorganic material within the sample; and (iii) removal of a significant amount of non-live material prior to sample evaluation. Further, such a sample acquisition system exhibits relatively minimal inertial excitation of the sample, minimal latency, and system bypass when crossing low turbidity waters, such as an open ocean with no river influence.

[0039] Turning now to Figs. 5-9, there are shown various perspective or sectioned views of an alternative sample acquisition system **20** according to aspects of the present invention. Once more, the system **20** generally comprises a sampling probe **30** in fluid communication with a separating pipe **40** that itself is in fluid communication with and transitions to a sample area **60** wherein the separation of live organisms from dead organisms or inorganic matter is facilitated as above-described. As will be appreciated particularly from the perspective views of Figs. 5 and 6, in the alternative exemplary embodiment, once exiting the flow pipe **P**, the separating pipe **40** twists through approximately a three hundred-fifteen degree (315°) helix, the twisting pipe causing inertial effects as the fluid flows therethrough, whereby the fluid flow is accelerated or has a relatively higher velocity along the outside of the curve, thus encouraging the relatively higher density dead or inorganic matter toward the outside of the curve, while the flow is relatively slower toward the inside of the curve. Again, geometric and material selections and/or optional surface treatments may further enhance the frictional and thus velocity effects to assist in encouraging the described separation. It will be appreciated by those

- 14 -

skilled in the art that while a particular shape and helix of the separating pipe **40** is shown and described the invention is not so limited; rather, a variety of other geometries of the separating pipe **40** are possible without departing from its spirit and scope. As previously indicated, though not shown, the sample port **100** would lead to a downstream microorganism analysis section (not shown) and the non-sample drain **110** would simply discharge to a tank (not shown) or otherwise be taken out of the system **20** or any related analysis section (not shown). The optional debris screen **36** and bubble collapsing screen **38** shown in Fig. 1 as being adjacent the sampling tip **34** are not shown in Figs. 5 and 7 for simplicity. An attractant **80** such as a light source may again be positioned within the sample port **100** downstream of or behind the sample passage **62** and blocking chute **70** and a repellent **90** such as an acoustic device may be positioned near the bottom of the sample area **60** in the vicinity of the non-sample drain **110**, as shown in Fig. 7. As best seen in the enlarged partial cross-sectional view of Fig. 8, the sample area **60** is again formed having a profile that substantially approximates an inverted triangle, thereby effectively speeding and funneling the outer flow toward, into, and through the discharge channel **50** and slowing the inner flow due to geometric and frictional effects and thereby allowing relatively lower density living organisms to make their way into the sample passage **62** and around the blocking chute **70** and into the sample port **100** for downstream processing. Particularly regarding the sample passage **62**, and with further reference to the further enlarged partial sectional schematic view of Fig. 9, which it will be appreciated is effectively a “slice” of the component as sectioned in Fig. 8 with the remaining features behind the “slice” removed for simplicity so as to more clearly see the features of the sample passage **62**, there is again shown a relatively narrower sample passage inlet **66** formed between opposite sample passage lips **64** and a concave downwardly- or inwardly-facing surface **72** of the blocking chute **80** cooperating to deflect and direct toward the lower non-sample drain **110** (Fig. 7) any dead or inorganic matter, with basically only living organisms navigating the sample passage **62** around the margins of the blocking chute **70** between it and the inside surface **68** of the passage **62** and then out through the sample port **100** as shown. It will once again be appreciated by those skilled in the art that while a particular configuration of the sample passage **62** and blocking chute **70** effectively suspended therein are shown and described, the invention is not so limited, but may take a number of other forms without departing from its spirit and scope.

- 15 -

[0040] Finally, referring now to the schematics of Figs. 10-13, which are somewhat analogous to those of Figs. 1-4, though here effectively corresponding to the alternative exemplary embodiment of Figs. 5-9, it can first be seen that the sampling probe **30** beyond the inlet or intake section tip **34** then bends substantially forty-five degrees (45°) so as to extend rearwardly in the flow and pass through the wall of the flow pipe **P** still at a substantially forty-five-degree angle as shown. It will be appreciated that such an angle of the sampling probe **30** may facilitate transition to the helical separating pipe **40** and introduce relatively less turbulence to the passing main fluid flow, or certainly would shift any such turbulence or disturbance to the representative or normalized velocity profile **V** further downstream of the probe inlet **34** and any related flow sensor (not shown). Those skilled in the art will once again appreciate that other geometrical configurations of the probe **30** are possible without departing from the spirit and scope of the invention. Next, regarding the separating pipe **40**, the channel **50** is again shown as following the twist so as to remain substantially at the outer part of the curve and thereby capture and direct downwardly through the system **20** the relatively higher density dead and inorganic material that preferably does not make its way into the analysis section by way of the sample passage **62** of the sample area **60** and the downstream sample port **100**. Once more, attractants **80** may be positioned in one or more locations adjacent or behind the sample blocking chute **70** to further encourage living organisms into and through the sample passage **62**, whereas repellants **90** may be positioned near the lower end of the sample area **60** to discourage living organisms from approaching the non-sample drain **110**. As can be seen in Fig. 10 particularly, in the alternative embodiment, there are no traps or particle returns and lines **52-56** as in the embodiment of Figs. 1-4, here the discharge flow simply passing at relatively higher velocity down through the channel **50** in the outer curve. Furthermore, as shown in the section view of Fig. 11 taken through a representative profile of the separating pipe **40**, distinct from the somewhat analogous section view of Fig. 2, the pipe **40** is here shown as having the inverted triangle or "V" opening toward the substantially opposite sample passage **62** and so pointing or having its apex toward the channel **50**, so as to effectively funnel the relatively higher density dead or inorganic matter in the sample flow down into the channel **50** and away from the sample passage **62** as previously described. In this way, and with further reference to the sectional view of Fig. 12, in the alternative embodiment, the pipe **40** and sample area **60** maintain a more constant, even if tapering, profile along the length of the device

- 16 -

maintaining the relatively narrower “V” portion of the profile directed at or funneling toward the channel **50** at the “outside” of the curve where the flows are relatively faster, with the more “dome-shaped” portion of the profile remaining toward the “inside” of the curve where the flows are relatively slower, such “dome-shaped” inside wall eventually transitioning and giving way to the opening **66** to the sample passage **62** through which the living organisms move about the suspended blocking chute **70**. It will be appreciated by those skilled in the art that a variety of configurations and arrangements of the components of the sample acquisition system **20** according to aspects of the present invention are possible without departing from its spirit and scope, such that the disclosed embodiments and particular shapes of the separating pipe **40** and sample area **60** are to be understood as merely illustrative.

[0041] To summarize, regarding the exemplary embodiments of the present invention as shown and described herein, it will be appreciated that a sample acquisition system is disclosed as configured for substantially real-time sampling from a fluid flow with an effective means for readily then separating dead or inorganic material from the sample before evaluation. Because the principles of the invention may be practiced in a number of configurations beyond those shown and described, it is to be understood that the invention is not in any way limited by the exemplary embodiments and is able to take numerous forms without departing from the spirit and scope of the invention. Furthermore, the various features of each of the above-described embodiments and components may be combined in any logical manner and are intended to be included within the scope of the present invention. It will also be appreciated by those skilled in the art that the present invention is not limited to the particular geometries and materials of construction disclosed, but may instead entail other functionally comparable structure, now known or later developed, without departing from the spirit and scope of the invention.

25

[0042] While aspects of the invention have been described with reference to at least one exemplary embodiment, it is to be clearly understood by those skilled in the art that the invention is not limited thereto. Rather, the scope of the invention is to be interpreted only in conjunction with the appended claims and it is made clear, here, that the inventor believes that the claimed subject matter is the invention.

30

- 17 -

CLAIMS

What is claimed is:

1. A system for acquiring a fluid sample from a flow pipe, comprising:
 - 5 a sampling probe placed within the flow pipe;
 - a separating pipe in fluid communication with the sampling probe, the separating pipe being substantially helically curved and having formed therein an inwardly-opening lengthwise channel along the outside curve thereof, the separating pipe terminating in a sample area; and
 - 10 a lengthwise inwardly-opening sample passage in fluid communication between at least a portion of the sample area and a sample port, the sample passage being formed substantially opposite the channel and being further formed with a substantially collinear blocking chute suspended therein, whereby inertial effects induced in the separating pipe cause relatively higher density inorganic and dead organic material to funnel into the channel and out a non-sample drain formed in the sample area substantially opposite the separating pipe while
 - 15 allowing live organisms to navigate the sample passage around the blocking chute and out the sample port.
2. The system of claim 1 wherein the blocking chute is formed having a substantially concave inwardly-facing surface, whereby inorganic and dead organic material is deflected off the
- 20 inwardly-facing surface and otherwise funneled therealong toward the non-sample drain in cooperation with the channel.
3. The system of claim 2 wherein:
 - 25 the sample passage is formed having an interior sample passage surface; and
 - the blocking chute is substantially spaced from the sample passage surface so as to form fluid flow pathways about the blocking chute.
4. The system of claim 2 wherein the sample passage is formed having opposite sample passage lips defining a sample passage inlet.

30

- 18 -

5. The system of claim 4 wherein the sample passage inlet is narrower than the width of the blocking chute.
6. The system of claim 1 wherein an attractant is positioned within the sample port substantially behind the blocking chute, whereby living organisms within the fluid sample are attracted toward the sample passage.
7. The system of claim 6 wherein the attractant is a light source.
8. The system of claim 7 wherein the light source is configured to emit light having a wavelength of approximately 530 nm (green).
9. The system of claim 1 wherein an attractant is positioned substantially adjacent the sample passage, whereby living organisms within the fluid sample are attracted toward the sample passage.
10. The system of claim 9 wherein:
the sample passage is formed having opposite sample passage lips defining a sample passage inlet; and
the attractant is positioned on one of the sample passage lips substantially adjacent the sample passage inlet.
11. The system of claim 10 wherein the attractant is a light source.
12. The system of claim 11 wherein the light source is configured to emit light having a wavelength of approximately 530 nm (green).
13. The system of claim 1 wherein:
the blocking chute is formed having an inwardly-facing surface; and
an attractant is positioned on the inwardly-facing surface, whereby living organisms within the fluid sample are attracted toward the sample passage.

- 19 -

14. The system of claim 13 wherein the attractant is a light source.
15. The system of claim 14 wherein the light source is configured to emit light having a wavelength of approximately 530 nm (green).
- 5 16. The system of claim 1 wherein a repellent is positioned within the sample area substantially adjacent to the non-sample drain, whereby living organisms are discouraged from entering the non-sample drain.
- 10 17. The system of claim 16 wherein the repellent is an acoustic source configured to simulate a predator.
18. The system of claim 1 wherein the sampling probe is an isokinetic probe formed having a proximal end substantially adjacent the flow pipe and an opposite distal end suspended
15 substantially centrally within the flow pipe, the distal end defining a sampling tip orifice.
19. The system of claim 18 wherein the sampling probe substantially at the proximal end forms a substantially forty-five degree (45°) angle to the flow pipe.
- 20 20. The system of claim 18 wherein a debris screen is positioned within the flow pipe upstream of the distal end of the sampling probe.
21. The system of claim 20 wherein a bubble collapsing screen is positioned within the flow pipe between the debris screen and the distal end of the sampling probe.
- 25 22. The system of claim 18 wherein the sampling tip orifice has an inside diameter of approximately four millimeters (4 mm) tapering gradually to a sampling probe inside diameter of approximately twenty millimeters (20 mm).
- 30 23. The system of claim 1 wherein the separating pipe twists through approximately a three hundred-fifteen degree (315°) helix.

- 20 -

24. A system for acquiring a fluid sample from a flow pipe, comprising:

an isokinetic sampling probe placed within the flow pipe, the sampling probe formed having a proximal end substantially adjacent the flow pipe and an opposite distal end suspended substantially centrally within the flow pipe, the distal end defining a sampling tip orifice;

5 a separating pipe in fluid communication with the sampling probe, the separating pipe being substantially helically curved and having formed therein an inwardly-opening lengthwise channel along the outside curve thereof, the separating pipe terminating in a sample area; and

a lengthwise inwardly-opening sample passage in fluid communication between at least a portion of the sample area and a sample port, the sample passage being formed substantially
10 opposite the channel, whereby inertial effects induced in the separating pipe cause relatively higher density inorganic and dead organic material to funnel into the channel and out a non-sample drain formed in the sample area substantially opposite the separating pipe while allowing live organisms to navigate the sample passage and out the sample port.

15 25. A system for acquiring a fluid sample from a flow pipe, comprising:

a sampling probe placed within the flow pipe;

a curved separating pipe in fluid communication with the sampling probe, the separating pipe terminating in a sample area; and

a lengthwise inwardly-opening sample passage in fluid communication between at least a
20 portion of the sample area and a sample port, the sample passage defining a sample passage inlet and being further formed with a substantially collinear blocking chute suspended therein, the blocking chute being formed having a substantially concave inwardly-facing surface, whereby inertial effects induced in the separating pipe cause relatively higher density inorganic and dead organic material to funnel into the channel and out a non-sample drain formed in the
25 sample area substantially opposite the separating pipe and further whereby inorganic and dead organic material is deflected off the inwardly-facing surface of the blocking chute and otherwise funneled therealong toward the non-sample drain while allowing live organisms to navigate the sample passage around the blocking chute and out the sample port.

30

- 21 -

26. A method of acquiring a fluid sample from a flow pipe, comprising the steps of:

positioning a sampling probe within the flow pipe so as to pull the fluid sample therein by way of a distal sampling tip orifice thereof;

5 subjecting the fluid sample to inertial effects within a curved separating pipe in fluid communication with the sampling probe; and

flowing relatively higher density inorganic and dead organic material within an inwardly-opening lengthwise channel formed along the separating pipe and within a sample area thereof and out a non-sample drain formed in the sample area substantially opposite the separating pipe.

10 27. The method of claim 26 further comprising the step of passing live organisms through a sample passage in fluid communication between at least a portion of the sample area and a sample port.

15 28. The method of claim 27 wherein the step of passing live organisms through the sample passage further comprises passing the organisms around a substantially collinear blocking chute suspended therein.

20 29. The method of claim 28 further comprising the step of deflecting inorganic and dead organic material off of an inwardly-facing surface of the blocking chute and otherwise funneling the inorganic and dead organic material therealong toward the non-sample drain in cooperation with the channel.

25 30. The method of claim 26 comprising the further step of reducing bubbles within the fluid sample by positioning a bubble collapsing screen within the flow pipe upstream of the distal sampling tip orifice.

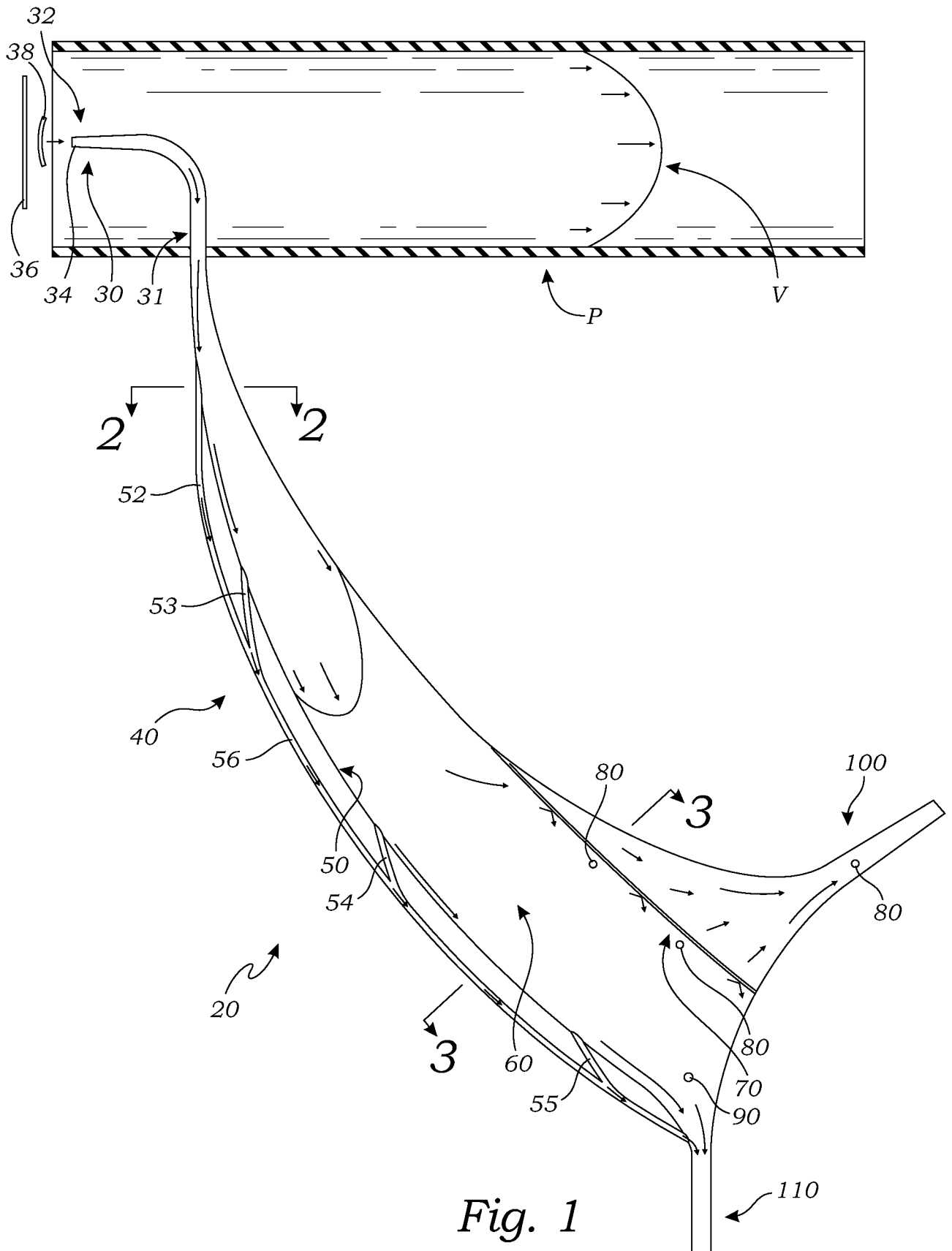

Fig. 1

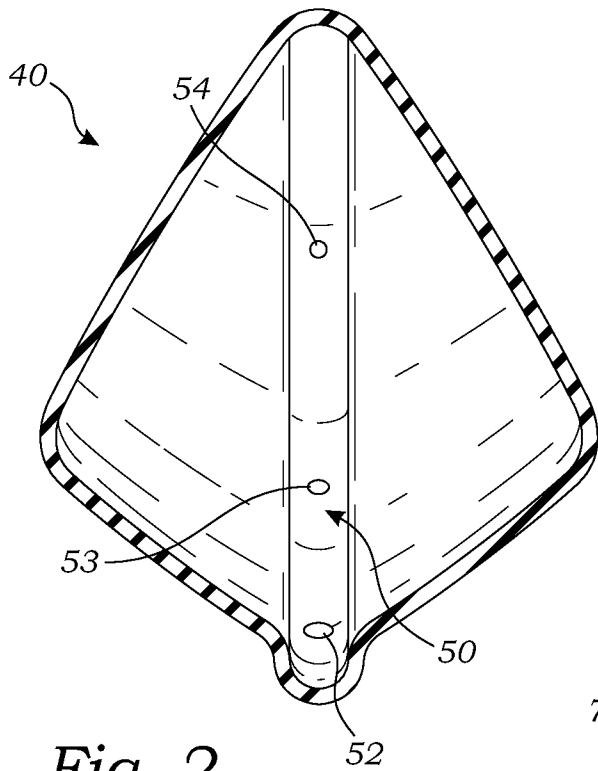

Fig. 2

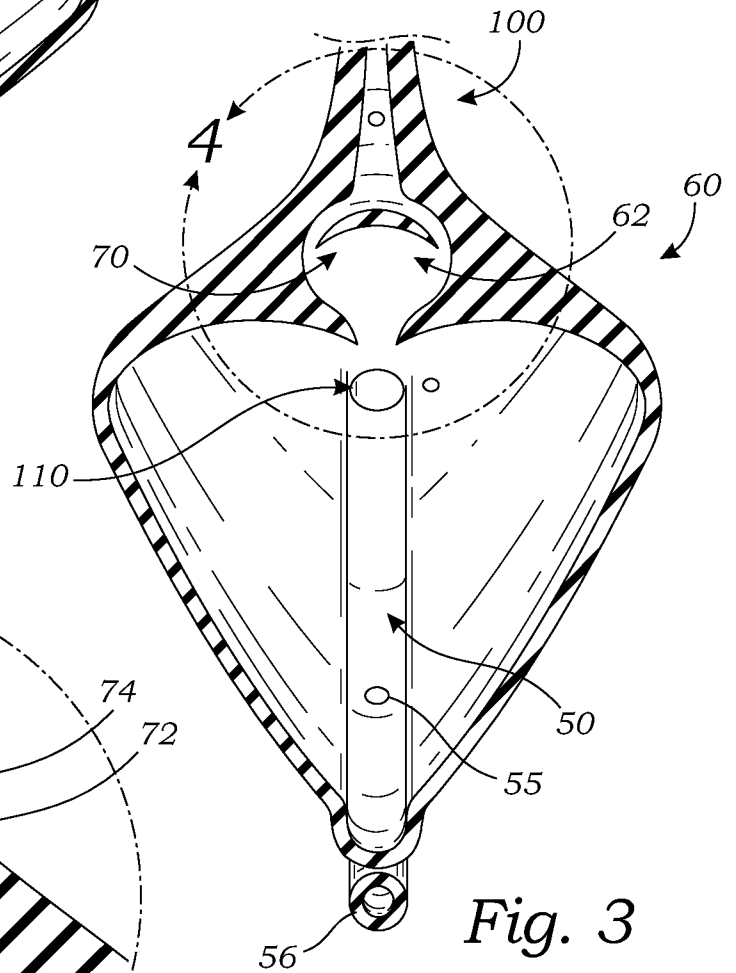

Fig. 3

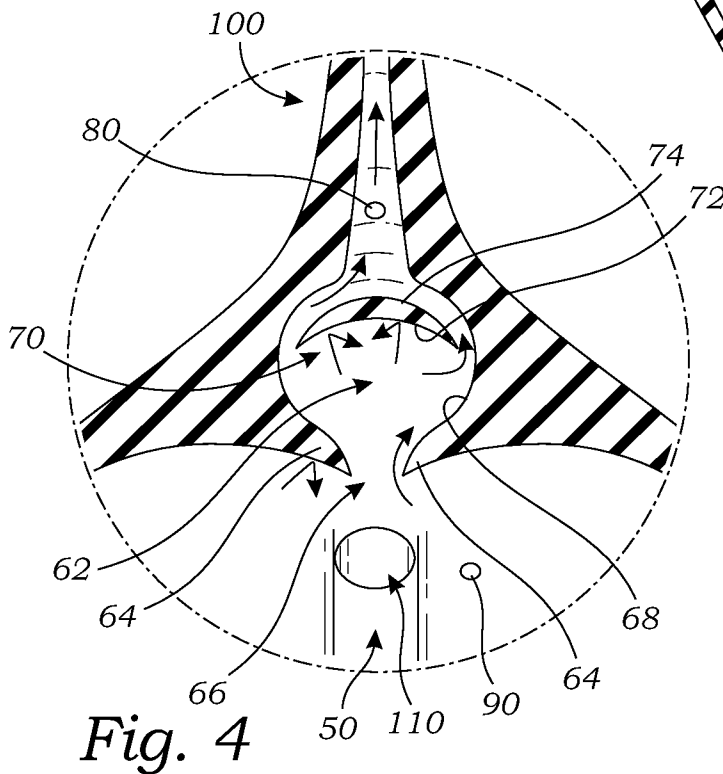

Fig. 4

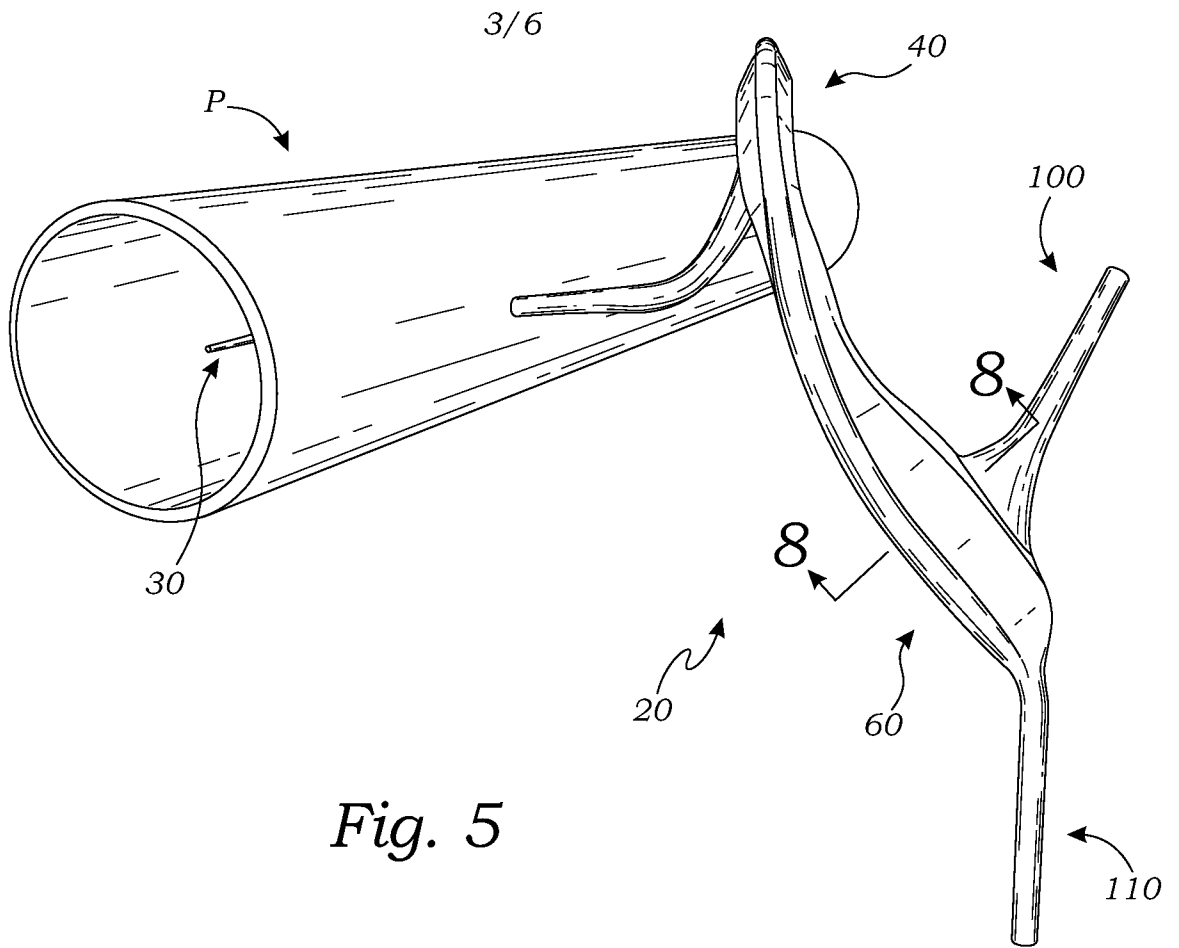

Fig. 5

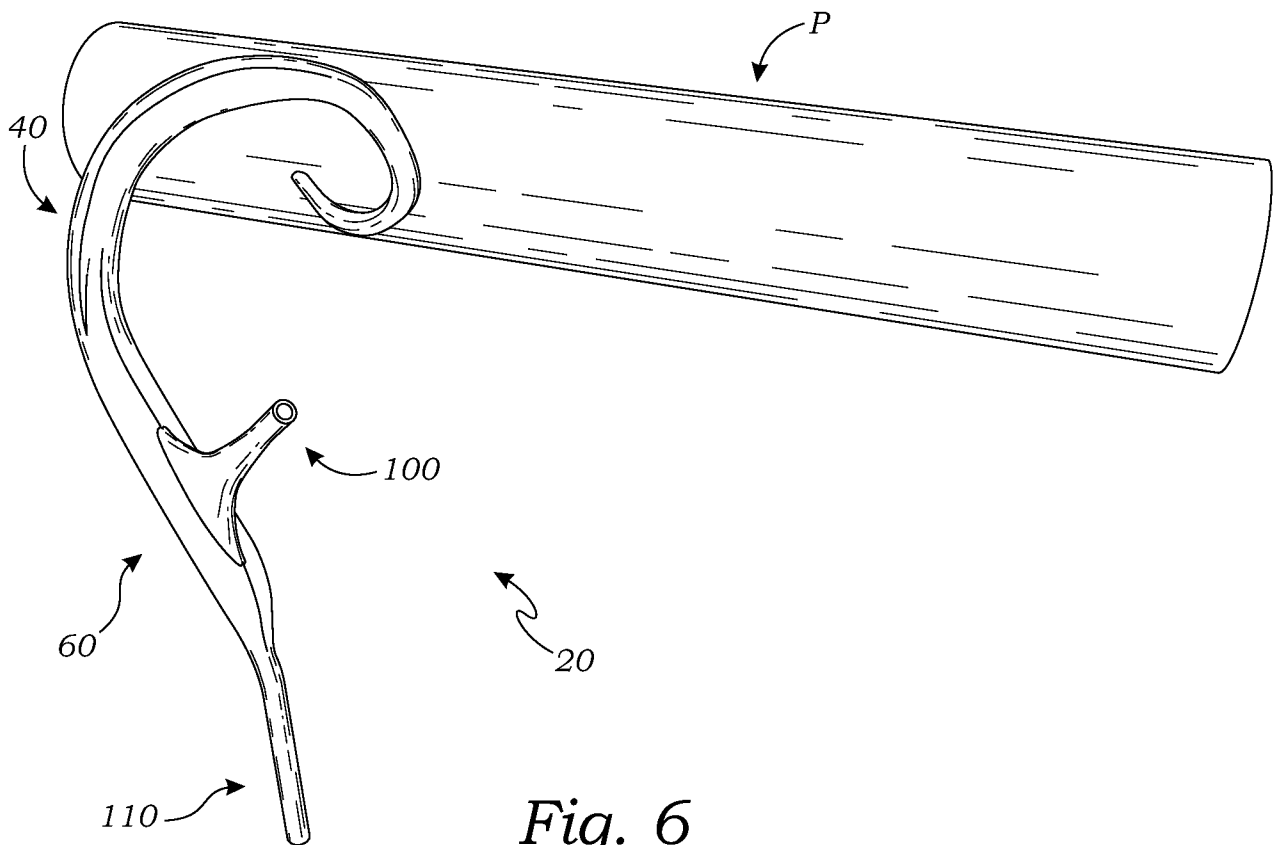

Fig. 6

5/6

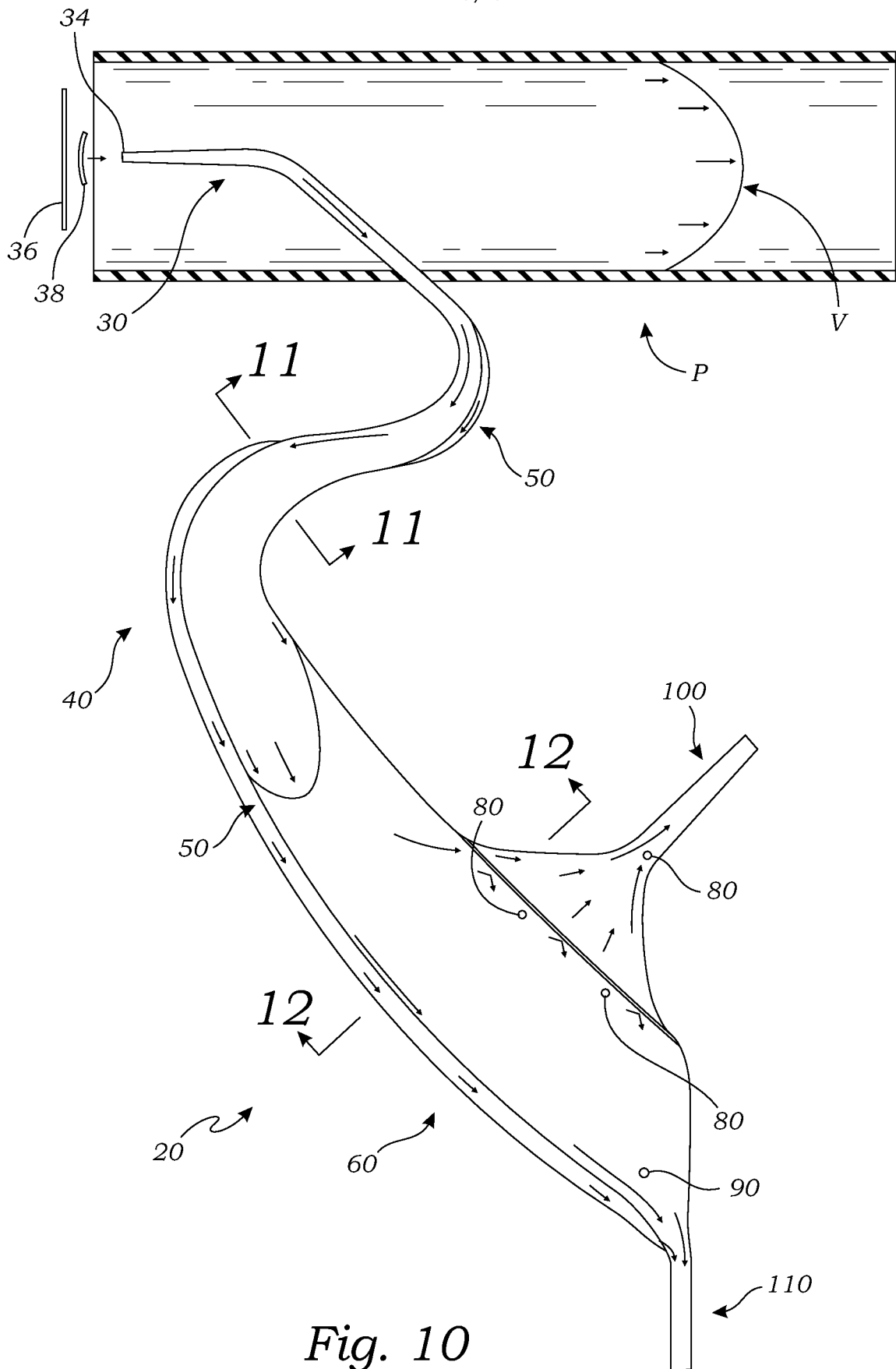

Fig. 10

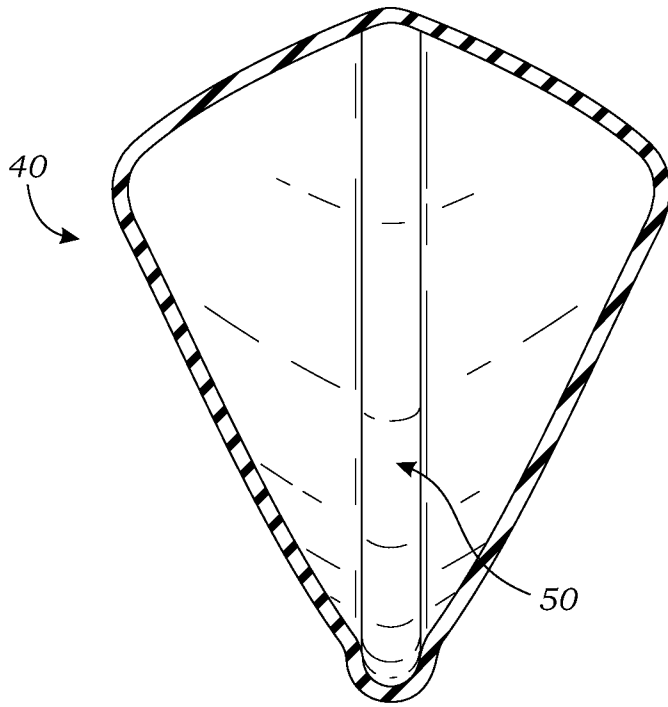

Fig. 11

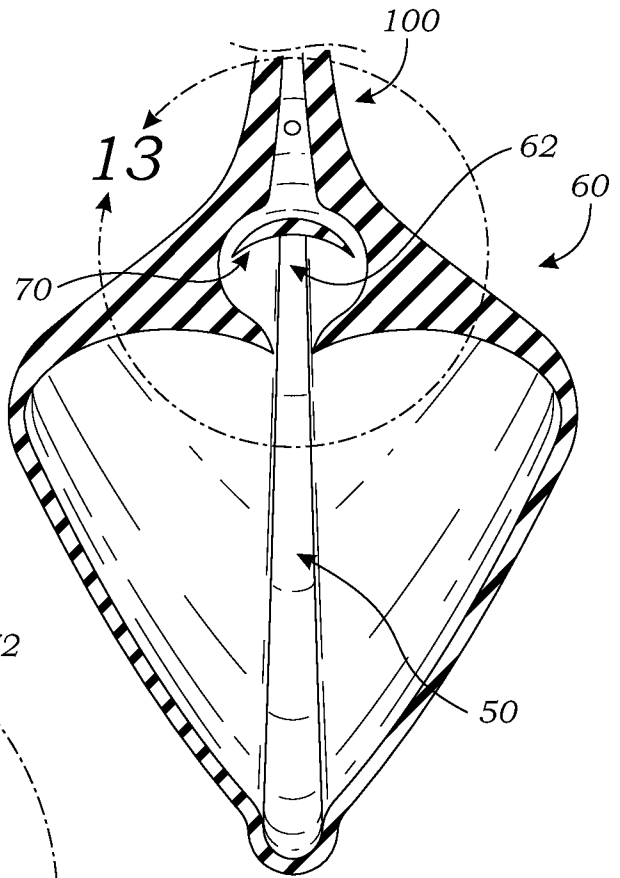

Fig. 12

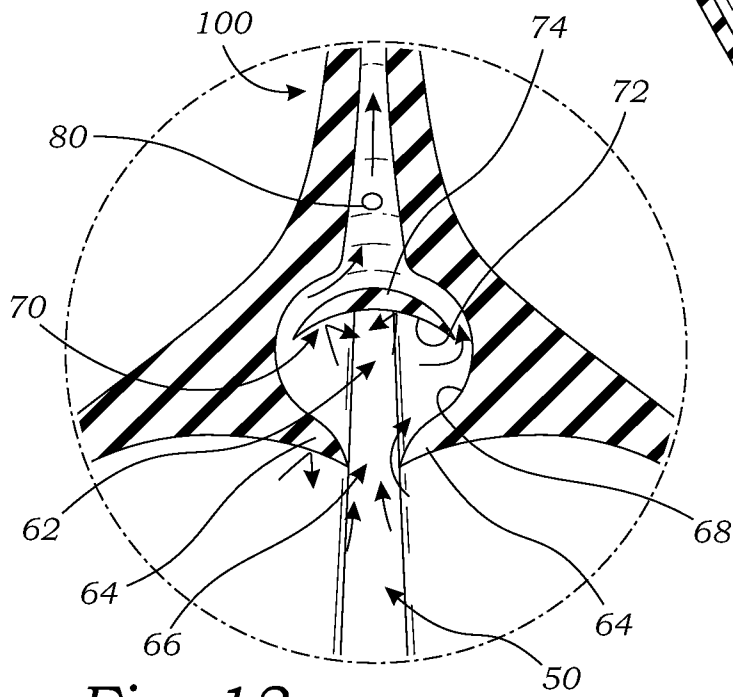

Fig. 13

A. CLASSIFICATION OF SUBJECT MATTER

IPC(8) - G01N 15/06 (2014.01)

USPC - 73/28.04

According to International Patent Classification (IPC) or to both national classification and IPC

B. FIELDS SEARCHED

Minimum documentation searched (classification system followed by classification symbols)

IPC(8) G01N 15/06 (2014.01)

USPC - 73/28.04

Documentation searched other than minimum documentation to the extent that such documents are included in the fields searched

IPC(8) - G01N 1/00 (2014.01)

USPC - 73/28.01, 863.51-863.55, 863.41, 863.58, 863.82, 863.85, 864.63-864.67, 863.81; 209/138-143

Electronic data base consulted during the international search (name of data base and, where practicable, search terms used)

Patbase Minesoft, FreePatentsOnline, Google Scholar: fluid, liquid, water, flow*, move*, pipe, conduit, hose, tube, sample*, probe, separate*, helical*, circular, spiral*, orbital, round, chute, channel, open*, orifice, port, dead, decese*, expire*, extenict, inorganic, organism*, live* funnel, isokinetic

C. DOCUMENTS CONSIDERED TO BE RELEVANT

Category*	Citation of document, with indication, where appropriate, of the relevant passages	Relevant to claim No.
A	US 3,555,910 A (SPENCE et al.) 19 January 1971 (19.01.1971) entire document	1-30
A	US 7,111,521 B1 (ANDREWS, JR.) 26 September 2006 (26.09.2006) entire document	1-30
A	US 2011/0271739 A1 (GOOHS et al.) 10 November 2011 (10.11.2011) entire document	1-30
A	US 7,717,000 B2 (XIE et al.) 18 May 2010 (18.05.2010) entire document	1-30
A	US 5,811,696 A (JOBSON) 22 September 1998 (22.09.1988) entire document	1-30

Further documents are listed in the continuation of Box C.

* Special categories of cited documents:	"T" later document published after the international filing date or priority date and not in conflict with the application but cited to understand the principle or theory underlying the invention
"A" document defining the general state of the art which is not considered to be of particular relevance	"X" document of particular relevance; the claimed invention cannot be considered novel or cannot be considered to involve an inventive step when the document is taken alone
"E" earlier application or patent but published on or after the international filing date	"Y" document of particular relevance; the claimed invention cannot be considered to involve an inventive step when the document is combined with one or more other such documents, such combination being obvious to a person skilled in the art
"L" document which may throw doubts on priority claim(s) or which is cited to establish the publication date of another citation or other special reason (as specified)	"&" document member of the same patent family
"O" document referring to an oral disclosure, use, exhibition or other means	
"P" document published prior to the international filing date but later than the priority date claimed	

Date of the actual completion of the international search 21 July 2014 (21.07.2014)	Date of mailing of the international search report 08 AUG 2014
--	--

Name and mailing address of the ISA/US Mail Stop PCT, Attn: ISA/US, Commissioner for Patents P.O. Box 1450, Alexandria, Virginia 22313-1450 Facsimile No. 571-273-3201	Authorized officer: Lee W. Young PCT Helpdesk: 571-272-4300 PCT OSP: 571-272-7774
---	--