

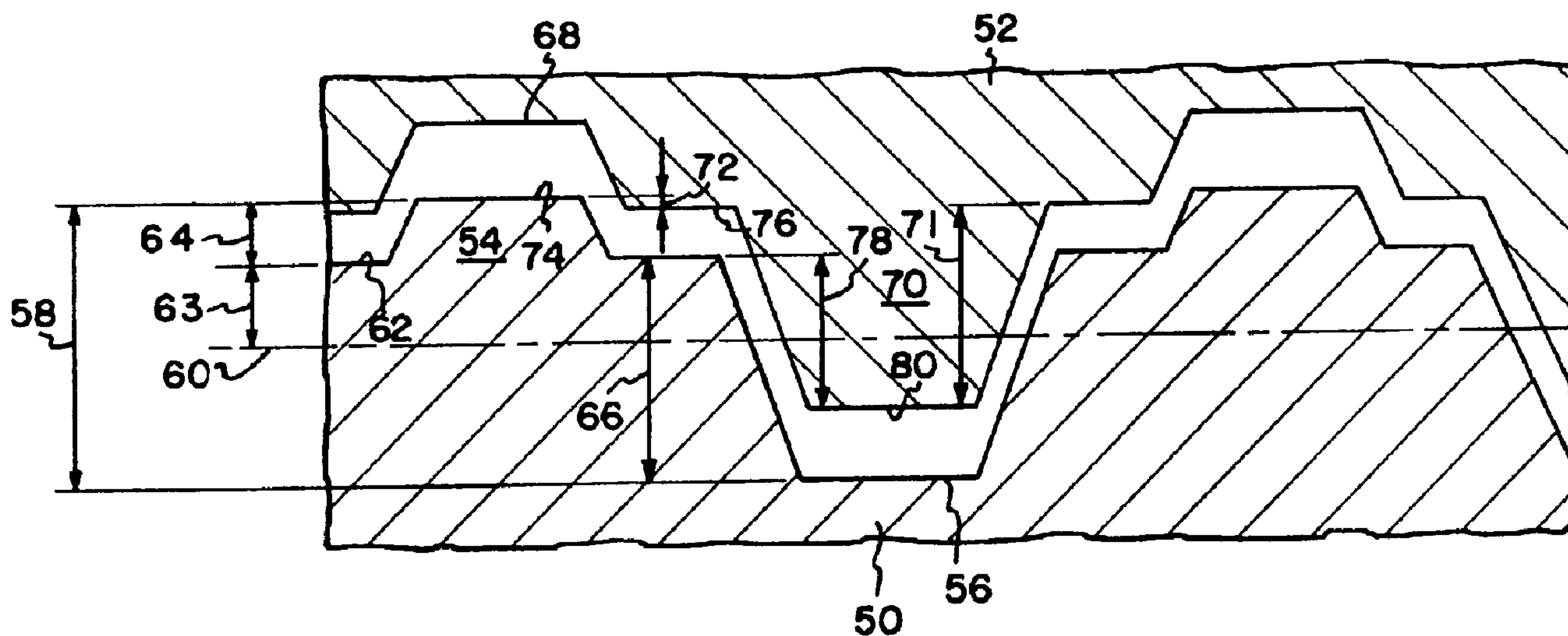

(22) Date de dépôt/Filing Date: 1998/12/11
 (41) Mise à la disp. pub./Open to Public Insp.: 1999/06/30
 (45) Date de délivrance/Issue Date: 2008/07/29
 (30) Priorité/Priority: 1997/12/30 (US09/000,535)

(51) Cl.Int./Int.Cl. *B31F 1/07* (2006.01),
D21F 11/00 (2006.01)
 (72) Inventeur/Inventor:
BURGESS, WILLIAM H., US
 (73) Propriétaire/Owner:
KIMBERLY-CLARK WORLDWIDE, INC., US
 (74) Agent: BORDEN LADNER GERVAIS LLP

(54) Titre : METHODE ET APPAREIL POUR LE GAUFRAGE DE MATERIAU EN BANDE AU MOYEN D'UNE SURFACE DE GAUFRAGE A EPAULEMENT DECENTRE
 (54) Title: METHOD AND APPARATUS FOR EMBOSsing WEB MATERIAL USING AN EMBOSsing SURFACE WITH OFF-CENTERED SHOULDERS



(57) Abrégé/Abstract:

Webs can be embossed using matched embossing elements with shoulders located off-centered. Such a configuration increases the bulk of the web and maintains the web's strength. The shoulder of one roll is located above or below the embossing surface mid-plane. The shoulder of the second roll substantially matches the off-centered elements of the first roll.

Abstract

5 Webs can be embossed using matched embossing elements with shoulders located off-centered. Such a configuration increases the bulk of the web and maintains the web's strength. The shoulder of one roll is located above or below the embossing surface mid-plane. The shoulder of the second roll substantially matches the off-centered elements of the first roll.

10

**METHOD AND APPARATUS FOR EMBOSSING WEB MATERIAL USING AN
EMBOSsing SURFACE WITH OFF-CENTERED SHOULDERS**

Technical Field

5 This invention generally relates to an apparatus
and method of embossing a cellulosic web of material,
and more particularly to embossing a cellulosic web of
material using embossing elements with shoulders located
away from the embossing surface mid-plane.

10

Background

 Paper products generally in the form of a
cellulosic web, such as paper towels, wipers, and facial
tissue are manufactured widely in the paper making
15 industry. Each product has unique product
characteristics requiring the appropriate blend of
product attributes to ensure that a product can be used
in its intended use locus. These attributes include
tensile strength, water absorbency, softness, and bulk.

20

 To achieve these product attributes, different
manufacturing processes are utilized. One common
process is embossing. Embossing increases the bulk of
the product and enhances absorbency. In addition,
embossing improves the product's aesthetic appeal.
25 Generally, a stiffer web is easier to emboss because the
more resilient the web is, the more difficult it is to
retain the embossing pattern. However, increasing web
stiffness has an adverse impact on web softness. Also,
traditional embossing methods reduce the strength of the
30 web. Therefore conventional embossing techniques tend
to reduce the strength of the web in an effort to attain
suitable bulk.

 Conventional embossing techniques include a matched
pair of embossing rolls, arranged to move relative to
35 each other to form a roll nip. Generally the web is
embossed by passing it through matching male and female

embossing elements. The protrusion of the male element on one roll matches within the depression of the female element on the opposite roll, thereby deflecting the web and imparting an embossment at that point. The amount of penetration by the male element into the female element affects the extent of embossing. Traditional embossing techniques have been concerned with varying the amount of penetration. Embossing patterns have been altered in order to increase bulk yet maintain web strength. Much of these conventional embossing improvements have centered on the configuration of the embossing pattern. For example, the embossing pattern has been altered to produce a higher bulk and softer embossed sheet. See U.S. Pat. No. 5,562,805 to Kamps et al., where fine-scale intermeshed embossing elements of two rolls emboss the tissue thereby increasing tissue surface fuzziness which can improve softness.

Recent attempts have concentrated on the distinct geometry of the male and female embossing elements. For example, U.S. Patent No. 5,356,364 to Veith et al. utilizes unmatched male and female embossing elements. The side wall slope of the matched elements are different, causing the web to be pinched at distinct points within each embossing element.

Other recent improvements in embossing methods involve adding a ridge or shoulder to the embossing elements. See U.S. Pat. No. 4,543,142 to Kuepper et al, where a shoulder is placed at the elements mid-plane. See also, U.S. Pat. No. 4,921,034 to Burgess et al, where a paper product has a plurality of bosses alternating about a centered shoulder.

Other attempts to improve the embossing pattern have involved changing the roll material from traditional steel to a softer material. See U.S. Pat. No. 4,211,743 to Nauta et al., where the embossing rolls have a resilient surface of varying hardness. The

resilient surfaces temporarily deform within the nip thereby ensuring that the web material is fully contacted by the embossing pattern.

Traditional embossing methods of cellulosic webs
5 continue to have many shortcomings. There is a need for an embossing method that increases the bulk of the web while maintaining adequate web strength.

Summary

10 The present invention provides a method and apparatus for embossing a cellulosic web by passing the web between first and second rotatable rolls. The rotatable rolls have an embossing pattern with
15 alternating male and female elements. Each roll has an embossing pattern mid-plane located equidistant the male element top and female element bottom. The first roll has shoulders located between the embossing pattern mid-plane and the male element top, and the second roll has its corresponding shoulders located between the
20 embossing pattern mid-plane and the female element bottom. The corresponding male and female embossing elements intermesh and deflect the web perpendicular to its plane causing alternating protrusions and depressions in the web.

25 In one aspect, the invention provides a method for embossing an absorbent paper web comprising the steps of:

- (a) passing the web between first and second rotatable rolls, said rotatable rolls having a
30 cylindrical outer surface, said surfaces having an embossing pattern, said first and second roll embossing patterns defined by a plurality of raised male elements and a plurality of recessed female elements, said male elements having a top

- female elements, said male elements having a top and a base, said female elements having a bottom and a base, each roll having an embossing pattern mid-plane located equidistant male top and female bottom, each roll having an embossing shoulder located connecting adjacent male and female bases, at least one of said first roll embossing shoulders located between first roll embossing pattern mid-plane and male top, at least one of said second roll embossing shoulders located between second roll embossing pattern mid-plane and female bottom, said male element having a height defined by the distance from the embossing shoulder to the top, said female element having a depth defined by the distance from the embossing shoulder to the bottom, the male height being less than the female depth, and the ratio of the male height to the female depth being from about 0.0625 to about 0.4375;
- (b) rotating the rolls such that male and female embossing elements intermesh and deflect the web perpendicular to its plane causing alternating protrusions and depressions in the web;
 - (c) driving the surface of the rotatable rolls at a speed substantially equal to the speed of the web; and
 - (d) removing the web from the rotatable rolls.

In another aspect, the invention provides a method for embossing an absorbent paper web comprising the steps of:

- (a) passing the web between first and second rotatable rolls, said rolls having a cylindrical

- outer surface, said surfaces having an embossing pattern, said first and second roll embossing patterns defined by a plurality of raised male elements and a plurality of recessed female elements, said male elements having a top and a base, said female elements having a bottom and a base, each roll having an embossing pattern mid-plane located equidistant male top and female bottom, each roll having an embossing shoulder located connecting adjacent male and female bases, at least one of said first roll embossing shoulders is located at said first roll embossing pattern mid-plane and at least one of said first roll embossing shoulders is located between said first roll embossing pattern mid-plane and said male top;
- (b) rotating the rolls such that male and female embossing elements intermesh and deflect the web perpendicular to its plane causing protrusions and depressions in the web;
 - (c) driving the surface of the rolls at a speed substantially equal to the speed of the web; and
 - (d) removing the web from the rolls.

In a further aspect, the invention provides a method for embossing an absorbent paper web comprising the steps of:

- (a) passing the web between the first and second rotatable rolls, said rolls having a cylindrical outer surface, said surfaces having an embossing pattern, said first and second roll embossing patterns defined by a plurality of raised male elements and a plurality of recessed female

- elements, said male elements having a top and a base, said female elements having a bottom and a base, each roll having an embossing pattern mid-plane located equidistant male top and female bottom, each roll having an embossing shoulder located connecting adjacent male and female bases, at least one of said first roll embossing shoulder is located between said first roll embossing pattern mid-plane and said female bottom, and at least one of said first roll embossing shoulders is located between said first roll embossing pattern mid-plane and said male top;
- (b) rotating the rolls such that male and female embossing elements intermesh and deflect the web perpendicular to its plane causing protrusions and depressions in the web;
 - (c) driving the surface of the rolls at a speed substantially equal to the speed of the web;
 - and
 - (d) removing the web from the rolls.

Description of the Drawings

Figure 1 is a fragmentary schematic front view of prior art embossing using an embossing roll with male elements.

5 Figure 2 is a fragmentary schematic front view of prior art embossing rolls with male and female embossing elements alternating about a centered shoulder.

Figure 3 is a fragmentary schematic front view of the embossing method of the present invention.

10 Figure 4 is an alternative embodiment of the embossing method of the present invention showing an embossing surface with shoulders alternating between off-centered and centered.

15 Figure 5 is an alternative embodiment of the embossing method of the present invention showing an embossing surface with shoulders alternating above and below the surface mid-plane.

Detailed Description

20 The invention resides in an embossed cellulosic web product, including paper and tissue, that can be used to form a facial tissue or towel structure. The web can be layered or nonlayered, creped or uncreped, wet pressed or throughdried, preheated, premoistened, and can be
25 single-ply or two-ply or multiply ply.

A preferred embodiment of the invention will be described in detail with reference to the drawings, wherein like reference numerals represent like parts and assemblies throughout the several views. Reference to
30 the preferred embodiment does not limit the scope of the invention, which is limited only by the scope of the claims attached hereto.

In general, the present invention relates to an apparatus and method of embossing a cellulosic web of
35 material, and more particularly to embossing a web of cellulosic material using embossing surfaces with

shoulders located away from the embossing surface mid-plane. Depending on the embodiment that is used, the invention allows for an embossed web with increased bulk that maintains web strength.

5 The present invention has many advantages. One advantage is that it increases bulk in an embossed web, by utilizing a unique embossing structure. The increased bulk yields more roll building such that less web is required to produce a roll of constant diameter.
10 The present invention allows for this increase in bulk yet maintains adequate levels of web strength.

Figure 1 shows a prior art embossing process in which a web is embossed between matched embossing elements. Generally, male embossing elements are
15 protrusions and female embossing elements are depressions. First embossing roll 10 has male embossing elements 12 extending from the first roll surface 14. Second embossing roll 16 has female embossing elements 18 recessed from the second roll surface 20. The male
20 embossing elements 12 engage with the female embossing elements 18. The top 22 of the male element partially penetrates the female depression. The top 22 of the male element may or may not come into contact with the bottom 24 of the female element. The degree of roll
25 engagement is indicated by the distance 26, which is the distance that the male element penetrates the female depression. The distance 26 is known as the embossing level. The embossing level is used to control the amount and quality of the embossments. For example, a
30 higher embossing level leads to more penetration and therefore to larger embossments.

Figure 2 shows a prior art embossing method in which both rolls contain male and female embossing elements. The first roll 28 has male embossing elements
35 30 and female embossing elements 32. The second roll 34 has female embossing elements 36 and male embossing

elements 38. The depth of the first roll's embossing surface is indicated by reference numeral 40. The mid-plane of the embossing roll surface is indicated by line 42. The embossing roll's shoulder 44 coincides with the embossing surface's mid-plane. This configuration is conventional. In such a configuration, the height 46 of the male embossing element is substantially equal to the depth 48 of the female element. Conventional embossing methods allowed for minor variations in the depth of the female element to account for dust or other particulate matter that may settle in the grooves of the female elements.

Figure 3 shows the method of embossing according to the principles of the present invention. A first embossing roll 50 engages a second embossing roll 52 to emboss the cellulosic web. The first roll 50 has male embossing elements 54 and female embossing elements 56. The depth of the embossing surface is indicated by reference numeral 58 and the mid-plane of the embossing surface is indicated by the line 60. The shoulder 62 of the first embossing roll 50 does not coincide with the mid-plane 60. The shoulder 62 is located above the mid-plane 60 by the distance 63. The shoulder 62 is also known as the shelf or source plane. The height of the male element is indicated by reference numeral 64 and the depth of the female element is indicated by reference numeral 66. The female depth 66 is greater than the male height 64. The ratio of male height 64 to female depth 66 is between 0.0625 and 0.4375 preferably 0.25.

The second roll 52 has a corresponding set of female elements 68 and male elements 70. The first roll's male and female elements 54, 56 substantially match the second roll's female and male elements 68, 70. For example, the depth 66 of the first roll's female element 56 is substantially equal to the height 71 of

the second roll's male element 70. The male embossing elements are designed to partially engage the corresponding female embossing element. The first roll's embossing level is indicated by reference numeral 5 72 which is the distance from the top 74 of the first roll's male element to the shoulder 76 of the second roll 52. The second roll's embossing level is indicated by reference numeral 78 which is the distance between the first roll's shoulder 62 and the top 80 of the 10 second roll's male element 70. In the preferred embodiment, as shown in Figure 3, the shoulder 62 of all male embossing elements is located the same distance 63 from the mid-plane 60. As a result, the embossing level and all resulting embossments will be of the relatively 15 similar dimensions.

In designing the size of the male and female embossing elements, it is preferable that the length and width of the elements is equal to or greater than the distance between surrounding adjacent elements. If the 20 element size is maintained a constant, the density of the elements (the number of elements per square centimeter) can be increased by decreasing the space between the elements. Alternatively, if the density of the element is maintained constant, the element size can 25 be increased by decreasing the space between the elements.

The vertical profile of the male and female embossments can take on multiple configurations. In the preferred embodiment, the male and female embossments 30 are oblong in shape, when viewed from the top. The preferred embossments are shown in U.S. Patent 4,921,034. It will be appreciated that the precise spacing and shape of the embossments can vary depending upon the process requirements. 35 Alternatively, the embossments may shape

when viewed from the top including but not limited to hexagonal, oval, circular, and rectangular.

Figure 4 shows an alternative configuration of the embossing method of the present invention showing the shoulder alternating between an off-centered and centered position. A first embossing roll 150 engages a second embossing roll 152 to emboss the cellulosic web. The first roll 150 has two sets of male embossing elements 154, 155 and two sets of female embossing elements 156, 157. The depth of the embossing surface is indicated by reference numeral 158 and the mid-plane of the embossing surface is indicated by line 160. Roll 150 has two sets of shoulders 162, 163. The first shoulder 162 is associated with the first set of male embossing elements 154. The first shoulder 162 coincides with the mid-plane 160. The height of the first male embossing element is indicated by reference numeral 164. The second shoulder 163 is associated with the second set of male embossing elements 155. The second shoulder 163 is located above the mid-plane 160 by a distance 165. The second roll 152 has two sets of female embossing elements 168, 169 and two sets of male embossing elements 170, 171. The first roll embossing element sets substantially match the corresponding second roll embossing element sets.

Such a configuration would produce a cellulosic web with embossments on each side. The resulting web would have alternating embossments. The embossment in the web imparted by element 154 would be higher than the web embossment imparted by element 155. This means that each consecutive embossment would be different. The resulting web would have more bulk than a web produced by the rolls described in Figure 2. In addition, such a configuration would enhance the surface texture of the resulting product. It is believed that such a product

would have superior aesthetic attributes as well as a surface with a variety of embossments.

It will also be appreciated that the distance 165 from the shoulder to the mid-plane can be varied. The ratio of the shoulder distance 165 to the male element height 164 distance is 0.125 to 0.875, preferably 0.5.

It will also be appreciated that the location of elements with off-centered shoulders can be varied. Different regions of the embossing surface can have off-centered shoulders. For example, the elements located near the center of the embossing rolls have matching elements with centered shoulders and the elements located near the edges of the embossing rolls have matching elements with off-centered shoulders. It is believed that webs produced from such a process would have greater bulk near the edges of the resulting web. Different combinations of off-centered shoulders can be used. These combinations lead to different patterns and different web bulk. There are many different suitable combinations of elements that are within the scope of the present invention. In addition, it is believed that such a web maintains adequate levels of strength.

Figure 5 shows yet another alternative configuration of the embossing method of the present invention. This method also utilizes off-centered shoulders. The shoulders are located both above and below the mid-plane. A first embossing roll 250 engages a second embossing roll 252 to emboss the cellulosic web. The first roll 250 has two sets of male embossing elements 254, 255 and two sets of female embossing elements 256, 257. The depth of the embossing surface is indicated by reference numeral 258 and the mid-plane of the embossing surface is indicated by line 260. Roll 250 has two sets of shoulder 262, 263. The first shoulder 262 is associated with the first set of male embossing elements 254. The first shoulder 262 is

located a distance 265 above the mid-plane 260. The male element height is indicated by reference numeral 264. The second shoulder 263 is associated with the second set of male embossing elements 255. The second
5 shoulder 263 is located below the mid-plane 260 by a distance 267. The second roll 252 has two sets of female embossing elements 268, 269 and two sets of male elements 270, 271. The first roll embossing element sets substantially match the corresponding second roll
10 embossing element sets.

This configuration would produce a product with more bulk than a product produced by the rolls in Figure 2. In addition, the products top and bottom surfaces would be substantially symmetrical. The top surface of
15 the resulting web would have similarly sized and shaped embossments as the bottom surface.

In the preferred embodiment the embossing elements are matched steel. However, one or both of the rolls may be covered with a deformable surface, such as rubber
20 or polyurethane. It is believed that deformable embossing elements yield slightly to the web and are less likely to damage the strength of the web during embossing. It is within the scope of this invention for the embossing elements to be steel or a combinations of
25 steel and rubber or other deformable materials. For example, the male elements can be steel and the female elements can be a deformable material, or vice versa. There are many different suitable combinations of materials that are within the scope of the present
30 invention. Deformable materials are more forgiving than steel and are less likely to cut the web as the top of the male embossing element penetrates the female element. The embossing rolls of the present invention can be manufactured using a laser engraving process.

35 In operation, as shown in Figure 3, a web is passed between the first embossing roll 50 and second embossing

roll 52. The corresponding male and female elements engage. The web, the first roll embossing surface or shoulder 62, and the second roll embossing surface or shoulder 76 move at substantially the same speed. As
5 the male and female elements are engaged, the male element penetrates the female element thereby extending the web to create a permanent deformation or embossment. This embossment creates a corresponding bulk increase. The presence of the off-centered shoulder 62 creates a
10 structure that allows for differentiation in the penetration of the male element. The embossments produced by this structure have more out of plane extension than a structure with the embossing surface located at the embossing surface mid-plane. As a
15 result, the overall bulk of the product is increased.

Sheet specific bulk is expressed as cubic centimeters per gram. The invention resides in cellulosic webs having a sheet specific bulk of about 6 cubic centimeters per gram or greater, more preferably
20 about 10 to 45 cubic centimeters per gram or greater.

Sheet bulk is derived from caliper. Caliper is measured substantially in accordance with TAPPI Standard T411-68 except for the loading on the pressure foot, which is 95 grams per square inch. The method utilizes
25 a TMI Bench Micrometer, Model 549MSP having a 2 inch diameter anvil, and comprises placing a single sheet of tissue on the anvil such that all points on the peripheries of the contact surfaces are at least a 0.25 inch in from the edges of the sample. The instrument
30 motor is started and two measurements are taken within 6 inches of each other in the cross-machine direction of the sample. A reading is taken near the end of the dwell time on each test and is read to the nearest scale division. The average of the two readings is the sheet
35 caliper of the web. The invention resides in cellulosic

webs having a sheet caliper of about .38 mm or greater, more preferably about .64 to .90 mm.

5 The embossing level is set according to the web material and the desired characteristics of the final web including strength and stack size density. The embossing level can be from about .1 to about 1.5 mm, more specifically from about .5 to about 1 mm.

10 The dimensions for the embossing elements provided herein are only for purposes of example and do not limit the scope of the claimed invention.

15 We believe that the use of the method of the present invention in embossing cellulosic sheets provides a substantial improvement in the bulk of the embossed sheet. The increase bulk is attained without comprising web strength.

20 Although the description of the preferred embodiment and method have been quite specific, modifications of the process of the invention could be made without deviating from the spirit of the present invention. Accordingly, the scope of the present invention is dictated by the appended claims, rather than by the description of the preferred embodiment and method.

CLAIMS:

1. A method for embossing an absorbent paper web comprising the steps of:

(a) passing the web between first and second rotatable rolls, said rotatable rolls having a cylindrical outer surface, said surfaces having an embossing pattern, said first and second roll embossing patterns defined by a plurality of raised male elements and a plurality of recessed female elements, said male elements having a top and a base, said female elements having a bottom and a base, each roll having an embossing pattern mid-plane located equidistant male top and female bottom, each roll having an embossing shoulder located connecting adjacent male and female bases, at least one of said first roll embossing shoulders located between first roll embossing pattern mid-plane and male top, at least one of said second roll embossing shoulders located between second roll embossing pattern mid-plane and female bottom, said male element having a height defined by the distance from the embossing shoulder to the top, said female element having a depth defined by the distance from the embossing shoulder to the bottom, the male height being less than the female depth, and the ratio of the male height to the female depth being from about 0.0625 to about 0.4375;

(b) rotating the rolls such that male and female embossing elements intermesh and deflect the web perpendicular to its plane causing alternating protrusions and depressions in the web;

(c) driving the surface of the rotatable rolls at a speed substantially equal to the speed of the web; and

(d) removing the web from the rotatable rolls.

2. The method of claim 1, wherein said ratio is about 0.25.
3. The method of claim 1 or 2, wherein the top of the first roll male element penetrates past the second roll embossing shoulder from about 0.1 to about 1.5 mm.
4. The method of claim 1 or 2, wherein the top of the first roll male element penetrates past the second roll embossing shoulder from about 0.5 to about 1.0 mm.
5. The method of any one of claims 1 to 4, wherein the embossing elements are matched steel.
6. The method of any one of claims 1 to 4, wherein the embossing elements are a deformable material.
7. The method of any one of claims 1 to 4, wherein the embossing elements of one of the rolls are steel and the embossing elements of the other roll are a deformable material.

FIG. 1

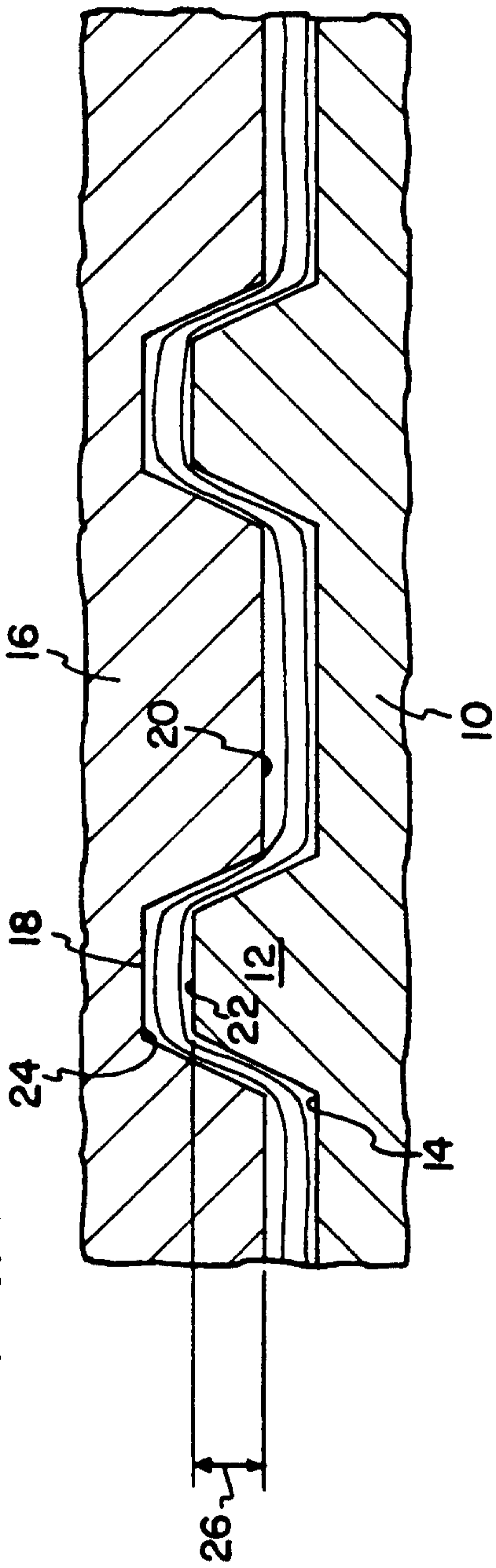

FIG. 2

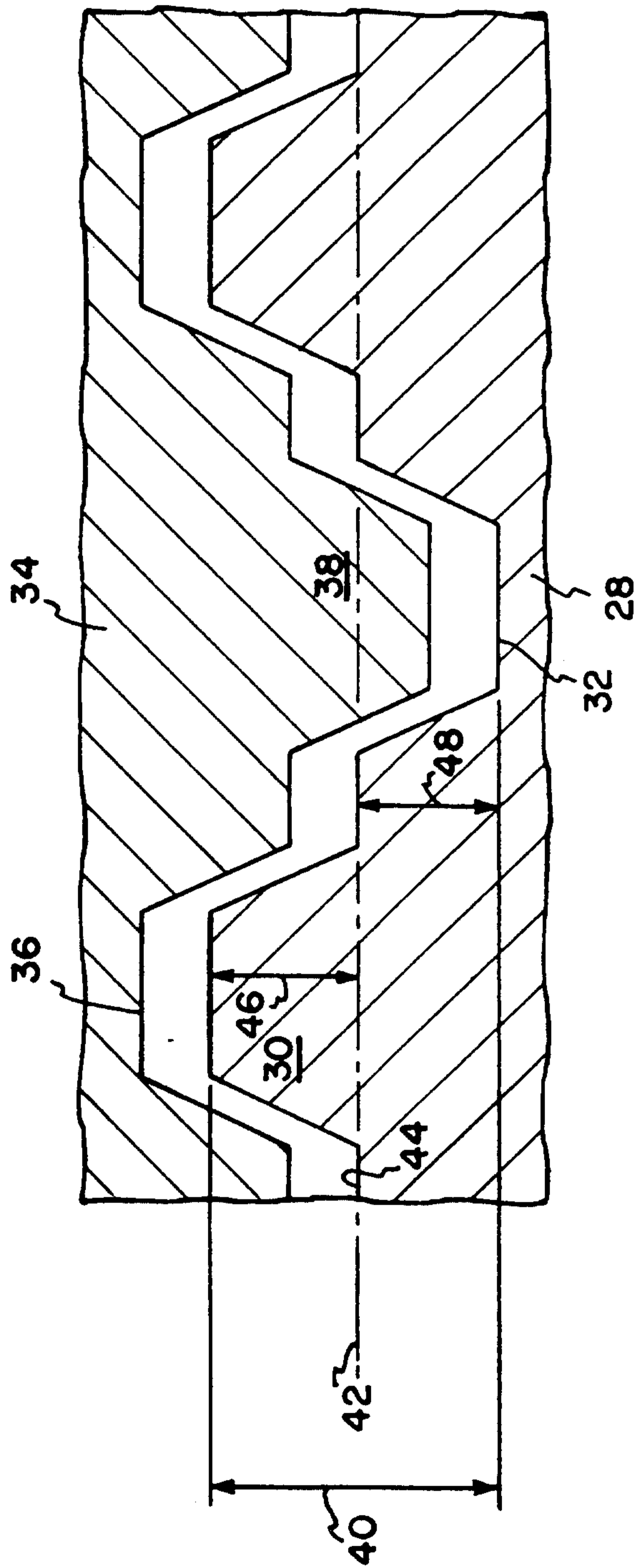

FIG. 3

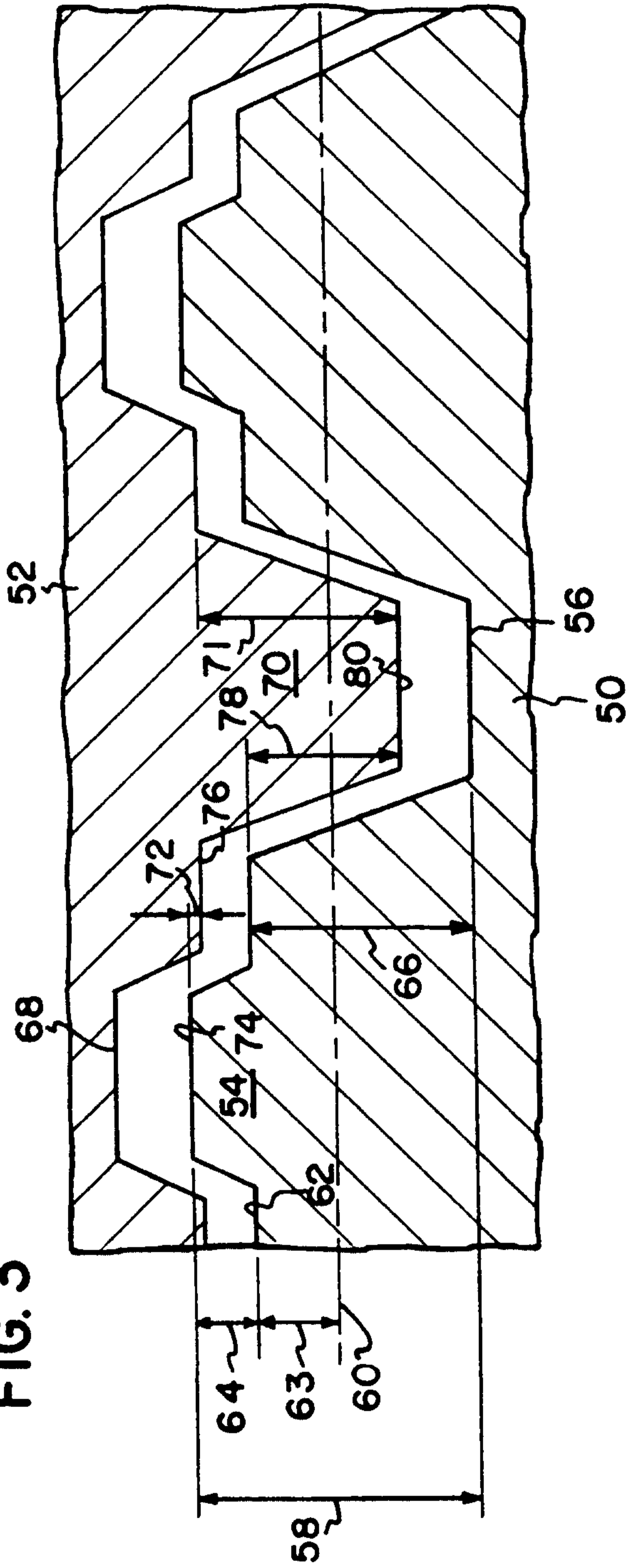

FIG. 4

