

[54] PRE-RECORDED CARTRIDGE VIDEO/AUDIO DISK

[75] Inventors: Osamu Tajima, Ayase; Takashi Yamamura, Yokohama; Yoichi Mita, Tokyo; Masafumi Mochizuki, Yamato, all of Japan

[73] Assignee: Victor Company of Japan, Limited, Yokohama, Japan

[**] Term: 14 Years

[21] Appl. No.: 166,781

[22] Filed: Jul. 7, 1980

[30] Foreign Application Priority Data Feb. 1, 1980 [JP] Japan 55-14482

[51] Int. Cl. D14-99; D16-05; D16-99

[52] U.S. Cl. D14/11; D3/35; D14/99

[58] Field of Search 206/444, 309, 303, 387; D3/35; D14/11, 99; 360/133, 99, 134, 135

[56] References Cited U.S. PATENT DOCUMENTS

Table with 4 columns: Patent No., Date, Inventor, and Classification. Rows include D. 245,125 (7/1977) Chou et al. (D3/35), D. 248,470 (7/1978) Talesfore (D14/11), D. 262,415 (12/1981) Gelardi et al. (D3/35), 4,159,827 (7/1979) Torrington (206/444 X), 4,164,782 (8/1979) Stewart (206/444 X), and 4,185,314 (1/1980) Hatchett et al. (206/444 X).

Primary Examiner—Bernard Ansher Attorney, Agent, or Firm—Cushman, Darby & Cushman

[57] CLAIM

The ornamental design for a pre-recorded cartridge video/audio disk, as shown and described.

DESCRIPTION

FIG. 1 is a top, front and right side perspective view of a pre-recorded cartridge video/audio disk showing my new design, FIG. 2 is a front elevational view, FIG. 3 is a rear elevational view, FIG. 4 is a right side elevational view, FIG. 5 is a left side elevational view thereof, FIG. 6 is a sectional view taken from line VI in FIG. 2, and FIG. 7 shows each perspective view of lid removed from cartridge, pre-recorded video/audio disk per se pulled out from cartridge, and case without lid and pre-recorded video/audio disk.

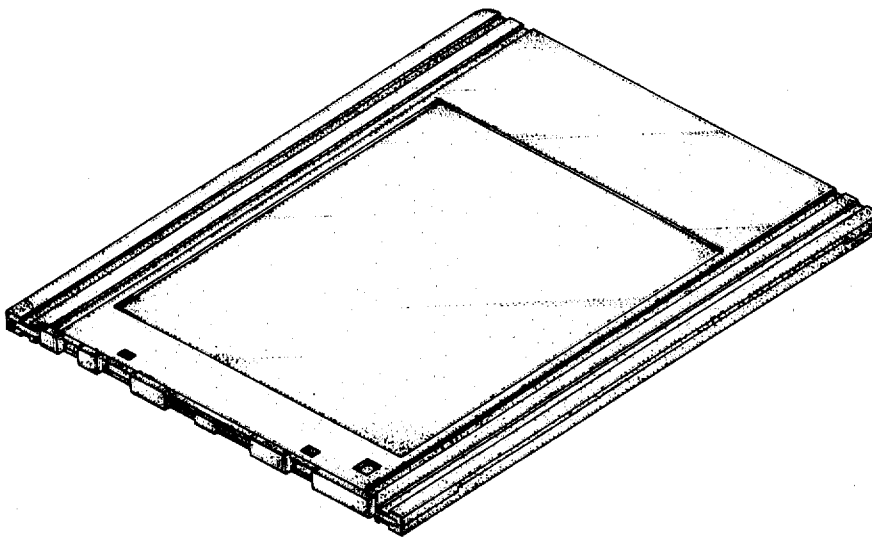

FIG. 1

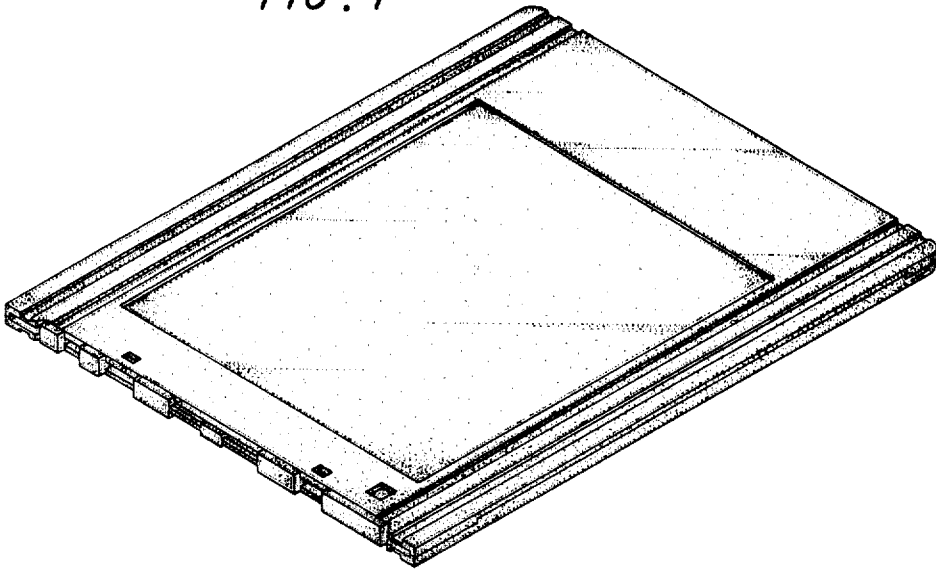

FIG. 2



FIG. 3

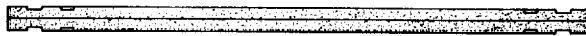

FIG. 4



FIG. 5



FIG. 6



FIG. 7

