

W. N. Whiteley. Harvester Rake.

N^o 86265

Patented Jan. 26, 1869.

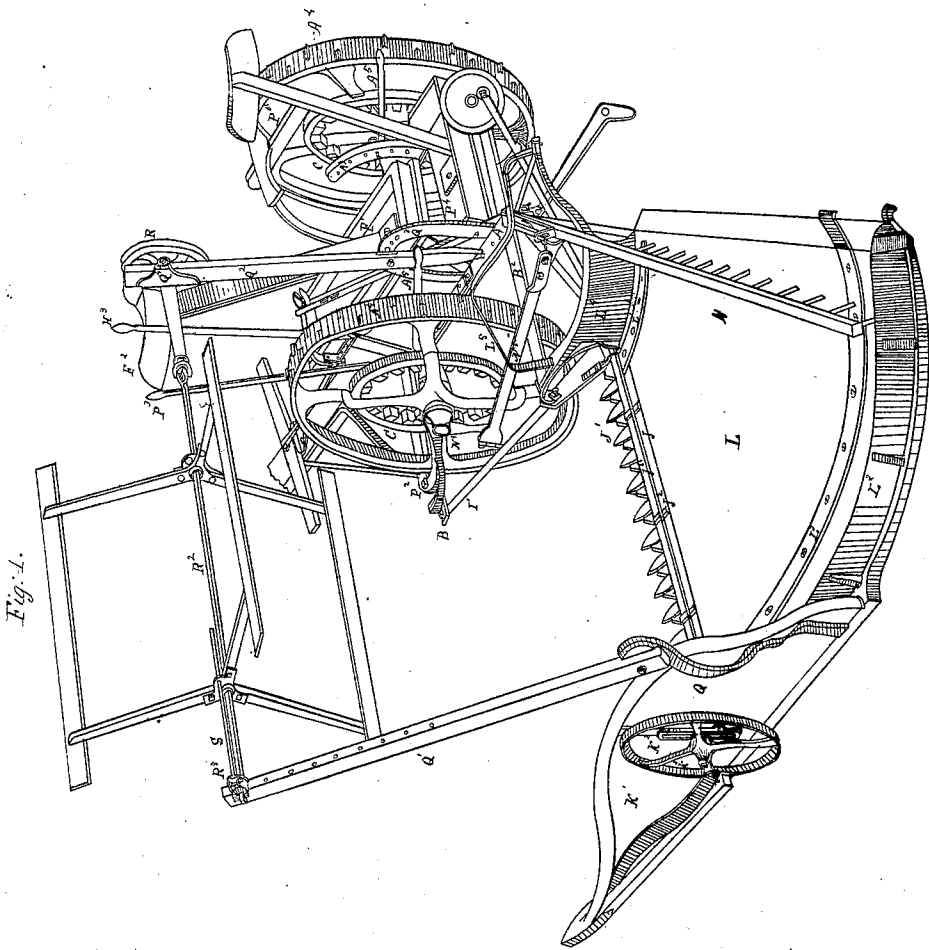

Fig. 1.

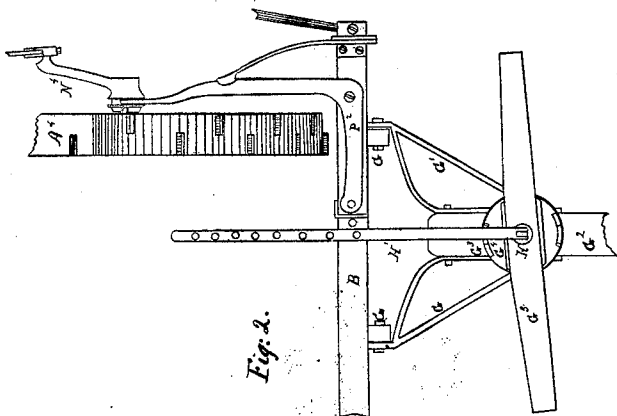

Fig. 2.

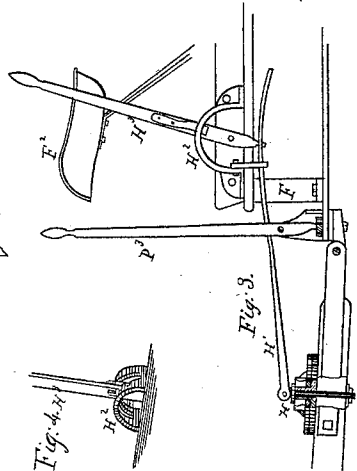

Fig. 3.

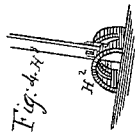

Fig. 4.

Witnesses.

J. Dennis
J. E. Dennis

Inventor

W. N. Whiteley

W. N. Whiteley.

Harvester Rake.

No 86265

Patented Jan. 26, 1869.

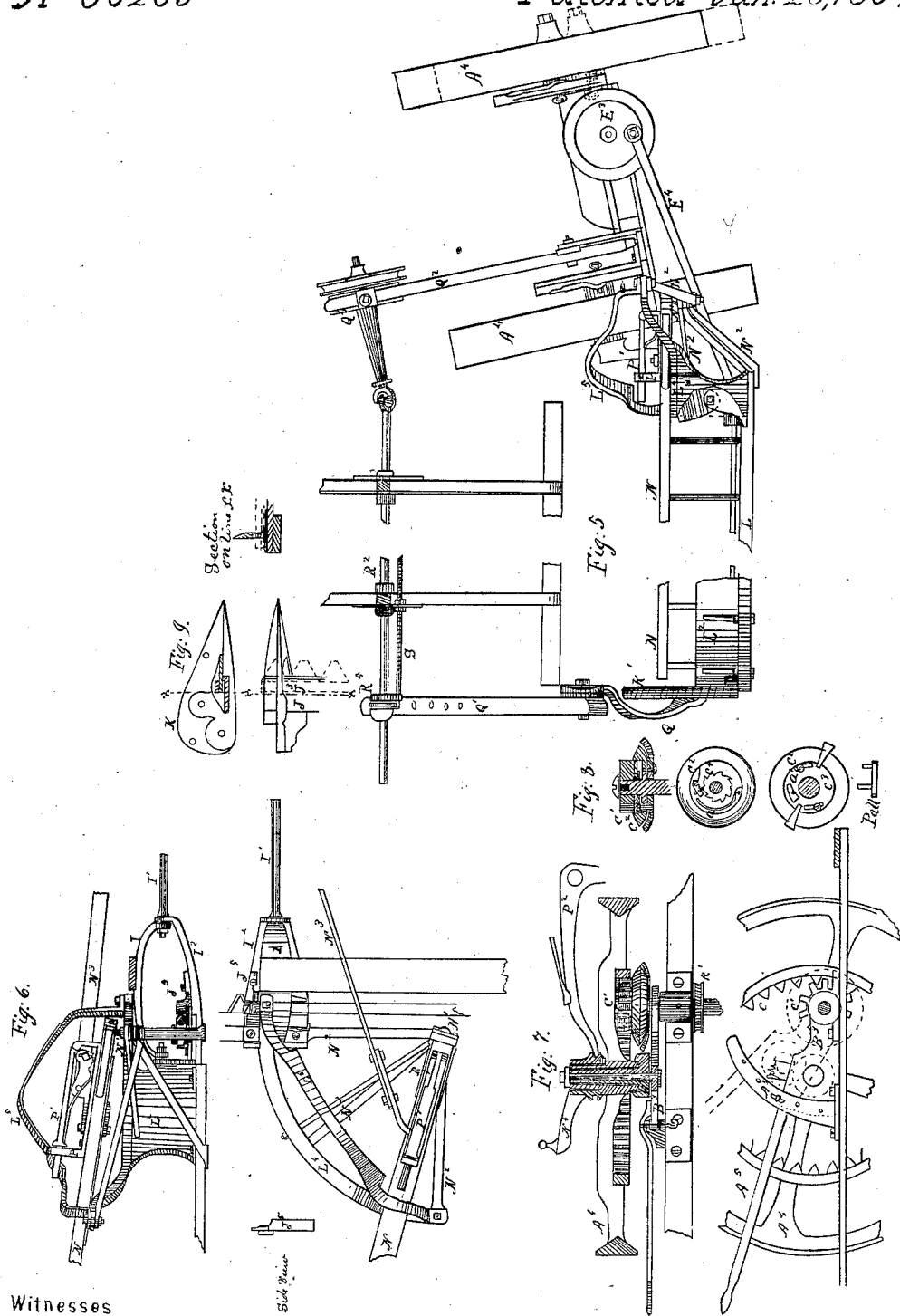

Witnesses

J. Dennis Jr.
J. E. Dennis

Inventor

W. N. Whiteley

UNITED STATES PATENT OFFICE.

WILLIAM N. WHITELEY, OF SPRINGFIELD, OHIO.

IMPROVEMENT IN HARVESTER-RAKES.

Specification forming part of Letters Patent No. 86,265, dated January 26, 1869.

To all whom it may concern:

Be it known that I, WILLIAM N. WHITELEY, of Springfield, in Clarke county, and State of Ohio, have invented certain new and useful Improvements in Harvesting-Machines for Harvesting Grain, Grass, &c.; and I do hereby declare that the same are described and represented in the following specification and accompanying drawings.

My improvements belong to that class of harvesting-machines in which the finger-bar is hinged to the main frame and projects out from it, known as "side-draft machines."

The nature of my invention is to make a combined self-raking reaper and mower with a hinged finger-bar and two driving and supporting wheels.

To enable others skilled in the art to make and use my improvements, I will proceed to describe their construction and operation, referring to the accompanying drawings, in which the same letters indicate like parts in each of the figures.

Figure 1 is a perspective view of the machine complete, as arranged for reaping, with self and hand raking attachment. Fig. 2 is a plan of the front of the frame and parts connected to it. Fig. 3 is a side elevation of the same. Fig. 4 is a perspective view of the stand H². Fig. 5, Sheet 2, shows the platform, rake, and reel horizontal and the main frame inclined. Fig. 6 shows a portion of the rake, with its arch or guide and beam with the supports of its pivot. Fig. 7 is a section and elevation of one of the driving-wheels, with the sector-plate and spindle on which it turns, and the rake-crank on the hub of the wheel. Fig. 8 is a section and elevation of the pinion and the devices for locking it to, and releasing it from, its shaft. Fig. 9 is an elevation, plan, and section of the shoe at the outer end of the finger-bar. Fig. 10, Sheet 3, shows the machine as a mower, with the reaping fixtures removed. Fig. 11 is a side elevation, showing the shoe and finger-bar on the ground and elevated. Fig. 12 is a plan of a portion of the machine arranged for mowing. Fig. 13 is a section of one of the levers which raises the finger-bar. Fig. 14 shows the machine with the finger-bar turned up and fastened, to travel from farm to farm, or elsewhere. Fig. 15 shows the rod which holds the finger-bar when it is turned

up. Fig. 16 is an elevation and plan of the main shoe and parts working in it.

In the accompanying drawings, A and A¹ are the side rails, and B the front bar; B¹, the center and B² the rear bar, which are firmly fastened to the under sides of the rails to form the main frame.

A² are boxes, fastened to the rails for the pinion-shaft A³ to turn in, as shown in Fig. 12.

B³ are sector-plates, which vibrate on the ends of the boxes A², and their rear ends traverse in grooves in the stands A³, fastened to the rails.

The hollow spindles B⁴, on which the driving and carrying wheels A⁴ turn, are fastened to the sector-plates by bolts, as shown in Fig. 7.

The wheels A⁴ are made in the form shown, with long hubs, one end of which turns in a groove in the hub of the spindle, and the treads of these wheels are provided with projections extending about halfway across, arranged alternately.

The levers A⁵ are fastened to the sector-plates, and the driver, by seizing one of the levers and working it up or down, can raise or lower the frame on either wheel; and the standards A³, in which the sector-plates traverse, are provided with a series of holes, in which pins may be inserted to hold the sectors and frame the required height.

The driving-gears C are fastened to the spokes of the wheels A⁴, and turn the pinions C¹, Figs. 7 and 8, which turn loose on the shaft A³, and are provided with ratchets C⁴ for the pawl fastened to the disk C², and pressed against the ratchet by the spring a, which disk C² is fastened to the shaft A³ to turn it and operate the cutters.

The disk C² has a recess in one side for the ratchet-pawl and spring, and a pin in the pawl extends through the disk into the slot a' in the plate C³ on the opposite side of the disk from the pinion, and the side of the slot a' next to the shaft is eccentric, and the plate C³ has two arms, by which it may be turned to raise the pawl and release the pinion to let the machine travel without operating the cutting apparatus. The pinion, disk, and plate, with the parts attached, are shown in Fig. 8 in plan and section.

The pinion-shaft A³ carries the bevel-gear E, which turns the pinion E¹, and shaft E²,

which turns in boxes fastened to the bars B' B'', and carries the fly-wheel E², which has a crank-pin in it for the link E⁴, which traverses the cutter-bar and cutters.

The brackets F are fastened to the rails A A¹, to support the foot-box F¹ for the driver; and in the bottom of the foot-box there is a long slot for the bolt which holds the spring of the driver's seat F², so that it may be set forward or back or adjusted; and when the machine is used for reaping, the seat is arranged as shown in Fig. 1. But when the machine is to be used for mowing, the spring is reversed in the box and the seat on the spring, and set in the position shown in Figs. 10 and 11.

The ears G are fastened to the front bar B, to carry the hounds G¹, which hold the tongue G², and the circular plate G³ is fastened to the tongue, and provided with lugs projecting into the scores in the plate G⁴, which turns on the top of G³, and has the double-tree G⁵ fastened to it. The lugs on the plate G³ and the scores in the plate G⁴ limit the vibration of a double-tree, and prevent one animal from drawing far ahead of the other.

The bolt H, which passes through the double-tree plates and tongue, has the link H¹ hinged to it, which extends back through a slot in the stand H², fastened to the side of the foot-box, and made in the form shown in the drawing in Figs. 3 and 4 for the lever H³ to work in, which vibrates on a bolt in the stand H² and traverses the link H¹, to raise and lower the rear of the frame and heel of the finger-bar.

There is a lug on the side of the lever H³, which catches in the scores in the arc of the stand H²; and there is a spring on the opposite side of the lever to press the lug into the scores, so that the driver can press the lever against the spring, and release the lug from the score and move it opposite the next or another score, and draw the lug into it without stopping the machine.

The front bar B and the rear bar B² extend out beyond the wheel A⁴ on the left side of the machine, to support the hanging bracket I, fastened to the under side of the latter, and connected to the former by the rod I¹, which forms the pivot for the fore end of the main shoe I². The rear end of this shoe vibrates on the bolt which connects it to the rear end of the hanging bracket I.

There is a score across the rear part of the shoe I², in which score the end of the finger-bar J is fastened, which finger-bar is provided with guard-fingers J¹ and brackets J², to hold the cutter-bar J³, which carries the cutters, the bar being operated by the link E⁴.

The stand J⁴ is fastened on top of the finger-bar in the shoe I². This stand and the top of the finger-bar form a groove for the heel of the cutter-bar to traverse in, which has a hole in it for the pivot on the link E⁴, and the bracket J⁵ is fastened to the shoe to hold the link to the cutter-bar, and hold and keep the

pivot in the hole in the cutter-bar while the machine is operated, and the finger and cutter bars vibrate and follow the undulations of the ground passed over, and also when the finger-bar is turned up to pass from one field to another.

The spring-stop J⁶ is fastened to the stand J⁴, to prevent the cutter-bar from slipping out when the finger-bar is turned up.

The shoe K is made of the form shown in Fig. 9, to surround the end of the finger-bar, and is fastened to it, and provided with a slot for the end of the cutter-bar and cutter to traverse through, against the side of which slot the cutter acts as against a guard-finger to cut the crop; and the rear of the slot is made so large as to leave an open space above and in rear of the cutter-bar for the escape of clogging matter, which, if retained, would bind the cutter-bar and prevent it from working freely.

The divider K¹ is made in the form shown, and fastened to the shoe K. The bolts which fasten the divider to the shoe also fasten the stand K², which carries the pivot of the grain-wheel K³, which wheel is made with a groove on the inside between the hub and rim, or with curved spokes, so that the end of the cutter-bar and cutter can work through the shoe into the groove or space between the hub and the rim of the wheel.

The platform L is made in the form shown, with its outer end fastened to the under side of the divider, which extends behind the finger-bar, by the plate L¹, as shown in the drawing.

L² is a curved guide-board, extending from the rear of the divider along the outer edge of the platform, to which it is fastened, to the rear edge of the platform. This board guides the grain, as it is raked off of the platform, so far from the standing grain as to be out of the path of the team in cutting the next swath.

L³ is a curved metal plate, fastened to the platform, for one of the outer teeth of the rake to traverse on and prevent the rake-teeth from wearing the platform. This plate extends from the finger-bar entirely across and beyond the rear edge of the platform, and the rear end curves over downward, so that the rake, if moved forward, would slip up over the end.

The rake arch or guide L⁴ is made in the form shown, and fastened to the inner end of the platform and to the shoe L², and the rake-bow L⁵ is arranged above the guide, with its ends fastened to the ends of the guide L⁴. N is the rake. It vibrates on the pivot N¹, which is a ball, and the box at the end of the rake is a socket, fitted to the ball of the pivot, so that the rake can rock and vibrate as required.

The pivot N¹ is supported by the brace-rods N²—one from the shoe or finger-bar, another from the platform, and the other two from different parts of the rake arch or guide, so that the pivot is moved by the finger-bar and the platform in all their vibrations.

The rake N is traversed by the link N³, which

connects it to the pin in crank N⁴ on the hub of the wheel A⁴, which turns the crank. The head of the crank-pin is a ball, and the box on the link is a socket, so that the link can rock and vibrate in working the rake.

The stand P is made in the form shown, and fastened to the rake, and carries the spring-latch P¹, which is hinged to one end of the stand, and vibrates in an upright slot in the other end, and is pressed up by a spring fastened to the stand under it. This latch P¹ passes over the rake-bow L⁵ when the rake moves forward, and raises and carries the rake up and over the cut and falling grain. Then the latch passes off of the bow, and the rake drops onto the rear of the finger-bar at the butts of the grain, when the crank moves the rake back on the arch or guide and over the platform, moving the grain-heads forward, sideways, and backward off the rear of the platform, and drops it so far from the standing grain that it is out of the path of the team in cutting the next swath. As the rake passes off the rear of the platform, it is raised up by the guide, and the teeth are lifted out of the gavel without tangling it. As the rake passed back, the spring-latch was pressed down by the rear of the bow, and passed out from under it, and was raised by the spring, so that as the rake moved forward the latch passed onto the beam and lifted the rake up, so as to carry it forward over the cut and falling grain, as before mentioned.

The crank N⁴ is fitted to turn and traverse on the hub of the wheel A⁴; and there is a score around the hub of the crank for the end of the bell-crank P², which vibrates on a pivot in the bar B, and is operated by the lever P³, which lever vibrates on a pivot in a stand fastened to the bar B. This lever P³ extends up near the driver's seat, so that the driver, while the machine is in operation, can traverse the crank on the hub of the wheel, and move one of the scores on the outer end of the crank-hub onto the clutch-pin in the wheel-hub, so that the wheel will turn the crank and operate the rake; and when it has removed the gavel, and while the rake is out of the way of the falling grain, the driver can traverse the crank from the clutch-pin, and let the rake remain at rest until sufficient grain has been cut to form another gavel, when he can traverse the crank and lock it again, and operate the rake to rake off the gavel, thus giving the driver the entire control of the rake, so that he can keep it constantly in operation by the machine, or make it operate at long or short intervals, to adapt it to the grain being cut by the machine.

P⁴ is the raker's foot-board, fastened to the rear of the frame; and P⁵, the raker's stand, from which the gavels may be raked off the platform by hand.

The reel-standard Q is fastened to the rear of the divider to support the reel-bearer Q¹, and the two are provided with two ratchet-plates, and connected by a bolt, so that the upper end of the bearer can be set higher or lower.

The lower end of the reel-standard Q² steps in the rail A, and it is supported by the curved stand Q³, fastened to the frame, and provided with a series of holes to adjust the standard. The box Q⁴ is fitted to traverse on this standard, and is fastened by a set-screw. This box has a long hollow hub on it for the short shaft to turn in, which short shaft has the pulley R on it, on which pulley runs a band to the pulley R¹ on the pinion-shaft.

The short shaft is connected to the reel-shaft R² by a flexible or universal joint, to allow the shaft to vibrate in connection with the finger-bar and platform. The reel-shaft R² is made square, and the centers of the reel-frame and the hollow journal or sleeve R³ are fitted to traverse on it. This journal is connected by a rod, S, to the reel-center, so as to traverse the reel on the shaft, and always hold it a proper distance from the bearer in all its vibrations.

When the gavels are to be raked from the platform by hand, the rake N, rake-bow L⁵, and link are all taken off or removed, so as to be out of the way of the hand-rake.

To convert this reaping-machine into a mower, the divider, platform, self-raking attachment, reel, and hand-raker's stand are removed, and the machine prepared for mowing by reversing the driver's seat and connecting the revolving track-clearer S¹ to the shoe K by a bolt, on which it vibrates, as shown in Fig. 10, the adjustable removable runner S² being applied to the shoe K by a bolt, so that it may be adjusted, attached, or detached whenever it is desirable. The object and purpose of this runner S² is to run over and press down tangled grass, so as to make it pass between the shoe and the finger next to the shoe, so that the cutters will sever the grass or swath cut from that which is left standing, so that the track-clearer will remove the grass which is cut from that which is left standing. Heretofore, in cutting tangled grass, this shoe would slip along under the grass cut, and it would remain attached to the standing grass, so that the track-clearer would slip along under the cut grass without removing it from that left standing, requiring a laborer to follow the machine and separate the cut from the uncut grass, to show the driver where to guide his team in cutting the next swath. Hence it is apparent that the runner S² saves the labor of one man to follow the machine and separate the cut from the uncut grass.

In mowing, the tongue may be left free to vibrate, and the points of the fingers may be raised by depressing the levers A⁵ and raising the front of the frame, which will permit the finger-bar and cutters to pass easily over rough ground.

To enable the driver, when mowing, to raise the outer end of the finger-bar, I hang the lever T on the heel of the shoe I², and connect it to the lever T', which vibrates on a bolt in the stand Q³, and extends forward near the driver's seat. The lever T' is provided with

as sliding bolt, (shown in Figs. 12 and 13,) which catches in a score in the edge of the stand Q^3 to hold the lever in position; and the driver, by seizing the lever and drawing the bolt can raise the lever T' and depress the lever T , which acts against a lug on the shoe to raise the finger-bar and cutters, and hold them the height required, as shown in Fig. 10; and the driver can, by means of the lever H^3 , depress the front and raise the rear of the frame with the cutting apparatus clear of the ground, as shown in Fig. 11.

It is proper to observe that the driving-wheels and the spindles on which they turn are entirely independent of each other, so that the driver can raise one side of the frame without the other by depressing one of the levers A^3 .

By turning up the finger-bar, as shown in Fig. 14, and connecting it to the rail A^1 by the brace-rod shown in Figs. 14 and 15, the machine will be mounted on its own wheels, in order to travel from farm to farm, or elsewhere.

Having thus described my improvements, what I claim is—

1. In a two-wheel hinged-bar harvester, a sweep-rake the support of which is rigidly braced to both finger-beam and platform, so as to conform to the movements of the latter, substantially as described.

2. The combination of a sweep-rake, a hinged finger-beam, a seat for the driver, and means for controlling the rake, so arranged that the driver can regulate the movements of the rake, substantially as described.

3. The combination of a sweep-rake, a platform having an outer rim to conform substantially to the sweep of the rake, a hinged finger-beam, and a support for the rake, rigidly attached to both finger-beam and platform, substantially as described.

WM. N. WHITELEY.

Witnesses:

J. DENNIS, Jr.,
DANL. ROWLAND.