

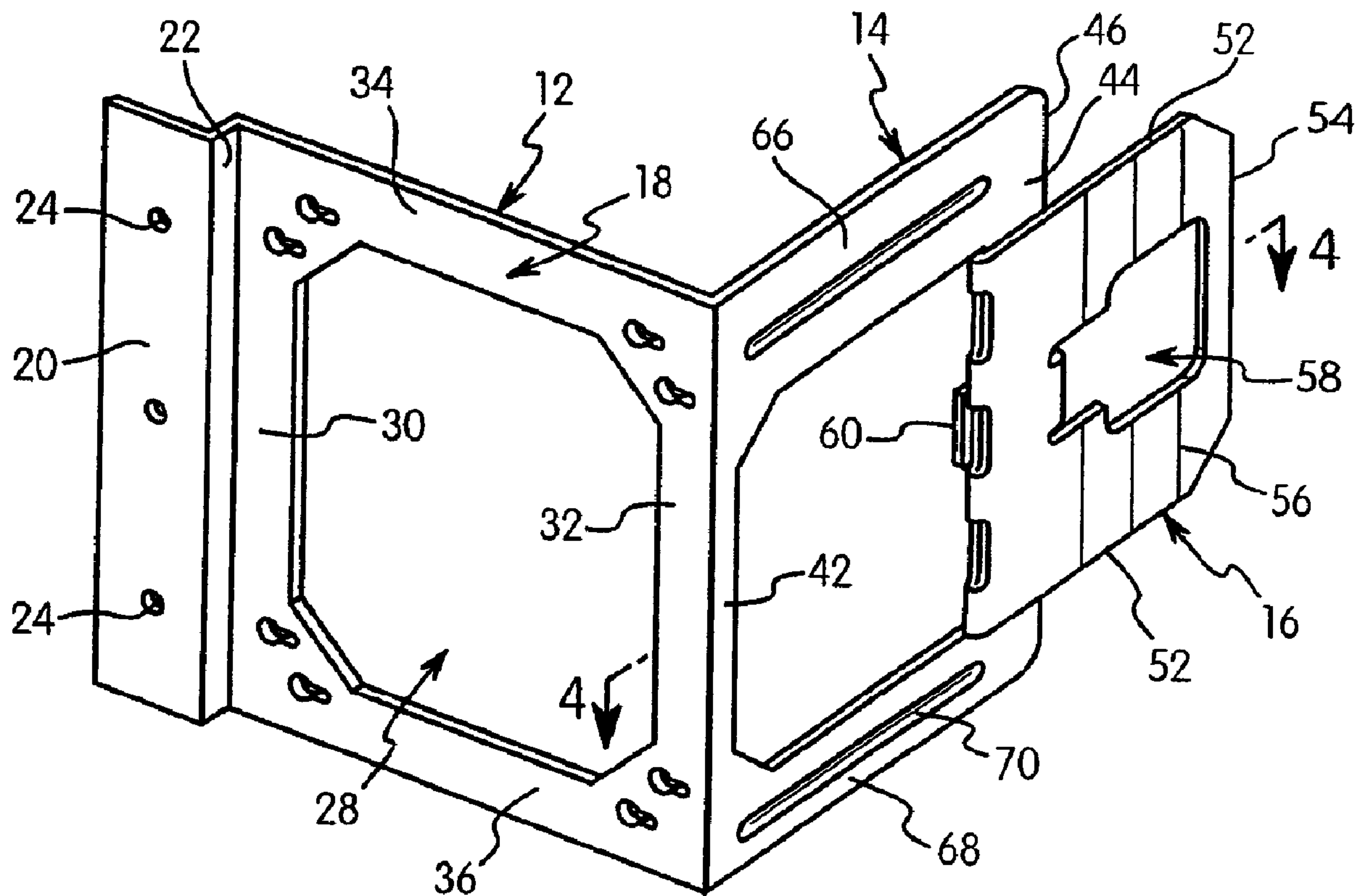

(22) Date de dépôt/Filing Date: 2007/02/07  
 (41) Mise à la disp. pub./Open to Public Insp.: 2007/08/23  
 (45) Date de délivrance/Issue Date: 2012/10/23  
 (30) Priorité/Priority: 2006/02/23 (US11/359,768)

(51) Cl.Int./Int.Cl. *H02G 3/02* (2006.01),  
*H02G 3/08* (2006.01)  
 (72) Inventeur/Inventor:  
JOHNSON, STEVEN J., US  
 (73) Propriétaire/Owner:  
HUBBELL INCORPORATED, US  
 (74) Agent: FINLAYSON & SINGLEHURST

(54) Titre : SUPPORT DE FIXATION REGLABLE  
 (54) Title: ADJUSTABLE MOUNTING BRACKET



(57) Abrégé/Abstract:

A mounting bracket for supporting an electrical box or other electrical device to a wall stud is adapted to contact an opposing wall to resist movement of the bracket. The bracket includes a front plate and a support plate extending perpendicular to the front plate and having a length to engage the opposing wall. The extension plate is integrally formed with the support plate and can be folded to an outward extended position to increase the effective length of the stabilizing plate to accommodate wall cavities of different depths. The extension plate includes fold lines so that an end portion can be bent to shorten the effective length of the extension plate.



**Abstract of the Disclosure**

A mounting bracket for supporting an electrical box or other electrical device to a wall stud is adapted to contact an opposing wall to resist movement of the bracket. The bracket includes a front plate and a support plate extending perpendicular to the front plate and having a length to engage the opposing wall. The extension plate is integrally formed with the support plate and can be folded to an outward extended position to increase the effective length of the stabilizing plate to accommodate wall cavities of different depths. The extension plate includes fold lines so that an end portion can be bent to shorten the effective length of the extension plate.

## ADJUSTABLE MOUNTING BRACKET

### **Field of the Invention**

**[0001]** The present invention is directed to a mounting bracket for an electrical box or other electrical component. The invention is particularly directed to an adjustable mounting bracket for accommodating wall cavities of different depths between opposing walls.

### **Background of the Invention**

**[0002]** Electrical boxes are commonly mounted on various mounting brackets for securing the electrical box to a wall stud or other support. The electrical boxes are dimensioned to support electrical receptacles, switches and other components and must be securely mounted to the wall stud. Many electrical boxes include a mounting bracket extending from one side of the electrical box so that only one side of the electrical box is supported by the bracket. The opposite side of the electrical box often does not include a support so that some movement of the electrical box can occur during use.

**[0003]** To provide support of opposite ends of the electrical box, a number of brackets have been proposed. Typically, the bracket includes a first member for attaching to a wall stud and a second member connected to the opposite side of the box so that both sides of the electrical box are supported to resist movement with respect to the wall.

**[0004]** One example of a prior support bracket is disclosed in U.S. Patent No. 4,399,922 to Horsley. The bracket as disclosed includes an extension arm bent at a right angle to a plate that supports the electrical box. The plate has one side edge provided with holes for securing the plate to a wall stud. The extension arm is formed on the opposite end and has a length to contact a wall on the other side of the wall stud. The extension member includes a series of score lines that can be broken off for use with walls having different depths.

**[0005]** Another device is disclosed in U.S. Patent No. 4,732,356 to Medlin. This device also includes a plate member for supporting an electrical box. The plate includes a first end portion for attaching to the wall stud and a second end portion having an L-shaped arm to contact the opposite wall. A separate extension plate is attached to the L-shaped arm to adjust the length of the arm for different depths between the walls.

**[0006]** U.S. Patent No. 4,688,693 to Medlin discloses an outlet box stabilizer bracket having an extension formed at a right angle to the bracket to contact an opposing wall. The extension is cut from the bracket and bent from the bracket to form a central opening in the bracket.

**[0007]** U.S. Patent No. 4,964,525 to Coffey et al. discloses an electrical box mounting bracket for connecting to a wall stud. The

bracket includes a pair of side mounted support legs that are bent at a right angle from the bracket to engage the opposite wall.

**[0008]** Examples of other mounting brackets that contact the opposing wall are disclosed in U.S. Patent No. 4,645,089 to Horsley, U.S. Patent No. 4,533,060 to Medlin, U.S. Patent No. 4,569,458 to Horsley, U.S. Patent No. 4,572,391 to Medlin, and U.S. Patent No. 4,603,789 to Medlin.

**[0009]** While the devices and brackets have been generally suitable for the intended purpose of supporting an electrical box, there is a continuing need in the industry for improved support brackets and methods of producing the brackets.

#### **Summary of the Invention**

**[0010]** The present invention is directed to a mounting bracket for supporting an electrical box or other electrical component. In particular, the invention is directed to a mounting bracket for mounting an electrical component to a wall stud or other support.

**[0011]** A primary feature of the invention is to provide a mounting bracket for an electrical box or electrical component formed as a unitary one piece member. In one embodiment, the mounting bracket is formed from a sheet material such as steel that can be folded to a shape to support the electrical box or electrical component.

**[0012]** Another feature of the invention is to provide an electrical outlet box bracket that is attached to a wall stud and is able to support an electrical box by contacting an opposing wall.

**[0013]** A further feature of the invention is to provide a bracket for supporting an electrical box where the bracket has a support plate to contact an opposing wall and where the support plate can accommodate wall cavities of different depths. One end of the bracket

can be attached to a wall stud or other support member while the support plate supports the opposite end to resist bending of the bracket.

**[0014]** Still another feature of the invention is to provide a bracket for supporting an electrical box where the bracket includes a support plate and an integrally formed extension plate. The extension plate can be folded in a generally outward direction with respect to the support plate to contact an opposing wall to support the electrical box.

**[0015]** A further feature of the invention is to provide a bracket for supporting an electrical box and mounting the electrical box to a wall stud. The bracket has a support plate extending at a right angle to the bracket and has a length to contact an opposing wall to support the bracket and resist movement of the bracket and the electrical box with respect to the wall stud. An extension plate is integrally formed with the support plate and can be folded outwardly to an extended position for contacting an opposing wall in a deep wall cavity so that the bracket can accommodate wall cavities of different depths. The extension plate can be cut from the support plate and folded outwardly to form a central opening with the support plate. In another embodiment, the extension plate has at least one and preferably two legs cut from the support plate which can be folded outwardly. In preferred embodiments, the extension plate has a bendable locking tab that can be folded over a portion of the support plate to lock the extension plate in the extended position.

**[0016]** These and other features of the invention are basically attained by providing an adjustable outlet box mounting bracket formed from a unitary piece of stiff sheet material. The bracket

comprises a front mounting panel having a substantially planar portion with a central opening with a dimension to accommodate an electrical outlet box. The front mounting panel having a front surface facing in a direction perpendicular to a plane of the front mounting panel and surrounding the central opening. A plurality of first openings receive screw heads for coupling the front mounting plate to the electrical outlet box. A plurality of second openings receive fasteners for mounting the front mounting panel to a wall stud. A stabilizing plate extends from the front mounting panel at a right angle, in a direction opposite to the front surface, and has a first end connected to the front mounting panel and a second end to engage an opposing wall surface spaced from a front wall a first distance during use. An extension plate, having an inner end, is coupled to the stabilizing plate at the second end by a fold line. The plate is bendable about the fold line from a retracted first position to a second extended position extending away from the stabilizing plate. The extension plate has a first end, a second end and an outer end for engaging an opposing wall surface, which is spaced from the front wall by a second distance, when the extension plate is in the second extended position.

**[0017]** The various aspects of the invention are further attained by providing an electrical box mounting bracket which comprises a front mounting panel having a central opening with a dimension to accommodate an electrical box. A plurality of first openings receive screw heads for attaching the electrical box to the front mounting panel. A plurality of second openings receive fasteners for mounting the front mounting panel to a wall stud. A stabilizing plate has a first end coupled to and extending from the front mounting panel and

having a second end to engage a first opposing wall surface spaced from a front wall a first distance during use. An extension plate is coupled to the stabilizing plate about a first fold line and is bendable from a first position to an extended second position to engage a second opposing wall surface spaced from the front wall a second distance. A bendable locking tab is integrally formed with the bracket to secure the extension plate in the extended position.

**[0018]** The features of the invention are also attained by providing an electrical box mounting bracket assembly which comprises a front mounting panel having a central opening with a dimension to accommodate an electrical box. A plurality of first openings receives screw heads for coupling the electrical box to the front mounting plate and a plurality of second openings for fasteners for mounting the front mounting panel to the wall stud. The electrical box is coupled to the front mounting panel such that the opening in the electrical box is aligned with the central opening of the front mounting panel. A stabilizing plate is coupled to a side of the front mounting panel and is bendable about a fold line to an extended position wherein an outer end of the stabilizing plate engages an opposing wall surface spaced from a front wall a first distance during use. The stabilizing plate has a central opening with a first inner edge at its first end and a second inner edge at its second outer end. An extension plate is integrally formed with the stabilizing plate and has a first end portion and a second end portion coupled to the outer end of the stabilizing plate by a fold line and a second end portion spaced from the first end portion. The extension plate is bendable about the fold line between a first retracted position and a second extended position. The second end portion extends away from the front mounting plate to engage an

**[0019]** opposing wall surface spaced from the front wall by a second distance during use, where the second distance is greater than the first distance.

**[0020]** These and other aspects and features of the invention will become apparent from the following detailed description of the invention which taken in conjunction with the annexed drawings will become apparent to one skilled in the art.

### **BRIEF DESCRIPTION OF THE DRAWINGS**

**[0021]** The following is a brief description of the drawings, in which:

**[0022]** FIG. 1 is a perspective view of the mounting bracket in a first embodiment of the invention showing the stabilizing plate and extension plate;

**[0023]** FIG. 2 is a top end view of the stabilizing plate of FIG. 1 with the extension plate in a first position and showing the wall structure;

- [0023]** Figure 3 is a perspective view of the mounting bracket of Figure 1 showing the extension plate in a second extended position;
- [0024]** Figure 4 is a cross-sectional view of the mounting bracket of Figure 1 taken along line 4-4 of Figure 3 showing the locking tab coupled to the support plate;
- [0025]** Figure 5 is an end view of the mounting bracket of Figure 1 showing the extension plate in the extended position contacting a wall;
- [0026]** Figure 6 is an end view of the mounting bracket of Figure 1 showing the extension plate in a shortened form to contact a wall;
- [0027]** Figure 7 is a top plan view of a cut blank for forming a mounting bracket in a second embodiment of the invention;
- [0028]** Figure 8 is an end view of the bracket of Figure 7;
- [0029]** Figure 9 is a perspective view of the folded bracket of Figure 7;
- [0030]** Figure 10 is an end view of the folded bracket of Figure 7 showing the stabilizing plate contacting an opposing wall;
- [0031]** Figure 11 is a perspective view of the mounting bracket of Figure 7 showing the extension plate in the extended position;
- [0032]** Figure 12 is a partial cross-sectional view of the locking tab folded over the stabilizing plate; and
- [0033]** Figure 13 is an end view of the mounting bracket attached to a wall stud and showing the extension plate in the extended position.

#### **Detailed Description of the Invention**

**[0034]** The present invention is directed to a mounting bracket for an electrical box or other electrical device. In particular, the invention is directed to a mounting bracket for securing an electrical box to a wall stud and supporting the electrical box in a secure manner.

**[0035]** Referring to the drawings, a first embodiment of the invention is shown in Figures 1-6. As shown in Figure 1, the mounting bracket 10 includes a front mounting plate 12, a support plate 14 and an extension plate 16.

**[0036]** Mounting bracket 10 in a preferred embodiment of the invention is formed from a single piece of sheet material having sufficient strength to support an electrical box during use. Typically, mounting bracket 10 is formed from a steel sheet that is cut, stamped or pierced to form a one piece unitary unit. As shown in Figure 1, front mounting plate 12 has a substantially flat front face 18 and a side portion 20 offset from the front face 18 by a stepped portion 22. Side portion 20 in the embodiment shown has a substantially rectangular shape with a plurality of apertures 24 for receiving fasteners for securing mounting bracket 10 to a wall stud 26 or other support shown in Figure 1. Front mounting plate 12 has a central opening 28 having a dimension to receive an electrical box or other electrical component. Central opening 28 defines first and second side sections 30 and 32. Top section 34 and bottom section 36 extend between side sections 30 and 32 to define the opening 28. Front face 18 includes a plurality of apertures 38 for receiving screws or other fasteners for attaching an electrical box 40 to front plate 12 as shown in Figure 2.

**[0037]** Support plate 14 in the embodiment of Figures 1-8 extends substantially perpendicular to front plate 12 in a direction away from front face 18. Support plate 14 has a first inner section 42 connected to side section 32 of front plate 12. Support plate 14 has a second end section 44 forming an outer end 46 spaced from front plate 12.

**[0038]** Extension plate 16 is integrally formed with support plate 14 and is cut or stamped from support plate 14 as shown in Figure 1. A

plurality of elongated apertures 48 are pierced in support plate 14 to define a fold line 50 between support plate 14 and extension plate 16. Extension plate 16 has side edges 52 and an outer edge 54 as shown in Figure 3. A plurality of spaced apart score lines that define fold lines 56 are formed in extension plate 16 that are substantially parallel to fold line 50. Fold lines 56 are typically formed by stamping so that portions of extension plate 16 can be folded to reduce the effective length of extension plate 16. A central opening 58 is formed in extension plate 16 by cutting or stamping. In the embodiment illustrated, a locking tab 60 is cut from central opening 58 into extension plate 16 in a direction toward fold line 50 as shown in Figure 1. Locking tab 60 includes side edges 62 and an outer edge 64. Extension plate 16 is cut to form top and bottom sections 66 and 68, respectively, in support plate 14 that extend in a direction substantially perpendicular to front plate 12. An embossed strengthening rib 70 is formed in each top and bottom section 66 and 68 to strengthen support plate 14 and resist bending or buckling.

**[0039]** In use, electrical box 40 is coupled to front plate 12 and side portion 20 is attached to wall stud 26. Wall stud 26 supports a front wall 27 in phantom lines that overlies mounting bracket 10 in a conventional manner. An opposing rear wall 72 is attached to wall stud 26 on a side opposite mounting bracket 10. Referring to Figure 2, wall stud 26 has a dimension indicated by arrow 74. Support plate 14 has a length extending from front plate 12 corresponding substantially to the dimension of wall stud 26 so that the end 46 of support plate 14 contacts wall 72 to stabilize one end of the front plate 12. Mounting bracket 10 is cantilevered from wall stud 26 by side portion 20. To prevent front plate 12 from flexing or bending in a

direction toward wall 72, support plate 14 has a dimension to contact wall 72 and support mounting bracket 10.

**[0040]** Mounting bracket 10 is able to accommodate wall structures having different depths by selectively adjusting the effective length of support plate 14. For example, opposing wall 72 can be spaced a distance greater than the distance 74 shown in Figure 2. Referring to Figure 5, a wall stud 26 indicated by arrow 76 where opposing wall 72 is spaced from a front wall a distance greater than the length of support plate 14. In this embodiment, extension plate 16 is folded outwardly from support plate 14 along fold line 50 from a first position shown in Figure 1 to a second position shown in Figure 3 where extension plate 16 extends away from support plate 14. In the illustrated embodiment, extension plate 16 is folded flat against support plate 14 to be parallel thereto. As shown in Figure 3, outer edge 54 of extension plate 16 is spaced from front plate 12 a distance to accommodate the depth of a wall cavity as shown in Figure 5. As shown in the cross-section of Figure 4, locking tab 60 is folded over the outer end 46 of support plate 14 to effectively lock extension plate 16 in an extended position with respect to support plate 14. As shown in Figure 5, extension plate 16 effectively increases the length of support plate 14 to engage the opposing wall 72 to prevent flexing of the front plate 12 and movement of the electrical box during use.

**[0041]** Referring to Figure 6, wall stud 26 can have a dimension indicated by arrow 78 that is less than the dimension 76 of wall stud 26 of Figure 5. The wall stud 26 shown in Figure 6 having the dimension indicated by arrow 78 forms a wall cavity having a dimension less than the combined length of support plate 14 and extension plate 16 when folded to the extended position. As shown in Figure 6, extension plate 16 can be folded along one of the fold lines

56 to effectively shorten the length of extension plate 16 so that the folded portion of the extension plate contacts the opposing wall 72 while it supports front plate 12 in a position substantially parallel to opposing wall 72.

**[0042]** In the embodiment of Figures 1-6, mounting bracket 10 is able to accommodate wall structures having different cavity depths by folding the extension plate outwardly and where necessary folding the extension plate about the fold lines to reduce the overall length of the support plate and extension plate. In one preferred embodiment, support plate 14 has a length corresponding to the minimum depth of a standard wall structure which can be, for example, about 3.5 inches. In wall structures having a depth greater than the length of the support, the extension plate is folded outward and locked into place so that the end of the extension plate can contact the opposing wall. In the event the depth of the wall cavity is less than the combined length of the support plate and the extension plate, the effective length of the extension plate can be reduced by folding along one or more of the fold lines. The resulting tab formed by folding the extension plate along the fold line can be folded 90° as shown in the drawings or folded 180° to lay flat against the support plate or extension plate.

**[0043]** The locking tab as shown in the illustrated embodiment is integrally formed with the structure and folded over to clamp the extension plate in the extended position with respect to the support plate. In the illustrated embodiment, the locking tab is cut from the extension plate and positioned to fold over the outer end of the support plate. In alternative embodiments, the locking tab is formed with the support plate which can be folded over the extension plate to lock the extension plate in the extended position. In another

embodiment, a separate fastener, clip or locking member can be coupled to the extension plate and/or support plate to lock the extension plate in the extended position.

**Embodiment of Figures 7-13**

**[0044]** In a second embodiment of the invention, a mounting bracket 90 is formed from a cut or stamped blank of sheet material as shown in Figure 7. Mounting bracket 90 includes a front plate 92 defining a front mounting panel, a support plate 94 and an extension plate 96. As shown in Figure 7, front plate 92, support plate 94 and extension plate 96 are integrally formed and connected together by fold lines as discussed hereinafter in greater detail.

**[0045]** Front plate 92 includes a front face 98 and a side portion 100 connected to front face 98 by a stepped portion 102 to offset front face 98 with respect to side portion 100. Side portion 100 includes a plurality of holes 104 for receiving fasteners to attach side portion 100 to a wall stud or other support surface. Front face 98 includes a plurality of holes 106 for receiving fasteners for coupling an electrical box to front mounting plate 92.

**[0046]** Support plate 94 and extension plate 96 are cut from the blank and bent outwardly from front plate 92 as shown in Figure 9 to form a central opening 108. Central opening 108 has a dimension to accommodate the electrical box 110 and defines first and second side sections 112 and 114. A top section 116 and a bottom section 118 extend between side sections 112 and 114 as shown in Figure 9.

**[0047]** Support plate 94 is connected to the inner edge 120 of central opening 108 alongside section 114. Elongated slots 122 define a fold line between side section 114 and support plate 94 as shown in Figure 7. Support plate 94 includes a central opening 124 to define a

pair of legs 126 and an outer end portion 128. Embossed ribs 130 are formed along the length of legs 126 to strengthen legs 126 during use. Outer end portion 128 has an outer edge 132.

**[0048]** Extension plate 96 is integrally formed with support plate 94 and coupled to outer edge 132 of extension plate 96. Elongated slots 134 are formed to define a fold line 136 between support plate 94 and extension plate 96. Extension plate 96 in this embodiment includes an end portion 138 and a pair of legs 140 extending from end portion 138. Legs 140 are cut from the blank adjacent legs 126 of support plate 94 as shown in Figure 7. End portion 138 is connected to support plate 94 along fold line 136. End portion 138 includes an edge 140 having a locking tab 144 cut from end portion 138. Locking tab 144 is connected to end portion 138 by a fold line 146 and includes side edges 148 and an outer edge 150.

**[0049]** In use, mounting bracket 90 is folded to the position shown in Figure 9 where support plate 94 is substantially perpendicular to front plate 92 and extension plate 96 is folded with respect to support plate 94 to be substantially parallel with front plate 92 and perpendicular to support plate 94. Bending support plate 94 and extension plate 96 forms central opening 108 as shown in Figure 9 to allow the electrical box 110 to be coupled to front plate 92 and to allow access to the interior of electrical box 110. As shown in Figure 10, side portion 100 of front plate 92 is attached to a wall stud 152 by suitable fasteners such as nails or screws. As in the previous embodiment, wall stud 152 supports a front wall (not shown) and an opposing wall 154 as shown in Figure 10. As shown in Figure 10, support plate 94 has a length substantially equal to the dimension of wall stud 152. In this manner, the outer edge 132 of support plate 94 and the face of extension plate 94 contact opposing wall 154 to

support the end of mounting bracket 90 and prevent bending or flexing of front plate 92 with respect to side portion 100 and wall stud 152.

**[0050]** As in the previous embodiment, mounting bracket 90 is able to accommodate a wall cavity having different depths and dimensions. Referring to Figure 11, extension plate 96 is folded along fold line 136 so that extension plate 96 is substantially parallel to support plate 94. As shown in Figure 12, locking tab 144 is folded along fold line 146 over the inner edge of outer end portion 128 to secure extension plate 96 in an extended position with respect to support plate 94. As shown in Figure 13, the combined length of support plate 94 and extension plate 96 complements the dimension of wall stud 152 so that an outer end 156 of legs 140 contact opposing wall 154 to support mounting bracket 90. As in the previous embodiment, legs 140 include a plurality of spaced-apart fold lines so that the effective length of extension plate 96 can be shortened to accommodate the dimension of the wall cavity defined by the opposing wall 154 and wall stud 152 by bending legs 140 along the selected fold line 158. The extension plate 96 is shortened in a manner similar to the previous embodiment by folding along the fold lines 158. The resulting tab can be folded to be perpendicular to the extension plate or folded parallel to the extension plate.

**[0051]** While various embodiments have been chosen to illustrate the invention, it will be understood by those skilled in the art that various changes and modifications can be made without departing from the scope of the invention as defined in the appended claims.

**WHAT IS CLAIMED IS:**

1. An adjustable outlet box mounting bracket formed from a unitary piece of stiff sheet material, said bracket comprising:
  - a front mounting panel having a substantially planar portion with a central opening with a dimension to accommodate an electrical outlet and an electrical box, said front mounting panel having a front surface facing in a direction perpendicular to a plane of said front mounting panel and surrounding said central opening, a rear side, a plurality of first openings in said front mounting panel for receiving screws adapted for coupling the electrical outlet box to said rear side of said front mounting panel in alignment with said central opening, and a plurality of second openings for receiving fasteners for mounting said front mounting panel to a wall stud;
  - a stabilizing plate extending from said front mounting panel at a right angle in a direction opposite to said front surface and having a first end connected to said front mounting panel and a second end to engage an opposing wall surface spaced from said front mounting panel a first distance during use; and
  - an extension plate having an inner end coupled to said stabilizing plate at said second end by a fold line and being bendable about the fold line from a retracted first position to a second extended position extending away from said stabilizing plate, said extension plate having an outer end for engaging an opposing wall surface spaced from said front mounting plate a second distance when said extension plate is in said second extended position.
  
2. The mounting bracket of claim 1, wherein
  - said front mounting panel has a first side portion and a second side portion opposite said first side portion, and wherein said central opening is positioned between said first side portion and said second side portion and said second openings are formed in said first side portion and said stabilizing plate is coupled to said second side portion.

3. The mounting bracket of claim 2, wherein  
said second side portion has an outer edge and wherein said stabilizing plate is coupled to said outer edge.
4. The mounting bracket of claim 1, wherein  
said extension plate is removed from said stabilizing plate to define an opening in said stabilizing plate, and where said extension plate is integrally formed with an outer edge of said opening in said stabilizing plate and foldable outwardly to the extended position.
5. The mounting bracket of claim 4, wherein  
said extension plate includes a cut portion defining an integrally formed locking tab and being bendable to couple to said second end of said stabilizing plate to retain said extension plate in said extended position.
6. The mounting bracket of claim 5, wherein  
said extension plate has a central opening, and wherein said locking tab is formed by cuts extending outwardly from said central opening in said extension plate.
7. The mounting bracket of claim 5, wherein  
said locking tab is bendable to bend over said second end of said stabilizing plate to fix said extension plate in an extended position with respect to said stabilizing plate.
8. The mounting bracket of claim 1, wherein  
said outer end of said extension plate includes a plurality of parallel score lines adaptable to be folded to shorten said extension plate to a desired length.
9. The mounting bracket of claim 1, wherein

said fold line is positioned between an outer edge of said stabilizing plate and an inner edge of a first portion of said extension plate.

10. The mounting bracket of claim 1, wherein

said extension plate is substantially parallel to said front mounting panel in said first position and substantially perpendicular to said front mounting panel in said second position.

11. The mounting bracket of claim 10, wherein

said extension plate includes an integral locking tab proximate said inner end of said extension plate, said locking tab being bendable to couple to said stabilizing plate to secure said extension plate in said second position.

12. The mounting bracket of claim 1, wherein

said extension plate is substantially parallel to said stabilizing plate when in said second extended position.

13. The mounting bracket of claim 1, further comprising a locking member for locking said stabilizing plate and said extension plate together in said second extended position with said outer end of said extension plate extending outwardly from said stabilizing plate.

14. The mounting bracket of claim 1, wherein

said outer end of said extension plate extends toward said front mounting panel when said extension plate is in said first position and said outer end of said extension plate extends away from said front mounting panel when in said second position.

15. The mounting bracket of claim 14, wherein

said stabilizing plate includes a cut portion to define a central opening in said stabilizing plate, said central opening in said stabilizing plate having a first

inner edge adjacent said front mounting plate and a second inner edge adjacent said second end of said stabilizing plate, and where said fold line is formed between said second inner edge and an inner end of said extension plate.

16. The mounting bracket of claim 15, wherein

said extension plate has a cut portion defining a locking tab spaced from an inner edge and said outer edge of said extension plate, said locking tab is folded over an outer end of said stabilizing plate when said extension plate is in said second position.

17. The mounting bracket of claim 1, wherein

said front mounting panel has a first side section, a second side section, a top section extending between said first and second side sections, and a bottom section extending between said first and second side sections, and where said first and second side sections and said top and bottom sections define said central opening;

a first side portion integrally formed with said first side section, said first side portion having said second openings formed therein and adapted for mounting to a support structure; and

where said stabilizing plate is coupled to said second side section.

18. The mounting bracket of claim 1, further comprising a bendable coupling tab for coupling said stabilizing plate and extension plate together to retain said extension plate in the extended position.

19. The mounting bracket of claim 18, wherein

said coupling tab is integrally formed with said extension member and spaced from said outer end thereof, said coupling tab being positioned to couple to said second end of said stabilizing plate.

20. The mounting bracket of claim 1, wherein said first and second openings have a keyhole shape with a dimension for a screw head for coupling the electrical outlet box to said front mounting panel.
21. The mounting bracket of claim 1, wherein said stabilizing plate includes a strengthening member to resist bending and budding.
22. The mounting bracket of claim 1, wherein said second end of said stabilizing plate has an outer edge, and said extension plate has an inner edge at said inner end coupled to said outer edge of said stabilizing plate, and said outer end of said extension plate extends toward said front mounting panel in said first retracted position.
23. The mounting bracket of claim 22, wherein said extension plate has a tab for coupling with said second end of said stabilizing plate to secure said extension plate in said second extended position.
24. The mounting bracket of claim 1, further comprising an electrical box coupled to said rear side of said front mounting panel.
25. An electrical box mounting bracket comprising:
  - a front mounting panel having a central opening with a dimension to accommodate an electrical box, a plurality of first openings for receiving screw heads for attaching the electrical box to said front mounting panel, and a plurality of second openings for fasteners for mounting said front mounting panel to a wall stud;
  - a stabilizing plate having a first end coupled to said front mounting panel and a second end to engage a first opposing wall surface spaced from a front wall a first distance during use;

an extension plate coupled to said stabilizing plate about a first fold line and being bendable from a first position to an extended second position to engage a second opposing wall surface spaced from the front wall a second distance; and

a bendable locking member integrally formed with said extension plate and oriented for coupling with said stabilizing plate to secure said extension plate in said extended position.

26. The electrical box mounting bracket of claim 25, wherein said stabilizing plate is bendable along a fold line to a position substantially perpendicular to said front mounting panel, said stabilizing plate having a strengthening member to resist bending and buckling and said extension plate has at least one fold line to shorten the length of said extension plate.
27. The electrical box mounting bracket of claim 25, wherein said stabilizing plate is formed at a right angle to said front mounting panel.
28. The electrical box mounting bracket of claim 25, wherein said extension plate is oriented substantially parallel to said front mounting panel when in said first position, and wherein said extension plate is substantially perpendicular to said front mounting plate when in said second extended position.
29. The electrical box mounting bracket of claim 28, wherein said stabilizing plate has a central opening with an inner edge, and said locking member is a tab that is foldable over said inner edge of said central opening.
30. The electrical box mounting bracket of claim 28, wherein said extension plate has a first portion integrally formed with said stabilizing plate and a second portion extending from said first portion of said extension plate, said second portion of said extension plate having an outer end

for engaging the opposing wall in the second extended position.

31. The electrical box mounting bracket of claim 25, wherein

said stabilizing plate has a central opening defining a first portion coupled to said front mounting panel and a second portion spaced from said first portion and having an inner edge, said extension plate having a first end being integrally formed with and coupled to said inner edge of said second portion of said stabilizing plate about a fold line, said extension plate being bendable from said first position extending toward said front mounting panel to said second position extending away from said front mounting panel.

32. The electrical box mounting bracket of claim 31, wherein

said second portion of said stabilizing plate has an outer edge for contacting said first opposing wall and said extension plate has a second end for contacting said second opposing wall.

33. The electrical box mounting bracket of claim 25, wherein said locking member comprises

a locking tab integrally formed with said extension plate and being bendable over an outer edge of said stabilizing plate to secure said extension plate in said second position.

34. The mounting bracket of claim 25, wherein

said first openings for attaching the electrical box are spaced around the central opening;

said front mounting panel has a first side portion on a first side of said central opening and having said second openings formed therein, and a second side portion on an opposite side of said central opening and having said stabilizing plate coupled thereto.

35. The mounting bracket of claim 34, wherein

said front mounting panel has a top section extending between said first and second side portions and a bottom section extending between said first and second side portions, said first side portion, second side portion, top section and bottom section defining said central opening.

36. The electrical box mounting bracket of claim 25, wherein said locking member is positioned to fold over an outer edge of said stabilizing plate.

37. An electrical box mounting bracket assembly comprising:

a front mounting panel having a central opening with a dimension to accommodate an electrical box, said front mounting panel having a plurality of first openings for receiving screw heads for coupling the electrical box to said front mounting plate and a plurality of second openings for fasteners for mounting said front mounting panel to a wall stud;

an electrical box coupled to said front mounting panel, said electrical box having an opening aligned with said central opening of said front mounting panel;

a stabilizing plate having a first end coupled to a side of said front mounting panel and being bendable about a fold line to an extended position wherein a second outer end of said stabilizing plate engages an opposing wall surface spaced from a front wall a first distance during use, said stabilizing plate having a central opening with a first inner edge at said first end and a second inner edge at said second outer end; and

an extension plate integrally formed with said stabilizing plate, said extension plate having a first end portion coupled to said second inner edge of said central opening of said stabilizing plate by a fold line and a second end portion spaced from said first end portion, said extension plate being bendable about said fold line between a first retracted position and a second extended position where said second end portion extends away from said front mounting plate to engage an opposing wall surface spaced from the front wall a second distance during use where said second distance is greater than said first distance.

38. The electrical box mounting bracket of claim 37, wherein  
said extension plate is foldable to said second position where said  
extension plate is substantially parallel to said stabilizing plate.

39. The electrical box mounting bracket of claim 37, wherein  
said extension plate includes a locking tab that is foldable over said outer  
end of said stabilizing plate to secure said extension plate in said extended  
position.

40. The electrical box mounting bracket of claim 37, wherein  
said extension plate defines a cut portion from said stabilizing plate to  
form said central opening.

41. The electrical box mounting bracket of claim 37, wherein  
said extension plate includes at least one fold line adapted to shorten a  
length of said extension plate.

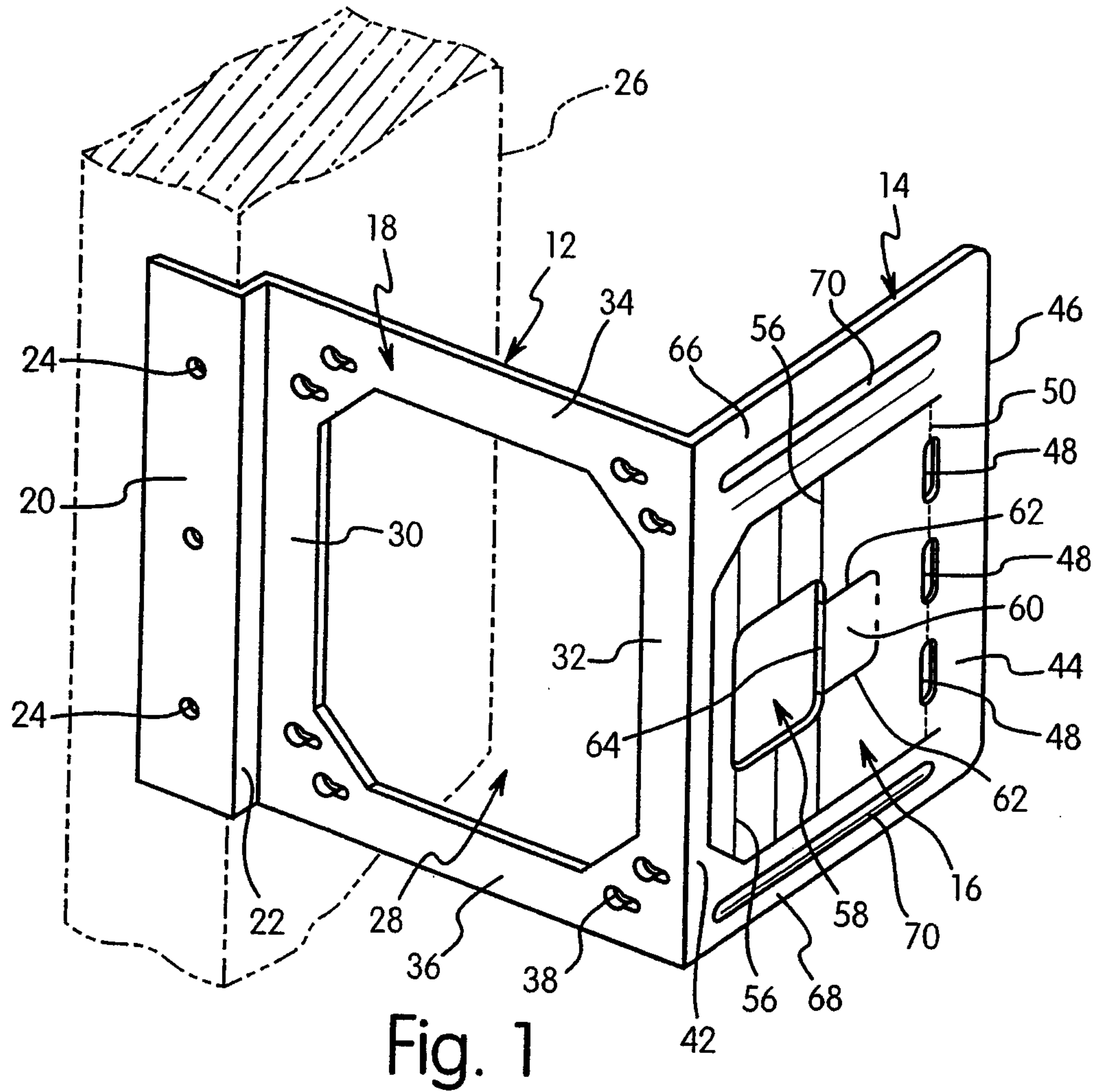

Fig. 1

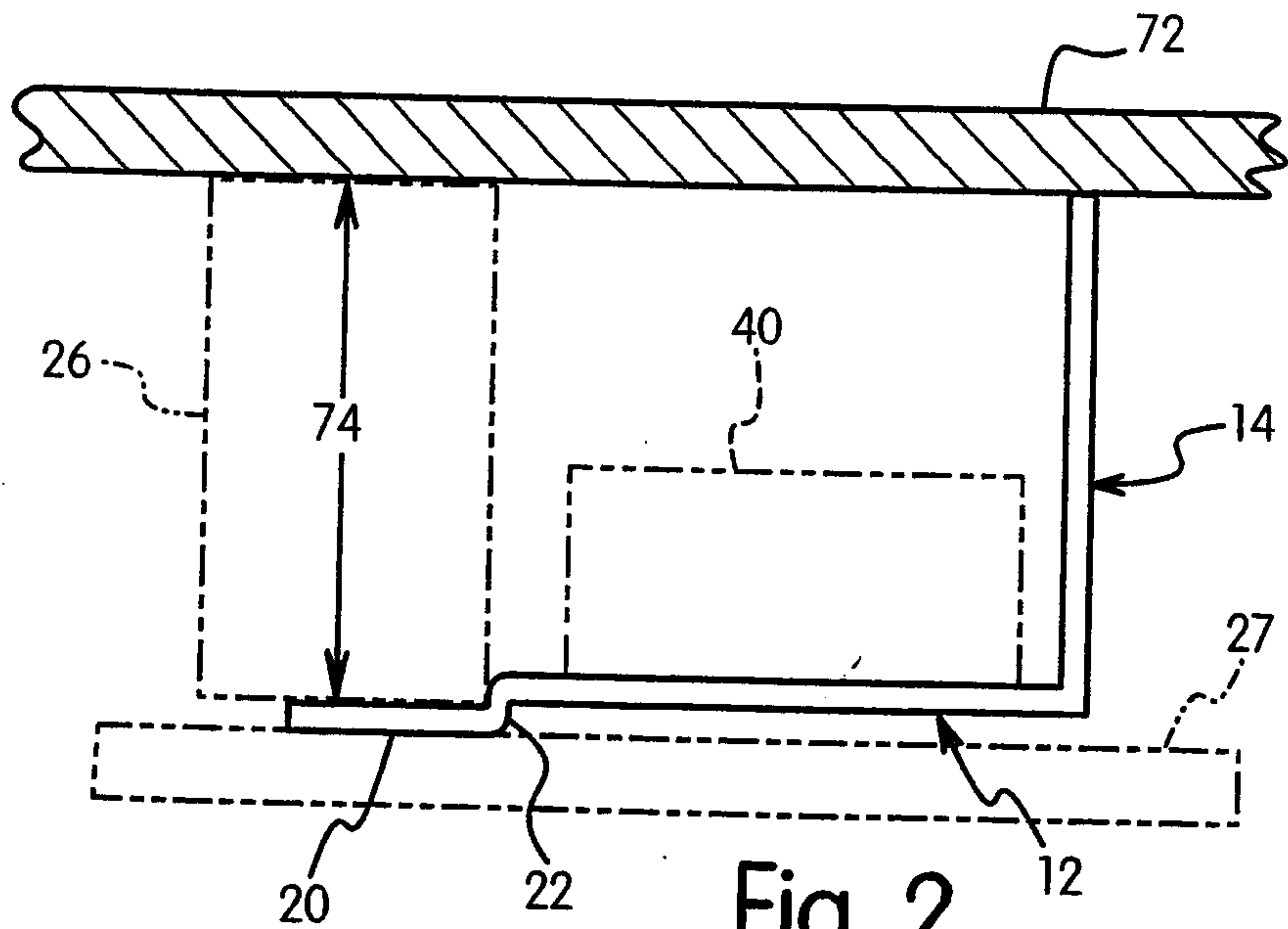
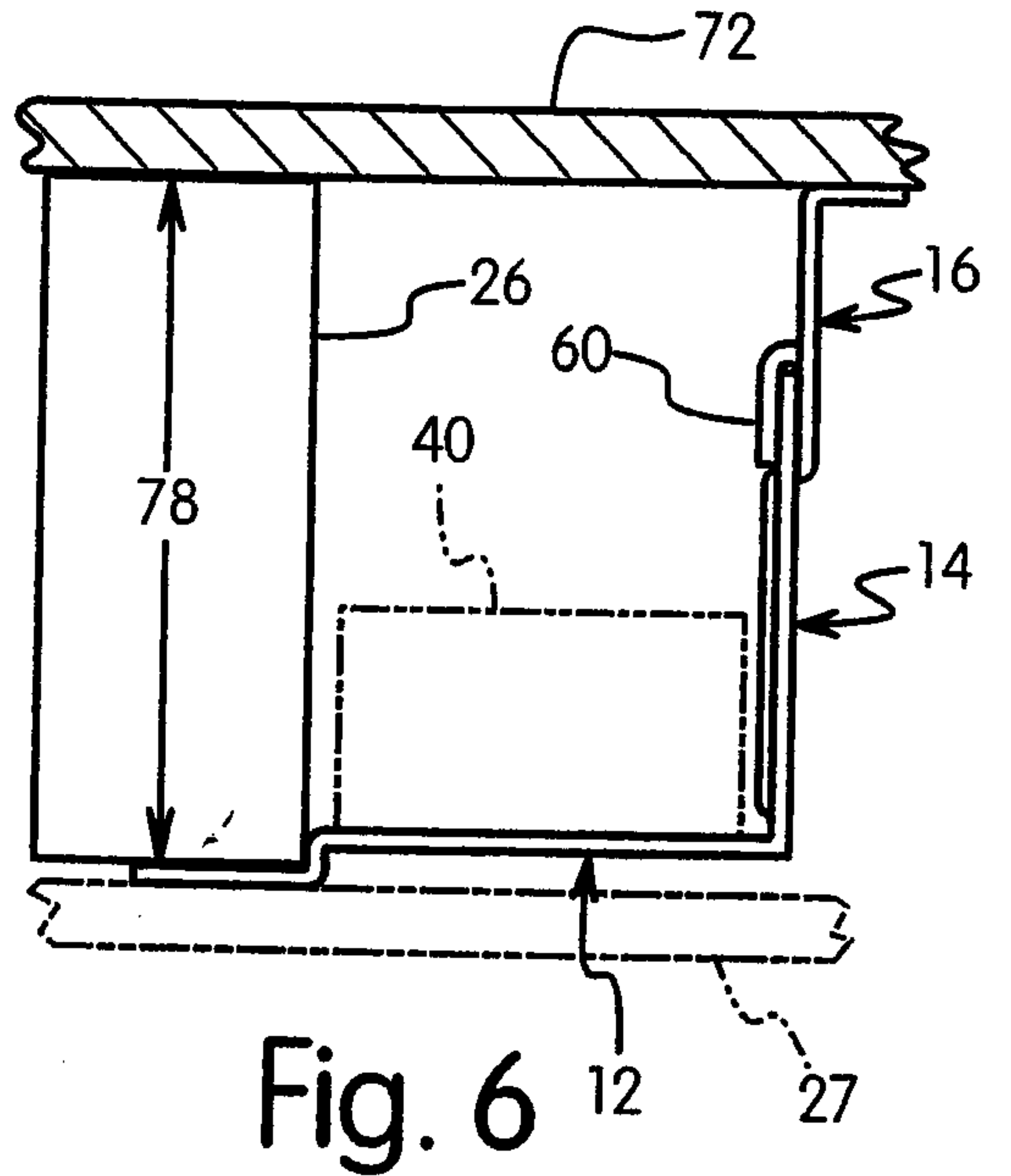
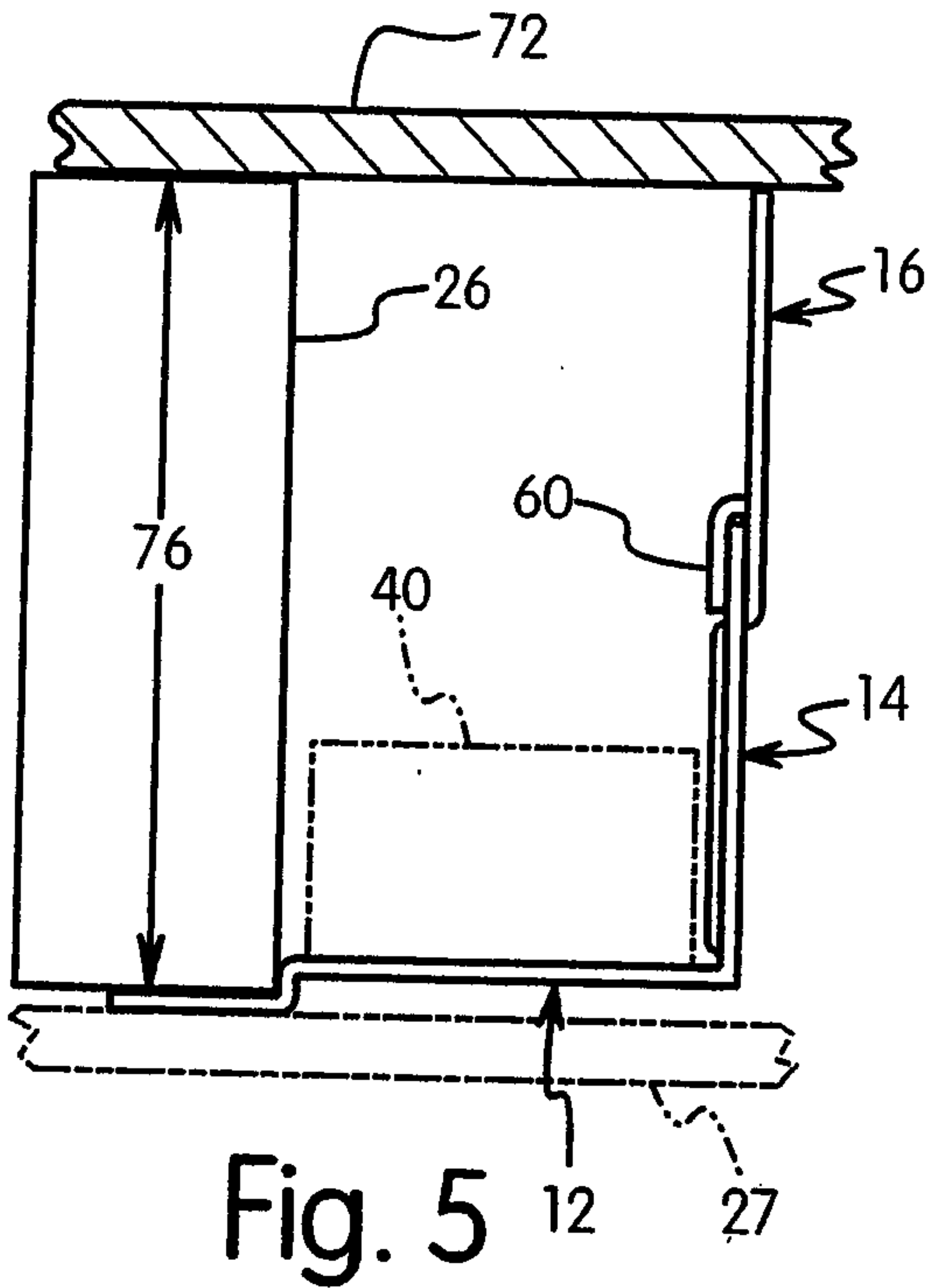
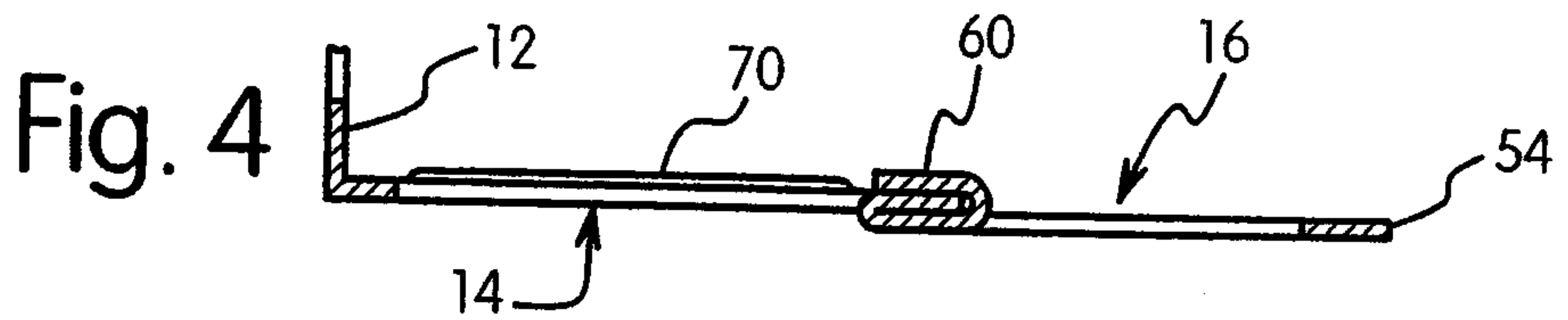
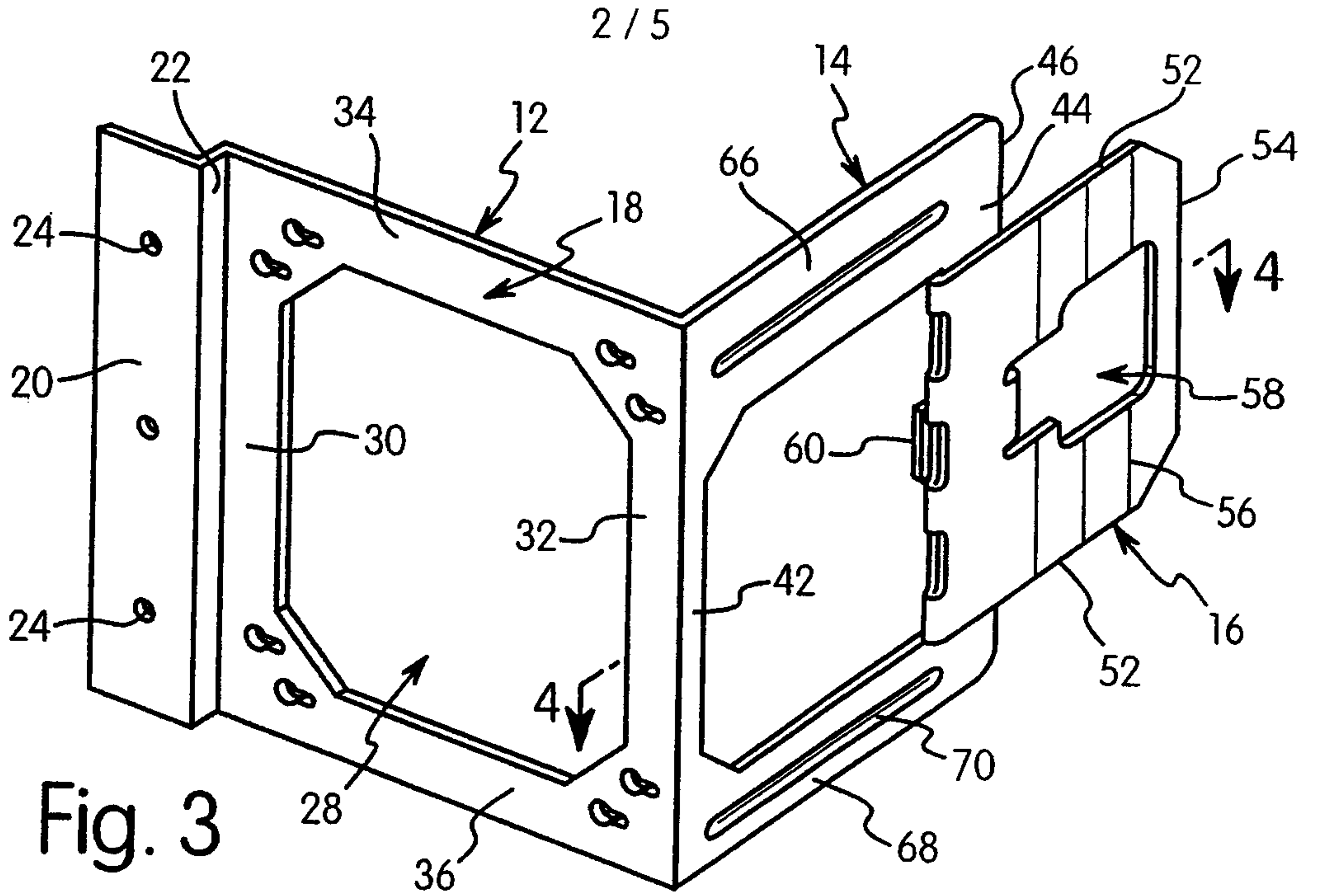

Fig. 2

*Zulayda & Singletary*  
PATENT AGENTS



*Julayan & Singletary*  
PATENT AGENTS

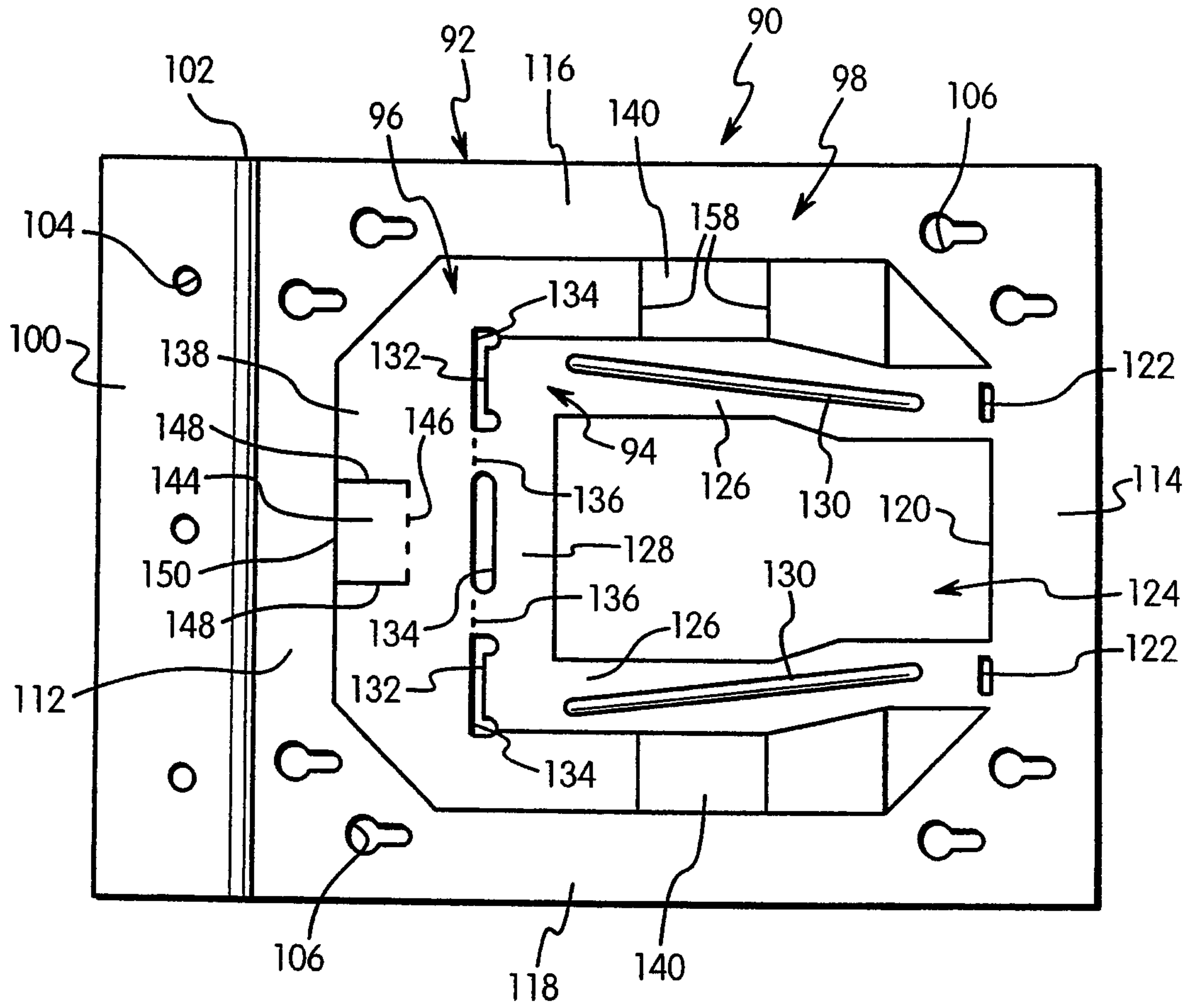

Fig. 7

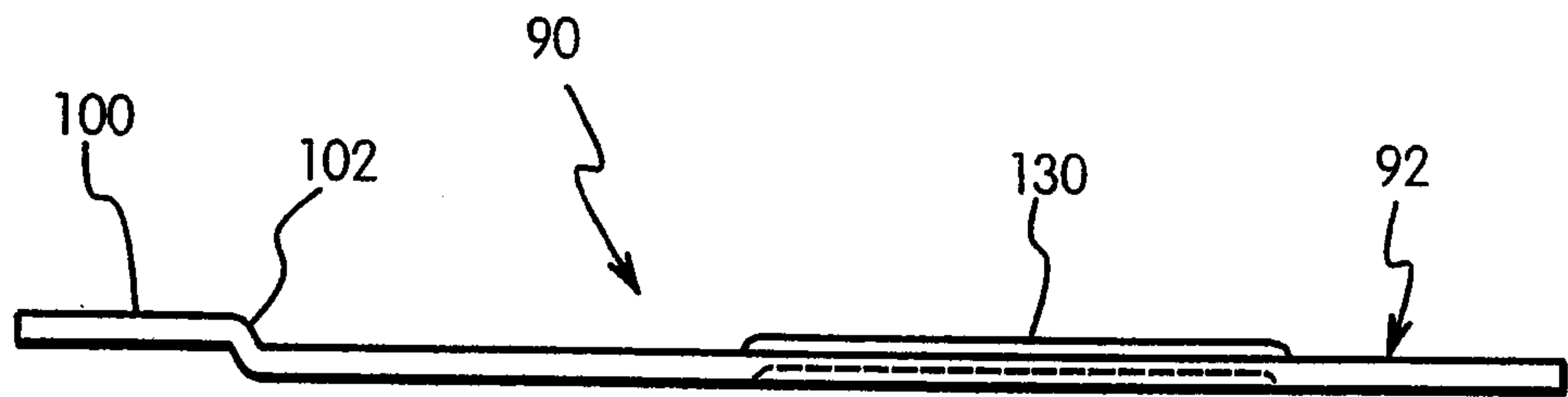

Fig. 8

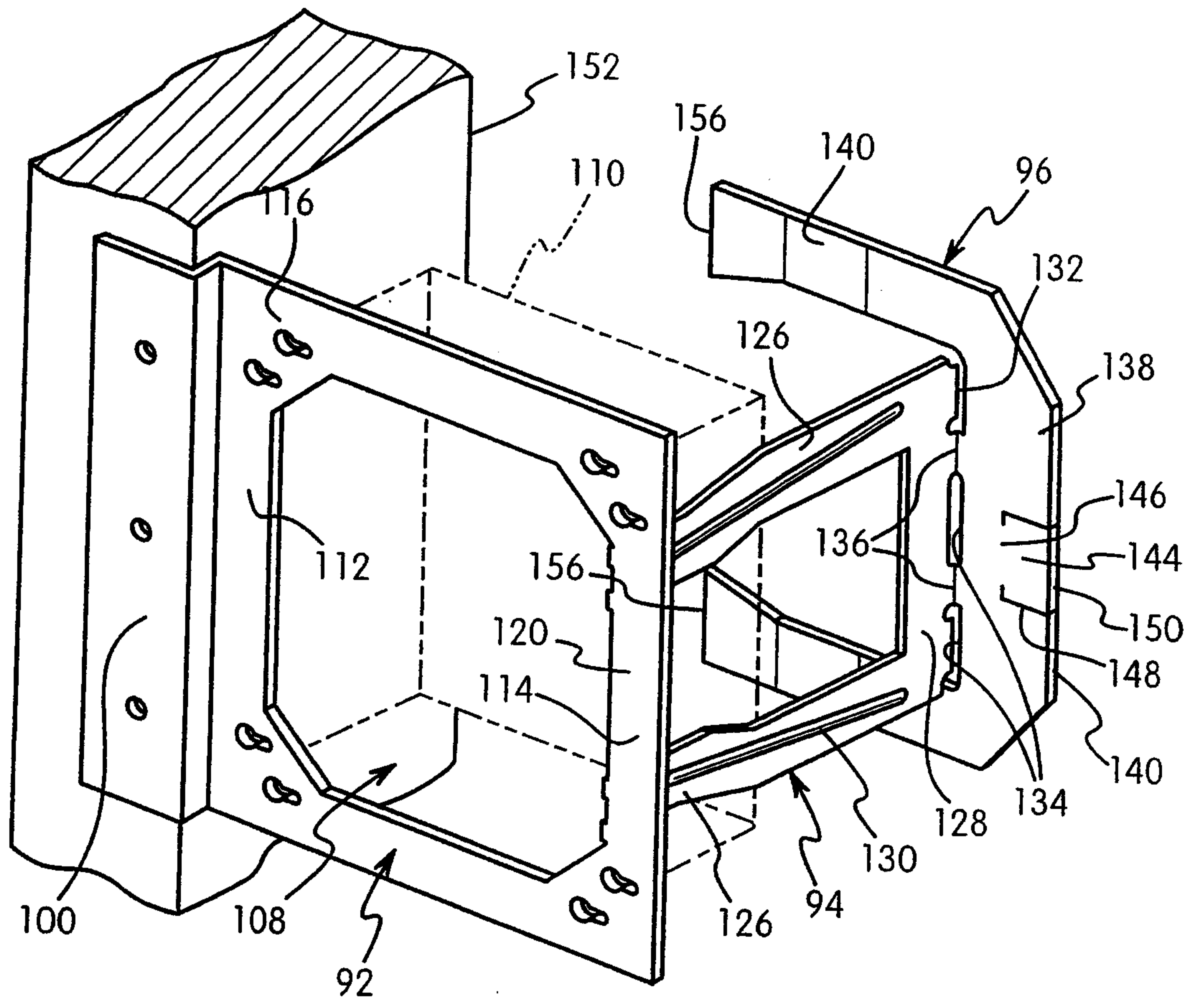

Fig. 9

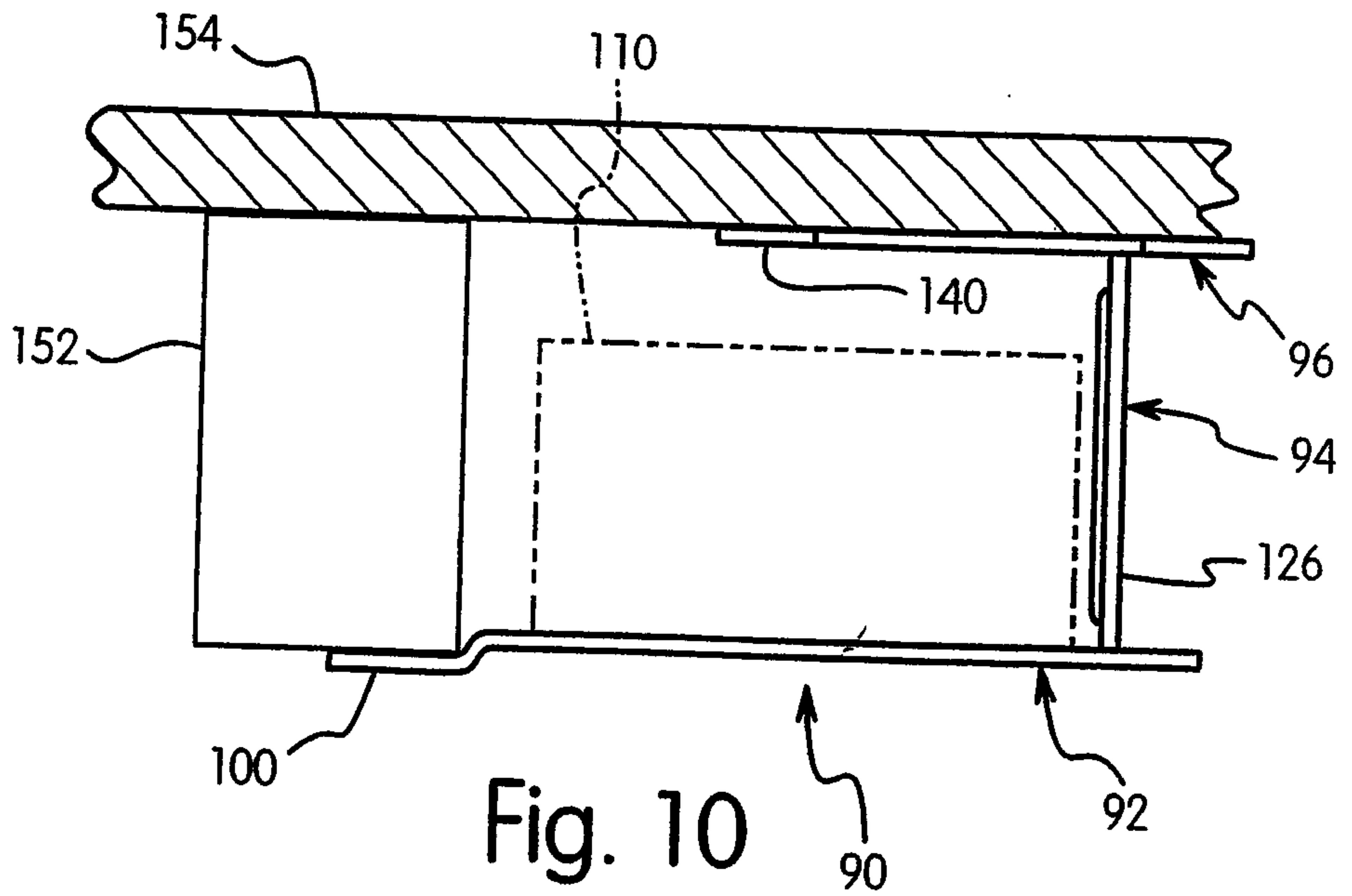

Fig. 10

*Zulayna W. Ingelust*

PATENT AGENTS

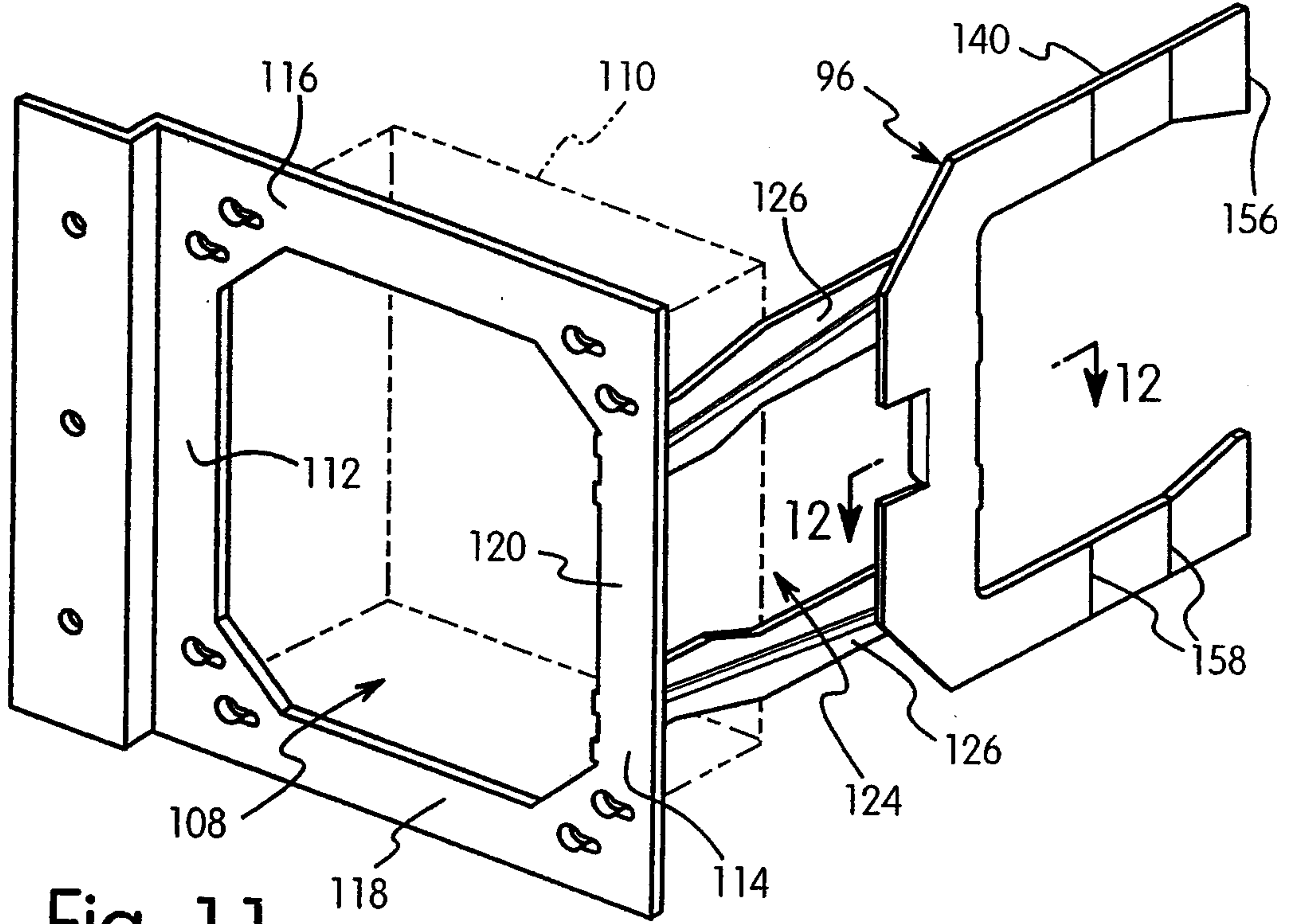

Fig. 11

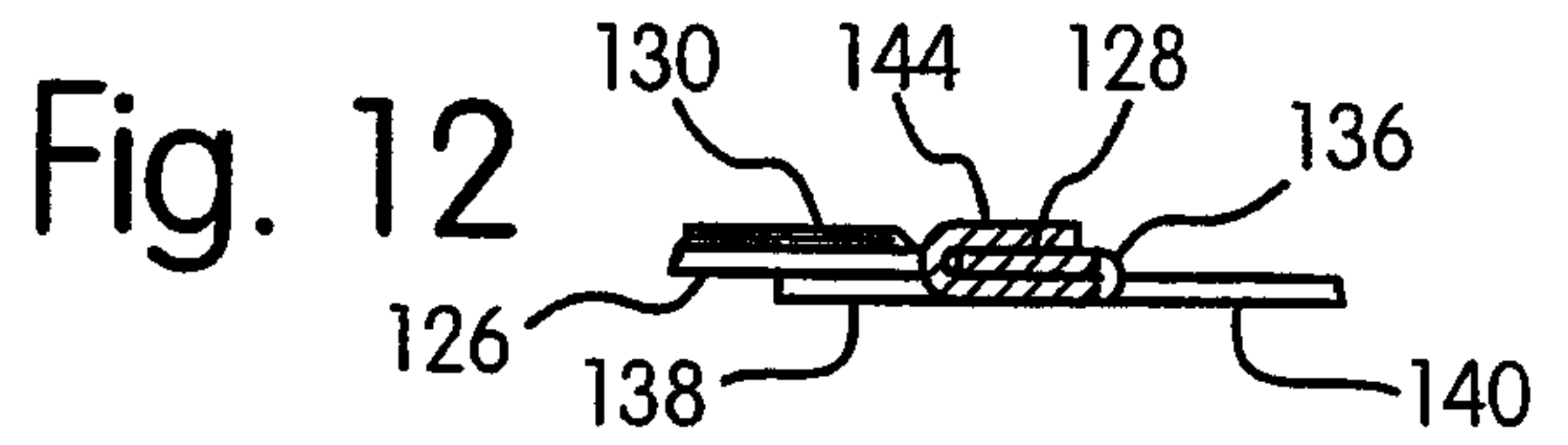

Fig. 12

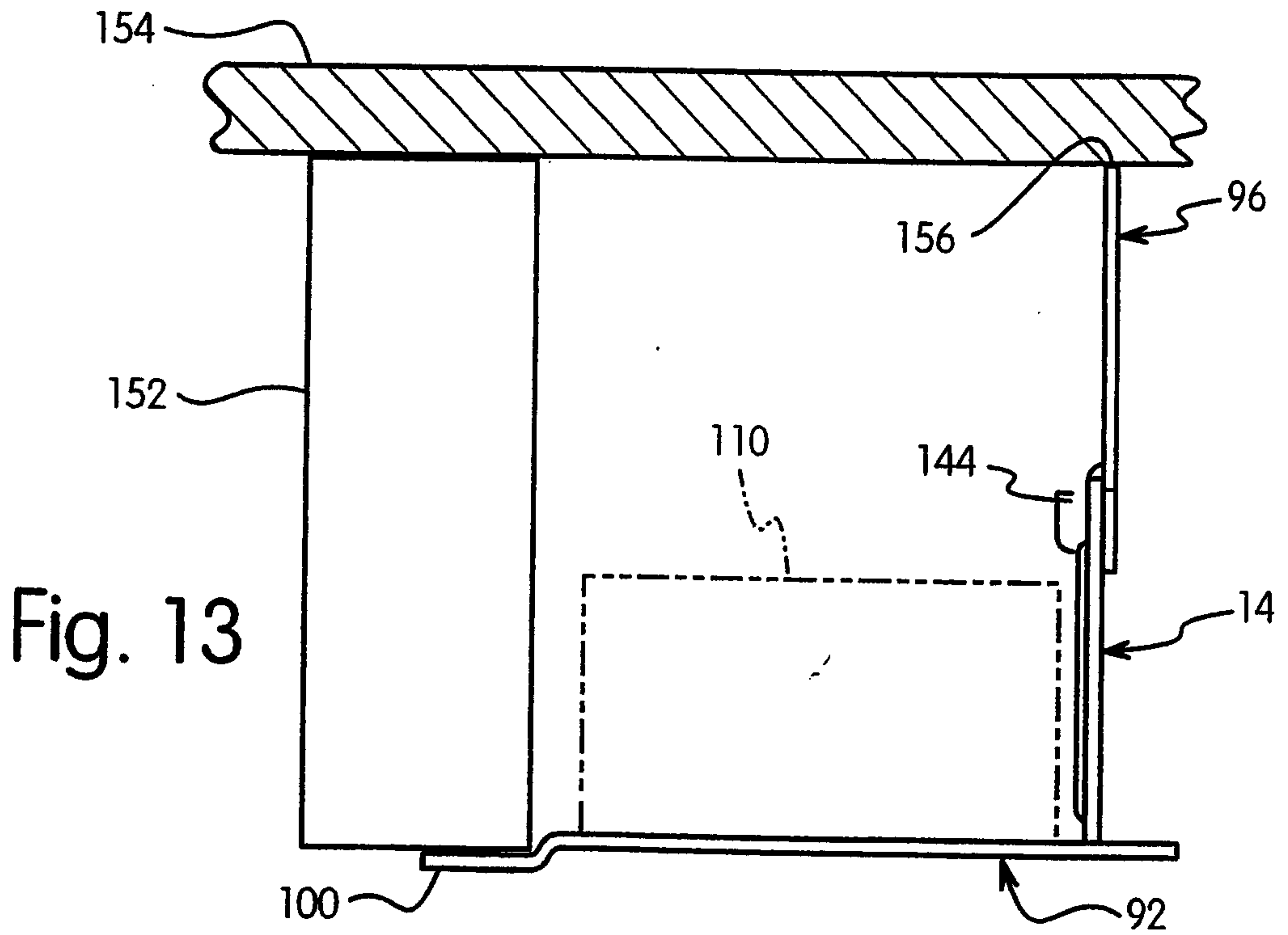

Fig. 13

