

(No Model.)

2 Sheets—Sheet 1.

W. F. CLASS.

VENT PLUG FOR KEGS AND CASKS.

No. 376,635.

Patented Jan. 17, 1888.

Fig. 1.

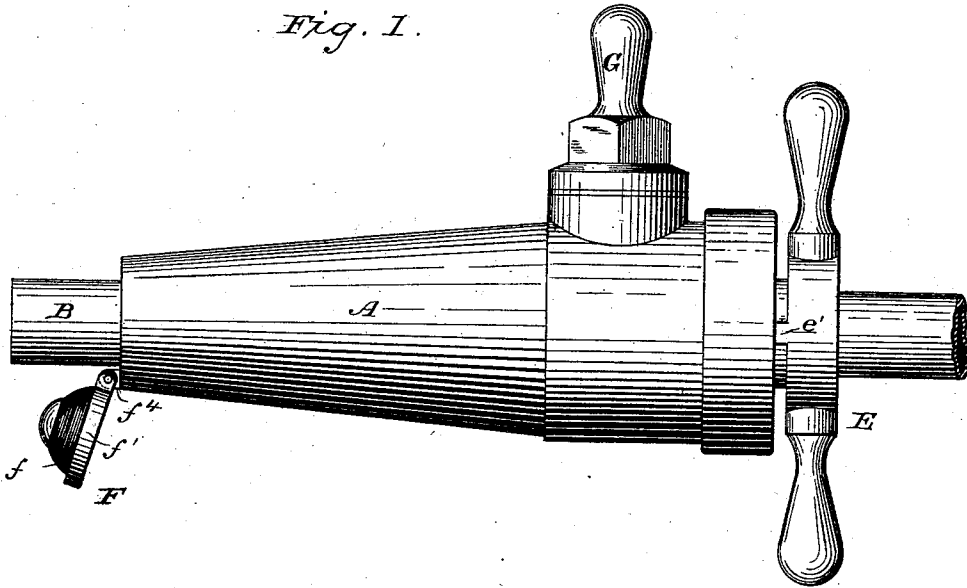
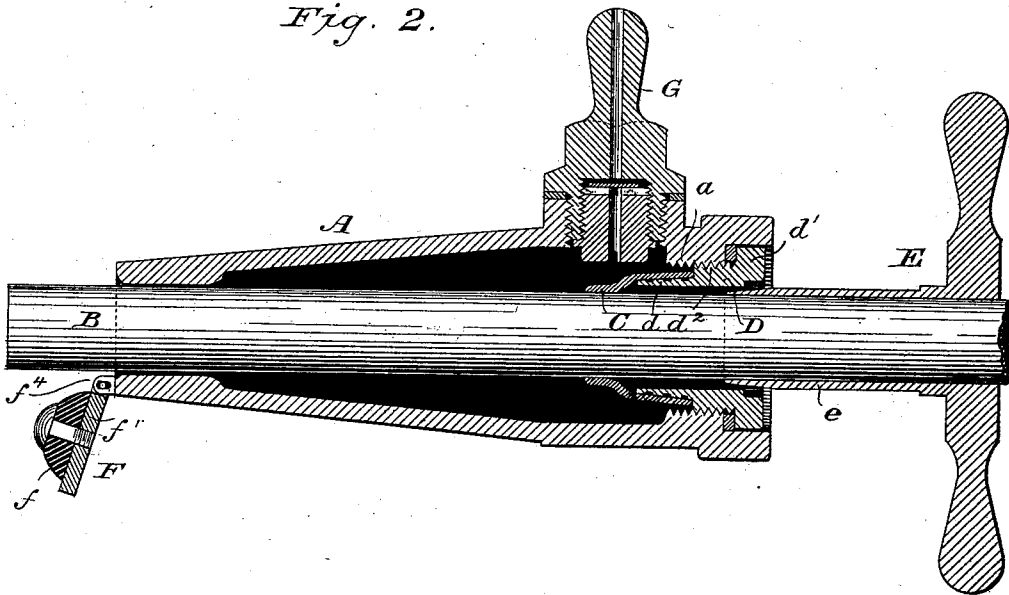

Fig. 2.



Witnesses

Wm. A. Skinkley.
Arthur Johnson.

Inventor

William F. Class

By his Attorney

Chas. G. Page

(No Model.)

2 Sheets—Sheet 2.

W. F. CLASS.

VENT PLUG FOR KEGS AND CASKS.

No. 376,635.

Patented Jan. 17, 1888.

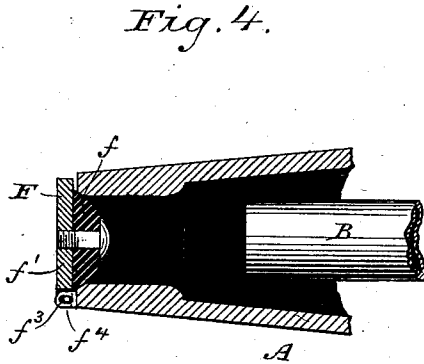

Fig. 3.

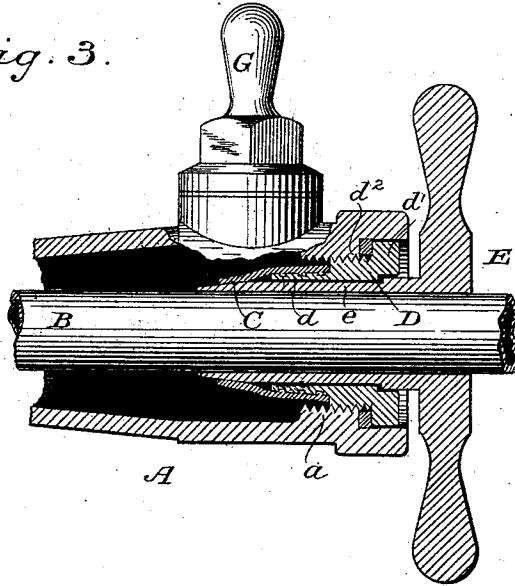

Fig. 6.

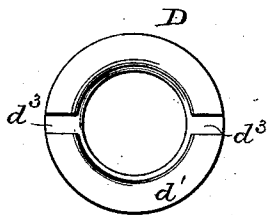

Fig. 5.

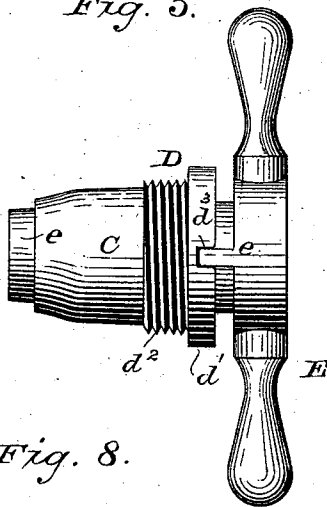

Fig. 7.

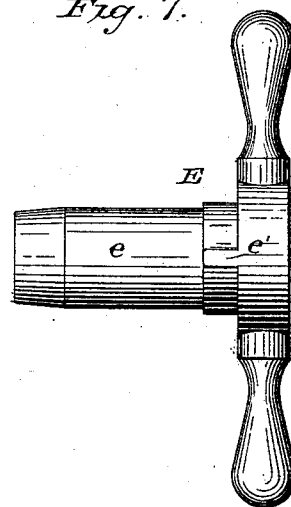
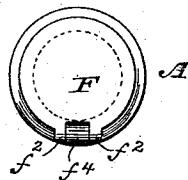

Fig. 8.



Witnesses

Wm. A. Siskel.
Arthur Johnson.

Inventor
 William F. Class

By his Attorney, Chas. G. Page

UNITED STATES PATENT OFFICE.

WILLIAM F. CLASS, OF CHICAGO, ILLINOIS, ASSIGNOR TO FRED F. TEMPLE
AND WILLIE A. JOHNSON, OF SAME PLACE.

VENT-PLUG FOR KEGS AND CASKS.

SPECIFICATION forming part of Letters Patent No. 376,635, dated January 17, 1888.

Application filed April 21, 1887. Serial No. 233,586. (No model.)

To all whom it may concern:

Be it known that I, WILLIAM F. CLASS, a citizen of the United States, residing in Chicago, in the county of Cook and State of Illinois, have invented certain new and useful Improvements in Vent-Bungs for Kegs or Casks, of which the following is a specification.

This invention relates to an improvement in vent bungs or plugs employed for tapping kegs or casks, and involving the feature of a hollow externally-tapered plug or bung, designed to be driven into the bung-hole of a keg or cask, and provided with a laterally-arranged air-inlet and with a discharge or eduction-tube extending axially through the hollow plug, the eduction-tube being of a diameter to leave between the tube and the plug an annular passage which is uninterrupted from the inner end of the plug that enters the keg or cask to the lateral inlet-passage, but which between said lateral inlet-passage and the outer end of the plug is closed by a packing disposed within the plug and adapted to fit around the discharge or eduction tube.

An object of my invention is to provide means for efficiently holding within the plug a tubular packing which for a portion of its length embraces the eduction-tube when the latter is extended through the plug, and to permit the releasement of the grip of the tubular packing upon the eduction-tube without removing such packing from the plug at such times as it may be desired to withdraw the eduction-tube.

Letters Patent No. 220,931, heretofore granted me, may be referred to as illustrating a vent-plug wherein a removal of the packing from the plug, along with a withdrawal of the eduction-tube from the plug, is necessary. In said patent the eduction-tube passes through and fits the bore of a hollow stopper which closes the plug at its butt-end, and which comprises a short tube thrust to some extent into a packing-tube, which latter for the portion of its length that is stretched upon said short tube provides the stopper with a bearing-surface that is to be forced into a straight cylindrical portion of the bore of the plug. Said length of the packing-tube that is thus stretched upon the short tube is clamped laterally between the smooth cylindrical inner wall

of the plug and short tube whereon it is stretched, and hence the retention of the stopper within the plug is dependent solely upon the force with which it is crowded into a straight cylindrical passage. I have also found by experience that after the free end portion of the tubular packing has for a comparatively short time been permitted to clasp the eduction-tube its adherence thereto will become so great as to render it impracticable to pull out the eduction-tube and leave such packing still within the plug. These difficulties I have overcome by my present invention, as will be hereinafter set forth.

A further object of my invention is to provide the plug with a hinged stopper, which, while hinged to the driving end of the plug, can be readily and accurately driven to a suitable extent into the bore of the plug without breaking the hinge-joint.

To the attainment of the foregoing and other useful ends my invention consists in matters hereinafter described, and particularly pointed out in the claims.

In carrying out my invention the hollow plug is adapted at what may be termed its "outer" end to be struck with a mallet or the like, and is further adapted at said end to receive a hollow packing-support, which at one end is threaded to screw into the plug, and at its opposite inner end provided with a tubular stem or neck, whereon is stretched and fitted a portion of the length of an elastic tube smaller in diameter than the diameter of the tubular stem or neck, whereby the free end portion of the elastic tube will constitute a tubular packing contracted considerably smaller than the neck, so as to close upon and tightly embrace the eduction-tube that will be inserted through the hollow packing-support after the keg or cask has been tapped. The hollow packing-support also constitutes a tubular guide or sleeve, through which the tubular stem of a key applied to slide on the eduction-tube can be introduced for the purpose of expanding the tubular packing and relieving the same from its hold upon the eduction-tube, in order that the eduction-tube can be freely drawn through the tubular key, and thereby removed from the vent-plug. This tubular key also serves

as a key or wrench for unscrewing the hollow packing-support from the plug; and, further, as a means for centering the eduction-tube within the plug at such time as the key is applied within the hollow packing support, but not introduced to an extent to expand the tubular packing.

The smaller driving end of the hollow tapered plug is temporarily closed and tipped by a stopper, which, while closing the plug, also serves as its driving terminal. Said combined stopper and driving terminal is permanently hinged upon the smaller end of the plug, and consists of a substantially spherical elastic body secured to a metal back plate. The diameter of this elastic body is greater than the diameter of the bore of the plug; but under compression such elastic body fits tightly within the bore of the plug, and by reason of its expansive tendency while thus under compression it serves as the sole means for holding the hinged stopper closed and in position to tip the plug—that is to say, to keep the metal back for such elastic body square up against the end of the body of the plug. No further means are herein necessary or provided for holding the stopper closed, and hence I am enabled to dispense with the use of such externally-arranged metal springs as have been used in connection with flap-valves heretofore proposed in conjunction with bushings for kegs or casks. The driving end of the plug herein involved has no external projections or obstructions which can strike against the wall of the bung-hole into which the plug is to be driven during the act of knocking in the bung in tapping, and hence the combined hinged stopper and driving terminal is in no wise liable to be injured either in tapping or in withdrawing the plug from the keg or cask.

As a further feature of improvement in this direction the component members of the hinge-joint respectively attached to the stopper and the plug have a limited play independently of one another in a direction coincident with the longitudinal axis of the plug, so that after the elastic body of the stopper has been inserted in the bore of the plug the stopper as a whole will, upon being struck a sharp blow, move in a direction coincident with the axis of the plug, thus permitting it to close properly and fit the bore accurately.

In the drawings, Figure 1 represents in side elevation a vent-plug provided with my improvements. Fig. 2 represents a central longitudinal section through the same with the eduction-tube in elevation. Fig. 3 is a longitudinal central section through the outer end portion of the vent-plug with the key pushed in to an extent to free the tubular packing from contact with the eduction-tube. Fig. 4 is a like view of the inner end of the vent-plug with the hinged stopper closed. Fig. 5 is a detail representing in elevation the hollow packing-support provided with the tubular packing

and the key fitted to pass through both the hollow packing-support and the free end portion of the tubular packing. Fig. 6 is a front end view of the hollow packing-support. Fig. 7 represents the key. Fig. 8 is an end view of the vent-plug, showing the inner end thereof closed by the hinged stopper.

The hollow plug A is suitably tapered toward one end, in order to permit it to be driven into the bung-hole of the keg or cask that is to be tapped. The opposite butt-end of the plug, which stands outside the keg or cask when the plug is driven therein, is adapted to receive the blows of a mallet or like implement used in tapping.

At a suitable point along its length the plug is provided with a valved lateral inlet-passage for the admission of air to supply the place of the liquid drawn off from the cask and to maintain the desired pressure within the same.

The eduction-tube B is made somewhat smaller than the bore of the plug, so as to provide an air-passage from the lateral inlet to the inner end of the plug, it being understood that said tube is to be provided with or connected by suitable tubing to a cock for drawing off the liquid after the keg or cask has been tapped and the tube inserted through the plug.

The annular space or passage between the eduction-tube and the wall of the bore through the plug is closed at a point between the lateral inlet and the outer end of the plug by the packing C, consisting of a short length of flexible or elastic tubing, which is applied to a hollow packing-support, D. This hollow packing-support is formed with a cylindrical bore, and is externally adapted to provide a tubular stem or neck, d , constituting its inner end portion, the remaining outer end portion of the hollow packing-support being externally adapted to provide an annular flange, d' , with an externally-threaded portion, d'' , between said flange and a shoulder that is formed at the junction of the threaded portion with the neck d .

The elastic tubular packing is made somewhat longer than the neck d , but of less diameter than the same, and is for a portion of its length drawn upon the neck, and thereby expanded in diameter along such portion as is thus drawn upon the neck of the hollow packing-support. The free end portion of the tubular packing—that is to say, the portion which is not drawn upon the neck—remains unexpanded, and, in fact, will be somewhat contracted by reason of the expansion of its remaining portion.

The plug is internally threaded, as at a , to engage the threaded portion of the hollow packing-support, and at its outer end is provided with an enlargement of its bore, so as to form an annular seat for the reception of the annular flange at the outer end of the hollow packing-support, and to further permit the latter to set back within the plug to an extent to avoid damage to the packing-support when the plug is struck in tapping.

The hollow packing-support thus provided with the tubular packing can be left continuously within the plug, although should it at any time be desired to remove the same it can be readily unscrewed and taken out.

The feature of threading the hollow packing-support along a portion of its length so as to afford for such threaded portion a bearing directly in the plug serves to positively hold the hollow packing-support as against pressure from the keg or cask. The provision of the stem or neck *d* beyond or back of the point where the hollow packing-support has its bearing in the plug is also a more desirable way of retaining the elastic tube within the plug, particularly since the stretching to the elastic tube to fit it on a tube or collar, as in my patent hereinbefore referred to, would be apt to bring the stretched portion in such condition that its service as an elastic stopper would prove a failure.

After the plug has been driven into a keg or cask, the eduction-tube can be inserted through the plug, and in so doing it will pass through the elastic tubular packing. The normal diameter of the packing should be somewhat less than that of the eduction-tube, whereby after the latter has been pushed through the tubular packing the latter will tightly embrace the eduction-tube to an extent proportional to the length of the free end portion of the tubular packing, as represented in Fig. 2.

When the tubular packing is properly applied, it will be difficult to withdraw the eduction-tube from the outer end of the plug, since the greater the force the more the packing will bend upon the eduction-tube, and should the eduction-tube be withdrawn by using great force injury to the tubular packing would be apt to occur. As a means for temporarily relieving the eduction-tube from the grip of the tubular packing thereon, I provide a hollow key, E, adapted to fit and slide upon the eduction-tube and formed with a tubular stem, *e*, which, when the key is applied, can be slipped along the eduction-tube from its position shown in Fig. 2 to the position shown in Fig. 3, so as to pass between the tubular packing and the eduction-tube, thereby expanding the free end portion of the tubular packing and holding the same off from the eduction-tube.

It will be observed that the bore of the hollow packing support is made somewhat larger than the eduction-tube in order to provide working space for the tubular stem of the key, and that the said stem is somewhat tapered toward one end, so that it can be readily wedged between the free end portion of the tubular packing and the eduction-tube.

The key can be applied before the insertion of the eduction-tube, but at such time need not be pushed far enough into the keg to enter the free end portion of the tubular packing, it being observed that it will be pushed in considerably farther than in Fig. 2, wherein the key is shown as extended to a considerable

extent out from the hollow packing-carrier for convenience of illustration. The key E, when fitted in the hollow packing-support to a proper extent, also affords a bearing of suitable length for centering and steadying the eduction-tube, it being obvious that while the latter can be made to fit within the key for such purpose the eduction-tube can, nevertheless, be drawn out from the key after the latter has been pushed in to an extent to free the tubular packing from its grip upon the eduction-tube.

The key E may be, and as herein shown is, adapted to serve as a convenient means for turning the hollow packing-support so as to either screw the same into or unscrew it from the plug. To such end the key is provided with one or more, preferably with a couple, of lugs or short longitudinal ribs or keys, *e'*, which, when the key is pushed well into the hollow packing-support, engage in notches *e''* in the outer flanged end of the latter. After the key has been thus brought into engagement with the hollow packing-support the key can be operated so as to turn and either adjust the hollow packing-support within the plug or remove the same, as may be desired. The key is also desirably provided with one or more handles, so that it can be conveniently operated.

The stopper F, which is permanently hinged to the inner end of the plug, is provided with a hemispherical or analogous-shaped elastic cushion or body portion, *f*, secured to a hinged metal back plate, *f'*. When the stopper is closed, its elastic body portion *f* will be forced into the terminal of the bore through the plug, as in Fig. 4, it being only necessary to bring the stopper to a nearly-closed position and to then strike the stopper, so as to force its elastic body portion into the bore of the plug, after which the elastic force of the compressed body portion of the stopper will hold the stopper closed as long as may be necessary. It may be observed that to thus close the stopper the plug can be conveniently taken in one hand, with its closed inner end down, and then struck down upon a keg or other convenient article.

When the hinged stopper is brought by hand into position so that its elastic body portion shall register with and enter to some extent the base of the plug, a sharp blow on the stopper will force and wedge the elastic body portion into the plug. The elastic force of the stopper thus compressed in the plug will serve to hold the stopper tightly closed and will obviate the necessity for an auxiliary spring, it being observed that were a spring provided upon the plug it would be liable to become broken off in tapping.

In order to permit the elastic body portion of the hinged stopper to accurately fit the plug, the hinge-joint between the stopper and the plug is formed to have between its component parts, that are respectively attached to the stopper and the plug, a limited extent of play

in a direction coincident with the axis of the plug. To such end the pintle whereby the stopper is hinged is secured at its ends in lugs f^2 on the cap or back plate of the stopper, and between such lugs passes through an eye or opening, f^3 , that is formed through a lug, f^4 , on the plug, and made oblong in cross section, as shown in Fig. 2. This permits the pintle to have a certain extent of lateral play independent of the plug, so that after the stopper has been turned up in front of the end of the plug it will when struck for closing purposes be permitted to move in a direction coincident with the axis of the plug, thereby causing it to fit the plug tight and true. The stopper will of course be closed preparatory to tapping. After tapping, the eduction-tube can be inserted through the hollow packing-support and tubular packing or packing-tube and forced against the stopper, so as to open the same. The stopper when closed practically forms the terminal of the driving end of the tapered plug, and so long as its elastic body portion f is wedged in the bore of the plug the stopper may be regarded as solid with and a part of the plug, thereby in no wise interfering with the free driving of the plug into the bung-hole of a keg or cask.

As hereinbefore observed, the stopper F will be closed preparatory to tapping. When thus closed, the elastic body portion f of the stopper will fit within the bore of the plug, while the stout metal back f' of the stopper will set up against the end of the plug, as in Fig. 4, where in the slight space shown between the metal back f' and the end of the plug is merely for convenience of illustration. The annular perimeter of the back plate, f'' , of the stopper is substantially flush with or slightly within the cylindrical circumference of the driving end of the plug A , whereby there is no obstruction to tapping about the driving end of the plug, which, when ready for tapping, is, in effect, simply tipped by an end plate, which consists of the metal back f'' of the stopper. The solidity and strength of this stopper avoids breakage and injury incident to the liberal blows and pounding bestowed upon plugs in tapping kegs and casks, and since no springs are employed for closing the stopper the plug can when its stopper is closed be freely driven into a keg without injury to the stopper. After the plug has been driven into the keg so as to knock in the bung and take a firm hold in the

bung-hole the eduction-tube will be pushed in, so as to force open the stopper F , which will then hang, as in Fig. 2. The beer or the like is drawn off through the eduction-tube, which will, as usual, have or be connected at its outer end with a faucet, all of the contents of the keg being thus drawn off. After the contents of the keg have become exhausted the eduction-tube can be either withdrawn entirely from the plug or drawn back, as in Fig. 4, whereby in drawing out the plug A the hinged stopper F can in passing the rim of the bung-hole swing up to the end of the plug, so as to permit its withdrawal from the keg. After this the stopper will be placed by hand in a nearly-closed condition—that is to say, placed with its elastic body portion f in register with the bore of the plug—whereupon a sharp blow on the stopper will wedge its said elastic body portion in the plug.

What I claim as my invention is—

1. In a vent-plug through which an eduction-tube is introduced for the purpose set forth, the packing-tube held for a portion of its length upon a hollow packing-support, in combination with a hollow key having a tubular stem adapted to enter the hollow packing-support and having its bore adapted to receive the eduction-tube, the bore of the hollow packing-support being somewhat longer than the eduction-tube, so as to permit the tubular stem of the key to enter the space between the hollow packing-support and the eduction-tube and to pass between the portion of the packing-tube that is contracted upon the eduction-tube, in order to separate the packing-tube from the eduction-tube, substantially in the manner and for the purpose set forth.

2. The hollow vent-plug provided at its driving end with a hinged stopper, F , having an elastic body portion of normally greater diameter than the bore of the plug, and attached to the plug by a hinge-joint having between its component connected parts a limited extent of play in a direction parallel with the longitudinal axis of the plug, whereby in driving the elastic body portion into the plug the hinged stopper can move bodily in a direction coincident with the axis of the plug, substantially as and for the purpose set forth.

WILLIAM F. CLASS.

Witnesses:

CILAS. G. PAGE,
L. S. LOGAN.