

J. TODD.
REVERSIBLE CURRENT APPARATUS FOR CONDENSERS.

APPLICATION FILED MAR. 14, 1904.

2 SHEETS—SHEET 1.

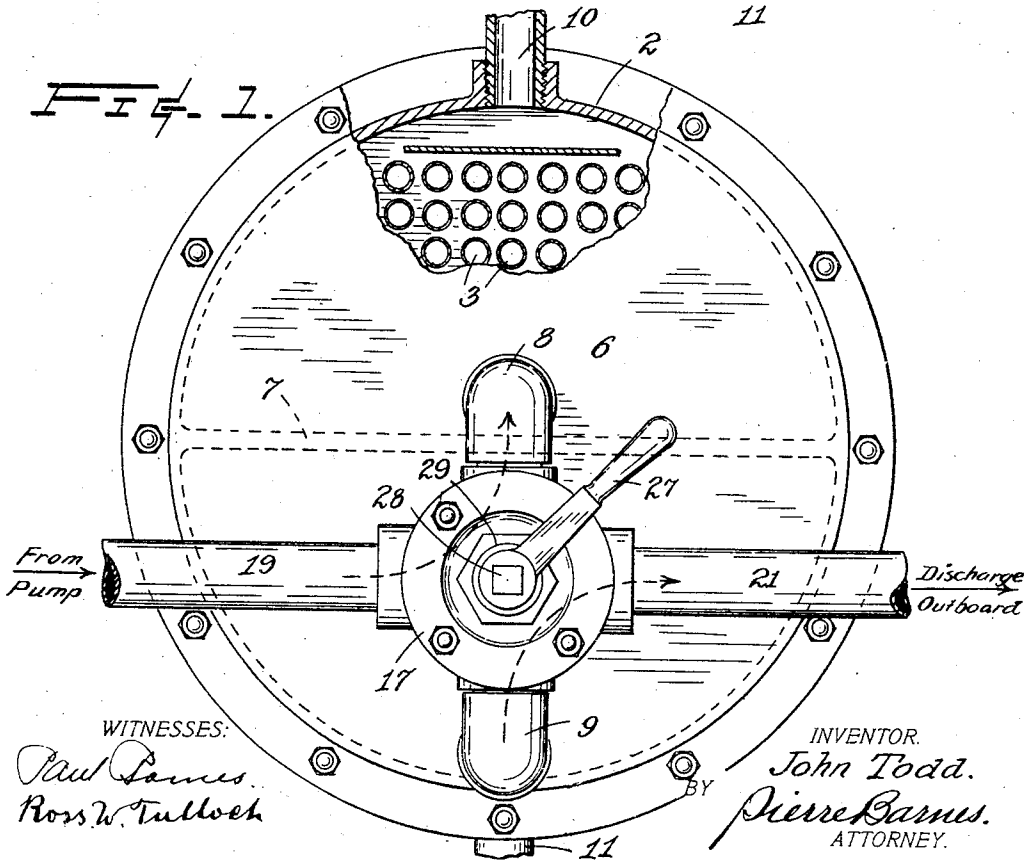
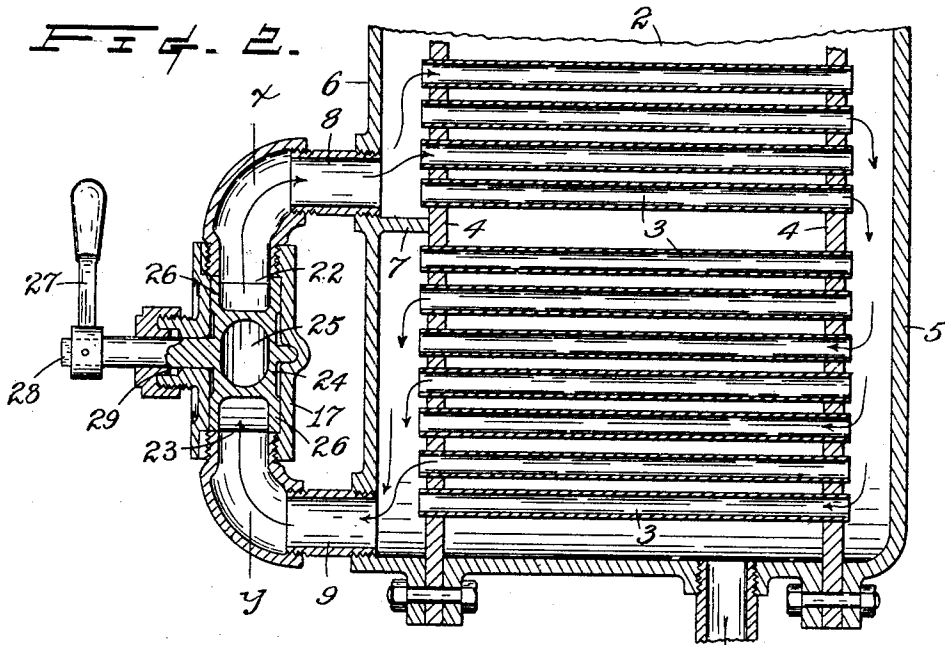

WITNESSES:
Paul James
Ross W. Tulloch

INVENTOR.
John Todd.
 BY *Pierre Barnes.*
 ATTORNEY.

J. TODD
REVERSIBLE CURRENT APPARATUS FOR CONDENSERS.

APPLICATION FILED MAR. 14, 1904.

2 SHEETS—SHEET 2.

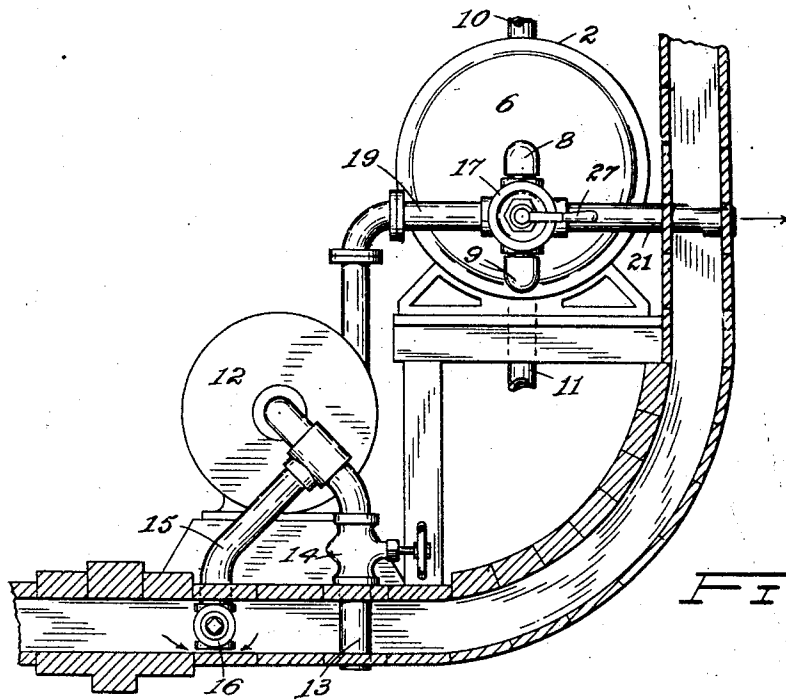

FIG. 4.

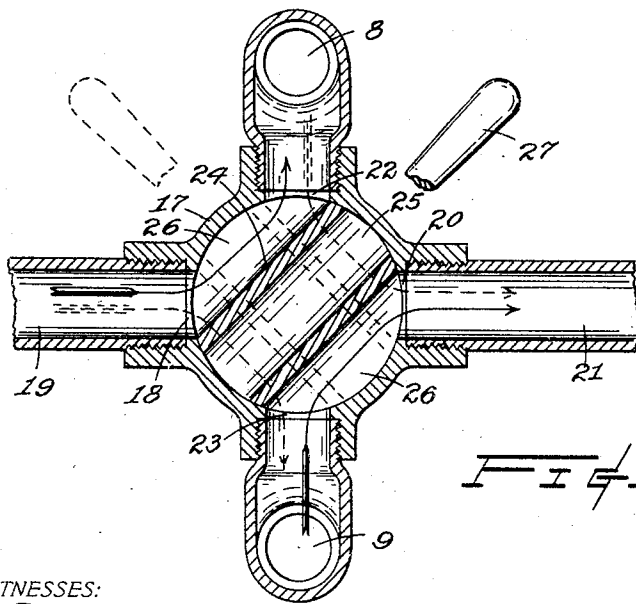

FIG. 3.

WITNESSES:

Paul Barnes,
Ross W. Tulloch

INVENTOR.

John Todd.
BY *Pierre Barnes*
ATTORNEY.

UNITED STATES PATENT OFFICE.

JOHN TODD, OF SEATTLE, WASHINGTON, ASSIGNOR OF ONE-HALF TO
GEORGE WINFIELD WILSON, OF SEATTLE, WASHINGTON.

REVERSIBLE-CURRENT APPARATUS FOR CONDENSERS.

SPECIFICATION forming part of Letters Patent No. 779,889, dated January 10, 1905.

Application filed March 14, 1904. Serial No: 198,078.

To all whom it may concern:

Be it known that I, JOHN TODD, a citizen of the United States, residing at Seattle, in the county of King and State of Washington, have
5 invented certain new and useful Improvements in Reversible-Current Apparatus for Condensers, of which the following is a specification, reference being had therein to the accompanying drawings.

10 This invention relates to marine condensers and circulating-pumps and more particularly to the pipe connections thereof.

Circulating-pumps are oftentimes required for service to remove water which collects in the bilges of a marine vessel, and under prevailing conditions this water has to be discharged from such pumps through the condensers to which they are connected; but the tubes of the latter, being of relatively small
20 diameters, are extremely liable to be choked or clogged by dirt, coal, shavings, or the like which accumulate in the bilges and would be conveyed with ejected water. Under such an emergency, which frequently occurs, both the
25 pump and condenser would obviously become inert until the obstructions have been removed and which under the constructions heretofore in use require the disconnecting of the pipes and the taking off of the condenser-head and
30 which may have to be repeated a number of times at great inconvenience when done during the rolling of a vessel in a seaway and cause danger to the vessel, if not its absolute loss.

The object of my invention is to provide efficient apparatus or means to overcome the
35 aforementioned objections inherent to existing systems whereby the current of water passing through the condenser may be quickly reversed in order to dislodge obstructions collected in the mouths of the condenser-tubes
40 and convey such accumulations into the outboard water-discharge pipe and also to provide means whereby in an emergency the bilge-water may be pumped directly into the
45 said discharge-pipe without having to pass through the usual channels.

The invention consists in the several combinations or definite parts thereof hereinafter described, and set forth in the claims.

In the accompanying drawings, embodying 50 the preferred form of my invention, Figure 1 is a front elevation, partly in section, of a condenser to which the invention is attached. Fig. 2 is a longitudinal vertical section of the same, part of the condenser being broken
55 away. Fig. 3 is an enlarged transverse section taken on broken line *xy* of Fig. 2. Fig. 4 is a view illustrating the relative arrangement of circulating system for a condenser with the various suction and discharge pipe
60 connections arranged according to the present invention.

In the drawings, 2 represents a condenser-casing having a plurality of water-tubes 3 extending through the tube-sheets 4, positioned
65 adjacent the ends of the condenser. The condenser is provided with a back head 5 and a front head 6, with a cavity under each, and the cavity in the front head is divided into
70 two parts by a transverse partition 7, whereby the said tubes are divided into two series or "nests" and any water which is pumped into the cavity of the front head above or below the said partition will be caused to flow
75 through the nest of tubes entering thereat and return to the front through the other nest. The water thus flowing or "circulating" through the condenser is admitted and ejected
80 through pipe connections 8 and 9, entering the front head, and the steam being condensed is admitted at an inlet 10 and drawn off through an outlet 11 of the casing.

All of the before-described parts are common to surface condensers when used for marine purposes, as is also the use of a circulating-pump, (designated by 12 in Fig. 4,) and
85 which is provided with a sea-inlet pipe 13, having a globe or like valve 14, and a bilge suction-pipe 15, which should have a non-return valve at 16.

The numeral 17 denotes a valve-casing 90 which is provided with a port-opening 18, leading from the pump delivery-pipe 19, a port-opening 20, which leads to the outboard discharge-pipe 21, and port-openings 22 and
95 23, which are connected by the pipes 8 and 9 with the condenser. Rotatably fitted within the valve-casing is a valve substantially as

shown in Figs. 2 and 3 and consisting of a pipe member 24, which extends diametrically across the bore of its casing 17 and adapted to be oscillated or tilted to various predetermined inclinations, according to the direction or channel in which it is desired to cause the water entering at 18 from the pump to flow. For example and under the construction illustrated, when the valve is horizontal communication is made, through the bore 25 of the valve, between the pump delivery-pipe 19 and the outboard discharge-pipe 21; but when the said valve is inclined, as indicated by full and broken lines in Fig. 3, then the water is caused to flow through pipes 8 or 9, respectively, and be returned to the valve-casing through 9 or 8, as the case may be, and thence into the outboard discharge-pipe. The valve is preferably provided with two disk flanges 26 to furnish a better seating therefor within the casing-bore and is operated by an arm 27, rigidly secured to the outer end of a stem 28, formed or provided upon the valve and projecting through a suitable stuffing-box, such as 29.

The operation of the invention will be understood from the foregoing. It may be mentioned, however, that the pump may just as well be connected to the condenser in such a way as to suck or draw the water therefrom instead of forcing it into the same, as hereinbefore described, and under such circumstances the only necessary changes would be in making the pump connections intermediately of the outboard discharge-pipe.

Having described my invention, what I claim as new, and desire to secure by Letters Patent, is—

1. An apparatus of the character described, comprising a condenser having two series of condensing-tubes which at one end communicate with a common chamber and at the other end with separate and independent chambers, a casing, conduits connecting the separate chambers with the casing, an inlet and an outlet pipe communicating with the casing and a valve within the casing having means whereby the flow from the inlet-pipe may be passed directly to either one of the separate and independent chambers and the outlet-pipe connected to the other of the separated chambers, whereby the flow through the two series of tubes may be reversed.

2. An apparatus of the character described, comprising a condenser having two series of condensing-tubes which at one end communicate with the common chamber and at the other end with separate and independent chambers, a casing, conduits connecting the separate chambers with the casing, an inlet and an outlet pipe communicating with the casing, and a valve within the casing having three passage-ways whereby the inlet-pipe may be connected to either one of the separate and independent chambers and the outlet-pipe connected to the other of the separate chambers or the inlet-pipe connected directly to the outlet-pipe without the flow passing through the condensing-tubes.

In testimony whereof I affix my signature in presence of two witnesses.

JOHN TODD.

Witnesses:

PIERRE BARNES,
HENRY S. NOON.