



Europäisches Patentamt
European Patent Office
Office européen des brevets



(11) **EP 1 084 809 B1**

(12) **EUROPEAN PATENT SPECIFICATION**

(45) Date of publication and mention
of the grant of the patent:
04.06.2003 Bulletin 2003/23

(51) Int Cl.7: **B29B 7/74**, B29B 7/76,
B05B 9/01, B05B 7/12,
B05B 1/30

(21) Application number: **00119259.0**

(22) Date of filing: **06.09.2000**

(54) **Delivery gun for delivering polyurethane mixed with a forming gas**

Spritzpistole zum Austragen von einem Gemisch aus Polyurethan und Gas

Pistolet pulvérisateur pour dispenser du polyuréthane mélangé avec un gaz

(84) Designated Contracting States:
**AT BE CH CY DE DK ES FI FR GB GR IE IT LI LU
MC NL PT SE**

(30) Priority: **15.09.1999 IT MI990573 U**

(43) Date of publication of application:
21.03.2001 Bulletin 2001/12

(73) Proprietor: **Rigo S.r.l.**
21057 Olgiate Olona (Varese) (IT)

(72) Inventor: **Rigolio, Riccardo**
21057 Olgiate Olona (Varese) (IT)

(74) Representative: **Cicogna, Franco**
Ufficio Internazionale Brevetti
Dott.Prof. Franco Cicogna
Via Visconti di Modrone, 14/A
20122 Milano (IT)

(56) References cited:
EP-A- 0 903 211 **DE-A- 3 518 492**
DE-A- 3 710 395 **US-A- 5 683 544**
US-A- 5 687 913

EP 1 084 809 B1

Note: Within nine months from the publication of the mention of the grant of the European patent, any person may give notice to the European Patent Office of opposition to the European patent granted. Notice of opposition shall be filed in a written reasoned statement. It shall not be deemed to have been filed until the opposition fee has been paid. (Art. 99(1) European Patent Convention).

Description**BACKGROUND OF THE INVENTION**

[0001] The present invention relates to a delivery gun, which has been specifically designed for delivering polyurethane to which a propelling and foaming gas has been added.

[0002] As is known, for applying foamed polyurethane, a delivery gun is conventionally used, which allows to deliver or meter the polyurethane material held in a holding vessel together with the foaming gas.

[0003] The product, exiting the gun in the form of a foam, can be used and applied in an adjustable manner.

[0004] Prior polyurethane delivery guns comprise a gun body, to which a polyurethane bottle can be coupled, which communicated with the inside of a tubular element perforated at its free end portions and there-through a sliding rod is caused to pass.

[0005] The mentioned rod is provided with a conical end portion, adapted to plug or shut-off the perforated end portion, also conical, of the mentioned tubular element.

[0006] By sliding the rod, an annular opening at the end portion of the tubular element is disengaged, thereby allowing the polyurethane material and foaming agent held in the tubular element and coming from the bottle to exit.

[0007] The rod displacement amount controls the size variation of the annular opening and, accordingly, the delivered polyurethane amount.

[0008] Thus, an operator can, by operating a trigger lever, coupled to the rod, easily adjust the delivered or metered polyurethane amount.

[0009] In order to provide a limit of stroke feature, during the opening movement, of the rod, the delivery gun comprises a bottom element which can be screw coupled to the body of the gun, thereby, by screwing on or off said bottom element, the position of the latter with respect to the gun body can be easily adjusted, thereby also adjusting the limit of stroke position of the rod.

[0010] The above disclosed adjustment bottom element construction is affected by some drawbacks, of constructional nature, and, most importantly, can cause the bottom element to be accidentally disengaged during the gun use.

SUMMARY OF THE INVENTION

[0011] Accordingly, the aim of the present invention is to provide such a delivery or metering gun, allowing to overcome the above mentioned drawbacks.

[0012] Within the scope of the above mentioned aim, a main object of the present invention is to provide such a delivery gun including an improved system for adjusting the limit of stroke position of the rod thereof.

[0013] Another object of the present invention is to provide such a delivery or metering gun, in which the

bottom element is not screw engaged.

[0014] According to one aspect of the present invention, the above mentioned aim and objects, as well as yet other objects, which will become more apparent hereinafter, are achieved by a delivery gun, specifically designed for delivering foamed polyurethane, comprising a gun body, including a delivery tubular element, communicating with a material to be delivered vessel, and adapted to be coupled to said body, a sliding rod longitudinally sliding in said tubular element and having a conical end portion for engaging a delivery opening, said rod being adapted to disengage said opening during a backward movement thereof, the stroke of said rod being limited by end of stroke limit means and being characterized in that said end of stroke limit means comprise a rotary element, coupled to said body, and adapted to be driven from the outside, said rotary element being kinematically coupled to an abutment element, slidable with respect to said body, due to the rotary movement of said rotary element, and adapted to define the rear limit of stroke position of said rod.

BRIEF DESCRIPTION OF THE DRAWINGS

[0015] Further characteristics and advantages of the present invention will become more apparent hereinafter from the following detailed disclosure of the delivery gun according to the invention, which is illustrated, by way of an indicative, but not limitative, example, in the accompanying drawings, where:

Figure 1 is a cross-sectioned side view of a delivery gun according to the invention;

Figure 2 is a partial enlarged and cross sectioned elevation view of that same delivery gun shown in Figure 1;

Figure 3 is an enlarged detail front view of the abutment element;

Figure 4 is an enlarged detail side view of the abutment element;

Figure 5 is a further enlarged detail side view of the bottom element-abutment element-end rod assembly.

DESCRIPTION OF THE PREFERRED EMBODIMENT

[0016] With reference to the number references of the above mentioned figures, the delivery gun according to the present invention, generally indicated by the reference number 1, comprises a gun body 2 provided with a fitting 3 for a vessel 4 adapted to hold therein a material to be delivered or metered, for example a polyurethane and foaming gas bottle.

[0017] To the body 2 an extension element 5 can be coupled, said extension element comprising a tubular element including a free end portion with a delivery opening 6 having a conical longitudinal cross-section.

[0018] The inner cavity of the tubular element 5 is cou-

pled to the vessel 4 through a duct 8, thereby the material to be delivered can pass to the delivery opening 6 to be metered or delivered.

[0019] A delivery rod 7 is arranged in the cavity of the tubular element 5 and can longitudinally slide therein.

[0020] More specifically, said rod 7 has a conical front end portion, for shutting-off the delivery opening 6 in its closure position and, by backward sliding, being adapted to adjustably open the delivery opening 6, due to the tapering or conicity of said rod.

[0021] The back sliding of the rod 7 is controlled by an operating or driving lever 9, coupled to the gun body 2 and which can be manually operated by the user, gripping the delivery gun by a gun grip portion 10.

[0022] The rear end portion 11 of the rod 7 is adapted to engage in a blind hole 13 of an abutment element 12, which can slide in the gun body 2.

[0023] An annular recess 14 of the abutment element 12 is adapted to receive therein an end portion of a coil spring 15 coaxial with the rod 7 and having the other end portion thereof abutting against a flange 16 of the rod 7.

[0024] Thus, the coil spring 15 will drive the rod 7 to be closure position thereof.

[0025] The abutment element 12 can slide in the gun body 2, but it cannot turn about its longitudinal axis, through guides 17 formed in the gun body 2 and is provided with a threaded portion 18, adapted to engage a ring-nut 20 formed in a rotary element 19.

[0026] The latter comprises a bottom element, on the outside of the gun body 2, and which can be turned or rotated by the operator in order to axially drive or displace the abutment element 12 thereby adjusting the end of stroke position of the rod 7.

[0027] The rotary element 19, in particular, can be snap assembled on the gun body 2, to be able of rotating, without disengaging or longitudinally moving.

[0028] The operation of the delivery gun according to the present invention would be very simple.

[0029] Actually, it would be sufficient to apply a polyurethane bottle to the fitting 3, in a per se known manner, and operate the lever 9 to deliver the desired product amount, by adjusting the displacement of the rod by operating said lever.

[0030] The maximum amount of product which can be delivered or metered will depend on the end of stroke position of the rod 7, which can be easily adjusted by turning the rotary element 19.

[0031] The latter can comprise signalling elements for signalling the end of stroke or limit position, such as notches or other indicating marks, allowing a user to easily detect the position of the adjusting element.

[0032] Thus, it should be apparent that the invention fully achieves the intended aim and objects, since the subject delivery gun can be easily adjusted by a bottom element for adjusting the maximum delivered amount, said bottom element turning with respect to the gun body, without threading on or off.

[0033] Thus, the mentioned bottom element cannot be accidentally disengaged or unthreaded.

[0034] In practicing the invention, the used materials and size can be varied, according to requirements and the status of the art.

Claims

- 10 1. A delivery gun (1) for delivering foamed polyurethane, comprising a gun body (2), including a delivery tubular element (5), communicating with a material to be delivered vessel (4), and adapted to be coupled to said body (2), a sliding rod (7) longitudinally sliding in said tubular element and having a conical end portion for engaging a delivery opening (6), said rod (7) being adapted to disengage said opening (6) during a backward movement thereof, the stroke of said rod (7) being limited by end of stroke limit means and being **characterized in that** said end of stroke limit means comprise a rotary element (19), coupled to said body (2), and adapted to be driven from the outside, said rotary element (19) being kinematically coupled to an abutment element (12), slidable with respect to said body (2), as said rotary element is rotatively manually driven, and adapted to define the rear limit of stroke position of said rod (7).
- 15 2. A delivery gun (1) according to Claim 1, **characterized in that** said rod (7) is provided with a rear end portion adapted to engage in a blind hole (13) of said abutment element (12), and that said abutment element (12) comprises an annular recess (14), for housing therein an end portion of a coil spring (15), coaxial with said rod (7), the other end portion of said coil spring (15) abutting against a flange (16) of said rod, thereby to cause said rod (7) to be arranged at a closure position thereof.
- 20 3. A delivery gun (1) according to Claim 1 or 2, **characterized in that** said abutment element (12) is slidably arranged in said gun body (2), and cannot turn about its longitudinal axis, by guides (17) formed in said gun body (2), and being provided with a threaded portion (18) for engaging a ring-nut (20) formed in said rotary element (19).
- 25 4. A delivery gun (1) according to one or more of the preceding claims, **characterized in that** said rotary element (19) comprises signalling elements for indicating or the position of said abutment element (12).

Patentansprüche

1. Spritzpistole (1) zum Austragen von Polyurethan-

schaum, die einen Pistolenkörper (2) mit einem rohrförmigen Austragsselement (5), das mit einem auszutragendes Material enthaltenden Behälter (4) in Verbindung steht und das so angepasst ist, dass es mit dem Körper (2) verbunden werden kann, und eine in Längsrichtung in dem rohrförmigen Element entlang gleitend bewegbare Gleitstange (7) mit einem konischen Endabschnitt zur Ineingriffnahme einer Austragsöffnung (6) aufweist, wobei die Stange (7) so angepasst ist, dass sie die Öffnung (6) während einer Rückwärtsbewegung derselben freigibt, wobei der Hub der Stange (7) durch Hubendstellungs-Begrenzungseinrichtungen begrenzt ist, **dadurch gekennzeichnet, dass** die Hubendstellungs-Begrenzungseinrichtungen ein mit dem Körper (2) verbundenes Drehelement (19) umfassen, das so angepasst ist, dass es von außen angetrieben werden kann, wobei das Drehelement (19) kinematisch mit einem Anschlageelement (12) verbunden ist, das im Verhältnis zu dem Körper (2) gleitend bewegbar ist, wenn das Drehelement manuell mit einer Drehbewegung angetrieben wird, und so angepasst ist, dass es die hintere Begrenzung der Hubposition der Stange (7) festlegt.

2. Spritzpistole (1) nach Anspruch 1, **dadurch gekennzeichnet, dass** die Stange (7) mit einem hinteren Endabschnitt versehen ist, der so angepasst ist, dass er in einem Sackloch (13) des Anschlageelementes (12) in Eingriff geht, und dass das Anschlageelement (12) eine ringförmige Ausnehmung (14) aufweist, um darin einen Endabschnitt einer koaxial zu der Stange (7) verlaufenden Spiralfeder (15) aufzunehmen, wobei der andere Endabschnitt der Spiralfeder (15) gegen einen Flansch (16) der Stange anliegt und dadurch die Positionierung der Stange (7) in ihrer Verschlussposition veranlasst.
3. Spritzpistole (1) nach Anspruch 1 oder 2, **dadurch gekennzeichnet, dass** das Anschlageelement (12) mittels in dem Pistolenkörper (2) ausgebildeter Führungen (17) gleitend bewegbar in dem Pistolenkörper (2) angeordnet ist, mit einem Gewindeabschnitt (18) zur Ineingriffnahme einer in dem Drehelement (19) ausgebildeten Ringmutter (20) versehen ist und sich nicht um seine Längsachse drehen kann.
4. Spritzpistole (1) nach einem oder mehreren der vorangegangenen Ansprüche, **dadurch gekennzeichnet, dass** das Drehelement (19) Signalgeberelemente zum Anzeigen der Position des Anschlageelementes (12) umfasst.

Revendications

1. Pistolet pulvérisateur (1) pour dispenser une mousse polyuréthane, comprenant un corps pulvérisateur (2), incluant un élément tubulaire pulvérisateur (5), communiquant avec un récipient (4) contenant un matériau à pulvériser, et adapté pour être couplé audit corps (2), une tige de coulissement (7) coulissant longitudinalement sur ledit élément tubulaire et présentant une partie d'extrémité conique pour engager une ouverture (6) de pulvérisation, ladite tige (7) étant adaptée pour désengager ladite ouverture (6) lors d'un mouvement vers l'arrière de celle-ci, la course de ladite tige étant limitée par un moyen d'extrémité de limite de course et étant **caractérisé en ce que** ledit moyen d'extrémité de limite de course comprend un élément rotatif (19), couplé audit corps (2), et adapté pour être actionné de l'extérieur, ledit élément rotatif (19) étant couplé de manière cinétique à un élément de butée (12), coulissant par rapport audit corps (2), puisque ledit élément rotatif est actionné manuellement de manière rotative, et est adapté pour définir la limite arrière de la position de course de ladite tige (7).
2. Pistolet pulvérisateur (1) selon la revendication 1, **caractérisé en ce que** ladite tige (7) est munie d'une partie d'extrémité arrière adaptée pour s'engager dans un logement à fond plein (13) situé dans ledit élément de butée (12), et **en ce que** ledit élément de butée (12) comprend un creux annulaire (14), pour y loger une partie d'extrémité d'un ressort hélicoïdal (15), coaxial avec ladite tige (7), l'autre partie d'extrémité dudit ressort hélicoïdal (15) butant contre un rebord (16) de ladite tige, de ce fait entraînant ladite tige (7) dans une position fermée.
3. Pistolet pulvérisateur (1) selon la revendication 1 ou 2, **caractérisé en ce que** ledit élément de butée (12) est disposé de manière coulissante dans ledit corps de pistolet (2), et ne peut pas tourner autour de son axe longitudinal, au moyen de guides (17) formés dans ledit corps de pistolet (2), et étant muni d'une partie filetée (18) pour engager un écrou (20) formé dans ledit élément rotatif (19).
4. Pistolet pulvérisateur (1) selon l'une quelconque des revendications précédentes, **caractérisé en ce que** ledit élément rotatif (19) comprend des éléments de détection afin d'indiquer la position dudit élément de butée (12).

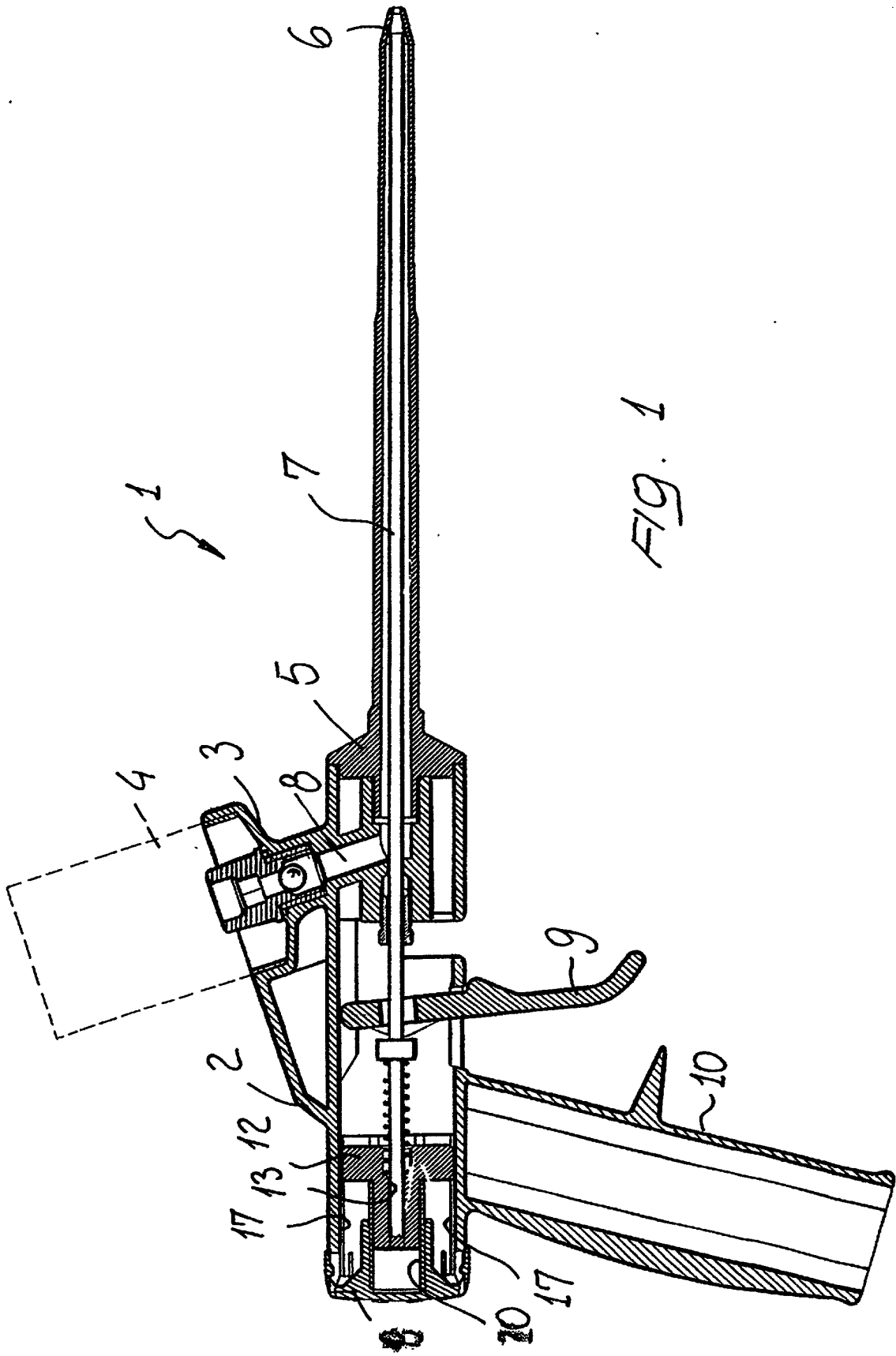

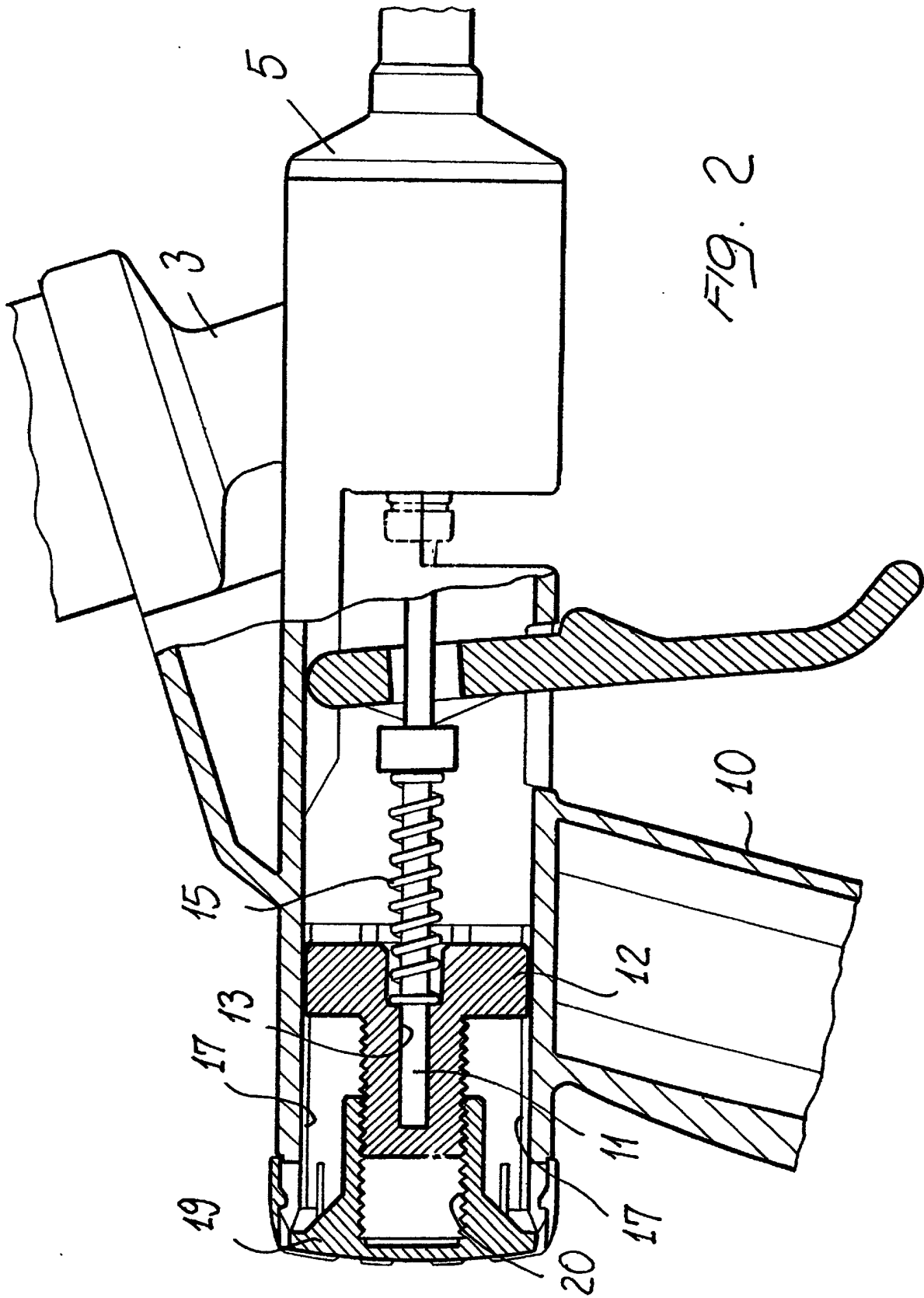

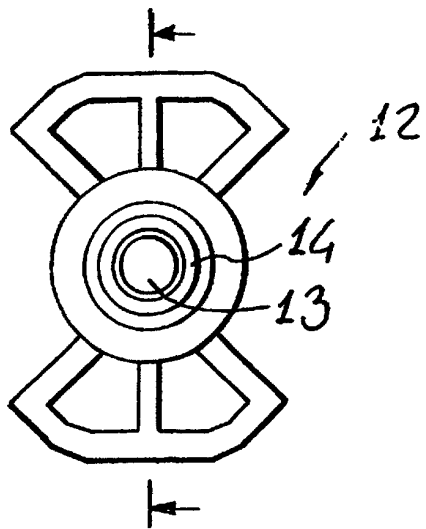

FIG. 3

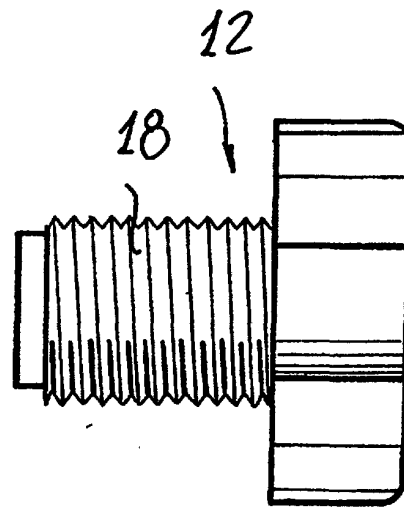

FIG. 4

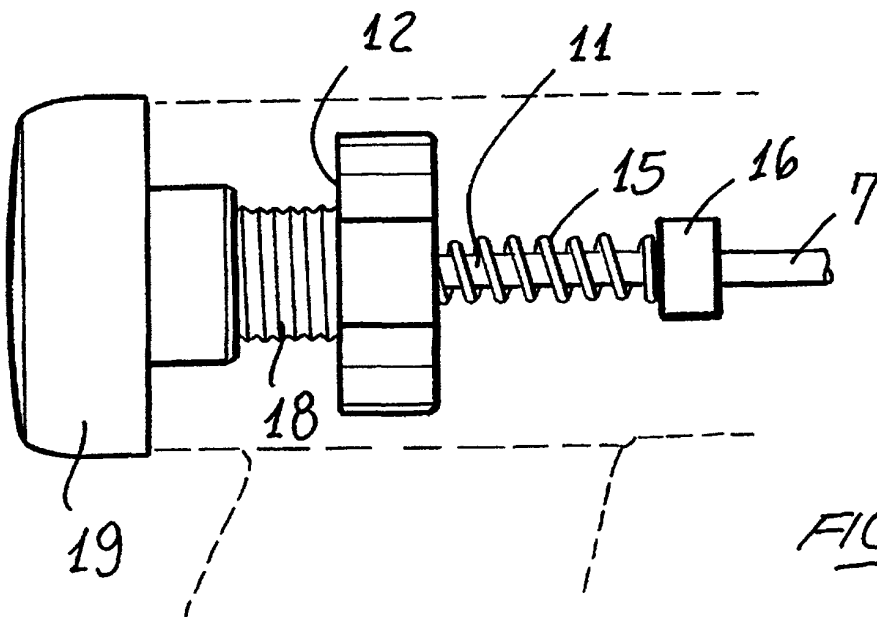

FIG. 5