

Emery & Leverich,

4, Sheets, Sheet 1.

Steam Towing.

No. 104,439.

Patented June 21, 1870.

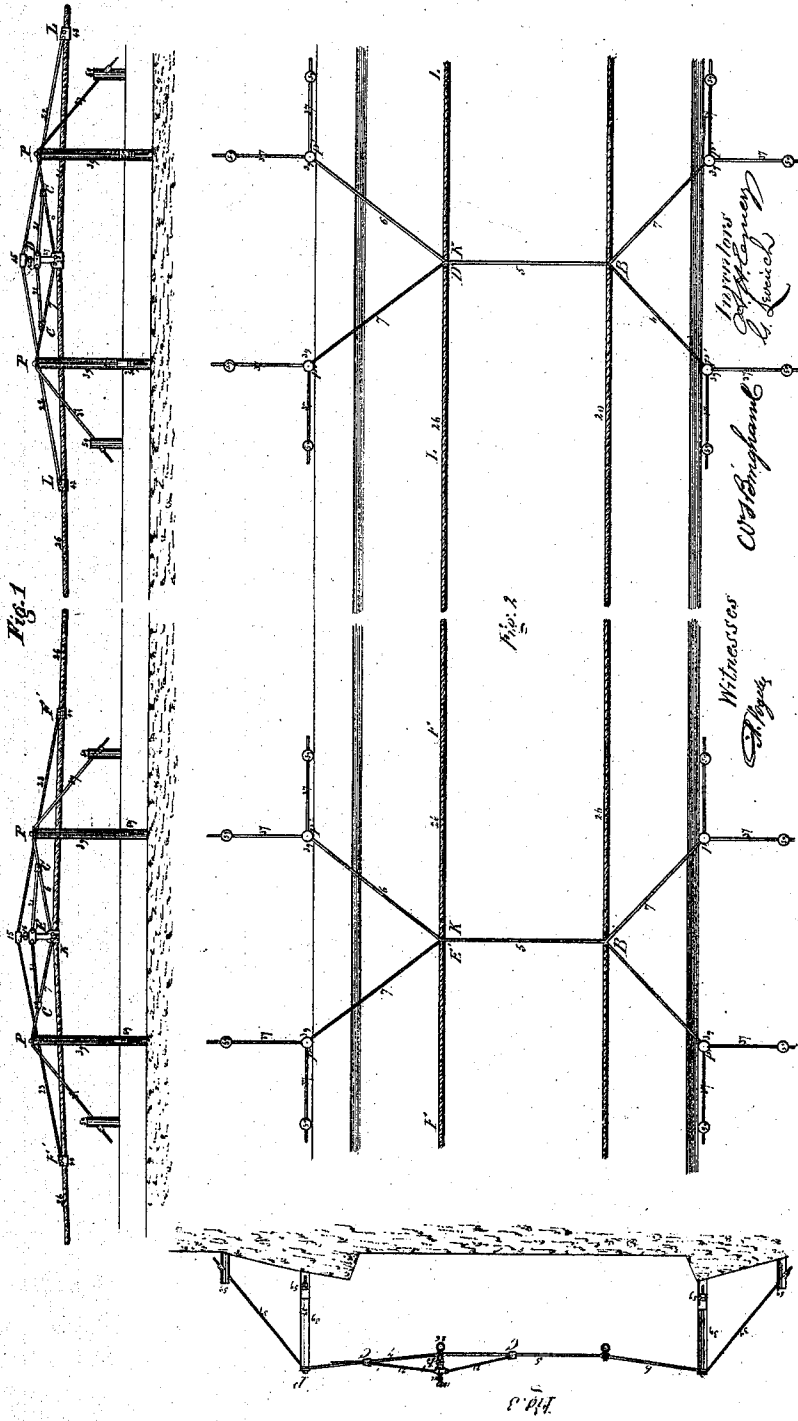

4. Sheets, Sheet 2.  
Emery & Leverick,

Steam Towing.

No. 104,439.

Patented June 21, 1870.

Fig 6

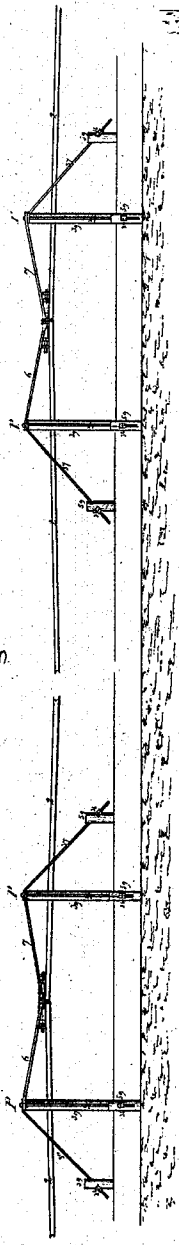
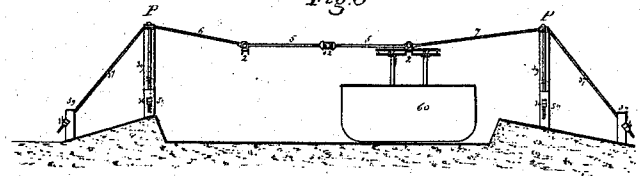

Fig 4

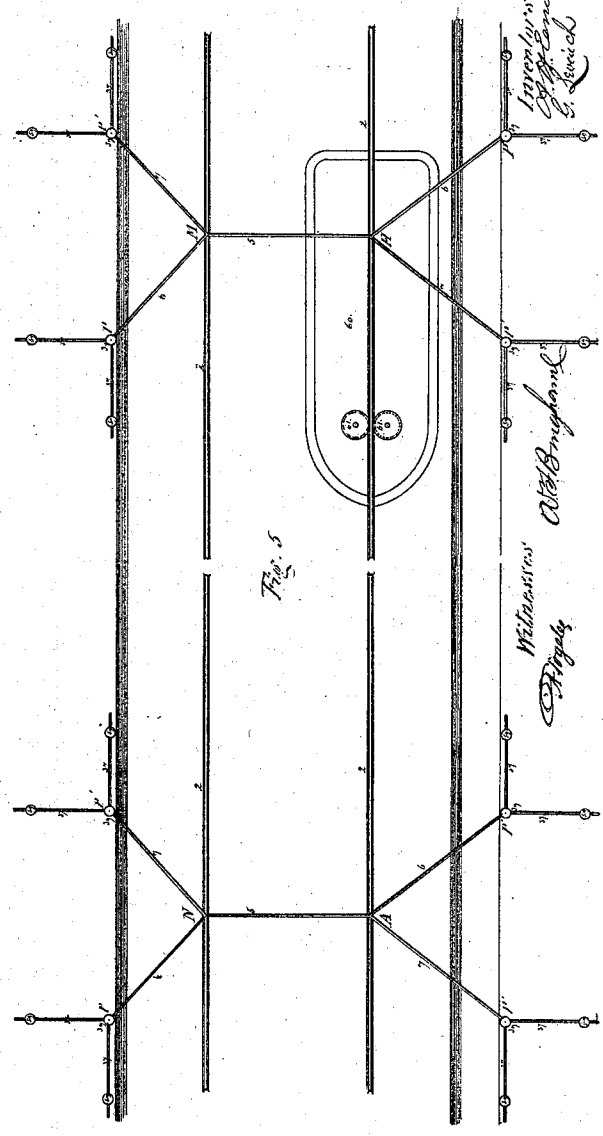

Fig 5

Inventors  
Emery & Leverick

Witnesses  
Wm. B. ...

Wm. B. ...

Emery & Leverick, 4, Streets, Street 3,

Steam Towing.

No. 104,439.

Patented June 21, 1870.

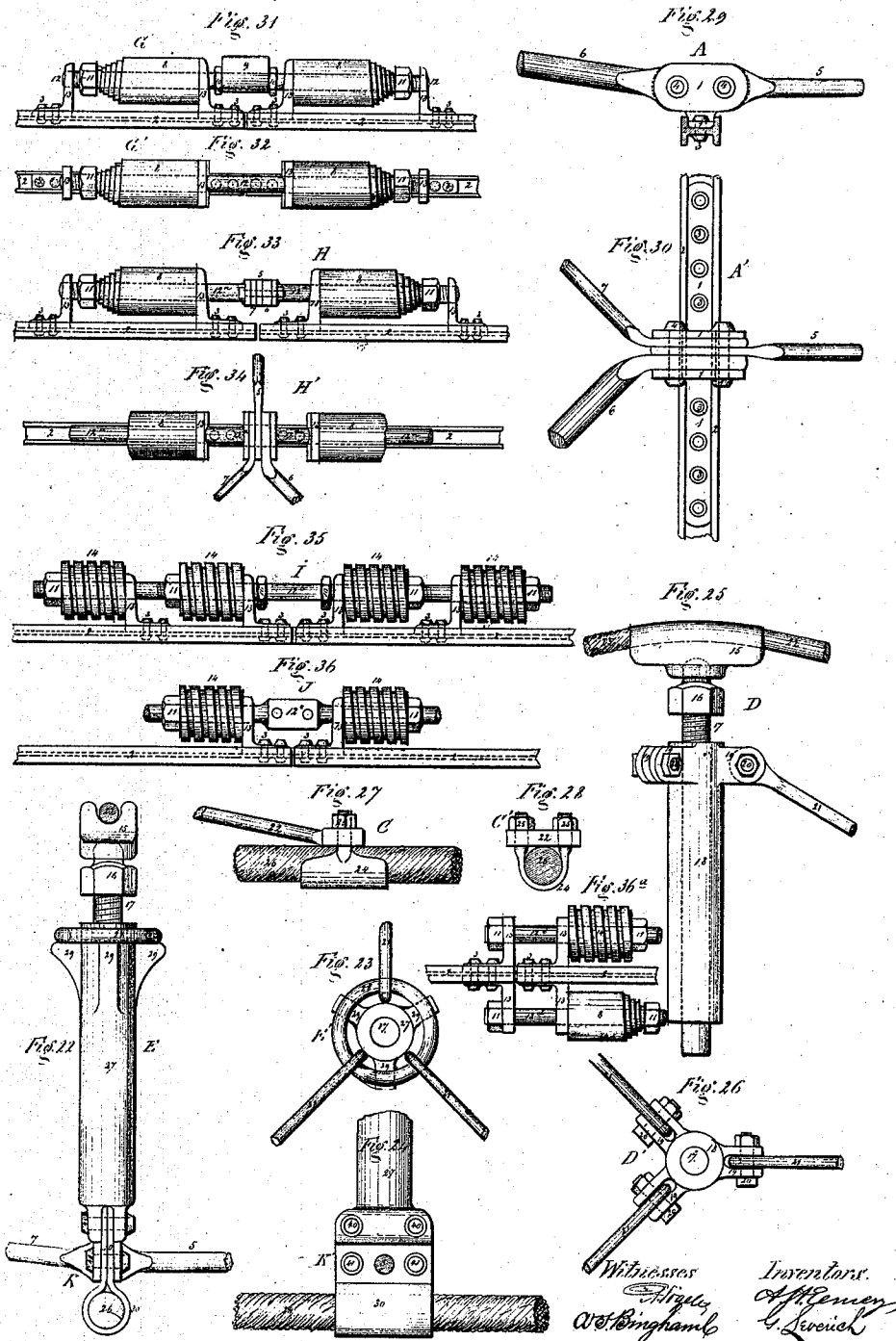

Emery & Levertich, 4, South Street, 4.

Steam Towing.

No. 104,439.

Patented June 21, 1870.

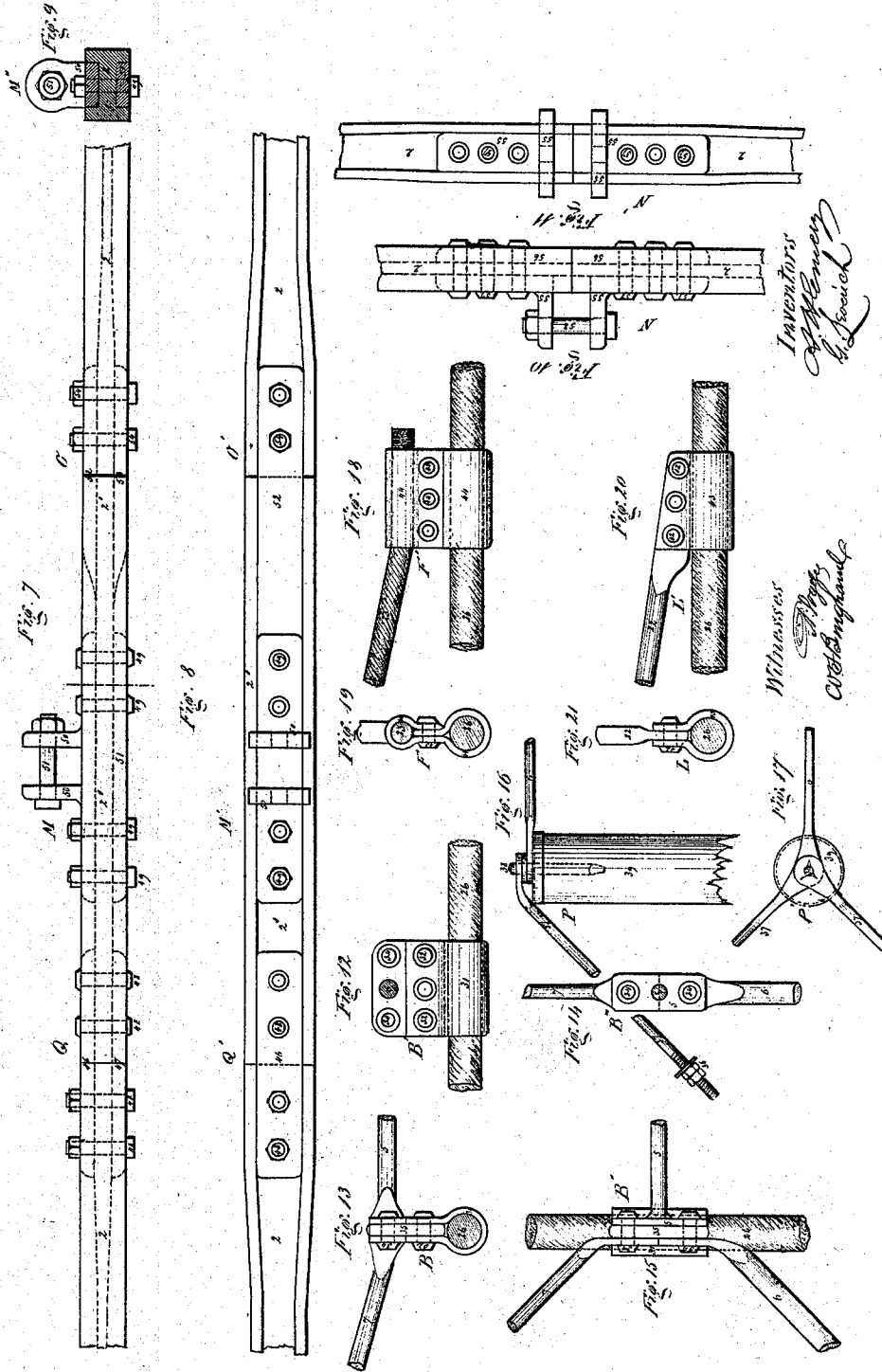

# United States Patent Office.

ALBERT H. EMERY AND GABRIEL LEVERICH, OF NEW YORK, N. Y.

Letters Patent No. 104,439, dated June 21, 1870.

## IMPROVEMENT IN APPARATUS FOR TOWING CANAL-BOATS.

The Schedule referred to in these Letters Patent and making part of the same.

We, ALBERT H. EMERY and GABRIEL LEVERICH, both of the city, county, and State of New York, have invented a new and improved System of Steam Towing on Canals, of which the following is a specification.

Our invention consists in providing means to tow or propel boats on canals and navigable rivers, without the propelling power acting directly upon the water, by the use of rails, cables, or chains suspended across or over the canal or river, at suitable distances apart, which sustain other rails, cables, or chains suspended therefrom over the canal or river, and running parallel thereto the entire length, and at a height sufficient to allow the boats to run under the same; also, by the use of engines and machinery placed in the boat or boats, of such kind and construction as shall be necessary to work on said suspended rails, cables, or chains in a way to propel the boat or boats.

The first part of the invention, viz., that relating to the construction, suspension, operation, and use of the rails, cables, or chains suspended over the canals, with all the details necessary therefor, is the part of the invention treated of in this specification; while

The second part of the invention, viz., that relating to the construction and operation of the machinery placed in the boat, which acts on the said rails, cables or chains, to propel the boat, will be made the subject of another patent, and will not be described here.

To enable others skilled in the art to make use of our invention, we will proceed to describe the precise construction and operation of the first part thereof.

There are four sheets of drawing making part of this specification.

In all the drawing like figures represent like parts.

On Sheet No. 1, Figures 1, 2, and 3 represent, respectively, a side elevation, plan, and end elevation of a portion of the canal, with wire cables suspended over it, and parallel thereto, together with the rods, &c., supporting the cables.

Sheet No. 2 shows, in Figures 4, 5, and 6, respectively, a side elevation, plan, and end elevation of a portion of the canal, with a section or span of the rails suspended over the same, together with the supporting-rods, &c.; also, a boat, showing, in plan and end elevation, the method of connecting the machinery with the rails.

Sheets 3 and 4 show different parts of the rails, cables, and rods, with the methods of constructing and attaching the same, together with all the details necessary thereto.

On sheets 1 and 2 No. 39 shows, at P and P, the several elevations and plans of posts erected on the sides of the canal. They are driven firmly in the earth as piles, or set in masonry or timber, as may be found most convenient at the place of erection. They should be made firm in their setting, to provide especially

against settling, as a heavy downward pressure is put upon them. They may be made of cast iron. If made of wood, they should be treated by the Robbins, or other reliable process, to prevent decay.

When made of wood, they should be capped on the upper end with a cast-iron cap, as shown in Figures 16 and 17, Sheet No. 4.

Through this cap an iron rod or bolt, No. 38, shown only in figs. 16 and 17, Sheet No. 4, runs into the posts. This bolt secures brace-rods No. 37, shown in figs. 16 and 17, Sheet No. 4, and in all the figures of sheets Nos. 1 and 2. These brace-rods No. 37 must be firmly anchored to contiguous rocks, or to masonry, timbers, or castings placed in the ground.

In many cases, they may be advantageously secured by driving piles firmly into the ground, then passing the brace-rods No. 37 through them, and drawing up tightly by means of washers and nuts. These piles to anchor the brace-rods are shown in all of the figures on Sheets Nos. 1 and 2, and are pieces No. 59.

Having firmly secured four of the posts No. 39 in their position, two on one side of the canal and close to the edge of the water, and two on the opposite side just outside of the tow-path, and at suitable distances from each other, we next suspend five metal rods, (usually of iron,) pieces Nos. 6, 7, 5, 6, and 7, across the canal, and secure them to the tops of the posts No. 39, as shown in figs. 16 and 17, Sheet No. 4, and of such lengths that piece No. 5 will hang about one foot below the top of the posts No. 39. The posts should be of such length that the rod 5 will not be lower than the under side of the bridges over the canal. It should usually be a few inches higher. Rod No. 5 should have a turn-buckle placed in it, (piece 62,) as shown in fig. 6, sheet 2. The two adjoining posts should be placed so that the angle at B, sheet 1, between the rods 6 and 7, is about ninety degrees, the relations between the lengths, included angle, and consequent strain upon them, being such that, with this angle, the least amount of material is required in them.

Having secured one set of four posts, No. 39, by their braces No. 37, and suspended the rods Nos. 6 7 5 6 7, we next erect another set of four posts, No. 39, and secure by braces No. 37, anchored, as before, and suspend from their top rods 6, 7, 5, 6, and 7, as before, and continue thence these sets, at suitable distances, over the entire canal. We usually put the posts in such positions as to bring rods No. 5 from one hundred and fifty to two hundred and fifty feet apart. A distance of two hundred feet is very good.

If the traffic is not large on the canal, we may dispense with piece No. 5, and use but one rail or cable parallel with the canal. Boats running either way will then make use of the same cable; but, when the

traffic is large we prefer two cables or rails, as shown in all the plans on Sheets Nos. 1 and 2, when two cables or rails are used, so that boats running one way always make use of the same cables or rails, and boats running the other way always use the other. We may make rods 6 and 7 of different sizes, proportional to the strain that shall come on them; but these strains are the same if boats run both ways on the same cable or rail.

Pieces Nos. 5, 6, and 7, are connected, as shown at A, fig. 5, sheet 2, and A A', Figures 29 and 30, sheet 3, where they are bolted or riveted to piece 1, by means of bolts or rivets No. 4; or they are fastened together as shown at B, fig. 2, Sheet No. 1, and B B', Figures 12, 13, 14, and 15, sheet 4, where they are riveted or bolted to piece No. 35 by rivets or bolts No. 34.

They may also be fastened together, as shown, by being made of the form shown in figs. 13 and 14, sheet 4, and then riveted or bolted to piece No. 12', Figure 36, sheet 3, or to piece No. 30, Figures 22 and 24, sheet 3.

They may be fastened together, also, by being strung on the bolts No. 51, Figures 7, 8, and 9, sheet 4, or on bolt No. 58, Figure 10, sheet 4, or bolts No. 12', Figure 35, sheet 3, where they are held in position by lock-nuts No. 10; or, they are bolted or riveted together by two bolts passing through them, and pieces 12', as shown in Figures 33 and 34, Sheet No. 3, suspended over the canal, and parallel thereto, on the cables 26 26, shown in plan, and two elevations in figs. 1, 2, and 3, sheet 1; or the rails 2 2, shown in figs. 4, 5, and 6, in elevation, plan, and elevation in figs. 4, 5, and 6, sheet 2.

A chain may be used instead of cable or rail, but we prefer rails of suitable section. The H-section has many advantages over all other forms for this purpose, on account of the facility of splicing and supporting it, without the splicing and supports interfering with the machinery that runs upon or against it. When an H-section rail is used, the machinery used to run against it to propel the boat is much simpler than if a cable is used, and both the machinery and rails are much more durable than are the cables, and the machinery necessary to work with them.

The cables are suspended by passing through the loops or bands, pieces No. 30, figs. 22 and 24, sheet 3, or by passing through pieces No. 31, figs. 12, 13, and 15, sheet 4, in each of which cases the band is firmly fixed to the cable by means of the rivets or bolts 41--41 in figs. 22 and 24, or 32--32 in figs. 12, 13, and 15.

These band 30 and 31 may, if necessary to prevent slipping through them, be soldered to the cables.

These bands are fixed, by rivets or bolts, to pieces No. 35, 5, 6, and 7. The rails 2 2 are suspended, by being bolted or riveted, to pieces No. 50--50 by bolts or rivets No. 49, as shown in figs. Nos. 7, 8, and 9, at M, sheet 4, by being bolted or riveted to pieces No. 55 by bolts or rivets No. 57, figs. 10 and 11, sheet 4, by being bolted or riveted to pieces No. 13 by bolts or rivets No. 3, shown in figs. 31, 32, 33, 34, 35, and 36, where pieces Nos. 50, 55, and 13 are supported by the bolts Nos. 51, 58, or 12', which pass through the ends of pieces 5, 6, and 7, or by bolt No. 12, secured to pieces 5, 6, and 7, by passing through the band No. 9, which is riveted or bolted to Nos. 5, 6, and 7, and where 12 is kept from slipping in No. 9 by the use of the nuts Nos. 10 10. Or pieces Nos. 50, 55, and 13 are supported by bolts 12 and 12', bolted or riveted directly to pieces 5, 6, and 7.

Rails No. 2 2 may also be supported as shown in Figures 29 and 30, sheet 3, where they are bolted or riveted directly to piece No. 1 by bolts or rivets No. 3, this piece No. 1 being bolted or riveted directly to pieces Nos. 6, 5, and 7 by bolts or rivets No. 4.

Piece No. 1, figs. 29 and 30, sheet 3, and piece No.

50, figs. 7 and 8, sheet 4, may each be made of one piece, or they may, for convenience of manufacture, be made in two pieces.

In one span of the rails 2 2, reaching from A to H, fig. 5, sheet 2, each rail is usually made up of a short heavy piece, 2', from four to ten feet long at joints A and H, and two long pieces, about one hundred feet long, spliced together at the center of the span, and spliced to the heavy pieces 2' at A and H.

This heavy piece 2' at the place of support is needed on account of the extra strain at that place.

This splicing is accomplished as shown at O and Q in figs. 7 and 8, sheet 4, where we make a splice in such a way as not to weaken the rail, by first upsetting the end of the small rail sufficiently to make the holes for the bolts or rivets 48 and 54 without reducing the section of the rail below the average section elsewhere, and then bolt or rivet the rails together by means of the bolts or rivets 48 and 54 and pieces 46 and 47, or 52 and 53.

The pieces 46 and 47, or 52 and 53, should fill the space between the flanges of the rail, and be of such thickness that, after they have been drilled for the bolts 48 or 54, their minimum section will be equal to the average section of the long rails.

The pieces 52 and 53 are welded to the end of the long rail, to avoid riveting or bolting.

The heavy rail is, of course, weakened by the rivets or bolts passing through it, but is still as strong as the light rail at its average section.

The rails or cables are put under heavy tension when erected, so as to bring them up to a nearly horizontal position; but a rail of two hundred feet in length may sag one or two feet in the center.

Both rails and cables are constantly changing their length on account of the change of temperature; and this change of length changes the sag or deflection of the rail or cable.

Should this change or deflection be so much as to trouble us, it may be corrected in the rail by making the joint at the point of support, as shown in figs. 31 and 32, or 33 and 34, where the strains on the rails 2 2 are carried by the lugs 13 to the springs No. 8; thence to nuts No. 11 and bolts 12 or 12'.

It will be observed that, as the rails contract, they will compress the springs (if these are properly proportioned) without increasing the strains on the rails sufficiently to injure them; and, when the rails expand, the springs expand also, and so keep the rails from sagging too much.

In fig. 33, we show four springs to a single joint, whereby the strain on such spring is but half as much.

In figs. 35 and 36, we show a steel coil-spring, No. 14, filled with rubber, while in figs. 31, 32, 33, and 34 we show involute springs, No. 8; but any convenient form which is sufficiently stiff, and not too bulky, may be used.

The joint may be made as at fig. 36, except with the springs left out, and the deflection adjusted from time to time, as the temperature changes, by simply turning the nuts No. 11; and this bolt, if used as an adjusting-bolt, may, perhaps, better be placed at the splice in the center of the span. This joint will then best be made by placing pieces No. 13 on each side of the rail; that is, top and bottom opposite to each other, as shown at 36', and then the strains on pieces 13 will be but half as much as on those in fig. 36.

We may also arrange them in this way, and use the springs No. 14 or 8, and the loads on the springs and strains on the pieces 13 will be but half as much, and, being on opposite sides of the rail, will not strain the rail so much, there being no tendency to rotation when so placed.

We have shown in fig. 36' this joint at the center of the span, with the bolts 12' on both sides of the rails, and springs on one end of the bolt 12'. We

may use springs also on both ends, if we choose, or we may use these bolts 12<sup>a</sup> in fig. 36<sup>a</sup> without any springs, having the nuts turned from time to time, to take up or correct for expansion or contraction.

As the rail expands and deflects more, it loses part of its initial strain of tension placed therein when erected; but removing the tension from a bar allows it to contract, so that this contraction, from removal of part of the strain, tends to correct the expansion from the heat, and does correct a very sensible portion of such expansion.

In the use of long spans, we may prevent excessive deflection by the use of the elevating-pieces D and E, figs. 1 and 3, sheet 1.

The details of this arrangement are shown on sheets 3 and 4, where pieces 18 and 27, figs. 25, and 22, and 24, are made of convenient size and form to act as a post and nut. They are usually made of cast-iron, with the foot bolted to piece 30, as shown in figs. 22 and 24, sheet 3; or they may be bolted to piece 35, figs. 13 and 15, sheet 4, or piece No. 1, figs. 29 and 30, sheet 3; or they may have a tenon on their foot end, which may sit in a step prepared and fastened to any of the pieces 30, 31, and 35, or piece 1, with which they are to be used.

Piece 27, figs. 22 and 23, has supporting-lugs at the top, on which rests the ring 28, to which are secured the rods 21, shown in fig. 23, while piece 18, fig. 25, sheet 3, has these rods 21 secured by bolts 20 directly to lugs 19, cast on its upper end.

These rods 21 are fastened to rods 5, 6, and 7, as shown at C in figs. 1 and 3, sheet 1, and serve the purpose of keeping pieces 27 or 18 in an upright position.

Screwing into piece 27 or 18 are screws No. 17, turned by their heads 16, as shown in figs. 22 and 25, sheet 3, or figs. 1 and 3, sheet 1.

These screws carry a saddle-piece, No. 15, over which pass cables or rod-pieces 23 or 22, as shown at E or D in fig. 1, sheet 1.

If a cable-piece, 23, is used, it may be fastened to the main cable 26 by means of band 44 and rivets 45, as shown at figs. 18 and 19, sheet 4, where the rivets secure the band from slipping. They may be soldered in the bands, if necessary, to prevent slipping.

These attachments are shown in side elevations at F' F', fig. 1, sheet 1.

If rods 22 are used, they are attached by bands 43 and rivets 42, shown in figs. 20 and 21, sheet 4, and at L L in fig. 1, sheet 1, or by band 24 and nuts 25 25, shown in figs. 27 and 28, sheet 3, solder being used, if necessary, in each case.

When these pieces are all in their places, by turning up the screws 16 17 we raise the saddle-piece 15, and thus tighten the supporting-cables or rods 23 or 22, raising up the main cables at the points of attachment.

These elevating-pieces may also, if desired, be used in precisely the same way with the rails, only the bands 43 or 44 would be dispensed with, and rods 22 would be riveted or bolted directly to the rails.

Having erected suitable posts, rods, chains, cables, or rails, and properly secured them in their places with a suitable amount of deflection, we next place in the boat-piece, No. 60, an engine, boiler, and machinery necessary to apply and operate the two wheels Nos. 61 61, which are constructed with flanges and

faces suitable to run on chains, cables, or rails, against which they are firmly passed, to such an extent that the friction between them and the chains, cables, or rails will prevent their slipping as they roll, and, as they are rotated by the engine in the boat without slipping, they are carried along, and carry, propel, or tow the boat along with them.

The description of the machinery to run these wheels will be made the subject of another patent.

In fixing upon the proper distances between pieces 5 5, which constitute one span or section, we may, if we choose, make this distance quite large, and then provide an intermediate support or supports, which shall be of a kind simply to keep the rail or cable from sagging, which supports on curves should also sustain the cable or rail, and prevent it from movement in a horizontal direction.

Having thus described our invention,

What we here claim, and desire to secure by Letters Patent, is—

1. The combination and arrangement of the suspending-rods 6 7 5 6 7 with the suspended rails 2 2 or cables 26 26, when suspended over a canal, as and for the purposes set forth.

2. The combination and arrangement of the suspending-rods 6 7 6 7 with the suspended rail 2 or cable 26, when suspended over a canal, as and for the purposes set forth.

3. The combination and arrangement, in each span or section of the suspended rail 2, of a short heavy rail, 2, joined at each of its extremities to a long light rail, 2, substantially as and for the purposes set forth.

4. The combination and arrangement of two sets of the suspending-rods, 6 7, 6 7, and 6 7, 6 7, with the rail 2, under tension, for the purpose set forth.

5. The combination and arrangement of two sets of the suspending-rods, 6 7 5 6 7 and 6 7 5 6 7, and rails 2 2, or cables 26 26, with the rails or cables under tension, as and for the purposes set forth.

6. The combination and arrangement of the rails 2 2, lugs 13, 13, 13, 13, bolt 12<sup>a</sup>, nuts 11, 11, 11, 11, and springs 14, 14, 14, 14, as and for the purposes set forth.

7. The combination and arrangement of the cable 26, band 30, rivets 41, and supporting-rods 6, 7, 5, as and for the purposes set forth.

8. The combination and arrangement of the rail 2, lugs 1 1, supporting-rods 5 6 7, and bolts or rivets 4 4, as and for the purpose set forth.

9. The combination and arrangement of the rails 2 2, lugs 13 13, springs 8 8, bolts 12, nuts 10 10, 11 11, and suspending-rods 5 6 7, as and for the purpose set forth.

10. The combination and arrangement of the rail 2, lug 50, bolt 51, and rods 5 6 7, as and for the purposes set forth.

11. The combination and arrangement of the band 30, post 18, supporting-rods 5 6 7, fixing-rods 21 21, screw and nut 17 16, saddle 15, cable 26, and rod or cable 22, as and for the purposes set forth.

A. H. EMERY.  
GABRIEL LEVERICH.

Witnesses:

A. DOYDEY,  
W. T. BINGHAM.