



US00RE49056E

(19) **United States**
(12) **Reissued Patent**
Tal et al.

(10) **Patent Number:** **US RE49,056 E**
(45) **Date of Reissued Patent:** **May 3, 2022**

(54) **ACCESS DEVICE**

(71) Applicant: **Smiths Medical ASD, Inc.**, Plymouth, MN (US)

(72) Inventors: **Michael Tal**, Woodbridge, CT (US); **Janelle Anderson**, New York, NY (US); **Benjamin K. Yaffe**, San Francisco, CA (US); **William J. McCreight**, Harleysville, PA (US); **Robert Rabiner**, Tiverton, RI (US)

(73) Assignee: **SMITHS MEDICAL ASD, INC.**, Plymouth, MN (US)

(21) Appl. No.: **16/743,406**

(22) Filed: **Jan. 15, 2020**

Related U.S. Patent Documents

Reissue of:

(64) Patent No.: **8,377,006**
Issued: **Feb. 19, 2013**
Appl. No.: **13/084,440**
Filed: **Apr. 11, 2011**

U.S. Applications:

(63) Continuation of application No. 12/019,598, filed on Jan. 24, 2008, now Pat. No. 7,922,696.
(Continued)

(51) **Int. Cl.**
A61M 5/178 (2006.01)
A61M 25/06 (2006.01)
(Continued)

(52) **U.S. Cl.**
CPC **A61M 25/0606** (2013.01); **A61B 17/34** (2013.01); **A61B 17/3496** (2013.01); **A61M 25/0097** (2013.01); **A61B 2017/347** (2013.01)

(58) **Field of Classification Search**
CPC A61M 25/0097; A61M 25/0612; A61M 25/0631; A61M 25/01; A61M 25/0102; A61B 2017/347

See application file for complete search history.

(56) **References Cited**

U.S. PATENT DOCUMENTS

500,740 A 7/1893 Doyle
1,436,882 A 11/1922 Knepper
(Continued)

FOREIGN PATENT DOCUMENTS

DE 2052364 A1 4/1972
DE 8915299 U1 2/1990
(Continued)

OTHER PUBLICATIONS

U.S. Appl. No. 12/106,196, filed Apr. 18, 2008, now U.S. Pat. No. 8,105,286, issued on Jan. 31, 2012, by Janelle Anderson, et al., Notice of Allowance dated Sep. 28, 2011.

(Continued)

Primary Examiner — Catherine S Williams

(74) *Attorney, Agent, or Firm* — Benesch, Friedlander, Coplan & Aronoff LLP

(57) **ABSTRACT**

An access device places a medical article within a body space of a patient. The device has a needle section that includes an elongated body and a needle hub. The device further includes a dilator portion that has a dilator and a dilator hub. The dilator is coaxially disposed and slideable over the elongated body of the needle section. The device further includes a sheath section that has a sheath and a sheath hub. The sheath is coaxially disposed and slideable over the dilator. The device further includes a first locking mechanism operably disposed between the needle hub and the dilator hub to inhibit at least unintentional axial movement between the needle section and the dilator portion and a second locking mechanism operably disposed between the dilator hub and the sheath hub to inhibit at least unintentional axial movement between the dilator portion and the sheath section.

4 Claims, 23 Drawing Sheets

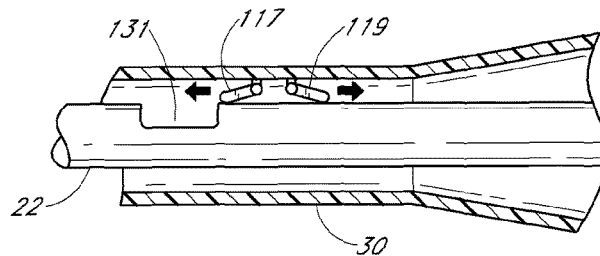
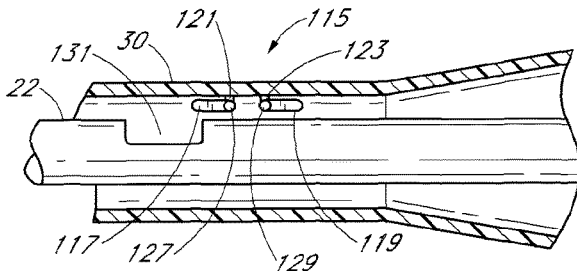

US RE49,056 E

Related U.S. Application Data					
		5,098,389	A	3/1992	Cappucci
(60)	Provisional application No. 60/886,443, filed on Jan. 24, 2007.	5,098,392	A *	3/1992	Fleischhacker et al. 604/164.05
		5,102,394	A	4/1992	Lasaitis et al.
		5,105,807	A	4/1992	Kahn et al.
(51)	Int. Cl.	5,108,374	A	4/1992	Lemieux
	<i>A61B 17/34</i> (2006.01)	5,112,308	A	5/1992	Olsen et al.
	<i>A61M 25/00</i> (2006.01)	5,114,401	A	5/1992	Stuart et al.
		5,124,544	A	6/1992	Ohzu
		5,135,502	A	8/1992	Koenig, Jr. et al.
(56)	References Cited	5,135,505	A	8/1992	Kaufman
	U.S. PATENT DOCUMENTS	5,158,544	A	10/1992	Weinstein
		5,167,637	A	12/1992	Okada et al.
		5,171,218	A	12/1992	Fonger et al.
		5,212,052	A	5/1993	Sakanoue et al.
		5,215,525	A	6/1993	Sturman
		5,215,528	A	6/1993	Purdy et al.
		5,242,410	A	9/1993	Melker
		5,242,414	A	9/1993	Fischell et al.
		5,242,427	A *	9/1993	Bilweis 604/264
		5,246,426	A	9/1993	Lewis et al.
		5,248,301	A	9/1993	Koenig, Jr. et al.
		5,248,306	A	9/1993	Clark et al.
		5,250,038	A	10/1993	Melker et al.
		5,255,691	A	10/1993	Otten
		5,279,590	A	1/1994	Sinko
		5,295,969	A	3/1994	Fischell
		5,295,970	A	3/1994	Clinton et al.
		5,306,253	A	4/1994	Brimhall
		5,312,355	A	5/1994	Lee
		5,312,359	A	5/1994	Wallace
		5,314,411	A	5/1994	Bierman et al.
		5,328,480	A	7/1994	Melker et al.
		5,330,433	A	7/1994	Fonger et al.
		5,334,149	A	8/1994	Nortman et al.
		5,334,157	A	8/1994	Klein et al.
		5,336,191	A	8/1994	Davis et al.
		5,342,315	A	8/1994	Rowe et al.
		5,366,441	A	11/1994	Crawford
		5,380,290	A	1/1995	Makower et al.
		5,388,589	A	2/1995	Davis
		5,391,152	A	2/1995	Patterson
		5,391,178	A	2/1995	Yapor
		5,397,311	A	3/1995	Walker et al.
		5,403,283	A	4/1995	Luther
		5,419,766	A	5/1995	Chang et al.
		5,424,410	A	6/1995	Payne et al.
		5,425,718	A	6/1995	Tay et al.
		5,468,024	A	11/1995	Carman et al.
		5,512,052	A	4/1996	Jesch
		5,520,654	A	5/1996	Wahlberg
		5,531,701	A	7/1996	Luther
		5,531,713	A	7/1996	Mastronardi et al.
		5,542,932	A	8/1996	Daugherty
		5,558,132	A	9/1996	Hauessler et al.
		5,562,634	A	10/1996	Flumene
		5,589,120	A	12/1996	Khan et al.
		5,676,653	A	10/1997	Taylor et al.
		5,676,658	A	10/1997	Erskine
		5,676,689	A	10/1997	Kensery et al.
		5,685,856	A	11/1997	Lehrer
		5,688,249	A	11/1997	Chang et al.
		5,688,570	A	11/1997	Ruttinger
		5,690,619	A	11/1997	Erskine
		5,704,914	A	1/1998	Stocking et al.
		5,712,229	A	1/1998	Hopkins et al.
		5,713,876	A	2/1998	Bogert et al.
		5,728,132	A	3/1998	Van Tassel et al.
		5,749,857	A	5/1998	Cuppy
		5,795,339	A	8/1998	Erskine
		5,810,780	A	9/1998	Brimhall et al.
		5,820,596	A	10/1998	Rosen et al.
		5,827,202	A	10/1998	Miraki et al.
		5,830,190	A	11/1998	Howell
		5,833,662	A	11/1998	Stevens
		5,853,393	A	12/1998	Bogert
		5,858,002	A	1/1999	Jesch
		5,865,806	A	2/1999	Howell
		5,885,217	A	3/1999	Gisselberg et al.

(56)		References Cited					
		U.S. PATENT DOCUMENTS					
5,885,253	A	3/1999	Liu	7,196,689	B2	3/2007	Moriyama
5,885,283	A	3/1999	Liu	7,226,434	B2	6/2007	Carlyon et al.
5,902,254	A	5/1999	Magram	7,270,649	B2	9/2007	Fitzgerald
5,904,657	A	5/1999	Unsworth et al.	7,455,660	B2	11/2008	Schweikert et al.
5,910,132	A	6/1999	Schultz	7,458,954	B2	12/2008	Ferguson et al.
5,911,705	A	6/1999	Howell	7,500,965	B2	3/2009	Menzi et al.
5,919,160	A	7/1999	Sanfilippo	7,503,596	B2	3/2009	Rome et al.
5,935,110	A	8/1999	Brimhall	7,556,617	B2	7/2009	Voorhees, Jr. et al.
5,954,698	A	9/1999	Pike	7,611,485	B2	11/2009	Ferguson
5,954,708	A	9/1999	Lopez et al.	7,614,123	B2	11/2009	Schweikert
5,957,894	A	9/1999	Kerwin et al.	7,618,395	B2	11/2009	Ferguson
5,984,895	A	11/1999	Padilla et al.	7,670,316	B2	3/2010	Windheuser et al.
6,004,294	A	12/1999	Brimhall et al.	7,682,339	B2*	3/2010	Fujii 604/164.08
6,027,480	A	2/2000	Davis et al.	7,722,567	B2	5/2010	Tal
6,046,143	A	4/2000	Khan et al.	7,827,656	B2	11/2010	Schweikert
6,074,377	A	6/2000	Sanfilippo	7,833,202	B2	11/2010	Suzuki
6,080,137	A	6/2000	Pike	7,922,696	B2	4/2011	Tal et al.
6,080,141	A	6/2000	Castro et al.	8,021,338	B2	9/2011	Adams
6,117,108	A	9/2000	Woehr et al.	8,070,750	B2	12/2011	Wenstrom, Jr. et al.
6,117,140	A	9/2000	Munsinger	8,105,286	B2	1/2012	Anderson et al.
6,120,460	A	9/2000	Abreu	8,192,402	B2	6/2012	Anderson et al.
6,120,494	A	9/2000	Jonkman	8,202,251	B2	6/2012	Bierman et al.
6,137,468	A	10/2000	Martinez et al.	8,211,087	B2	7/2012	Carter et al.
6,156,010	A	12/2000	Kuracina et al.	8,377,006	B2	2/2013	Tal et al.
6,159,179	A	12/2000	Simonson	8,545,533	B2	10/2013	Spenser et al.
6,179,813	B1	1/2001	Ballow et al.	8,628,497	B2	1/2014	Finnestad et al.
6,179,823	B1	1/2001	Niedospial, Jr.	8,657,790	B2	2/2014	Tal et al.
6,210,332	B1	4/2001	Chiao et al.	8,672,888	B2	3/2014	Tal
6,210,366	B1	4/2001	Sanfilippo	8,721,546	B2	5/2014	Belson
6,245,044	B1	6/2001	Daw et al.	8,728,035	B2	5/2014	Warring et al.
6,273,871	B1	8/2001	Davis et al.	8,900,192	B2	12/2014	Anderson et al.
6,277,100	B1	8/2001	Raulerson	8,915,884	B2	12/2014	Tal et al.
6,287,278	B1	9/2001	Woehr et al.	8,956,327	B2	2/2015	Bierman et al.
6,287,322	B1	9/2001	Zhu et al.	8,986,227	B2	3/2015	Belson
6,328,717	B1	12/2001	Solomon et al.	9,162,037	B2	10/2015	Belson et al.
6,336,914	B1*	1/2002	Gillespie, III 604/165.01	9,375,553	B2	6/2016	Chrisman
6,379,333	B1	4/2002	Brimhall et al.	9,402,979	B2	8/2016	Alokaili et al.
6,436,070	B1	8/2002	Botich et al.	9,675,784	B2	6/2017	Belson
6,461,362	B1	10/2002	Halseth et al.	9,757,540	B2	9/2017	Belson
6,475,207	B1	11/2002	Maginot	9,764,117	B2	9/2017	Bierman
6,488,662	B2	12/2002	Sirimanne	10,086,171	B2	10/2018	Belson
6,500,152	B1	12/2002	Illi	10,136,916	B2	11/2018	Bierman et al.
6,524,277	B1*	2/2003	Chang 604/164.02	10,220,191	B2	3/2019	Belson et al.
6,567,101	B1	5/2003	Thomas	10,441,752	B2	10/2019	Bierman et al.
6,589,262	B1	7/2003	Honebrink et al.	2002/0010436	A1	1/2002	Becker et al.
6,595,955	B2	7/2003	Ferguson et al.	2002/0072712	A1	6/2002	Nool et al.
6,602,240	B2	8/2003	Hermann et al.	2002/0087076	A1	7/2002	Meguro et al.
6,607,353	B2	8/2003	Masutani	2003/0032927	A1	2/2003	Halseth et al.
6,607,511	B2	8/2003	Halseth et al.	2003/0060842	A1	3/2003	Chin et al.
6,626,868	B1	9/2003	Prestidge et al.	2003/0088212	A1	5/2003	Tal
6,641,564	B1	11/2003	Kraus	2003/0153874	A1*	8/2003	Tal 604/164.1
6,692,462	B2	2/2004	Mackenzie et al.	2003/0171718	A1*	9/2003	DeLegge et al. 604/164.01
6,692,482	B2	2/2004	Heller et al.	2003/0199827	A1	10/2003	Thorne
6,695,816	B2	2/2004	Cassidy	2003/0216771	A1	11/2003	Osyпка et al.
6,714,809	B2	3/2004	Lee et al.	2004/0008191	A1	1/2004	Poupyrev et al.
6,719,772	B2	4/2004	Trask et al.	2004/0034383	A1	2/2004	Belson
6,726,659	B1*	4/2004	Stocking et al. 604/164.09	2004/0092879	A1	5/2004	Kraus et al.
6,749,588	B1	6/2004	Howell et al.	2004/0102789	A1	5/2004	Baughman
6,786,875	B2	9/2004	Barker et al.	2004/0167439	A1	8/2004	Sharrow
6,796,962	B2	9/2004	Ferguson et al.	2004/0171988	A1	9/2004	Moretti
6,808,520	B1	10/2004	Fourkas et al.	2004/0193112	A1	9/2004	Glazier et al.
6,836,687	B2	12/2004	Kelley	2004/0199197	A1	10/2004	Eidenschink et al.
6,902,546	B2	6/2005	Ferguson	2004/0220499	A1	11/2004	Griego et al.
6,905,481	B2	6/2005	Sirimanne	2004/0239687	A1	12/2004	Idesawa et al.
6,940,092	B2	9/2005	Yoshida et al.	2005/0027263	A1	2/2005	Woehr et al.
6,972,002	B2	12/2005	Thorne	2005/0090835	A1	4/2005	Deal et al.
6,994,693	B2	2/2006	Tal	2005/0113798	A1	5/2005	Slater et al.
7,001,396	B2	2/2006	Glazier et al.	2005/0143770	A1	6/2005	Carter et al.
7,004,927	B2	2/2006	Ferguson et al.	2005/0245875	A1	11/2005	Restelli et al.
7,025,746	B2	4/2006	Tal	2006/0015071	A1	1/2006	Fitzgerald
7,109,967	B2	9/2006	Hioki et al.	2006/0129100	A1	6/2006	Tal
7,125,396	B2	10/2006	Leinsing et al.	2006/0178635	A1	8/2006	Callaway
7,179,244	B2	2/2007	Smith et al.	2006/0274036	A1	12/2006	Hoiki et al.
7,182,755	B2	2/2007	Tal	2007/0021685	A1	1/2007	Oepen et al.
7,192,433	B2	3/2007	Osyпка et al.	2007/0060889	A1	3/2007	Adams
				2007/0161908	A1	7/2007	Goldman et al.
				2007/0270751	A1	11/2007	Stangenes et al.
				2007/0282300	A1	12/2007	Attawia et al.
				2008/0262430	A1	10/2008	Anderson et al.

(56)

References Cited

U.S. PATENT DOCUMENTS

2008/0262431 A1 10/2008 Anderson et al.
 2008/0294111 A1 11/2008 Tal et al.
 2009/0149857 A1 6/2009 Culbert et al.
 2009/0163861 A1 6/2009 Carlyon
 2009/0221961 A1 9/2009 Tal et al.
 2009/0264867 A1 10/2009 Schweikert et al.
 2010/0010441 A1 1/2010 Belson
 2010/0069880 A1 3/2010 Grayzel et al.
 2010/0191189 A1 7/2010 Harding et al.
 2010/0256567 A1 10/2010 Smith
 2011/0009827 A1 1/2011 Bierman et al.
 2011/0021994 A1 1/2011 Anderson et al.
 2011/0046564 A1 2/2011 Zhong
 2011/0202006 A1 8/2011 Bierman et al.
 2011/0218496 A1 9/2011 Bierman
 2011/0270192 A1 11/2011 Anderson et al.
 2011/0276002 A1 11/2011 Bierman
 2012/0004665 A1 1/2012 Defossez et al.
 2012/0041371 A1 2/2012 Tal et al.
 2012/0065590 A1 3/2012 Bierman et al.
 2012/0130307 A1 5/2012 Pobitschka
 2012/0283640 A1 11/2012 Bierman et al.
 2012/0316500 A1 12/2012 Bierman et al.
 2013/0123704 A1 5/2013 Bierman et al.
 2014/0025036 A1 1/2014 Bierman et al.
 2014/0081210 A1 3/2014 Bierman et al.
 2015/0190168 A1 7/2015 Bierman et al.
 2015/0297868 A1 10/2015 Tal et al.
 2015/0351793 A1 12/2015 Bierman et al.
 2017/0291009 A1 10/2017 Sos
 2018/0001060 A1 1/2018 Bierman et al.
 2018/0296804 A1 10/2018 Bierman
 2019/0076166 A1 3/2019 Bierman

FOREIGN PATENT DOCUMENTS

DE 8914941 U1 9/1990
 DE 20211804 U1 1/2003
 EP 0139091 7/1984
 EP 0129745 A2 1/1985
 EP 0139091 A1 5/1985
 EP 0161636 11/1985
 EP 0161636 A2 11/1985
 EP 0352928 A1 1/1990
 EP 0411605 A1 2/1991
 EP 0583144 A1 2/1994
 EP 0502714 11/1995
 EP 0502714 B1 11/1995
 EP 0730880 A1 9/1996
 EP 734739 A2 10/1996
 EP 0745409 A1 12/1996
 EP 0750916 A2 1/1997
 EP 0806221 A2 11/1997
 EP 1570793 A2 9/2005
 EP 1458437 B1 3/2010
 FR 2368968 A1 5/1978
 JP 53-51692 5/1978
 JP 06285172 A 10/1994
 JP 07148270 A 6/1995
 JP 08336593 A 12/1996
 JP 11299897 A 11/1999
 JP 2001190682 A 7/2001
 JP 2003512903 A 4/2003
 JP 2003154013 A 5/2003
 JP 2003265615 A 9/2003
 JP 2004500218 A 1/2004
 JP 2004097843 A 4/2004
 JP 2005514114 A 5/2005
 JP 07-503172 2/2007
 JP 2007503172 A 2/2007
 JP 2007209721 A 8/2007
 JP 2010504295 A 2/2010
 JP 2010510039 A 4/2010
 JP 2016163667 A 9/2016
 KR 20050027359 3/2005

KR 20050027359 A 3/2005
 WO 83/01575 5/1983
 WO WO-8301575 A1 5/1983
 WO WO-8807388 A1 10/1988
 WO WO-9218193 A1 10/1992
 WO WO-9311812 A1 6/1993
 WO WO-9312826 A1 7/1993
 WO WO-9412233 A1 6/1994
 WO WO-1997005912 A2 2/1997
 WO WO-9804189 A1 2/1998
 WO WO-98024494 A1 6/1998
 WO WO-9857685 A1 12/1998
 WO WO-0000104 A1 1/2000
 WO WO-2001/23028 A1 4/2001
 WO WO-01024865 A1 4/2001
 WO WO-01041860 A1 6/2001
 WO WO-0178595 A1 10/2001
 WO WO-2002/41932 A2 5/2002
 WO WO-0236179 A2 5/2002
 WO WO-2003/057272 A2 7/2003
 WO WO-06119503 A1 11/2006
 WO WO 2007/046850 4/2007
 WO WO-2007046850 A2 4/2007
 WO WO-08064332 A2 5/2008
 WO WO 2008/131289 10/2008
 WO WO-2008131289 A2 10/2008
 WO WO-2010048449 A2 4/2010
 WO WO-2010056906 A2 5/2010
 WO WO-2010083467 A2 7/2010
 WO WO 2010/132608 11/2010
 WO WO-2010132608 A2 11/2010
 WO WO-2012135761 A1 10/2012
 WO WO-2012162677 A1 11/2012
 WO WO-2013026045 A1 2/2013
 WO WO-13067518 A1 5/2013

OTHER PUBLICATIONS

U.S. Appl. No. 14/524,978, filed Oct. 27, 2014, by Steven F. Bierman, et al.
 U.S. Appl. No. 14/543,576, filed Nov. 17, 2014, now U.S. Pat. No. 9,764,117, issued on Sep. 19, 2017, by Steven F. Bierman, et al., Office Action dated Sep. 16, 2016; and Notice of Allowance dated May 15, 2017.
 U.S. Appl. No. 15/703,026, filed Sep. 13, 2017, now U.S. Pat. No. 10,441,752, issued on Oct. 15, 2019, by Steven F. Bierman, et al., Notice of Allowance dated Aug. 6, 2019.
 U.S. Appl. No. 13/185,358, filed Jul. 18, 2011, now U.S. Pat. No. 8,900,192, issued on Dec. 2, 2014, by Janelle Anderson, et al., Office Actions dated Jan. 7, 2013, Jun. 6, 2013, Nov. 26, 2013 and Apr. 14, 2014; and Notice of Allowance dated Jul. 28, 2014.
 U.S. Appl. No. 12/106,119, filed Apr. 18, 2008, now U.S. Pat. No. 8,192,402, issued on Jun. 5, 2012, by Janelle Anderson, et al., Office Action dated Sep. 15, 2011; and Notice of Allowance dated Feb. 8, 2012.
 U.S. Appl. No. 13/466,933, filed May 8, 2012, by Janelle Anderson, et al.
 U.S. Appl. No. 12/019,598, filed Jan. 24, 2008, now U.S. Pat. No. 7,922,696, issued on Apr. 12, 2011, by Michael Tal, et al., Office Action dated Jun. 25, 2009; and Notices of Allowance dated Apr. 16, 2010, Sep. 27, 2010, and Jan. 24, 2011.
 U.S. Appl. No. 13/084,440, filed Apr. 11, 2011, now U.S. Pat. No. 8,377,006, issued on Feb. 19, 2013, by Michael Tal, et al., Office Action dated Dec. 21, 2011; and Notice of Allowance dated Oct. 15, 2012.
 U.S. Appl. No. 13/747,335, filed Jan. 22, 2013, now U.S. Pat. No. 8,915,884, issued on Dec. 23, 2014, by Michael Tal, et al., Office Action dated Oct. 25, 2013; and Notices of Allowance dated Mar. 3, 2014 and Jul. 23, 2014.
 U.S. Appl. No. 14/578,085, filed Dec. 19, 2014, by Michael Tal, et al., Office Actions dated Sep. 1, 2016 and Jul. 10, 2017.
 U.S. Appl. No. 16/246,489, filed Jan. 12, 2019, by Steven F. Bierman, et al.
 U.S. Appl. No. 16/246,490, filed Jan. 12, 2019, by Steven F. Bierman, et al.

(56)

References Cited

OTHER PUBLICATIONS

U.S. Appl. No. 16/738,316, filed Jan. 9, 2020, by Michael Tal, et al., Office Action dated Feb. 18, 2020.
U.S. Appl. No. 16/738,310, filed Jan. 9, 2020, by Michael Tal, et al., Office Action dated Feb. 18, 2020.
Examination Report for European Application No. 02806219.8-2310 dated May 16, 2008.
Examination Report for European Application No. 02806219.8-2310 dated Sep. 18, 2007.
International Search Report for PCT Application No. PCT/US/2002/041371, dated Oct. 2, 2003.
International Search Report for PCT Application No. PCT/US/2006/011624, dated Oct. 17, 2007.
International Search Report for PCT Application No. PCT/US/2008/051950, dated Oct. 22, 2008.
International Search Report PCT-US2009-037198 dated Jun. 15, 2009.
Results of Partial International Search for PCT Application No. PCT/US/2008/060914, dated Oct. 29, 2008.
Results of Partial International Search for PCT Application No. PCT/US/2008/060930, dated Oct. 29, 2008.
A photograph of various access devices, Jul. 20, 2011.
A photograph of various access devices, Mar. 1, 2007.
International Search Report and Written Opinion in Application No. PCT/US2019/019640 dated Jun. 5, 2019 30 pages.
Office Action from EP 08746350.1-2310 dated Jun. 17, 2011.

Office Action in EP 08746365.9-2310 dated Jul. 12, 2011.
Photograph of various access devices.
Photos of a peripheral emergency infusion device Applicant believes to be produced by Arrow International Inc.
Photos of a peripheral emergency infusion device Applicant believes to be produced by Arrow International Inc., Jul. 20, 2011.
Photos of a splittable catheter design.
Photos of a splittable catheter design, Jul. 20, 2011.
Photos of an infusion device Applicant believes to be produced by B. Braun Medical Inc.
Photos of an infusion device Applicant believes to be produced by B. Braun Medical Inc., Jul. 20, 2011.
Photos of an infusion device Applicant believes to be produced by B. Braun Medical Inc., Mar. 1, 2007.
Results of Preliminary Report of PCT/US2008/060930, filed on Apr. 18, 2008, mailed on Oct. 29, 2009.
Results of Preliminary Report of PCT/US2008/060914 filed Apr. 18, 2008, mailed Oct. 20, 2009.
U.S. Department of Health and Human Services, "Medical Devices with Sharps Injury Prevention Features," Guidance for Industry and FDA Staff in 20 pages. Issued on Aug. 9, 2005.
A photograph of various access devices.
Arrow Trauma Products No. TRM-C 12/00 11M, Arrow International, dated 2000.

* cited by examiner

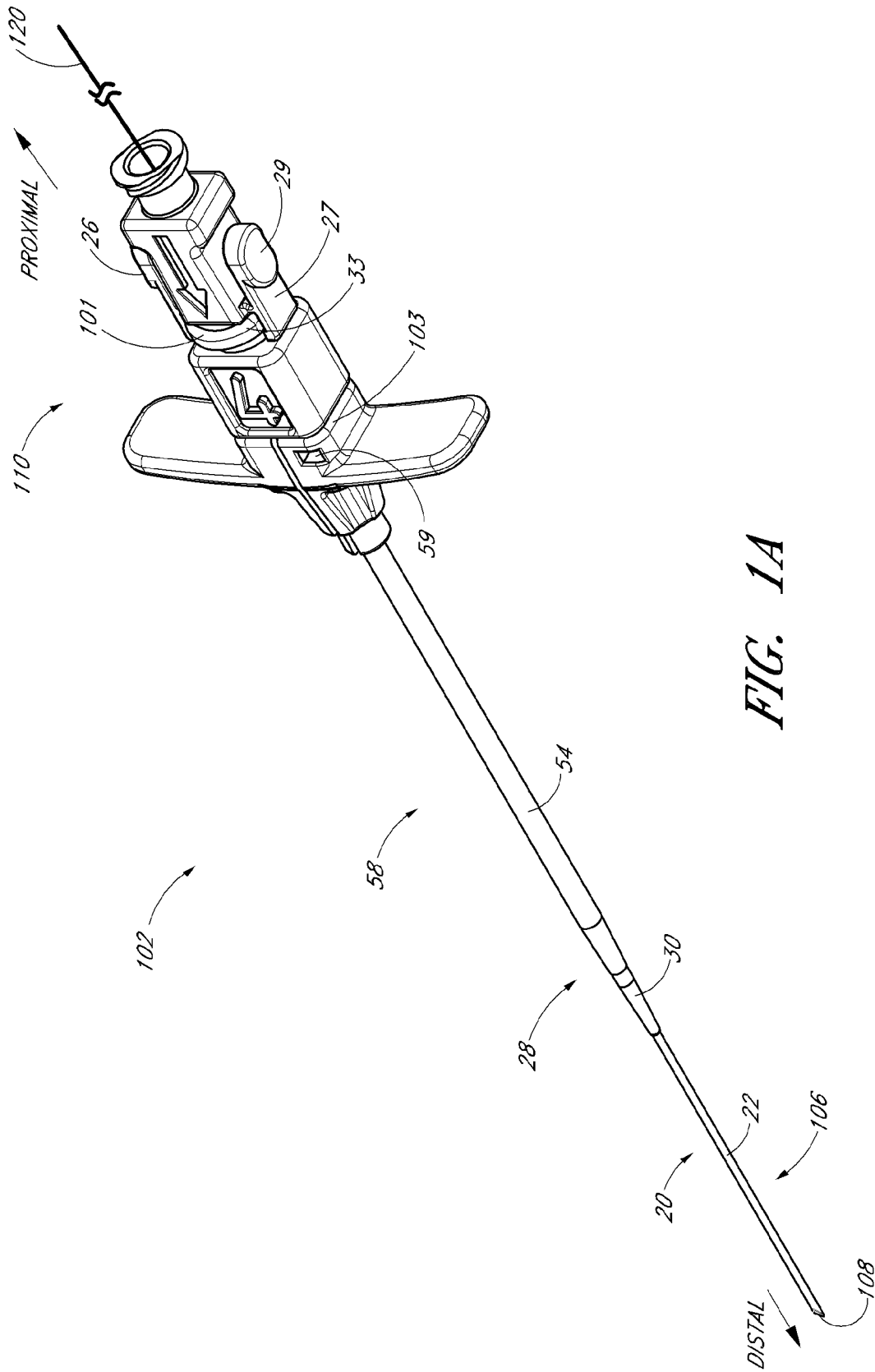

FIG. 1A

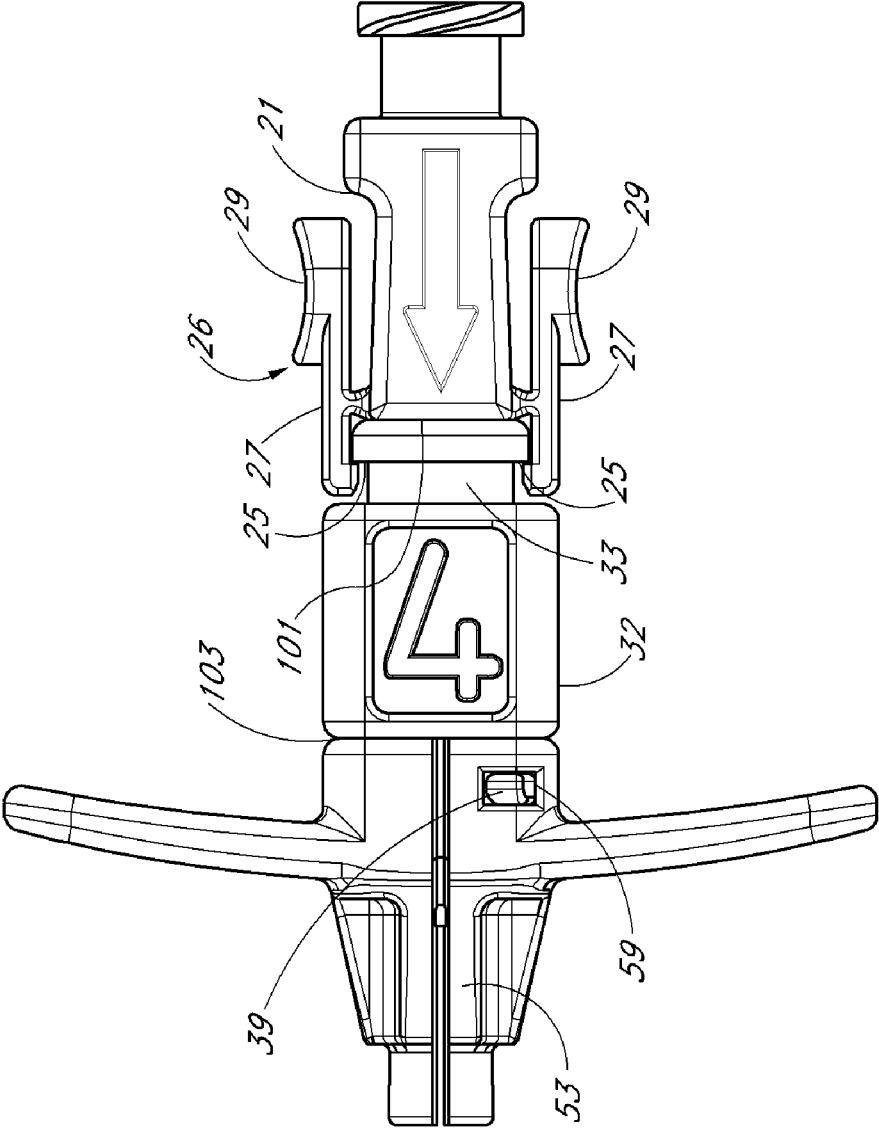

FIG. 1B

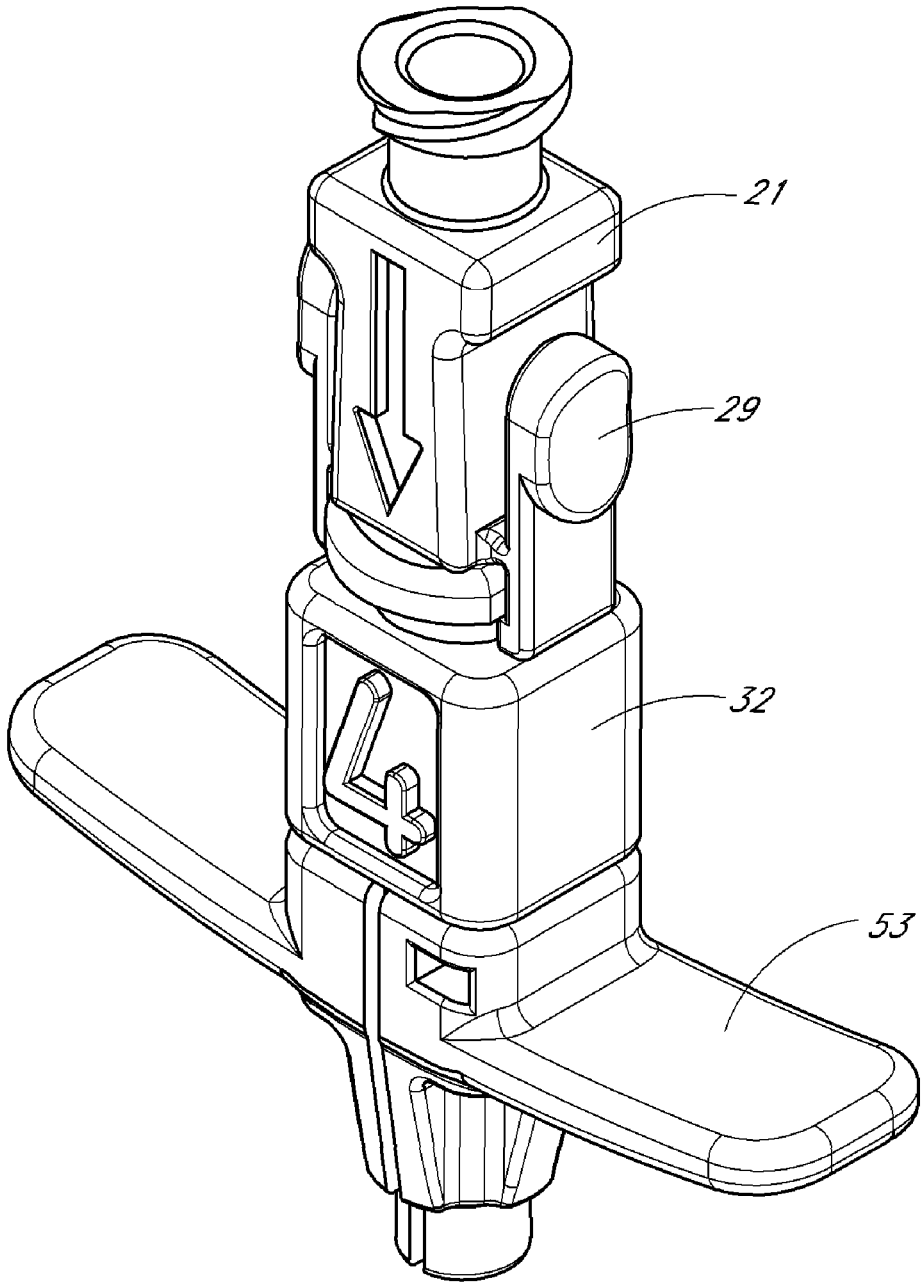

FIG. 1C

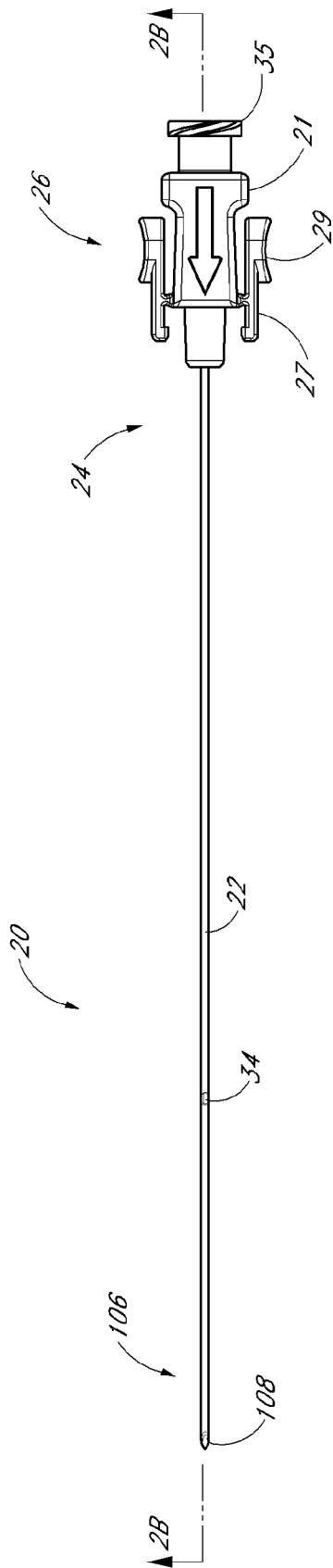

FIG. 2A

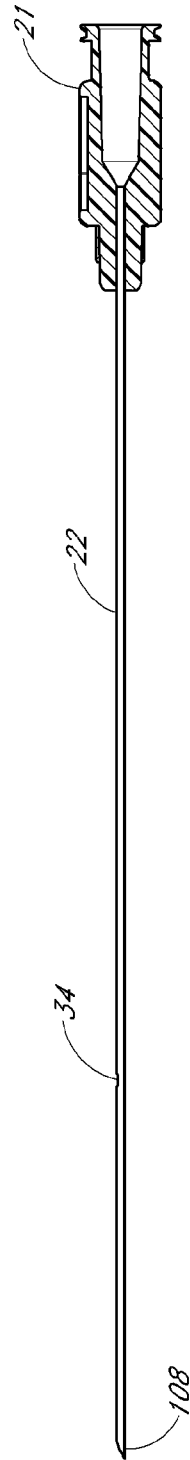

FIG. 2B

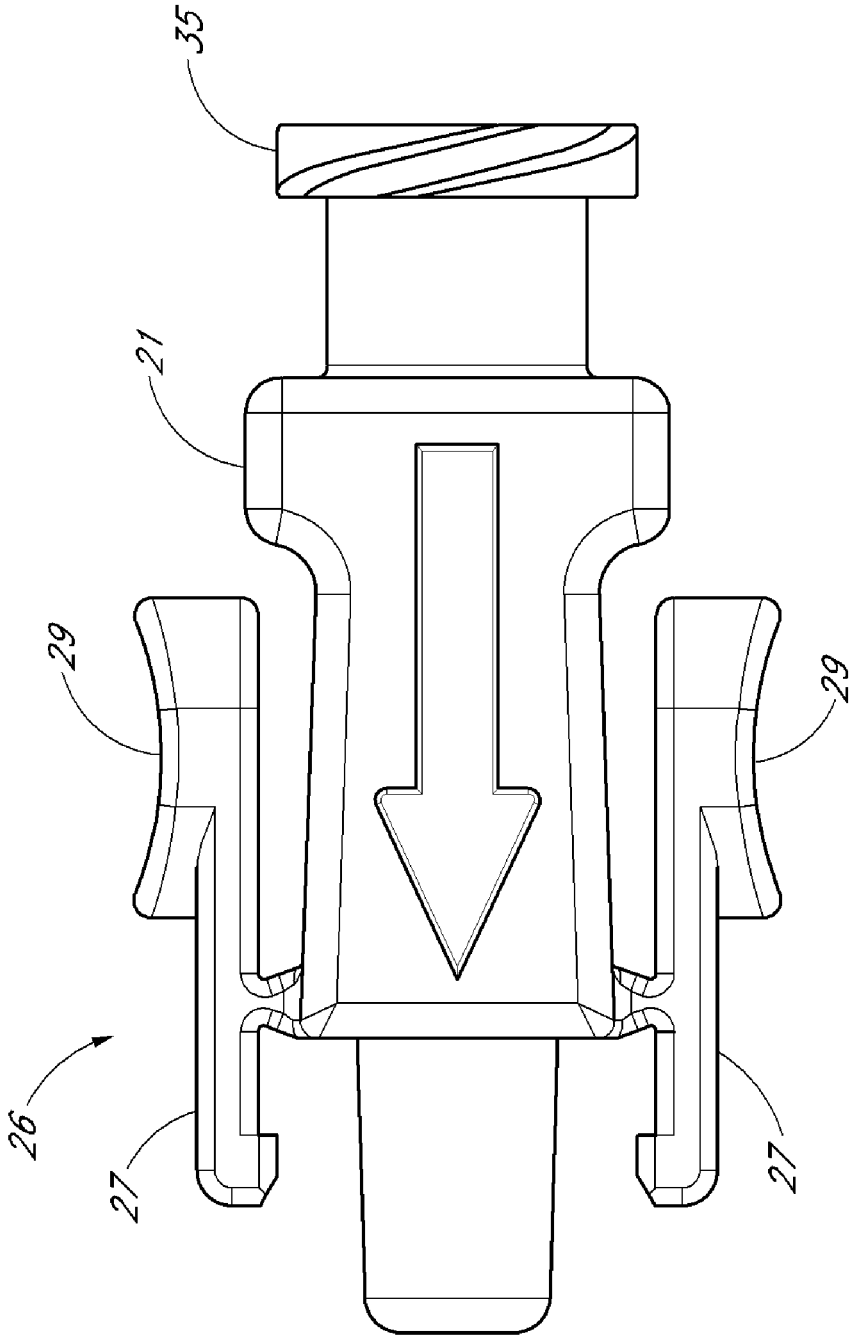
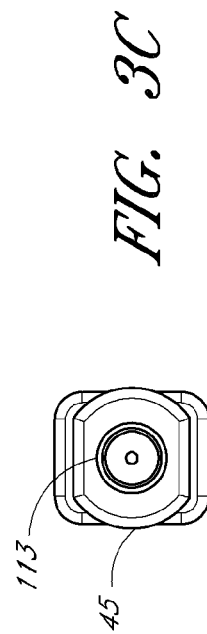
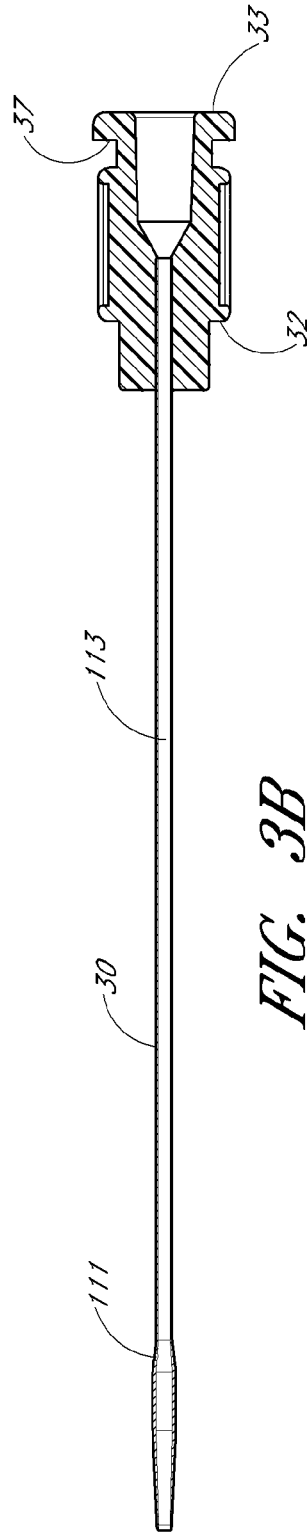
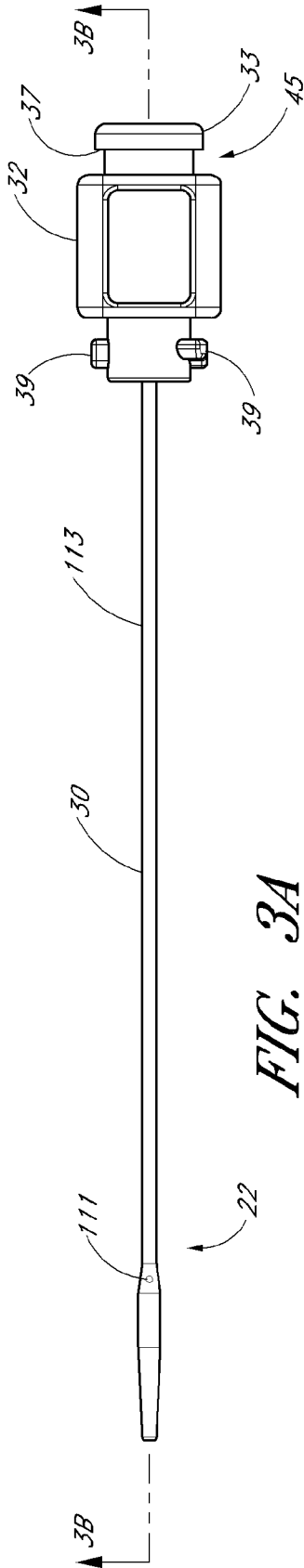

FIG. 2C



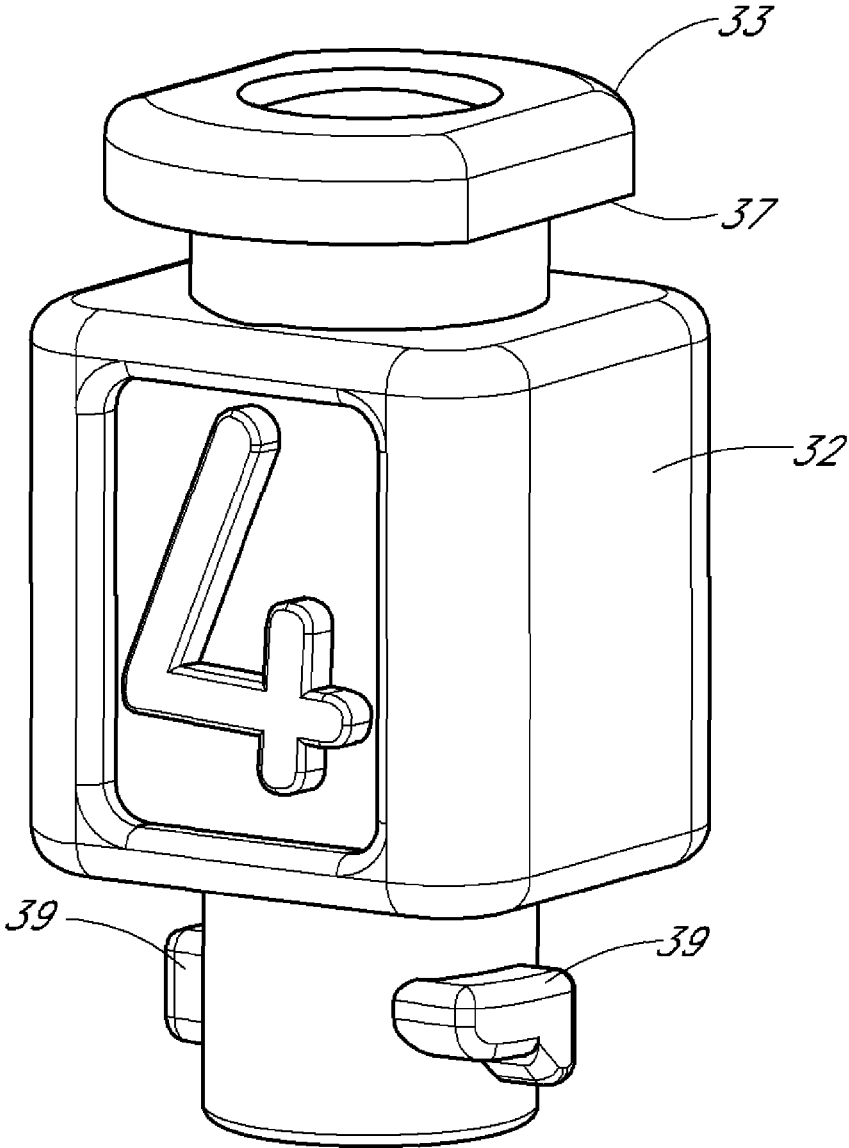
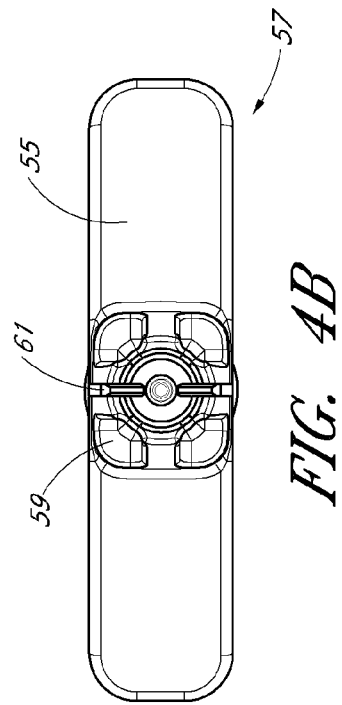
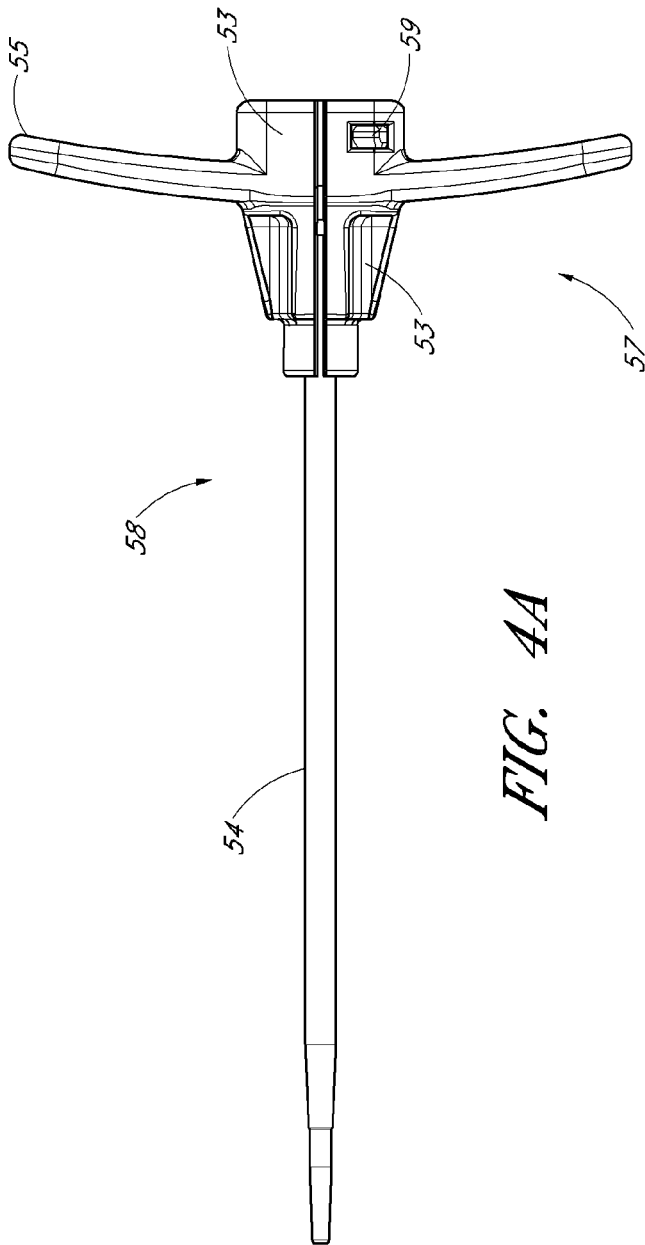

FIG. 3D



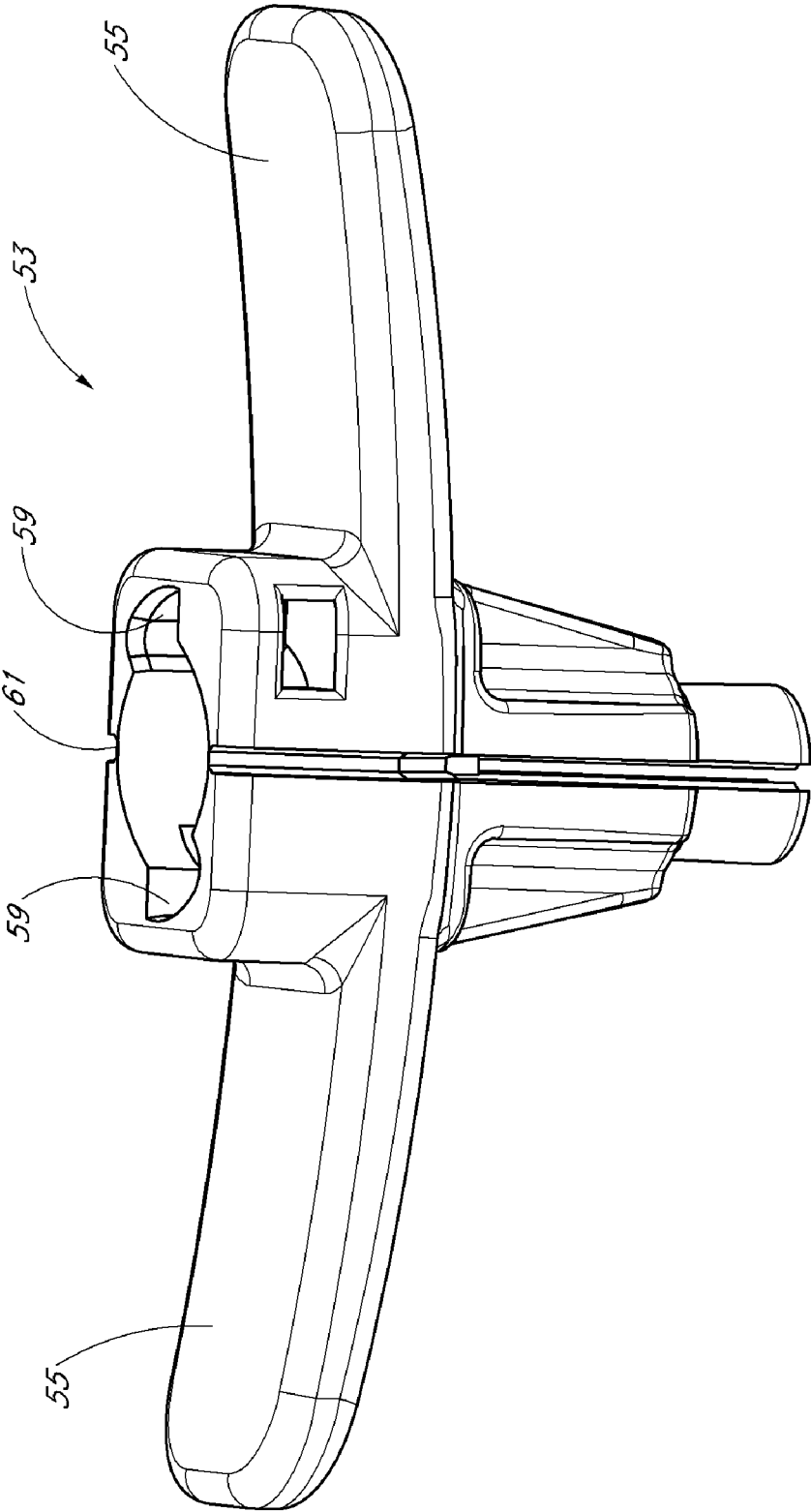

FIG. 4C

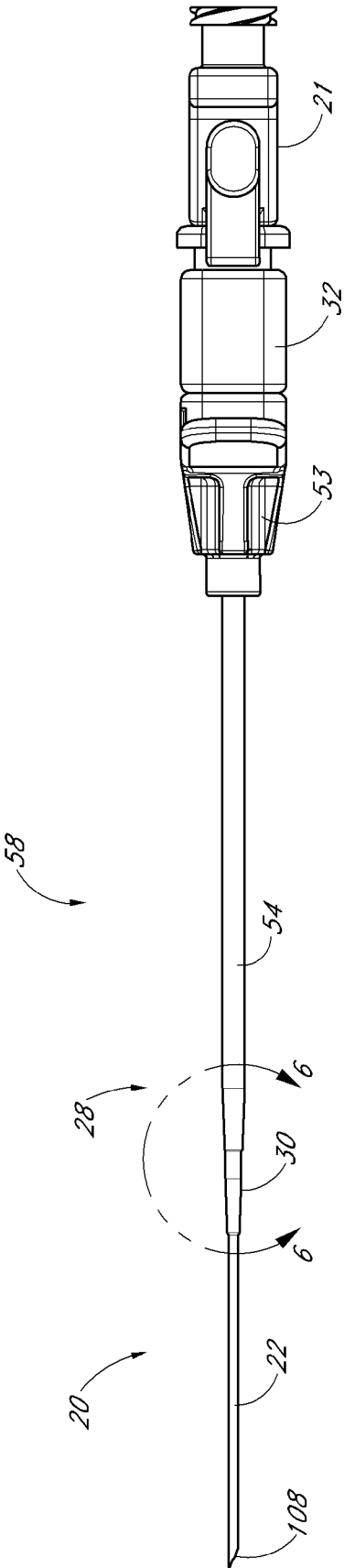

FIG. 5

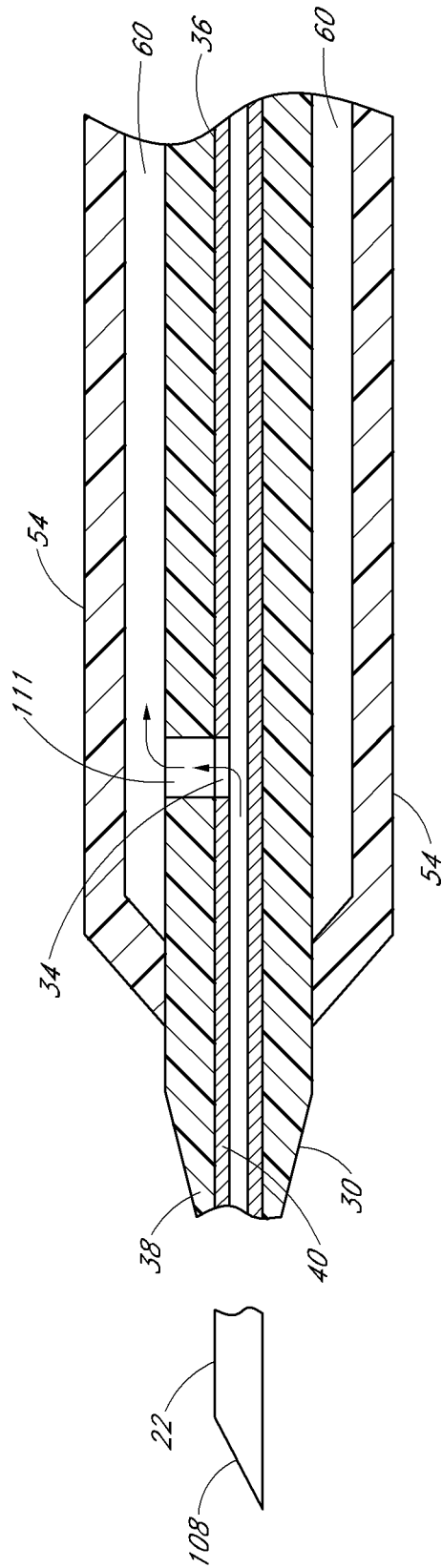

FIG. 6

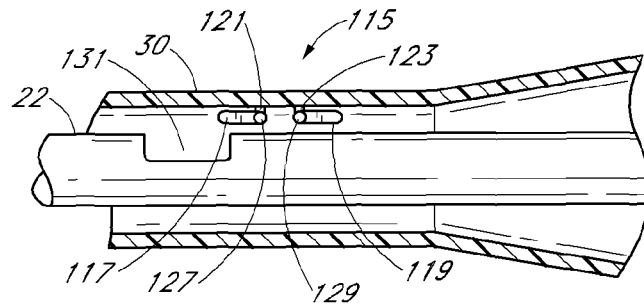

FIG. 7A

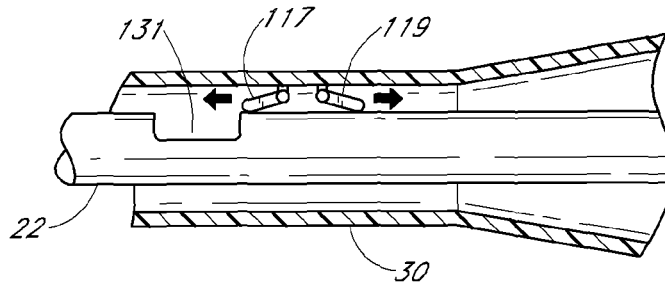

FIG. 7B

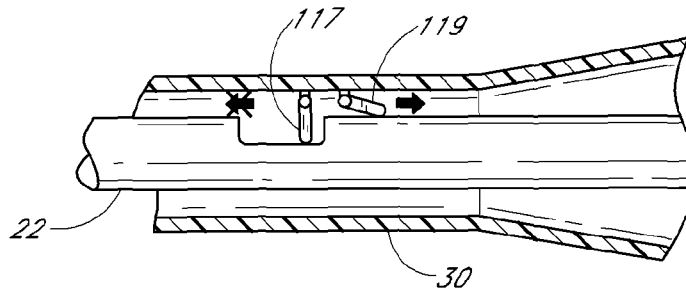

FIG. 7C

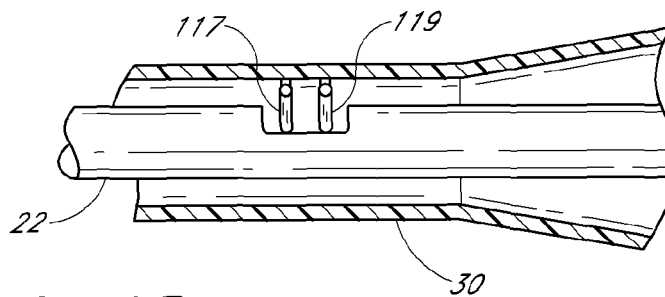

FIG. 7D

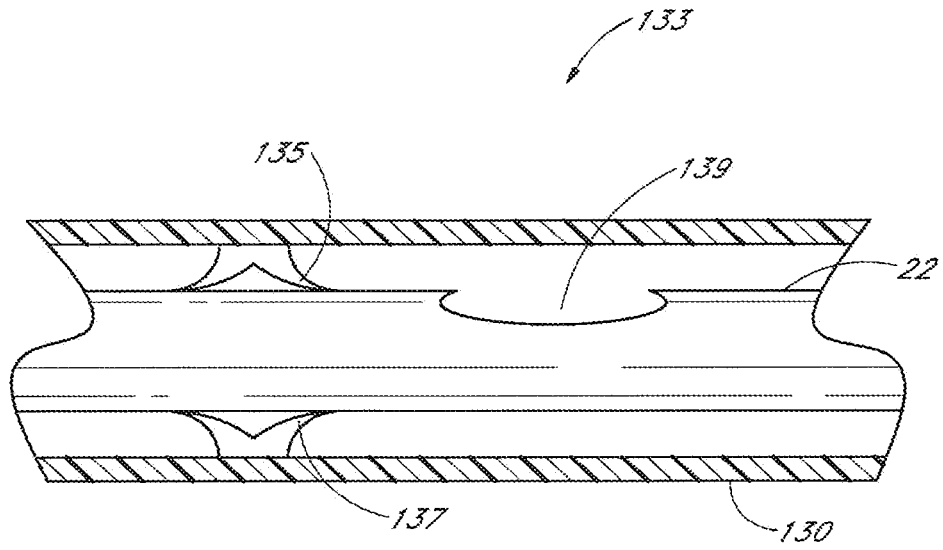

FIG. 8A
"Amended"

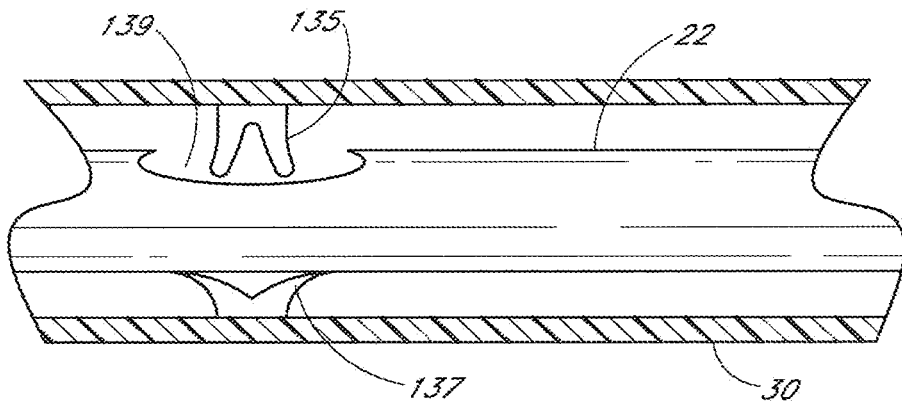

FIG. 8B

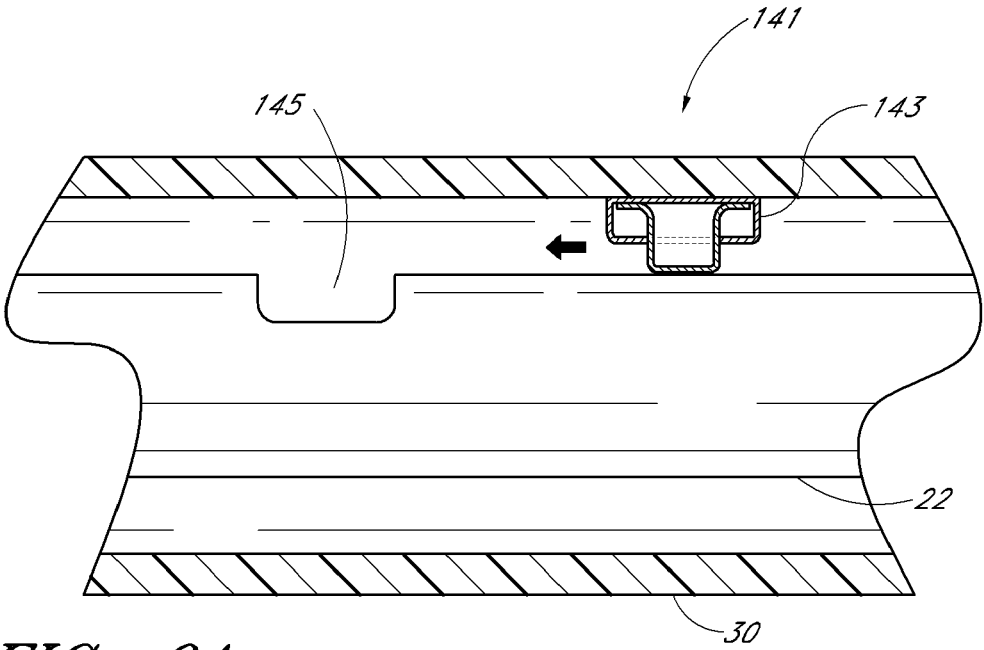

FIG. 9A

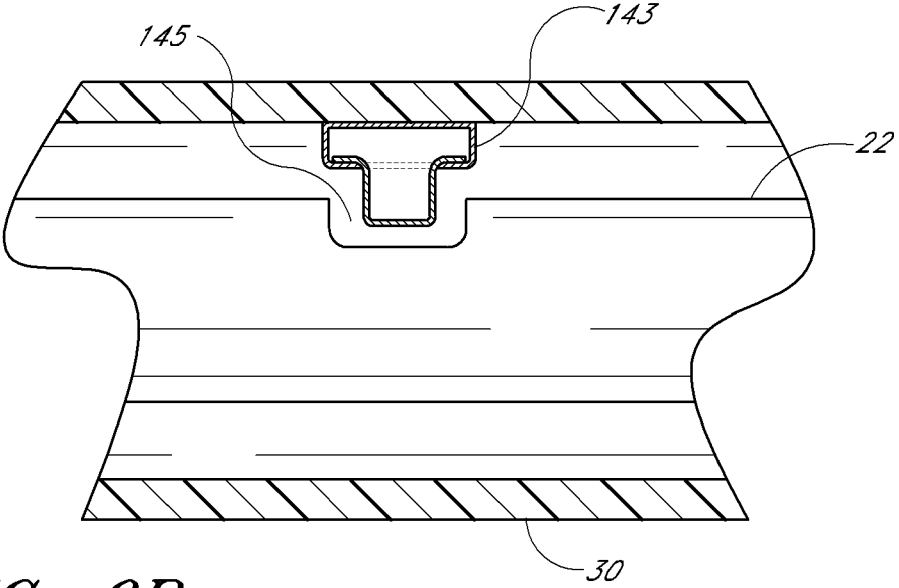

FIG. 9B

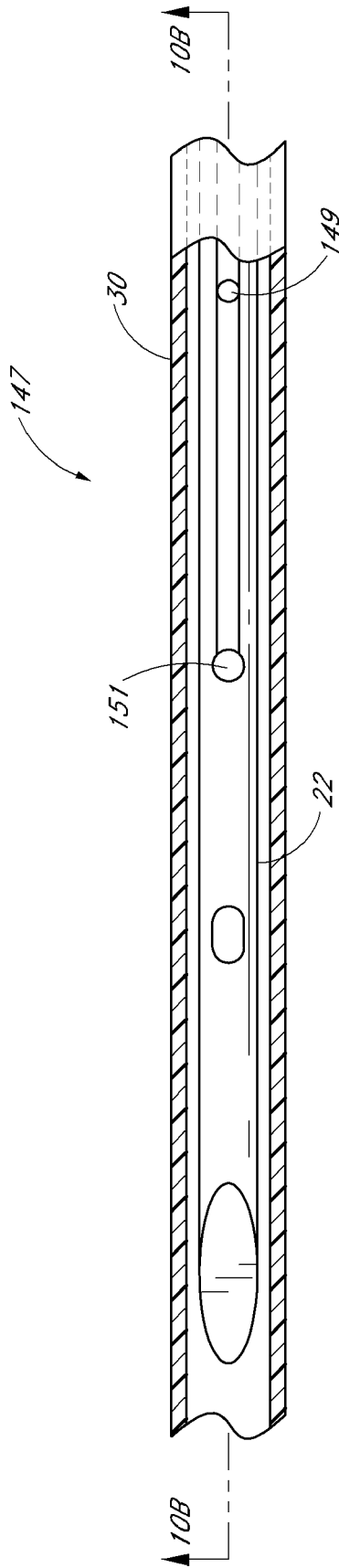

FIG. 10A

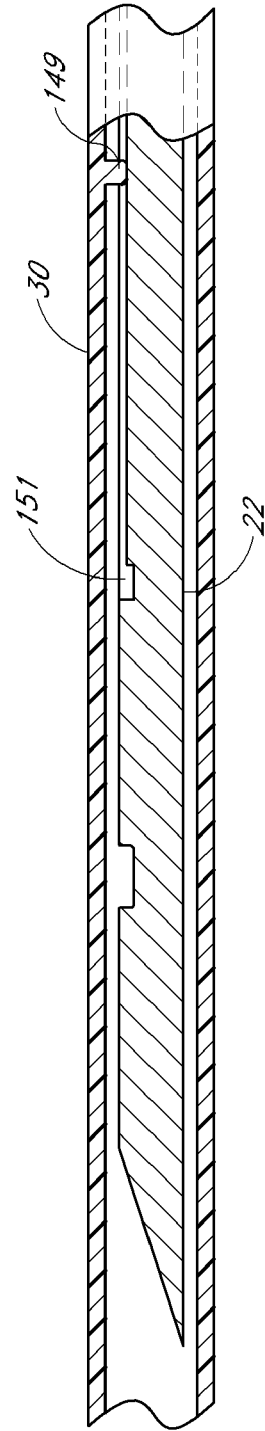

FIG. 10B

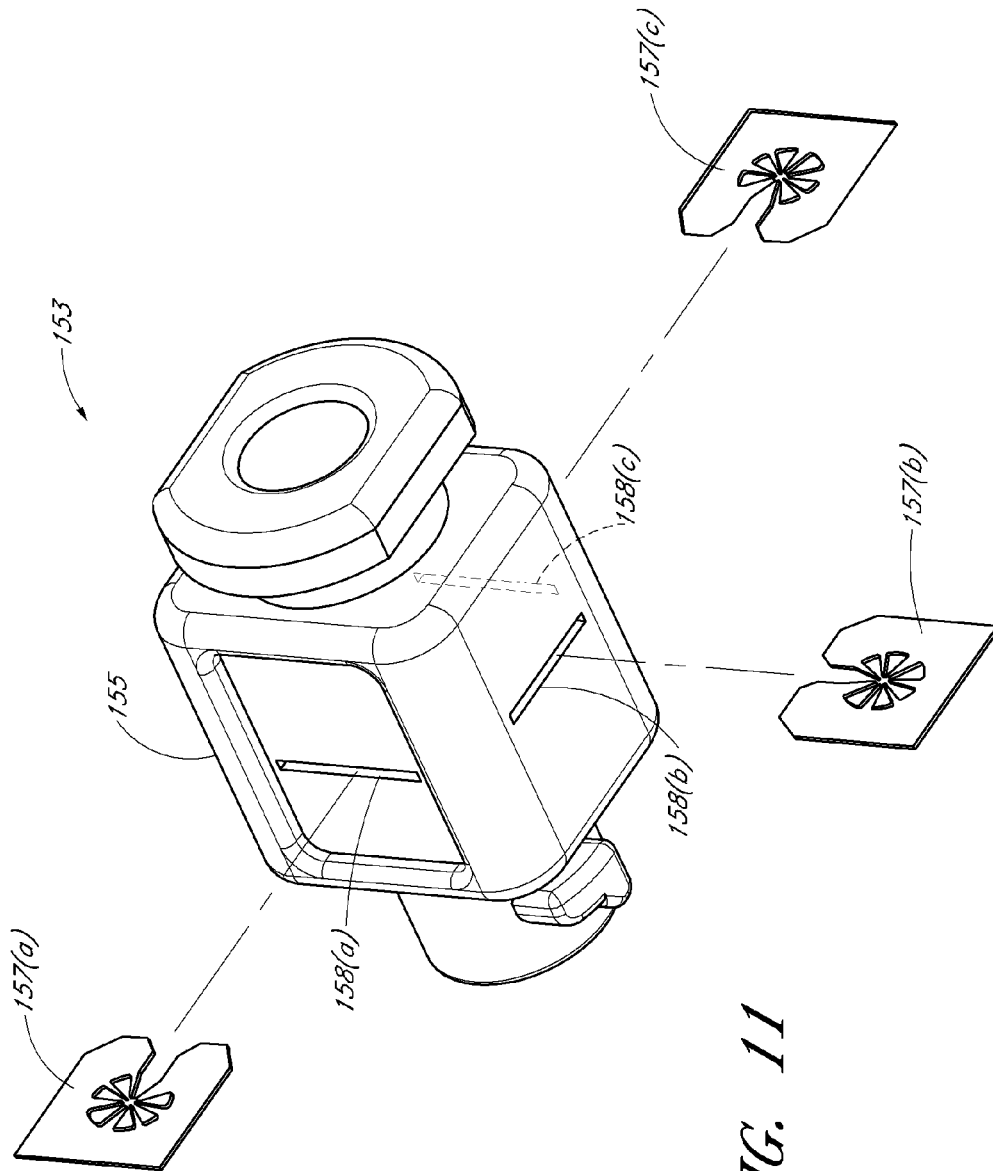

FIG. 11

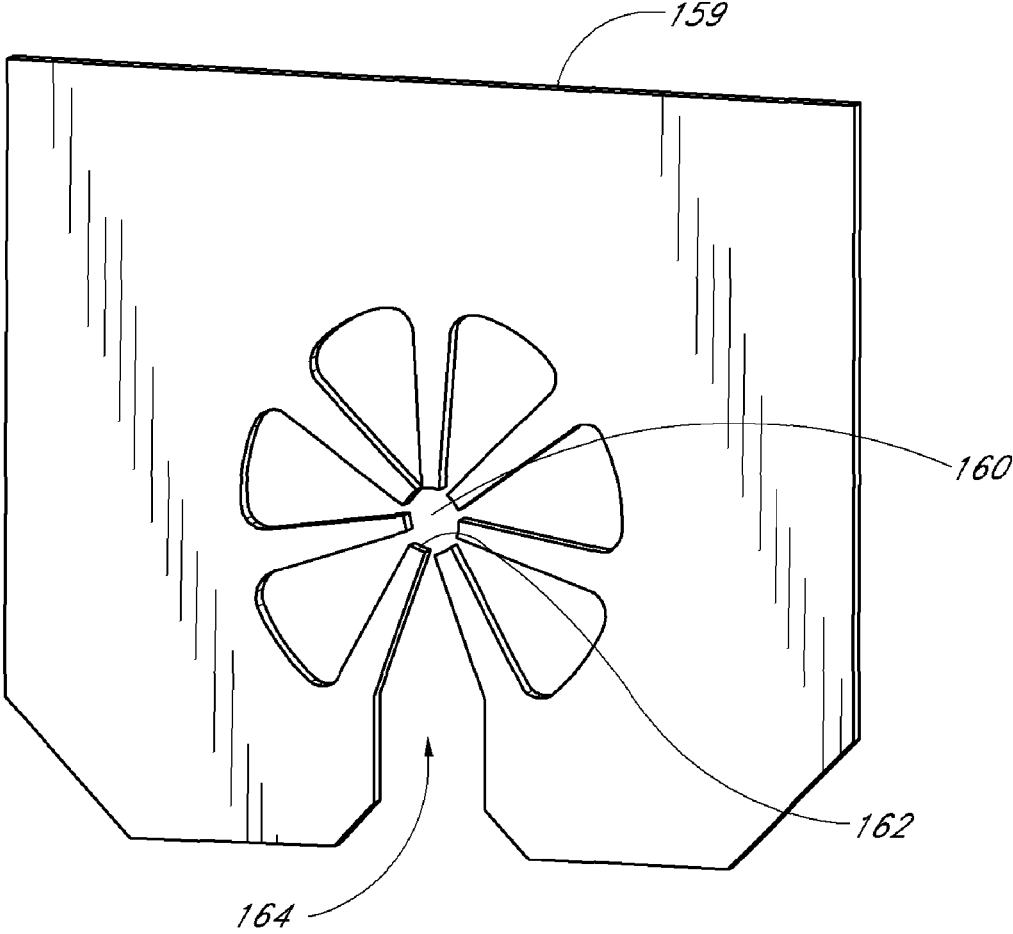

FIG. 12A

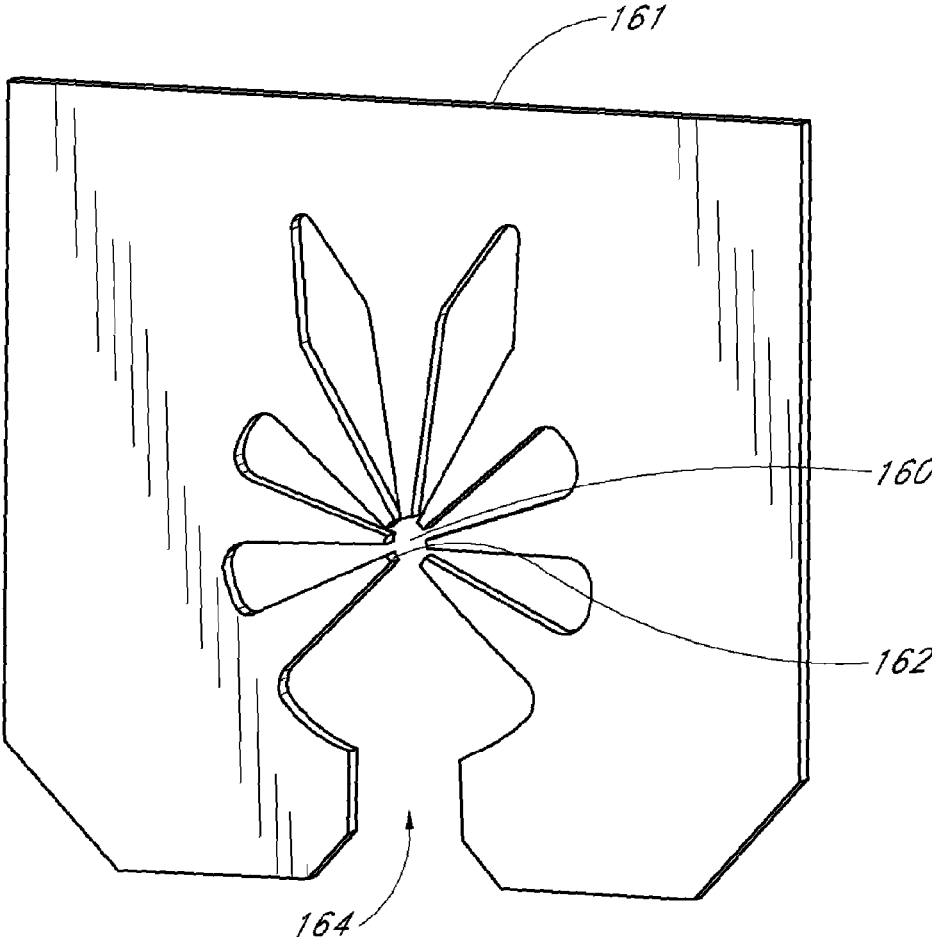

FIG. 12B

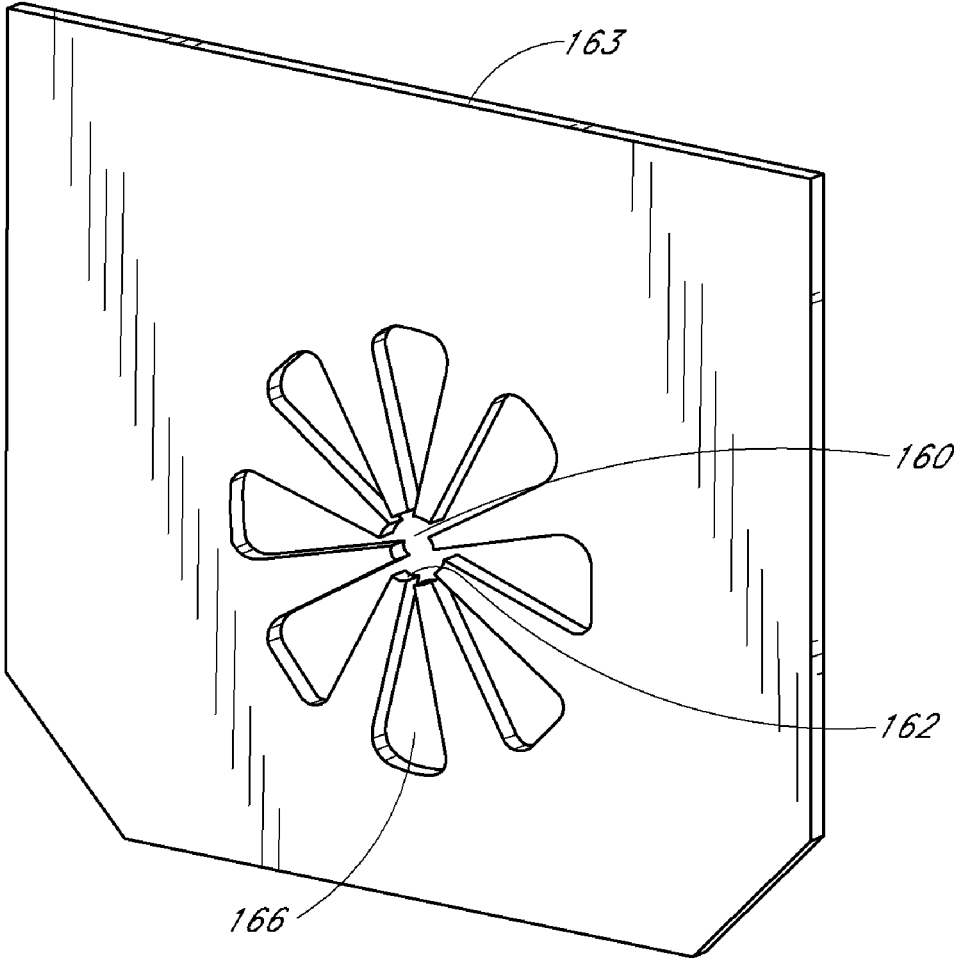

FIG. 12C

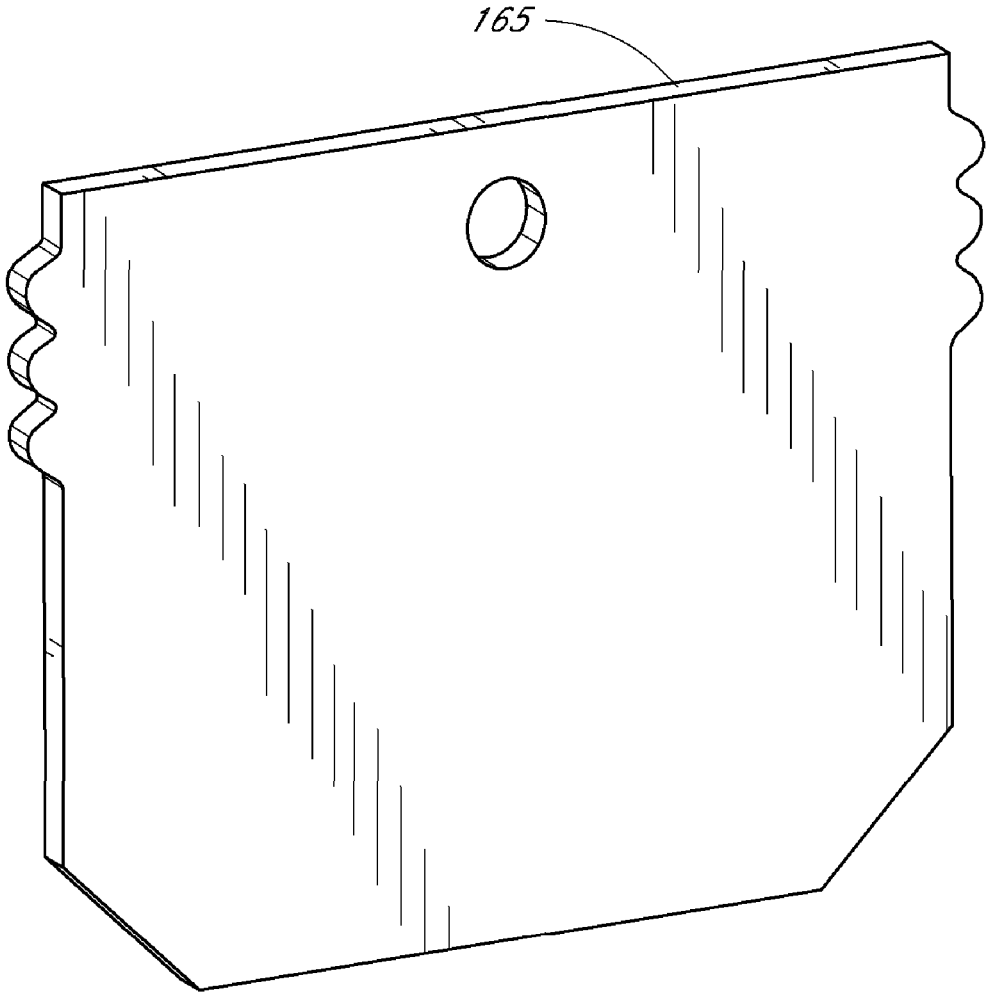

FIG. 13A

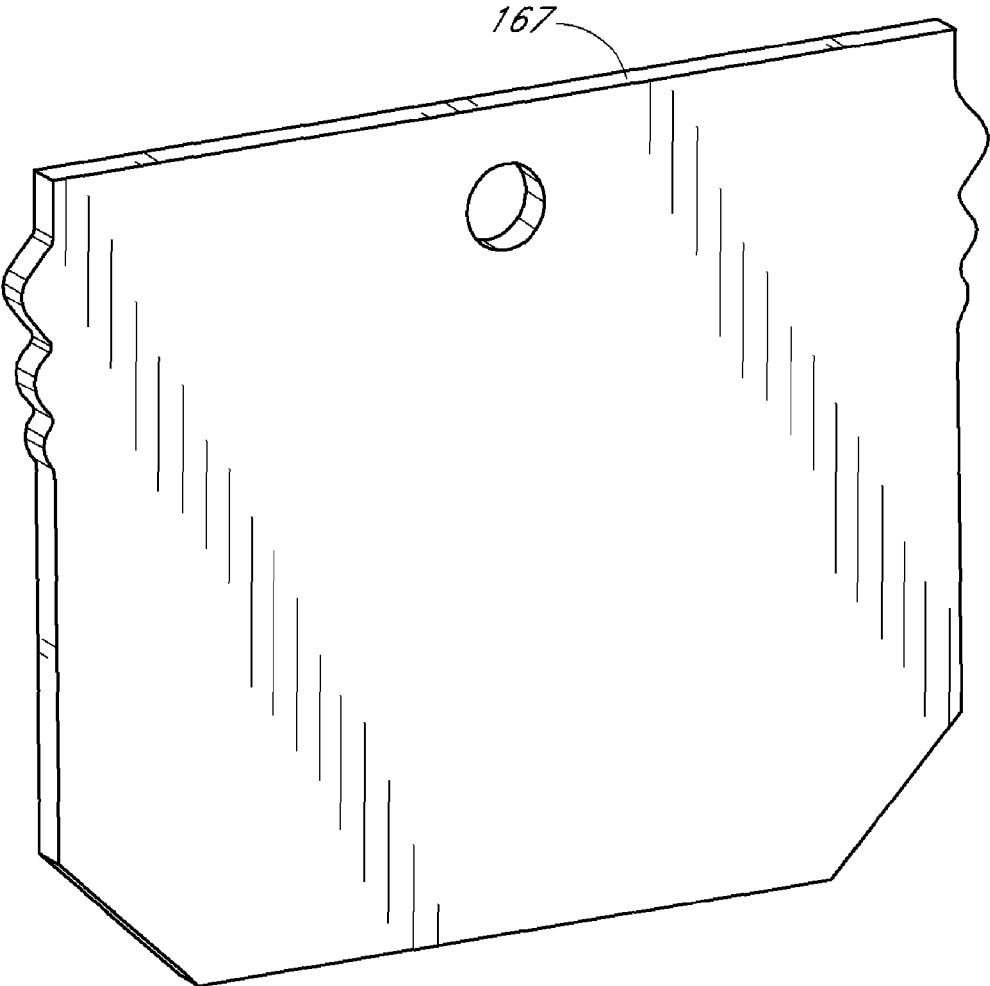

FIG. 13B

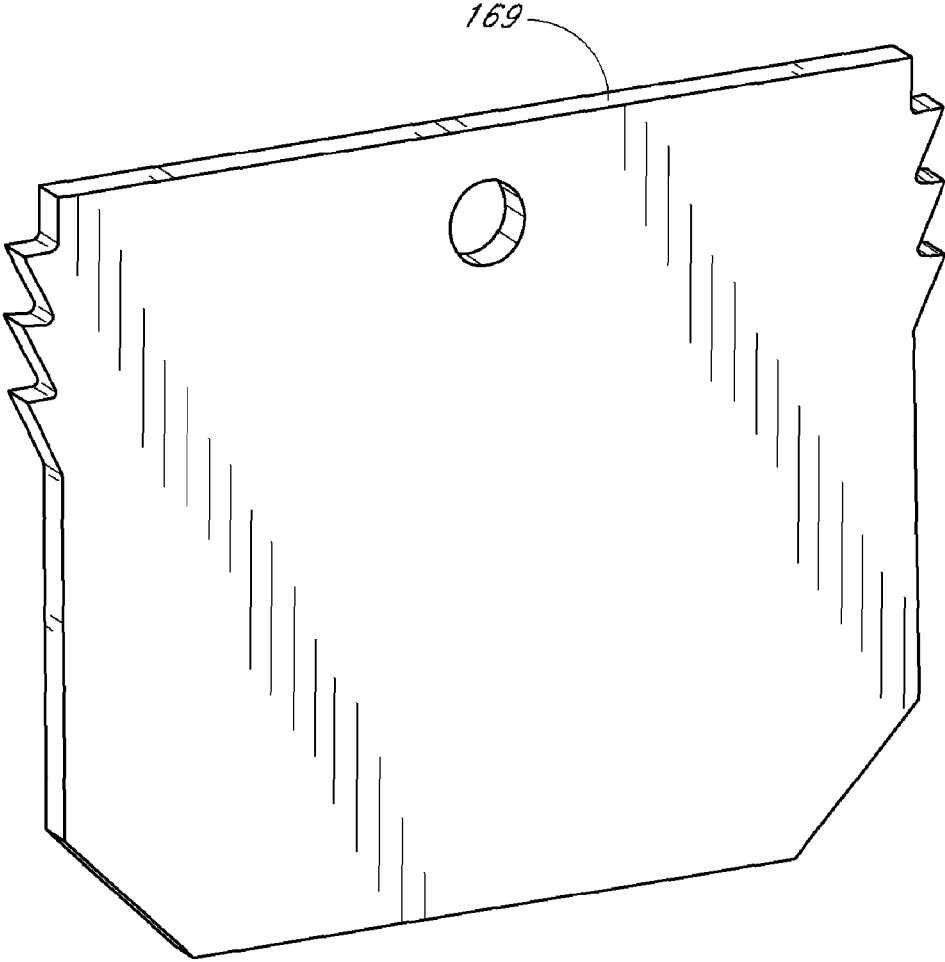

FIG. 13C

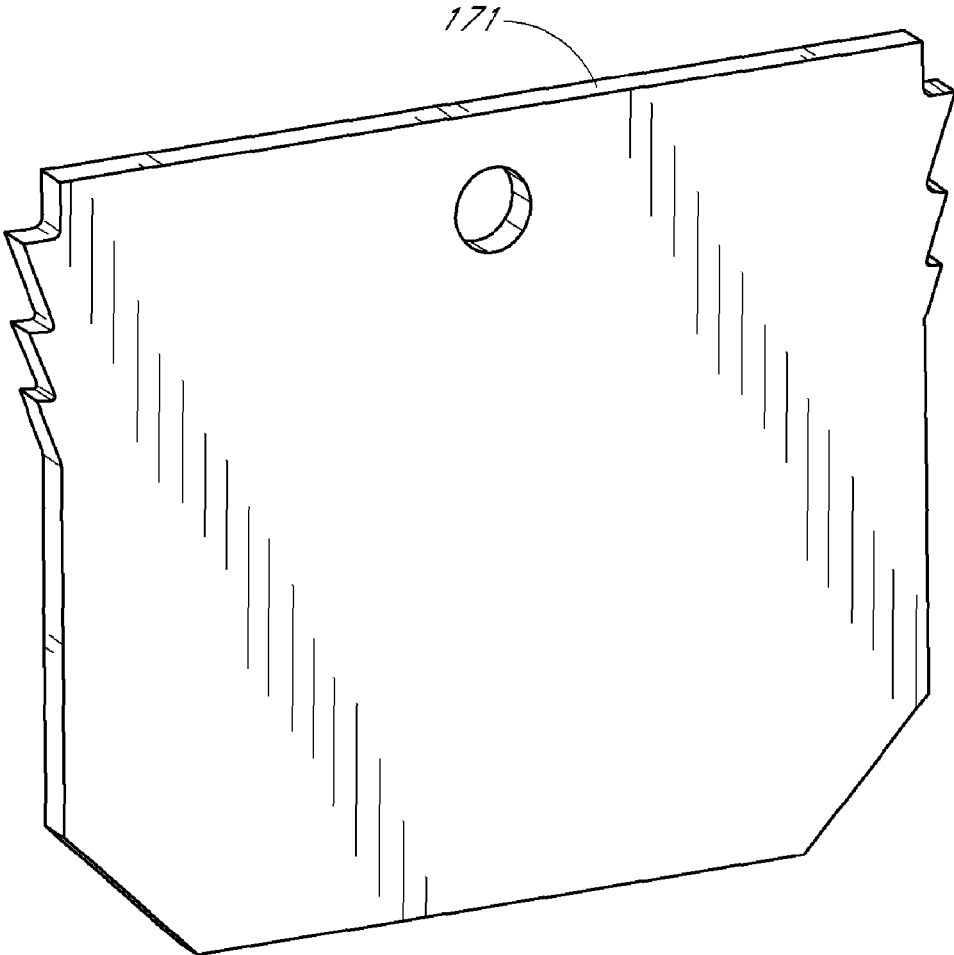

FIG. 13D

ACCESS DEVICE

Matter enclosed in heavy brackets [] appears in the original patent but forms no part of this reissue specification; matter printed in italics indicates the additions made by reissue; a claim printed with strikethrough indicates that the claim was canceled, disclaimed, or held invalid by a prior post-patent action or proceeding.

RELATED APPLICATIONS

This application is a continuation of U.S. patent application Ser. No. 12/019,598, filed on Jan. 24, 2008 and entitled "ACCESS DEVICE," issued as U.S. Pat. No. 7,922,696 on Apr. 12, 2011, which claims the benefit under 35 U.S.C. §119(e) to U.S. Provisional Patent Application Ser. No. 60/886,443, filed Jan. 24, 2007, the entire contents of each hereby incorporated by reference.

BACKGROUND OF THE INVENTION

1. Field of the Invention

This invention is generally directed to access devices for introducing and delivering a catheter cannula or sheath into an artery, vein, vessel, body cavity, or drainage site.

2. Description of the Related Art

A preferred non-surgical method for inserting a catheter or vascular sheath into a blood vessel involves the use of the Seldinger technique, which includes an access needle that is inserted into a patient's blood vessel. A guidewire is inserted through the needle and into the vessel. The needle is removed, and a dilator and sheath combination are then inserted over the guidewire. The dilator and sheath combination is then inserted a short distance through the tissue into the vessel, after which the dilator and guidewire are removed and discarded. The catheter may then be inserted through the sheath into the vessel to a desired location.

A number of vascular access devices are known. U.S. Pat. Nos. 4,241,019, 4,289,450, 4,756,230, 4,978,334, 5,124,544, 5,424,410, 5,312,355, 5,212,052, 5,558,132, 5,885,217, 6,120,460, 6,179,823, and 6,210,332 disclose examples of such devices. None of these devices, however, has the ease and safety of use that physicians and other healthcare providers would prefer and, thus, there is a need for an easier-to-use and safer vascular access device, especially one that would clearly indicate when a blood vessel has been punctured.

SUMMARY OF THE INVENTION

The present invention involves several features for an access device useful for the delivery of a catheter or sheath into a space within a patient's body, such as, for example, a blood vessel or drainage site. Without limiting the scope of this invention, its more prominent features will be discussed briefly. After considering this discussion, and particularly after reading the Detailed Description of the Preferred Embodiments section below in combination with this section, one will understand how the features and aspects of this invention provide several advantages over prior access devices.

One aspect of the present invention is an access device for placing a medical article within a body space. The device has a needle section that includes an elongated body and a needle hub. The elongated body has distal and proximal ends. The distal end is configured for insertion into a

patient's body. The proximal end is coupled with the needle hub. The device further includes a dilator portion including a dilator and a dilator hub. The dilator is coaxially disposed and slideable over the elongated body of the needle section with the dilator hub being disposed distal of the needle hub. The device further includes a sheath section that has a sheath and a sheath hub. The sheath is coaxially disposed and slideable over the dilator with the sheath hub being disposed distal of the dilator hub. The device further includes a first locking mechanism operably disposed between the needle hub and the dilator hub to inhibit at least unintentional axial movement between the needle section and the dilator portion when the first locking mechanism is engaged and a second locking mechanism operably disposed between the dilator hub and the sheath hub to inhibit at least unintentional axial movement between the dilator portion and the sheath section when the second locking mechanism is engaged. Each of said first and second locking mechanisms is configured to be engaged by moving the respective hubs in a non-axial manner relative to each other. The first locking mechanism is configured to move in a manner different from the manner in which the second locking mechanism is engaged.

Another aspect of the invention is an access device for placing a medical article within a body space. The device includes a needle section including an elongated needle body with a sharp distal tip and a needle hub from which the needle body extends. The device further includes a dilator portion that includes a dilator and a dilator hub. The dilator is coaxially disposed and slideable over the needle body with the dilator hub being disposed distal of the needle hub. The device further includes a sheath section that includes a sheath and a sheath hub. The sheath is coaxially disposed and slideable over the dilator with the sheath hub being disposed distal of the dilator hub. The device further includes a locking mechanism disposed within the dilator and selectively operating between the needle body and the dilator. The locking mechanism is configured to arrest axial movement of the needle body at least in the distal direction once the distal tip of the needle body is drawn into the dilator portion to sheath the distal tip.

Yet another aspect of the invention is an access device for placing a medical article within a body space. The device includes a dilator hub that has a passageway configured to receive an elongated needle. The needle has at least one side receptacle. The device further includes one or more fingers or tangs disposed in the dilator hub and configured to engage with the at least one side receptacle at least when the needle is retracted through the passageway.

Additionally, a releasable interlock can be provided in some embodiments to inhibit relative rotational movement between the needle section and the dilator section, at least when the needle is inserted into a patient. By inhibiting such relative rotational movement, communicating side openings in the needle and the dilator can be held in alignment to provide a simplified passageway through which the blood or fluid may flow. Thus, when the needle enters a blood vessel or drainage site in the patient, blood or other body fluid quickly flows into the passageway. The resulting blood or fluid flash is visible through the sheath section (or catheter) to indicate that the needle tip has entered the vessel or drainage site.

For example, but without limitation, the dilator portion or section can comprise, in some embodiments, a dilator hub and dilator having one or more side openings. The dilator hub may have a luer connection and a releasable locking mechanism. The releasable locking mechanism can be configured to releasably engage and secure the dilator section to

another part, such as the needle hub. When the needle hub and the dilator hub are releasably locked to prevent rotation therebetween, one or more of the side openings in the dilator are aligned with one or more side openings in the needle. The locking mechanism can also be configured to inhibit unintentional relative axial movement between the needle and the dilator.

The sheath section preferably, but not necessarily, includes a sheath and sheath hub. The sheath may be made partially or completely from a clear, translucent, semi-opaque, or transparent material. Such transparent, translucent, semi-opaque and clear materials allow a clinician the ability to see when blood or other body fluids flows into the needle, through the needle side opening(s), through the side dilator opening(s), and into the viewing space between the dilator and sheath.

These and other aspects of the present invention will become readily apparent to those skilled in the art from the following detailed description of the preferred embodiments, which refers to the attached figures. The invention is not limited, however, to the particular embodiments that are disclosed.

BRIEF DESCRIPTION OF THE DRAWINGS

These and other features, aspects, and advantages of the invention disclosed herein are described below with reference to the drawings of preferred embodiments, which are intended to illustrate and not to limit the invention.

FIG. 1A is a perspective view of a preferred embodiment of an access device configured in accordance with the present invention.

FIG. 1B is an enlarged plan view of a needle hub, a dilator hub, and a sheath hub of the access device illustrated in FIG. 1A, shown in an assembled state.

FIG. 1C is a perspective view of the assembly of the needle hub, dilator hub and sheath hub illustrated in FIG. 1B.

FIG. 2A is side view of a needle section of the embodiment depicted in FIG. 1A.

FIG. 2B is a cross-sectional view of the needle section of the embodiment depicted in FIG. 2A taken along line A-A.

FIG. 2C is an enlarged plan view of the needle hub of the needle section of FIG. 2B.

FIG. 3A is a side view of the dilator portion of the embodiment depicted in FIG. 1A.

FIG. 3B is a proximal end view of the dilator portion of FIG. 3A.

FIG. 3C is a cross-sectional view of the dilator portion of the embodiment depicted in FIG. 3A, taken along line B-B.

FIG. 3D is an enlarged perspective view of the dilator hub of the dilator portion of FIG. 3A.

FIG. 4A is a side view of a sheath section of the embodiment from FIG. 1A.

FIG. 4B is a proximal end view of the sheath section of FIG. 4A.

FIG. 4C is an enlarged perspective view of the sheath hub of the sheath section of FIG. 4A.

FIG. 5 is a side view of the access device of FIG. 1A.

FIG. 6 is an enlarged cross-sectional view of a portion of the embodiment illustrated in FIG. 5 which is circled by line C-C.

FIG. 7A is a schematic, enlarged cross-sectional view of a portion of the needle within the dilator and illustrates an embodiment of a locking mechanism configured in accordance with one aspect of the present invention.

FIGS. 7B-7D illustrate the operational steps of the locking mechanism of FIG. 7A when arresting relative axial movement between the needle and the dilator.

FIG. 8A is a similar cross-sectional view of a portion of a locking mechanism which is configured in accordance with another preferred embodiment of present invention. FIG. 8A illustrates the locking mechanism in an unlocked state.

FIG. 8B illustrates the locking mechanism of FIG. 8A in a locked state.

FIG. 9A is a schematic, enlarged cross-sectional view of a locking mechanism configured in accordance with an additional embodiment of the present invention. FIG. 9A illustrates the locking mechanism in an unlocked state.

FIG. 9B illustrates the locking mechanism of FIG. 9A in a locked state.

FIG. 10A is a schematic, enlarged cross-sectional view of a locking mechanism configured in accordance with a further embodiment of the present invention. FIG. 10A illustrates the locking mechanism in an unlocked state.

FIG. 10B is a cross-sectional view of the locking mechanism of FIG. 10A taken along lines 10B-10B.

FIG. 11 is an enlarged exploded view of a dilator hub and locking plate assembly configured in accordance with an additional preferred embodiment of the present invention.

FIG. 12A is an enlarged view of an embodiment of the locking plate that can be used with the dilator hub shown in FIG. 11.

FIG. 12B is an enlarged view of another embodiment of the locking plate that can be used with the dilator hub shown in FIG. 11.

FIG. 12C is an enlarged view of an additional embodiment of the locking plate that can be used with the dilator hub shown in FIG. 11.

FIGS. 13A-13D are enlarged views of perimeter shapes that the locking plate can have in accordance with additional embodiments of the present invention.

DETAILED DESCRIPTION OF THE PREFERRED EMBODIMENTS

The present disclosure provides an access device for the delivery of a catheter or sheath to a blood vessel or drainage site. FIG. 1 illustrates an access device **102** that is configured to be inserted into a blood vessel in accordance with a preferred embodiment of the present invention. While the access device is described below in this context (i.e., for vascular access), the access device also can be used to access and place a catheter or sheath into other locations within a patient's body (e.g., for draining an abscess) and for other purposes.

FIG. 1A is a perspective view of a preferred embodiment of an access device **102**. The access device **102** comprises a needle section **20**, a dilator portion **28**, a sheath section (e.g., catheter or cannula) **58**, and a guidewire **120**. In preferred embodiments, the dilator portion **28** is coaxially mounted on the needle section **20**, and the sheath section **58** is coaxially mounted on the dilator portion **28**. The needle section **20** comprises a needle **22** and a needle hub **21**. The needle hub **21** is disposed on a proximal end of the needle **22**. The dilator portion **28** comprises a dilator **30** and a dilator hub **32**. The dilator hub **32** is disposed on the proximal end of the dilator **30**. The sheath section **58** comprises a sheath **54** and a sheath hub **53**. The sheath hub **53** is disposed on the proximal end of the sheath **54**.

FIG. 1B is an enlarged plan view of the needle hub **21**, the dilator hub **32**, and the sheath hub **53** of the access device

illustrated in FIG. 1A, shown in an assembled state. The needle hub 21, the dilator hub 32, and the sheath hub 53 include structures that releasably interlock the hubs so as to provide a structural and fluid connection between the needle section 20, the dilator portion 28, and the sheath section 58.

FIG. 1C is a perspective view of the assembly of the needle hub 21, dilator hub 32 and sheath hub 53 illustrated in FIG. 1B. With reference to FIGS. 1A and 1B, the needle section 20, dilator portion 28, and sheath section 58 are interlocked at the proximal end 110 of the access device 102. In some embodiments, the releasable interlock between the needle section 20, dilator portion 28, and sheath section 58 is a tandem interlock where the dilator portion 28 is locked to the needle section 20 at interface 101 and the sheath section 58 is locked to the dilator portion 28 at interface 103. In addition to a structural connection, the interlocks provide a fluidic connection through the access device 102.

Preferably, the needle section 20 locks to the dilator portion 28 via a lock mechanism 26. The lock mechanism 26 may comprise an engaging mechanism such as hinged clips 27 with actuator sides 29. The hinged clips 27 may releasably engage and secure to corresponding catches 25 on the dilator portion 28. In some embodiments, the clip sides 29 engage and secure the dilator portion 28 by clipping to the outer lip of a luer connection 33 on the dilator portion 28. Although hinged clips 27 are shown, the lock member 26 may comprise any suitable engaging mechanism known in the art. In the illustrated embodiment, as best seen in FIG. 3B, the portions of the outer lip onto which the hinge clips 27 engage are flats to inhibit rotation of the needle hub 21 relative to the dilator hub 32 after a certain degree of relative rotation (e.g., 180 degrees) between the needle hub 21 and the dilator hub 32.

Similarly, the sheath section 58 is secured to the dilator portion 28 through a lock member 59. The sheath section 58 may, preferably, comprise a twist lock member 59 so that the user may releasably engage and secure the dilator portion 28 to the sheath section 58. In some preferred embodiments, the dilator portion 28 comprises teeth or prongs that are configured to mate or attach to corresponding areas on the sheath section 58. Preferably, the needle 20, dilator 28 and sheath 58 are releasably locked so that a physician or user may remove sections or portions of the access device as needed for treatment.

FIG. 2A is side view of the needle section 20 of the embodiment depicted in FIG. 1A. FIG. 2B is a cross-sectional view of the needle section 20 depicted in FIG. 2A taken along line A-A. As shown in both FIGS. 2A and 2B, the needle section 20 has a needle 22, distal portion 106, and proximal portion 24. Preferably, the proximal portion 24 has the needle hub 21 and the lock member 26. In addition, the needle 22 may have a bevel tip 108 disposed on the distal portion 106. The needle 22 may further comprise one or more side openings 34.

FIG. 2C is an enlarged plan view of the needle hub 21 of the needle section 20 of FIG. 2B. As most clearly shown in FIG. 2C, the needle hub 21 may also have a luer connection 35 at the proximal portion 24 of the needle 20. This allows the physician or healthcare provider, for example, to introduce a guidewire 120 through the hollow portion of the luer connection 35, through the needle 22, and into a punctured vessel. Additionally, a physician or healthcare provider may also attach a syringe to the luer connection 35 to perform other procedures as desired.

As discussed above, in preferred embodiments, the needle hub 21 comprises the lock member 26. The lock member 26 may be configured to lock or secure another part such as, for

example, the dilator portion 28 or the sheath section 58, to the needle section 20. As shown most clearly in FIG. 2C, the lock member 26 can comprise an engaging mechanism such as a pair of hinged clips 27, although other types of locking mechanisms comprising tabs and/or slots can also be used. Preferably, the clip sides 29 of the hinged clips 27 can engage a lipped surface such as the outer lip of a luer connection 33, shown in FIG. 1A. Once engaged, the clip sides 29 prevent the locked part from undesired slipping or releasing. In certain embodiments, the clips 27 are hinged to provide a bias towards the center of the needle hub 21. Preferably, the bias prevents the secured part from slipping or disengaging from the hinged clips 27. More preferably, the bias of the hinged clips 27 can be overcome by simultaneously applying pressure on the sides 29 of the clips 27 to release, for example, the luer connection 33 from the needle hub 21. To apply the appropriate releasing pressure, a physician or healthcare provider may, for example, place an index finger and thumb on the sides 29 of the hinged clips 27 and apply squeezing pressure to overcome the hinge bias. The hinged clips 27 will, preferably, release only when sufficient releasing pressure is applied to both clip sides 29.

As shown most clearly in FIG. 2A, the needle proximal portion 24 may have color coding, words, or other indicia, such as a pivot or notch, to indicate to the operator the position of the bevel tip 108 relative to the dilator 28 or the sheath section 58. For example, the arrow embedded into the needle hub 21 indicates the bevel up position of the needle 22 and may further indicate to the healthcare provider the proper way to use the device. Also, there may be a mechanical fit between the dilator 28 and the needle 22 so that the physician or healthcare provider would sense by feel or sound (e.g., by a click) when the needle 22 has been rotated to change the position of the bevel tip 108.

FIG. 3A is a side view of the dilator portion 28 of the embodiment depicted in FIG. 1A. FIG. 3B is a proximal end view of the dilator portion 28 of FIG. 3A. FIG. 3C is a cross-sectional view of the dilator portion 28 of the embodiment depicted in FIG. 3A, taken along line B-B. As shown, the dilator portion 28 may comprise the dilator 30 and the dilator hub 32. The dilator 30 may further comprise one or more side openings 111. The dilator hub 32 preferably comprises a luer connection 33 with an outer lip 37. In some embodiments, the outer lip 37 can be configured to engage to the lock member 26 on the needle section 20 illustrated in FIG. 2C.

Additionally, the dilator 30 may be coaxially mounted to the needle 22 by slipping a hollow section 113 of the dilator 30 over the needle 22 and releasably securing the dilator hub 32 to the needle hub 21. Preferably, the proximal end 45 of the dilator hub 32 is configured to mechanically fit and interlock with the needle lock member 26 to inhibit at least some rotational and axial motion. More preferably, the dilator 30 is releasably mounted to the needle 22 so that the dilator 30 can be mounted and released, or vice versa, from a coaxial position relative to the needle 22.

FIG. 3D is an enlarged perspective view of the dilator hub 32 of the dilator portion 28 of FIG. 3A. As is most clearly illustrated in FIG. 3D, the dilator hub 32 may further comprise a locking mechanism 39. The locking mechanism 39 comprises one or more posts, teeth, or prongs projecting from the dilator hub 32. The locking mechanism 39, which may be in the form of teeth, can be configured to mate or attach to corresponding receiving areas disposed on another part such as the sheath section 58 or the needle hub 21. This locking mechanism 39 will be explained in greater detail in the following section.

FIG. 4A is a side view of the sheath section 58 of the embodiment from FIG. 1A. FIG. 4B is a proximal end view of the sheath section 58 of FIG. 4A. In preferred embodiments, the sheath section 58 comprises a sheath 54 and a sheath hub 53. The sheath 54 may also be made partially or completely from clear, translucent, transparent, or semi-opaque material. The sheath hub 53 may further comprise winged ends 55 and a lock member 59.

FIG. 4C is an enlarged perspective view of the sheath hub 53 of the sheath section 58 of FIG. 4A. Preferably, the locking member 59 may comprise a locking or attaching structure that mates or engages with a corresponding structure. As most clearly shown in FIGS. 4B and 4C, the locking member 59 may comprise indentations, bumps, or grooves designed to engage and secure the locking mechanism or teeth 39 on the dilator hub 32 described above with reference to FIG. 3D.

The sheath hub 53, as best seen in FIGS. 4B and 4C, preferably is designed so that the locking mechanism or teeth 39 of the dilator hub 32 can enter the sheath hub 53 substantially unobstructed. However, in use, once the sheath hub 53 is placed at a desired location over the dilator 30, the physician or healthcare provider can twist the sheath hub 53 and disengage or engage the locking member 59. The locking member 59 can be, for example, a protruding bump, dent, etc., that creates a mechanical fit so that the dilator hub 32 and the sheath hub 53 are releasably interlocked. In the illustrated embodiment, the locking member 59 of the sheath hub 53 comprises a pair of axial arranged grooves which extend from a distal side of the sheath hub 53 and terminate at a protruding bump, dent, etc. Preferably, the locked position can be disengaged by twisting the dilator hub 32 relative to the sheath hub 53. Additionally, the sheath hub may comprise wings 55 or handle structures to allow for easy release and removal of the sheath 54 from other parts of the access device 102.

In some applications, the wings 55 are sized to provide the healthcare provider with leverage for breaking apart the sheath hub 53. For example, the sheath hub 53 may comprise a thin membrane 61 connecting the halves of the sheath hub 53. The membrane 61 is sized to keep the halves of the sheath hub 53 together until the healthcare provider decides to remove the sheath hub 53 from the access device. The healthcare provider manipulates the wings 55 to break the membrane 61 and separate the sheath hub 53 into removable halves.

FIG. 5 is a side view of the access device of FIG. 1A in which the needle section 20, dilator portion 28, and sheath section 58 are interlocked together. In the assembly, as noted above the needle section 20, dilator portion 28 and sheath section 58 are coaxially disposed about a common longitudinal axis and form a central fluid connection.

FIG. 6 is an enlarged cross-sectional view of a portion of the embodiment illustrated in FIG. 5 which is circled by line C-C. As noted above, the needle 22, preferably, comprises one or more side openings 34 in its side wall. Additionally, the dilator may comprise one or more side openings 111. FIG. 6, however, illustrates the alignment between only one set of corresponding side openings. Other sets of side openings can also be aligned or be misaligned depending upon the relative orientations of the needle and the dilator.

Preferably the dilator 30 may be coaxially positioned to minimize the annular space 36 between the needle 22 and the dilator 30. The inner surface 38 of the dilator 30 need not, though it can, lie directly against the outer-surface 40 of the needle 22. Preferably, the annular interface 36 between the outer-surface 40 of the needle 22 and the inner surface

38 of the dilator 30 is minimized to inhibit the flow of blood or its constituents (or other bodily fluids) into the annular interface 36 between the dilator 30 and needle 22. Advantageously, this feature minimizes the blood's exposure to multiple external surfaces and reduces the risk of contamination, infection, and clotting.

The sheath 54 is made partially or completely from clear, semi-opaque, translucent, or transparent material so that when blood flows into the needle 22, (1) through the needle side opening 34, (2) through the dilator side opening 111, and (3) into an annular space 60 between the dilator 30 and the sheath 54, the physician or healthcare provider can see the blood. This will indicate to the physician or healthcare provider that the bevel tip 108 of the needle 22 has punctured a blood vessel.

More preferably, the dilator 30 can be coaxially mounted to the needle 22 such that at least one side opening 34 disposed on the needle 22 is rotationally aligned with at least one side opening 111 on the dilator 30. In some embodiments, the needle 22 and dilator 30 may (both) have multiple side openings 34, 111 where some or all of these side openings 34, 111 can be rotationally aligned. Preferably, the needle 22 and dilator 30 maintain rotational alignment so that blood flows substantially unobstructed through the needle side opening 34 and dilator side opening 111.

While the side openings 34, 111 in the needle 22 and the dilator 30 are aligned in the embodiment illustrated in FIG. 6, the side openings alternatively can overlap with each other or can be connected via a conduit. The conduit can be formed between the side openings 111, 34 in the dilator and the needle.

In accordance with another aspect of the present invention, there is provided an interlock or interconnection between the needle 22 and at least one of the dilator 30 or dilator hub 32. The interlock or interconnection inhibits the bevel tip 108 disposed on the distal portion 106 of the needle 22 from being advanced beyond the distal end of the dilator 30 once the dilator 30 has been advanced over the needle 22 during use. The dilator 30 thus sheaths the sharp bevel tip 108 of the needle 22 to inhibit accidental needle sticks from occurring.

FIG. 7A is a schematic, enlarged cross-sectional view of a portion of the needle 22 within the dilator 30 and illustrates an embodiment of a locking mechanism 115 configured in accordance with one aspect of the present invention. When engaged, the locking mechanism 115 inhibits movement of the needle 22 with respect to the dilator 30 in at least one direction. For example, the locking mechanism 115 can inhibit movement of the needle 22 at least in the distal direction once the distal tip of the needle body is drawn into the dilator portion to sheath the distal tip. The embodiment of the locking mechanism 115 illustrated in FIG. 7A comprises one or more arms or tangs 117, 119, one or more bases 121, 123, and one or more pivot couplings or hinges 127, 129.

The arm 117 may be axially aligned with the arm 119. Alternatively, the arms 117, 119 may be offset from each other in a radial direction. The arms 117, 119 may be slightly rotated relative to each other or disposed at different radial locations on the inside surface of the dilator 30. The tang or arm 117, 119 may move in a direction generally transverse to a longitudinal axis of the needle body when engaging the receptacle or hole 131.

The locking mechanism 115 is illustrated on the dilator 30. However, the needle 22 may instead comprise the locking mechanism 115. In the illustrated embodiment, the needle 22 comprises a receptacle, recess, opening, or hole

131 which interacts with the locking mechanism 115 of the dilator 30 when the needle 22 is sufficiently retracted into the dilator 30. The receptacle, recess, opening, or hole 131 may extend entirely around the needle 22 forming an annular groove or around only a portion of the needle 22.

For embodiments that have arms 117, 119 disposed at different radial locations on the inside surface of the dilator 30, the needle 22 may comprise more than one recess, opening, or hole 131. The multiple recesses, openings, or holes 131 are disposed at radial locations around the outer surface of the needle 22 that correspond to the radial spacing of the arms 117, 119 around the inside surface of the dilator 30.

The arm 117 is coupled to the base 121 via hinge 127 and rotates from an unlocked position to a locked position in a counter-clockwise direction. The arm 119 is coupled to the base 123 via hinge 129 and rotates from an unlocked position to a locked position in a clockwise direction. In the illustrated embodiment, each arm 117, 119 rotates approximately 90 degrees between the unlocked position and the locked position. However, the locked position may be more or less than 90 degrees from the unlocked position. The arms 117, 119 need only rotate a sufficient amount to allow their distal ends to abut against a portion of the perimeter of the recess, opening, or hole 131.

The recess, opening, or hole 131 in the needle 22 locally increases a gap located between an outside surface of the needle 22 and an inside surface of the dilator 30 a sufficient amount to allow the arms 117, 119 to rotate about their respective hinges 121, 123 and towards the locked position. When the arm 117 is in the locked position, the needle 22 is inhibited from relative axial movement with respect to the dilator 30 in a proximal direction. When the arm 119 is in the locked position, the needle 22 is inhibited from relative axial movement with respect to the dilator 30 in a distal direction.

The one or more bases 121, 123 are attached to or integral with the dilator 30 and extend generally towards the coaxially aligned needle 22. The bases 121, 123 are sized so as to not interfere with movement of the needle 22 through the dilator 30 while providing hinge points for attachment of the arms 117, 119. The arms 117, 119 are sized to allow movement of the needle 22 through the dilator 30 when the arms 117, 119 are in the unlocked position. The hinges 127, 129 permit the arms 117, 119 to move from the unlocked position illustrated in FIG. 7A to a locked position illustrated in FIG. 7D.

Each arm 117, 119 can separately move to the locked position when the arm 117, 119 is axially aligned with the recess, opening, or hole 131 in the needle 22. Once in the locked position, the hinge 127, 129 does not permit the arm 117, 119 to move back to the unlocked position. In some embodiments, the hinges 127, 129 slightly bias the arms 117, 119 to move towards the locked position. For example, the tang or arm 117, 119 can be biased toward the receptacle, recess, opening, or hole 131.

FIGS. 7B-7D illustrate the operational steps of the locking mechanism 115 of FIG. 7A when arresting relative axial movement between the needle 22 and the dilator 30. FIG. 7B illustrates the arms 117, 119 in the unlocked position. In the unlocked position, the recess, opening, or hole 131 in the needle 22 is not axial aligned with the arms 117, 119 of the locking mechanism 115. A healthcare provider can move the needle 22 with respect to the dilator 30 in both proximal and distal directions as long as the recess, opening, or hole 131 in the needle 22 stays on the proximal side of the locking mechanism 115 as is illustrated in FIG. 7B.

FIG. 7C illustrates the arm 117 in the locked position. In the locked position, the distal end of the arm 117 is disposed within the recess, opening, or hole 131 in the needle 22. Once in the locked position, the hinge 127 does not permit the arm 117 to rotate back to the unlocked position. When the arm 117 is in the locked position, the needle 22 may still move in a distal direction with respect to the dilator 32 until the recess, opening, or hole 131 is aligned with the arm 119.

FIG. 7D illustrates both arms 117, 119 in the locked position. In the dual locked position, the distal ends of the arms 117, 119 are disposed within the recess, opening, or hole 131 in the needle 22. Once in the dual locked position, the hinges 127, 129 do not permit the arms 117, 119 to rotate back to the unlocked position. When the arm 119 is in the locked position, the needle 22 is inhibited from moving in the distal direction with respect to the dilator 32.

FIG. 8A is a similar cross-sectional view of a portion of a locking mechanism 137 which is configured in accordance with another preferred embodiment of present invention. When engaged, the locking mechanism 137 inhibits movement of the needle 22 with respect to the dilator 30 in both directions. The embodiment of the locking mechanism 137 illustrated in FIG. 8A comprises one or more pairs of v-shaped arms 135, 137. The pairs of arms 135, 137 are disposed on diametrically opposite sides of the needle 22. Alternatively, the arms 135, 137 may be offset from each other in a radial direction more or less than 180 degrees apart.

The locking mechanism 133 is illustrated on the dilator 30. However, the needle 22 may instead comprise the locking mechanism 133. In the illustrated embodiment, the needle 22 comprises a recess, opening, or hole 139 which interacts with the locking mechanism 133 of the dilator 30 when the needle 22 is sufficiently retracted into the dilator 30. The receptacle, recess, opening, or hole 139 may extend entirely around the needle 22 forming an annular groove or around only a portion of the needle 22. The needle 22 may comprise more than one recess, opening, or hole 139. The multiple recesses, openings, or holes 139 are disposed at radial locations around the outer surface of the needle 22 that correspond to the radial spacing of the arms 135, 137 around the inner surface of the dilator 30.

The pairs of arms 135, 137 extend from the dilator 30 towards the needle 22. Each pair of arms 135, 137 is biased towards the needle 22 and is illustrated in a compressed or unlocked state in FIG. 8A. In the unlocked state or position, the recess, opening, or hole 139 in the needle 22 is not axial aligned with the arms 135, 137 of the locking mechanism 133. A healthcare provider can move the needle 22 with respect to the dilator 30 in both proximal and distal directions as long as the recess, opening, or hole 139 in the needle 22 stays on the proximal side of the locking mechanism 133 as is illustrated in FIG. 8B. Each pair of arms 135, 137 gently presses against the outer surface of the needle 22 as the needle 22 slides within the dilator 30 when the arms are in the unlocked state. Each pair of arms 135, 137 can rotate or bend to reach a locked state when the arms 135, 137 are axially aligned with the recess, opening, or hole 139.

In the illustrated embodiment, each arm of each pair of arms 135, 137 rotates towards the other arm between the unlocked position and the locked position. The arms 135, 137 need only be sufficiently biased so that when the arms 135, 137 align with the hole 139 their distal ends abut against a portion of the perimeter of the recess, opening, or hole 139. In the locked position, the distal ends of the arms 135, 137 are disposed within the recess, opening, or hole 139 in the needle 22.

11

The recess, opening, or hole 139 in the needle 22 locally increases a gap located between an outside surface of the needle 22 and an inside surface of the dilator 30 a sufficient amount to allow the arms 135, 137 to flex from their biased or unlocked state towards the locked position. FIG. 8B illustrates the pair of arms 135 of the locking mechanism 133 of FIG. 8A in a locked state. When one or both of the pair of arms 135, 137 is in the locked position the needle 22 is inhibited from relative axial movement with respect to the dilator 30 in both proximal and distal directions.

In the unlocked state illustrated in FIG. 8A, the arms 135, 137 are biased to contact the needle 22 but not substantially interfere with movement of the needle 22 through the dilator 30. The arms 135, 137 are sized in their unbiased or locked state to inhibit movement of the needle 22 through the dilator 30. The biasing of the arms 135, 137 moves the arms 135, 137 from the unlocked position illustrated in FIG. 8A to the locked position illustrated in FIG. 8B.

Each pair of arms 135, 137 can separately move to the locked position when the pair of arms 135, 137 is axially aligned with the recess, opening, or hole 139 in the needle 22. Once in the locked position, the size and shape of the pair of arms 135, 137 inhibit movement back to the unlocked position.

FIG. 9A is a schematic, enlarged cross-sectional view of a locking mechanism 141 configured in accordance with an additional embodiment of the present invention. When engaged, the locking mechanism 141 inhibits movement of the needle 22 with respect to the dilator 30 in both directions. The embodiment of the locking mechanism 141 illustrated in FIG. 9A comprises a protrusion 143.

The locking mechanism 141 is illustrated on the dilator 30. However, the needle 22 may instead comprise the locking mechanism 141. In the illustrated embodiment, the needle 22 comprises a recess, opening, or hole 145 which interacts with the locking mechanism 141 of the dilator 30 when the needle 22 is sufficiently retracted into the dilator 30. The receptacle, recess, opening, or hole 145 may extend entirely around the needle 22 forming an annular groove or around only a portion of the needle 22. The needle 22 may comprise more than one recess, opening, or hole 145.

The protrusion 143 extends from the dilator 30 towards the needle 22 and is biased towards the needle 22. FIG. 9A illustrates the protrusion 143 in a compressed or unlocked state. In the unlocked state or position, the recess, opening, or hole 145 in the needle 22 is not axial aligned with the protrusion 143 of the locking mechanism 141. A healthcare provider can move the needle 22 with respect to the dilator 30 in both proximal and distal directions as long as the recess, opening, or hole 145 in the needle 22 stays on the proximal side of the locking mechanism 141 as is illustrated in FIG. 9A. The protrusion 143 gently presses against the outer surface of the needle 22 as the needle 22 slides within the dilator 30 when the locking mechanism 141 is in the unlocked state. At least a portion of the protrusion 143 can extend to reach a locked state when the protrusion 143 is axially aligned with the recess, opening, or hole 145.

The protrusion 143 need only be sufficiently biased so that when the protrusion 143 aligns with the hole 145 its distal end abuts against a portion of the perimeter of the recess, opening, or hole 145. In the locked position, the distal end of the protrusion 143 is disposed within the recess, opening, or hole 145 in the needle 22.

The recess, opening, or hole 145 in the needle 22 locally increases a gap located between an outside surface of the needle 22 and an inside surface of the dilator 30 a sufficient amount to allow the protrusion 143 to flex or extend from its

12

biased or unlocked state towards the locked position. FIG. 9B illustrates the protrusion 143 of the locking mechanism 141 of FIG. 9A in a locked state. When the protrusion 143 is in the locked position the needle 22 is inhibited from relative axial movement with respect to the dilator 30 in both proximal and distal directions.

In the unlocked state illustrated in FIG. 9A, the protrusion 143 is biased to contact the needle 22 but not substantially interfere with movement of the needle 22 through the dilator 30. The protrusion 143 is sized in its unbiased or locked state to inhibit movement of the needle 22 through the dilator 30. The biasing of the protrusion 143 moves the distal end of the protrusion from the unlocked position illustrated in FIG. 9A to the locked position illustrated in FIG. 9B.

FIG. 10A is a schematic, enlarged cross-sectional view of a locking mechanism 147 configured in accordance with a further embodiment of the present invention. When engaged, the locking mechanism 141 inhibits movement of the needle 22 with respect to the dilator 30 in both directions. The embodiment of the locking mechanism 141 illustrated in FIG. 10A comprises a detent 149.

The locking mechanism 147 is illustrated on the dilator 30. However, the needle 22 may instead comprise the locking mechanism 147. In the illustrated embodiment, the needle 22 comprises a recess, opening, or hole 151 which interacts with the locking mechanism 149 of the dilator 30 when the needle 22 is sufficiently retracted into the dilator 30. The receptacle, recess, opening, or hole 151 may extend entirely around the needle 22 forming an annular groove or around only a portion of the needle 22. The needle 22 may comprise more than one recess, opening, or hole 151.

The detent 149 extends from the dilator 30 towards the needle 22 and rides in an axial groove in the needle 22. The proximal end of the groove connects with the hole 151. FIG. 10A illustrates the detent 149 in an unlocked state. In the unlocked state or position, the recess, opening, or hole 151 in the needle 22 is not axial aligned with the detent 149 of the locking mechanism 147. A healthcare provider can move the needle 22 with respect to the dilator 30 in both proximal and distal directions as long as the recess, opening, or hole 151 in the needle 22 stays on the proximal side of the locking mechanism 147 as is illustrated in FIG. 10A. The detent 149 rides in the groove in the outer surface of the needle 22 as the needle 22 slides within the dilator 30 when the locking mechanism 147 is in the unlocked state. The detent 149 and groove further inhibit relative rotation of the needle 22 with respect to the dilator 30. The detent 149 reaches a locked state when the detent 149 is axially aligned with the recess, opening, or hole 151.

The recess, opening, or hole 151 in the needle 22 locally increases a gap located between a bottom surface of the groove in the needle 22 and an inside surface of the dilator 30 a sufficient amount to allow the detent 149 to flex or extend from a biased or unlocked state towards the locked position. FIG. 10B illustrates the detent 149 of the locking mechanism 147 in the unlocked state. While not illustrated, when the detent 149 is in the locked position the needle 22 is inhibited from relative axial movement with respect to the dilator 30 in both proximal and distal directions.

In the unlocked state illustrated in FIGS. 10A and 10B, the detent 149 is slightly biased to contact the bottom of the groove in the needle 22 but not to substantially interfere with movement of the needle 22 through the dilator 30. The detent 149 is sized in its unbiased or locked state to inhibit movement of the needle 22 through the dilator 30.

FIG. 11 is an enlarged exploded view of a dilator hub and locking plate assembly 153 configured in accordance with

an additional preferred embodiment of the present invention. The assembly 153 includes a dilator hub 155 and one or more fingers or tangs 162. The one or more fingers or tangs 162 are spaced and sized such that they enter or snap into the side hole or holes in the needle 22 when the needle 22 is retracted. In some applications, a single finger or tang 162 is employed.

The one or more fingers or tangs 162 inhibit the bevel tip 108 disposed on the distal portion 106 of the needle 22 from being advanced beyond the distal end of the dilator 30 once the dilator 30 has been advanced over the needle 22 during use. The dilator 30 thus sheaths the sharp bevel tip 108 of the needle 22 to inhibit accidental needle sticks from occurring.

The one or more fingers or tangs 162 may be integrated into the dilator hub 155 or part of a separate structure that is combined with the dilator hub 155. In the embodiment illustrated in FIG. 11, the one or more fingers or tangs 162 are formed on a separate structure in the form of a locking plate 157(a)-(c). In this way, the locking plate 157(a)-(c) comprises the one or more fingers or tangs 162. Exemplary locking plates 157(a)-(c) are illustrated in FIGS. 12A-12C. Of course the structure of the locking plates 157(a)-(c) is not limited to the illustrated embodiments. For example, the locking plate 157 could be configured to include one or more of the locking mechanisms illustrated in FIGS. 7A, 8A, 9A, and 10A. For embodiments that have the one or more fingers or tangs 162 integrated into the dilator 155, the assembly 153 need not include a separate locking plate 157.

The dilator hub 155 and locking plate 157(a)-(c) may be separately manufactured and assembled as is illustrated in FIG. 11 or manufactured as a unitary assembly. The dilator hub 155 and locking plate 157(a)-(c) may be manufactured from the same or different materials, including, for example, plastics, metals, combinations thereof, and other materials. The locking plate 157 can be co-molded within the dilator hub 155 to form a unitary assembly. For example, a metal locking plate 157 can be molded into a plastic dilator hub 155. As explained above, a separate structure in the form of the locking plate 157 is for the In some applications, the locking plates 157(a)-(c) are movable with respect to the dilator hub 155 between unlocked and locked positions.

The dilator hub 155 is similar to the dilator hub 32 illustrated in FIG. 3A except that the dilator hub 155 is configured to slidably receive the one or more locking plates 157(a)-(c) through one or more slots 158(a)-(c). While multiple locking plates 157(a)-(c) and slots 158(a)-(c) are illustrated in FIG. 11, only a single locking plate 157(a)-(c) and slot 158(a)-(c) can inhibit movement of the needle 22. In some applications, multiple locking plates 157(a)-(c) are inserted from different sides of the dilator hub 155 so that the fingers or tangs 162 from the locking plates 157(a)-(c) combine to completely surround the needle 22 even though separately the tangs or fingers 162 of each locking plate 157 would not surround the needle 22. The slot 158(a)-(c) need not be arranged perpendicular to the axis of the needle 22 or located in a specific side or surface of the dilator hub 155 as is illustrated in FIG. 11. Multiple locking plates 157(a)-(c) may be inserted into a single slot 158.

A healthcare provider slides the locking plate 157(a)-(c) from an unlocked position to a locked position relative to the dilator hub 155. The locking plate 157(a)-(c) may be completely removed from the slot 158(a)-(c) or partially inserted into the slot 158(a)-(c) when in the unlocked position. When the locking plate 157(a)-(c) is in the locked position, the needle 22 is disposed in a hole or center region 160 of the

locking plate 157(a)-(c). The small size of the guide wire 120 inside the needle 22 does not affect the locking feature of the assembly.

FIG. 12A is an enlarged view of an embodiment of a locking plate 159 that can be used with the dilator hub 155 shown in FIG. 11. The locking plate 159 comprises a hole 160 surrounded by one or more fingers or tangs 162. An opening 164 extends from an outer perimeter of the locking plate 159 to the hole 160. The opening 164 permits the locking plate 159 to be inserted into the dilator hub 155 after the needle 22 is inserted through the dilator hub 155. The needle 22 passes through the opening 164 as the locking plate 159 is slid into the slot 158 and eventually enters the hole 160 when the locking plate 159 is in the locked position or state. Since the one or more fingers or tangs 162 do not extend entirely around the needle 22 when the needle 22 is inserted through the dilator hub 155, preferably the one or more side holes, receptacles, or annular groove in the needle 22 extend or are spaced radially about the needle 22 so that one of the fingers or tangs 162 will catch the one or more side holes, receptacles, or annular groove when the one or more side holes, receptacles, or annular groove passes through the locking plate 159.

When in the locked position, at least one of the distal ends of the fingers or tangs 162 extends a sufficient distance toward the needle 22 to enter a hole or slot in the needle 22 and inhibit further axial movement of the needle 22. In some applications, the hole or slot in the needle 22 falls onto the finger or tang 162. The hole may be the one or more side openings 34 in the side wall of the needle 22 or the receptacle, recess, opening, or hole 131, 139, 145, and 151 illustrated in, for example, FIGS. 7A, 8A, 9A, and 10A, respectively. In some applications, the receptacle, recess, opening, or hole 131, 139, 145, and 151 is the same structure as the one or more side openings 34.

FIG. 12B is an enlarged view of another embodiment of a locking plate 161 that can be used with the dilator hub 155 shown in FIG. 11. The locking plate 161 comprises a hole 160 surrounded by one or more fingers or tangs 162. An opening 164 extends from an outer perimeter of the locking plate 161 to the hole 160. The opening 164 permits the locking plate 161 to be inserted into the dilator hub 155 after the needle 22 is inserted through the dilator hub 155. The needle 22 passes through the opening 164 as the locking plate 161 is slid into the slot 158 and eventually enters the hole 160 when the locking plate 161 is in the locked position or state.

Since the one or more fingers or tangs 162 do not extend entirely around the needle 22 when the needle 22 is inserted through the dilator hub 155, preferably the one or more side holes, receptacles, or annular groove in the needle 22 extend or are spaced radially about the needle 22 so that one of the fingers or tangs 162 will catch the one or more side holes, receptacles, or annular groove when the one or more side holes, receptacles, or annular groove passes through the locking plate 161.

FIG. 12C is an enlarged view of an additional embodiment of a locking plate 163 that can be used with the dilator hub 155 shown in FIG. 11. The locking plate 163 comprises a hole 160 surrounded by one or more fingers or tangs 162. Unlike the embodiments illustrated in FIGS. 12A and 12B, the locking plate 163 has a closed pedal 166 instead of an opening. Further, the fingers or tangs 162 extend all the way around the needle 22. When the needle 22 passes through the dilator hub 155, the side hole in the needle 22 will be caught by the fingers or tangs 162 irrespective of whether the needle 22 is rotated relative to the dilator hub 155.

In this embodiment, the locking plate 163 is inserted in the dilator hub 155 before the needle 22 is axially inserted into the dilator hub 155. Since the fingers or tangs 155 extend entirely around the needle 22, a sheath or mandrel temporarily covers the side hole in the needle 22 to allow the needle 22 to be assembled through the dilator hub 155. Once assembled, the sheath or mandrel is removed from the needle 22.

FIGS. 13A-13D are enlarged views of perimeter shapes that the locking plate 157(a)-(c) can have in accordance with additional embodiments of the present invention. Any of the perimeter shapes illustrated in FIGS. 13A-D can be added to any of the locking plates 159, 161, 163. Of course the perimeter shapes are not limited to the illustrated embodiments. In some applications, the perimeter shape is selected to prevent the locking plate 157 from being removed from the dilator hub 155 or merely inhibit the locking plate 157 from falling out of the dilator hub 155.

The slot 158(a)-(c) in the dilator hub 155 would include corresponding shaped surfaces which engage with the perimeter shape 165, 167, 169, 171 of the locking plate to inhibit the healthcare provider from removing the locking plate from the dilator hub 155 once the locking plate 157 has been slid to the locked position. In this way, the healthcare provider is prevented from accidentally removing the locking plate and releasing the needle 22.

The embodiments herein described are comprised of conventional, biocompatible materials. For example, the needle preferably consists of a rigid polymer or a metal such as stainless steel, nitinol, or the like. The other elements can be formed of suitable polymeric materials, such as nylon, polyethylene, high-density polyethylene, polypropylene, fluoropolymers and copolymers such as perfluoro (ethylene-propylene) copolymer, polyurethane polymers or copolymers.

As noted above, the present access device can be used to place a catheter at other locations within a patient's body. Thus, for example, but without limitation, the access device can be used with a variety of catheters to drain fluids from abscesses, to drain air from a pneumothorax, and to access the peritoneal cavity. In such applications, body fluids flow into the viewing space to indicate when the needle has been properly placed.

Although this invention has been disclosed in the context of certain preferred embodiments and examples, it will be understood by those skilled in the art that the present invention extends beyond the specifically disclosed embodiments to other alternative embodiments and/or uses of the invention and obvious modifications and equivalents thereof. In addition, while a number of variations of the invention have been shown and described in detail, other modifications, which are within the scope of this invention, will be readily apparent to those of skill in the art based upon this disclosure. It is also contemplated that various combinations or subcombinations of the specific features and aspects of the embodiments may be made and still fall within the scope of the invention. Accordingly, it should be understood that various features and aspects of the disclosed embodiments can be combined with or substituted for one another in order to form varying modes of the disclosed invention. Thus, it is intended that the scope of the present invention herein disclosed should not be limited by the particular disclosed embodiments described above, but should be determined only by a fair reading of the disclosure.

What is claimed is:

- [1.** An access device for placing a medical article within a body space, comprising:
 - a needle section including an elongated needle body with a sharp distal tip and a needle hub from which the needle body extends;
 - a medical article section comprising a tubular portion and a tube hub fixed to the tubular portion, the tubular portion being coaxially disposed and slideable over the needle body with the tube hub being disposed distal of the needle hub; and
 - a locking mechanism disposed within the medical article section and selectively operating between the needle section and the medical article section, the locking mechanism being configured to move into a locked position from an unlocked position to arrest axial movement of the needle body at least in the distal direction once the distal tip of the needle body is drawn into the medical article section to protect the distal tip, wherein once in the locked position the locking mechanism is prevented from moving back to the unlocked position.]
- [2.** The access device of claim 1, wherein the locking mechanism comprises a receptacle and a tang biased toward the receptacle, the receptacle being formed on either the outer surface of the needle body or an inner surface of the tube hub, and the tang extending from the other one of the needle body outer surface and the tube hub inner surface.]
- [3.** The access device of claim 2, wherein the receptacle comprises a hole in the needle body.]
- [4.** The access device of claim 2, wherein the receptacle comprises an annular groove about the needle body.]
- [5.** The access device of claim 2 additionally comprising a second tang oriented to arrest axial movement of the needle body in a proximal direction.]
- [6.** The access device of claim 5, wherein the first and second tangs engage said receptacle when the distal tip of the needle body is sufficiently withdrawn into the medical article section.]
- [7.** The access device of claim 5, wherein the locking mechanism includes another receptacle disposed so as to receive the second tang when the distal tip of the needle body is withdrawn into the medical article section.]
- [8.** The access device of claim 2, wherein the tang is attached to the tube hub by a pivot coupling.]
- [9.** The access device of claim 2, wherein the tang is configured to move in a direction generally transverse to a longitudinal axis of the needle body when engaging the receptacle.]
- [10.** An access device for placing a medical article within a body space, comprising:
 - a dilator portion comprising a dilator and a dilator hub having a passageway configured to receive an elongated needle, the needle having at least one side hole; one or more fingers or tangs disposed in the dilator hub and configured to engage with the at least one side hole at least when the needle is retracted through the passageway, wherein the one or more fingers or tangs is prevented from moving back out of engagement with the at least one side hole.]
 - [11.** The access device of claim 10, wherein the side hole provides a passageway through which a fluid may flow.]
 - [12.** The access device of claim 10, further comprising a dilator attached to the dilator hub, the dilator comprising a side hole that can be held in alignment with the needle side hole.]
 - [13.** An access device for placing a medical article within a body space, comprising:

17

a needle section including an elongated needle body with a sharp distal tip and a needle hub from which the needle body extends;

a medical article section comprising a tubular portion and a tube hub fixed to the tubular portion, the tubular portion being coaxially disposed and slideable over the needle body with the tube hub being disposed distal of the needle hub; and

a locking mechanism disposed entirely within the medical article section and selectively operating between the needle section and the medical article section, the locking mechanism being configured to arrest axial movement of the needle body at least in the distal direction once the distal tip of the needle body is drawn into the medical article to protect the distal tip.]

[14. The access device of claim 13, wherein the locking mechanism comprises a receptacle and a tang biased toward the receptacle, the receptacle being formed on either the outer surface of the needle body or an inner surface of the tube hub, and the tang extending from the other one of the needle body outer surface and the tube hub inner surface.]

[15. The access device of claim 14, wherein the receptacle comprises a hole in the needle body.]

[16. The access device of claim 14, wherein the receptacle comprises an annular groove about the needle body.]

[17. The access device of claim 14 additionally comprising a second tang oriented to arrest axial movement of the needle body in a proximal direction.]

[18. The access device of claim 17, wherein the first and second tangs engage said receptacle when the distal tip of the needle body is sufficiently withdrawn into the medical article section.]

[19. The access device of claim 17, wherein the locking mechanism includes another receptacle disposed so as to receive the second tang when the distal tip of the needle body is withdrawn into the medical article section.]

[20. The access device of claim 14, wherein the tang is attached to the tube hub by a pivot coupling.]

[21. The access device of claim 14, wherein the tang is configured to move in a direction generally transverse to a longitudinal axis of the needle body when engaging the receptacle.]

22. *An access device for placing a medical article within a body space, comprising:*

a needle section including an elongated needle body with a sharp distal tip and a needle hub from which the needle body extends, the sharp distal tip forming an opening and the needle body comprising a side wall defining at least one side opening therein;

a medical article section comprising a tubular portion and a tube hub fixed to the tubular portion, the tubular portion being coaxially disposed and slideable over the needle body with the tube hub being disposed distal of the needle hub; and

a locking mechanism disposed within the medical article section and selectively operating between the needle section and the medical article section, the locking mechanism being configured to move into a locked position from an unlocked position to arrest axial movement of the needle body at least in the distal direction once the distal tip of the needle body is drawn into the medical article section to protect the distal tip, wherein once in the locked position the locking mechanism is prevented from moving back to the unlocked position, wherein the locking mechanism is configured to rotate into the locked position from the unlocked

18

position once the distal tip of the needle body is drawn into the medical article section.

23. *An access device for placing a medical article within a body space, comprising:*

a needle section including an elongated needle body with a sharp distal tip and a needle hub from which the needle body extends, the sharp distal tip forming an opening and the needle body comprising a side wall defining at least one side opening therein;

a medical article section comprising a tubular portion and a tube hub fixed to the tubular portion, the tubular portion being coaxially disposed and slideable over the needle body with the tube hub being disposed distal of the needle hub; and

a locking mechanism disposed within the medical article section and selectively operating between the needle section and the medical article section, the locking mechanism being configured to move into a locked position from an unlocked position to arrest axial movement of the needle body at least in the distal direction once the distal tip of the needle body is drawn into the medical article section to protect the distal tip, wherein once in the locked position the locking mechanism is prevented from moving back to the unlocked position, wherein the locking mechanism is configured to move into the locked position from the unlocked position to arrest axial movement of the needle body, relative to the medical article section, in both a proximal direction and the distal direction once the distal tip of the needle body is drawn into the medical article section.

24. *An access device for placing a medical article within a body space, comprising:*

a needle section including an elongated needle body with a sharp distal tip and a needle hub from which the needle body extends, the sharp distal tip forming an opening and the needle body comprising a side wall defining at least one side opening therein;

a medical article section comprising a tubular portion and a tube hub fixed to the tubular portion, the tubular portion being coaxially disposed and slideable over the needle body with the tube hub being disposed distal of the needle hub; and

a locking mechanism disposed entirely within the medical article section and selectively operating between the needle section and the medical article section, the locking mechanism being configured to arrest axial movement of the needle body at least in the distal direction once the distal tip of the needle body is drawn into the medical article section to protect the distal tip, wherein the locking mechanism is configured to rotate into a locked position from an unlocked position once the distal tip of the needle body is drawn into the medical article section.

25. *An access device for placing a medical article within a body space, comprising:*

a needle section including an elongated needle body with a sharp distal tip and a needle hub from which the needle body extends, the sharp distal tip forming an opening and the needle body comprising a side wall defining at least one side opening therein;

a medical article section comprising a tubular portion and a tube hub fixed to the tubular portion, the tubular portion being coaxially disposed and slideable over the needle body with the tube hub being disposed distal of the needle hub; and

a locking mechanism disposed entirely within the medical article section and selectively operating between the needle section and the medical article section, the locking mechanism being configured to arrest axial movement of the needle body at least in the distal direction once the distal tip of the needle body is drawn into the medical article section to protect the distal tip, wherein the locking mechanism is configured to arrest axial movement of the needle body, relative to the medical article section, in both a proximal direction and the distal direction once the distal tip of the needle body is drawn into the medical article section.

* * * * *