



(12) **United States Patent**
Danis et al.

(10) **Patent No.:** **US 12,089,791 B2**
(45) **Date of Patent:** ***Sep. 17, 2024**

(54) **DISPENSING ASSEMBLY FOR PAPER PRODUCTS**

(71) Applicant: **Christopher J. Danis**, Centerville, OH (US)

(72) Inventors: **Christopher J. Danis**, Centerville, OH (US); **Matthew J. Vallo**, Dayton, OH (US); **Gabrielle M. Jackson**, Dayton, OH (US)

(*) Notice: Subject to any disclaimer, the term of this patent is extended or adjusted under 35 U.S.C. 154(b) by 0 days.
This patent is subject to a terminal disclaimer.

(21) Appl. No.: **18/377,603**

(22) Filed: **Oct. 6, 2023**

(65) **Prior Publication Data**

US 2024/0032740 A1 Feb. 1, 2024

Related U.S. Application Data

(63) Continuation of application No. 18/111,628, filed on Feb. 20, 2023, now Pat. No. 11,812,897.

(60) Provisional application No. 63/392,240, filed on Jul. 26, 2022, provisional application No. 63/312,041, filed on Feb. 20, 2022.

(51) **Int. Cl.**
A47K 10/38 (2006.01)
A47K 10/32 (2006.01)

(52) **U.S. Cl.**
CPC *A47K 10/38* (2013.01); *A47K 2010/3233* (2013.01); *A47K 2010/3266* (2013.01)

(58) **Field of Classification Search**

CPC *A47K 2010/3681*; *A47K 10/38*; *A47K 10/426*; *A47K 2010/3206*; *A47K 2010/3286*; *A47K 2010/3233*; *A47K 2010/3266*
USPC 221/33-63, 197
See application file for complete search history.

(56) **References Cited**

U.S. PATENT DOCUMENTS

5,697,577 A * 12/1997 Ogden *A47K 10/38*
242/596.8
5,897,074 A * 4/1999 Marino *A47K 10/38*
242/596.8
7,887,005 B2 * 2/2011 Troutman *A47K 10/36*
242/563.2
11,051,663 B1 * 7/2021 Danis *A47K 10/3612*
11,812,897 B1 * 11/2023 Danis *A47K 10/36*
2007/0034638 A1 * 2/2007 Zeiron *A47K 10/427*
221/52
2010/0314429 A1 * 12/2010 Troutman *A47K 10/36*
225/11

(Continued)

Primary Examiner — Timothy R Waggoner

(74) *Attorney, Agent, or Firm* — Frost Brown Todd LLP; Vance V. VanDrake, III; Alexander J. Johnson

(57) **ABSTRACT**

A dispensing assembly is disclosed herein. The dispensing assembly includes a housing comprising a plurality of side panels, a cartridge for dispensing a paper product; and actuation subassembly being disposed in the housing, the actuation subassembly configured to advance the paper product disposed in the cartridge; and a slidable drawer subassembly. The slidable drawer subassembly including a cartridge tray for removably receiving the cartridge, the slidable drawer subassembly being displaceable between a closed position where the cartridge is enclosed within the housing and an open position where the cartridge is able to be loaded or unloaded from the cartridge tray.

20 Claims, 14 Drawing Sheets

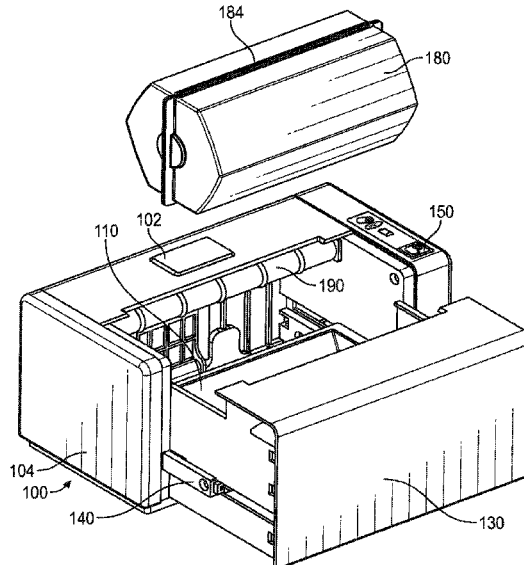

(56)

References Cited

U.S. PATENT DOCUMENTS

2013/0105614	A1*	5/2013	Hjort	A47K 10/36 242/564.5
2013/0213995	A1*	8/2013	Horel	A47K 10/424 221/197
2014/0076916	A1*	3/2014	Boyce	A47K 10/3827 221/34
2015/0196174	A1*	7/2015	Goltz	A47K 10/426 242/596

* cited by examiner

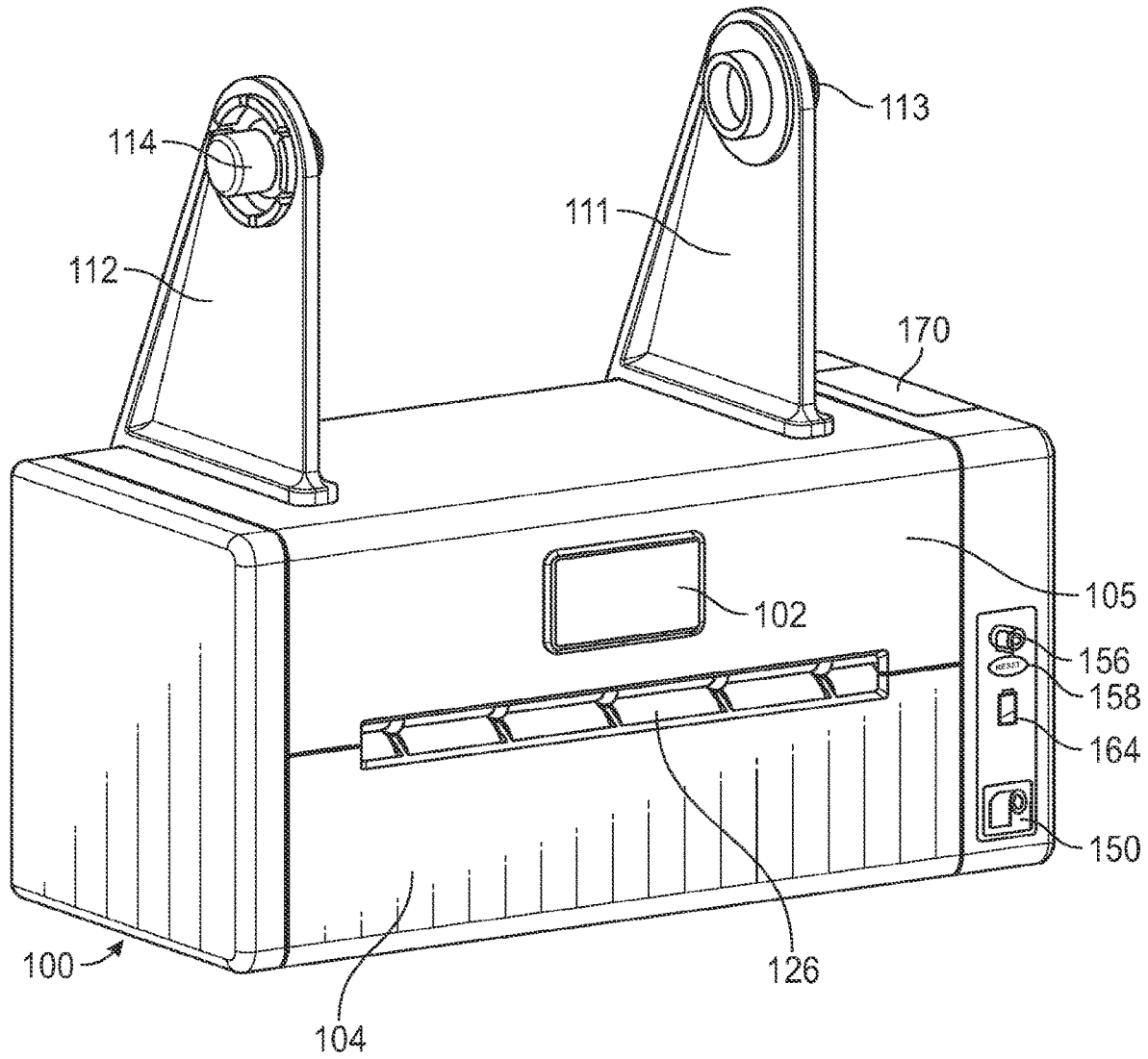

FIG. 1A

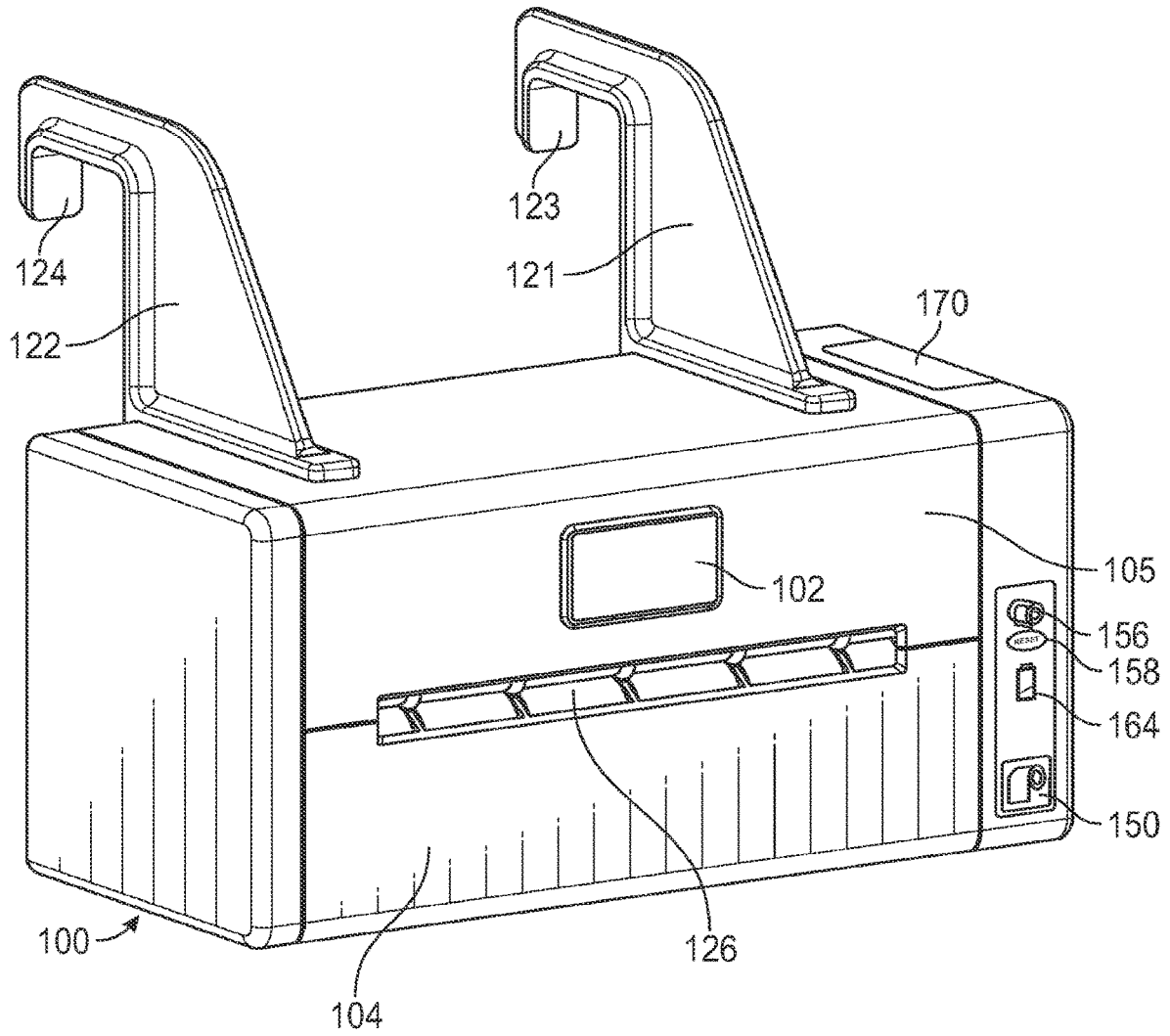

FIG. 1B

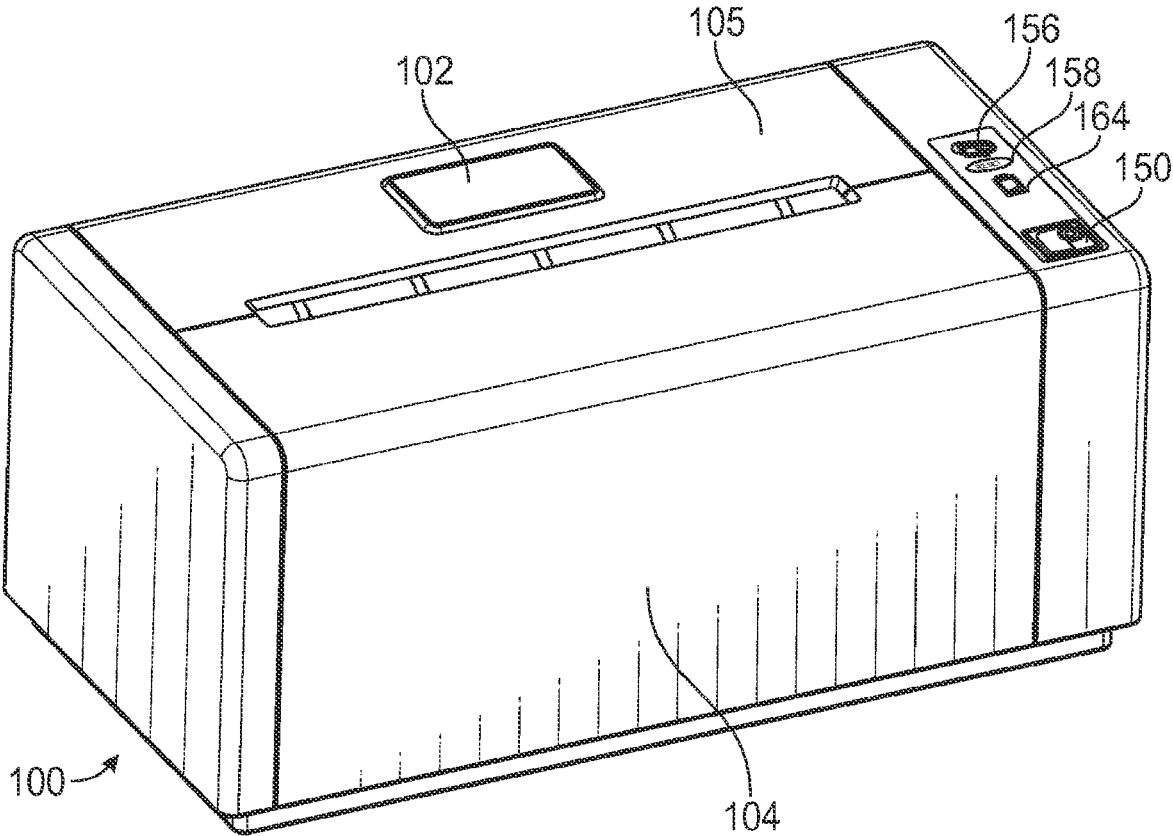

FIG. 2

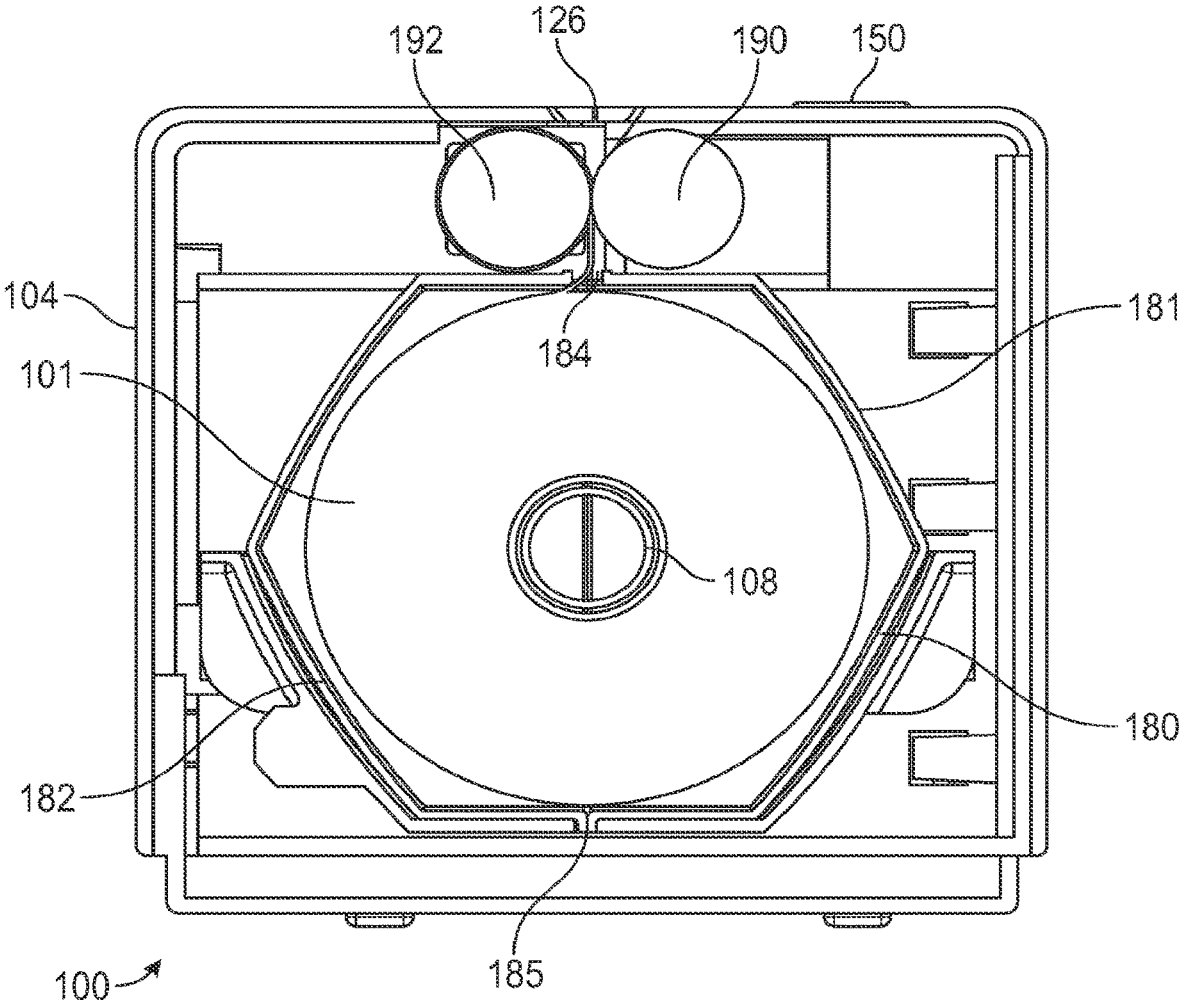

FIG. 3

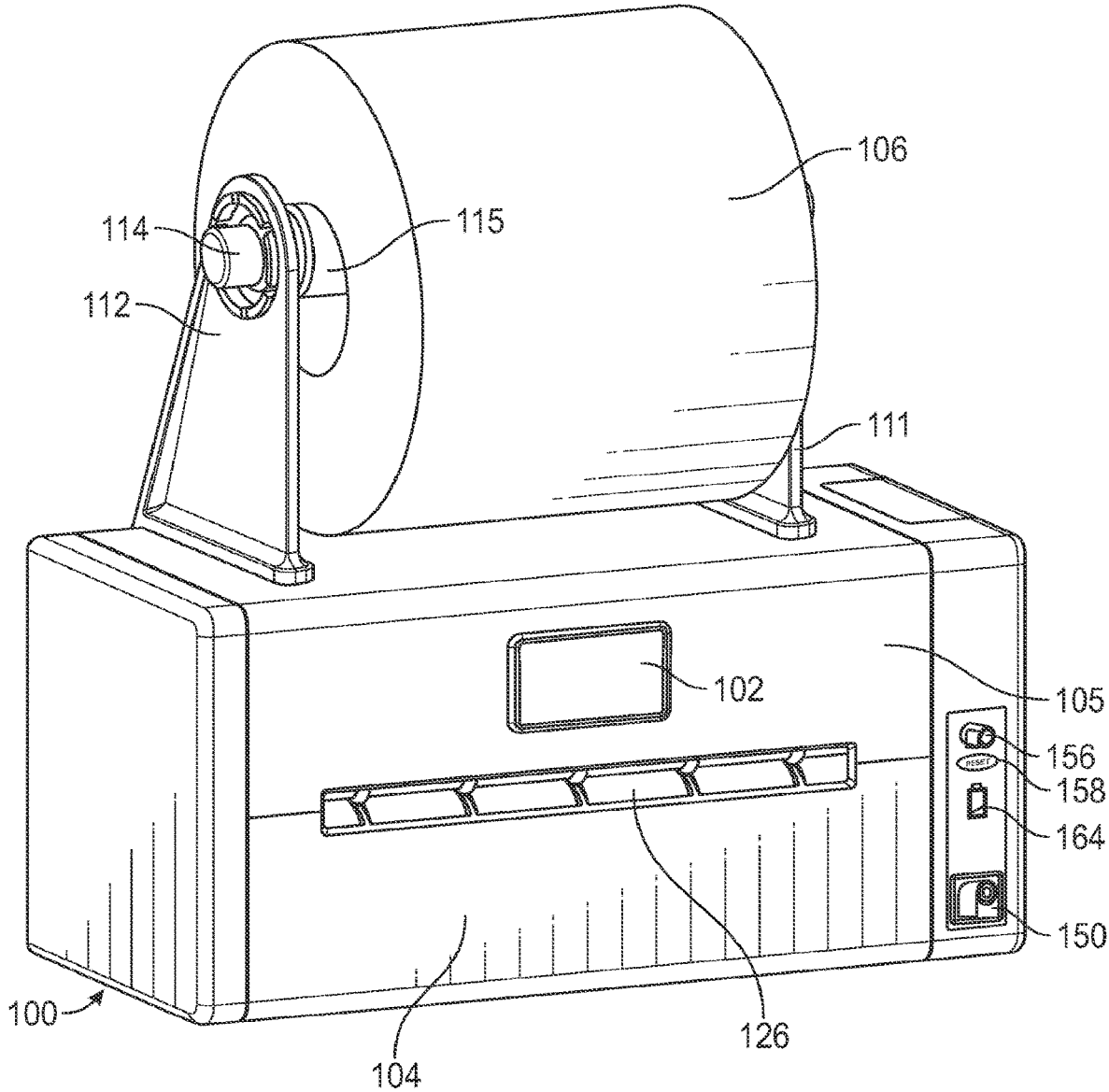

FIG. 4

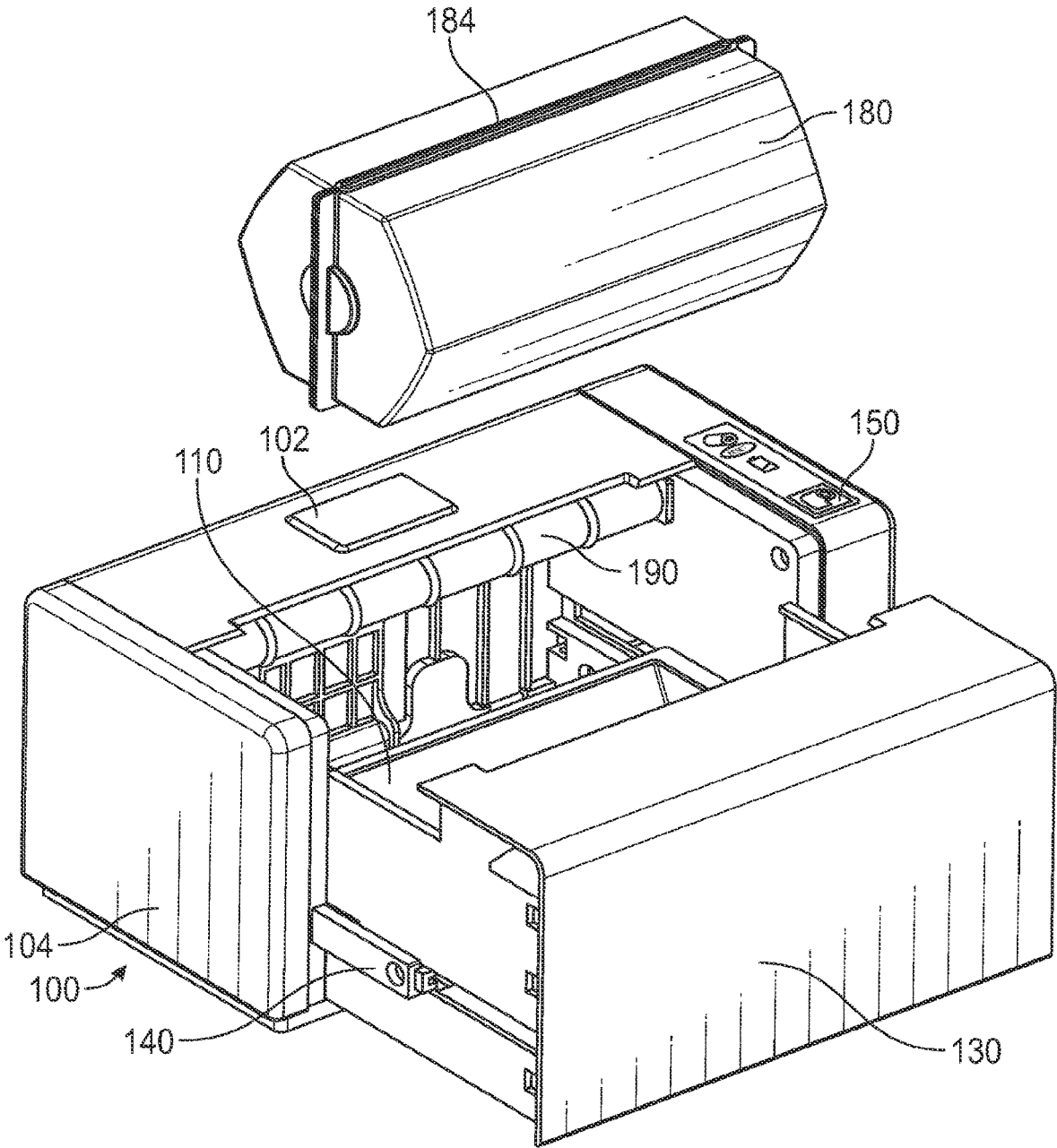

FIG. 5

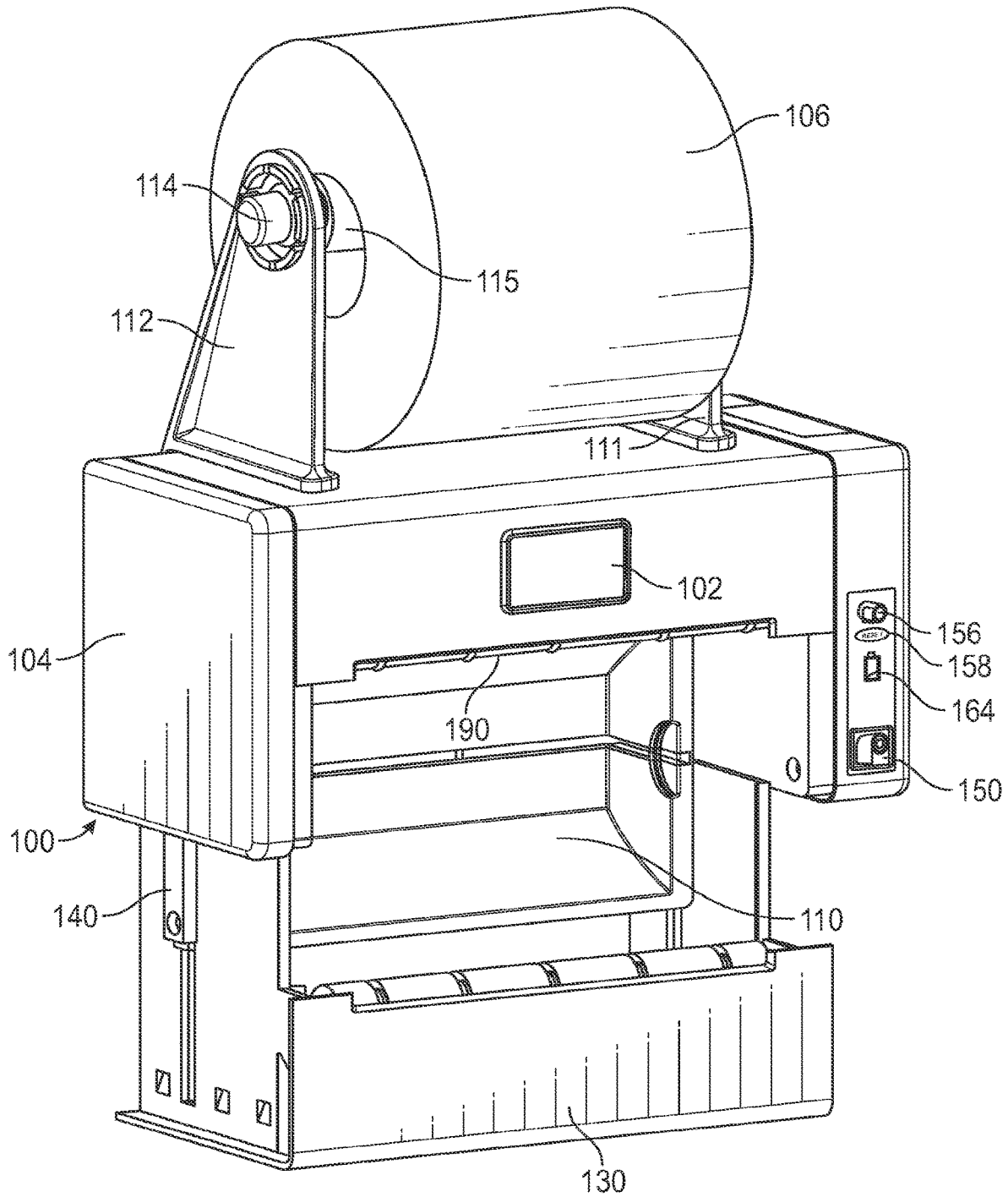

FIG. 6

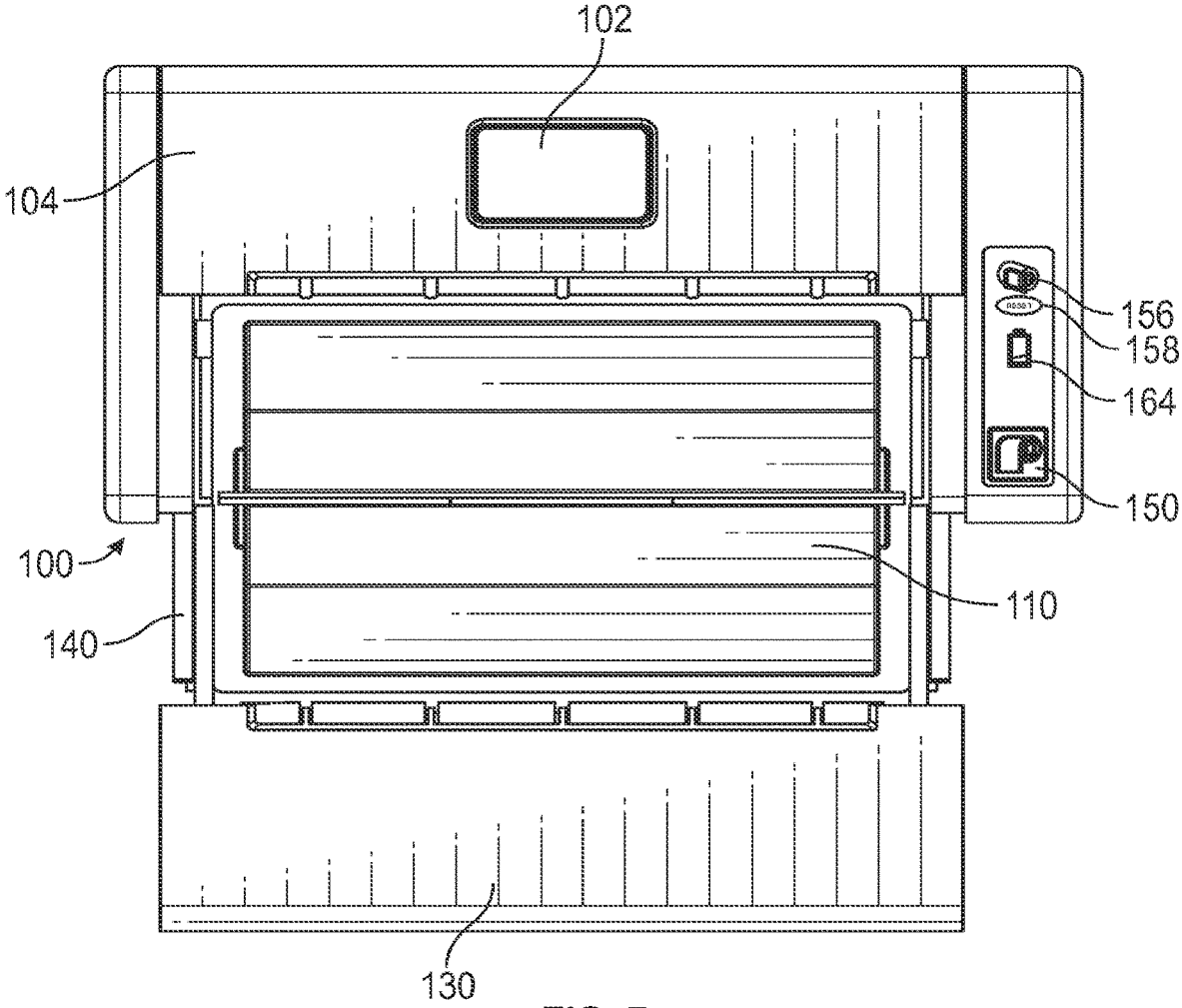

FIG. 7

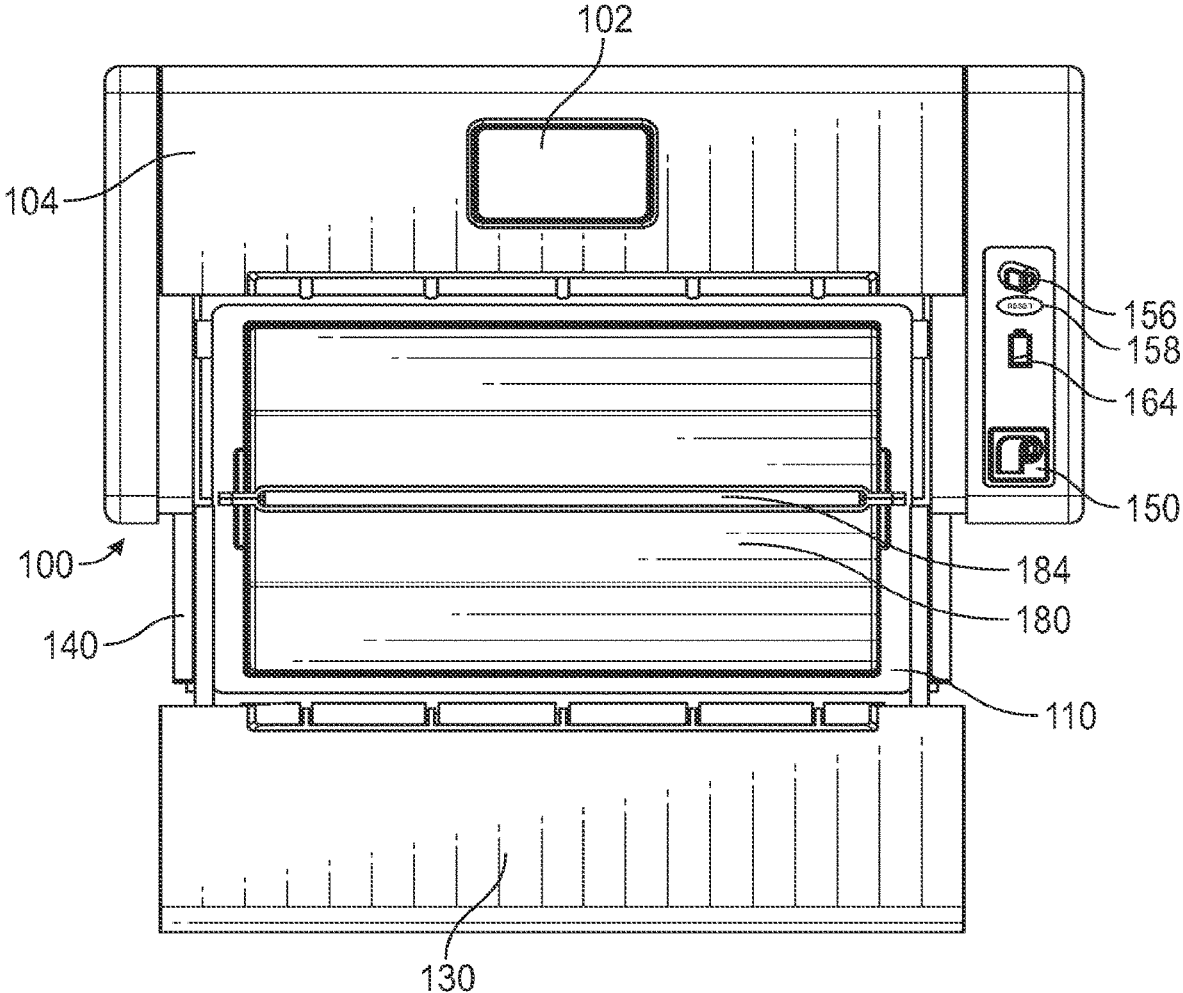

FIG. 8

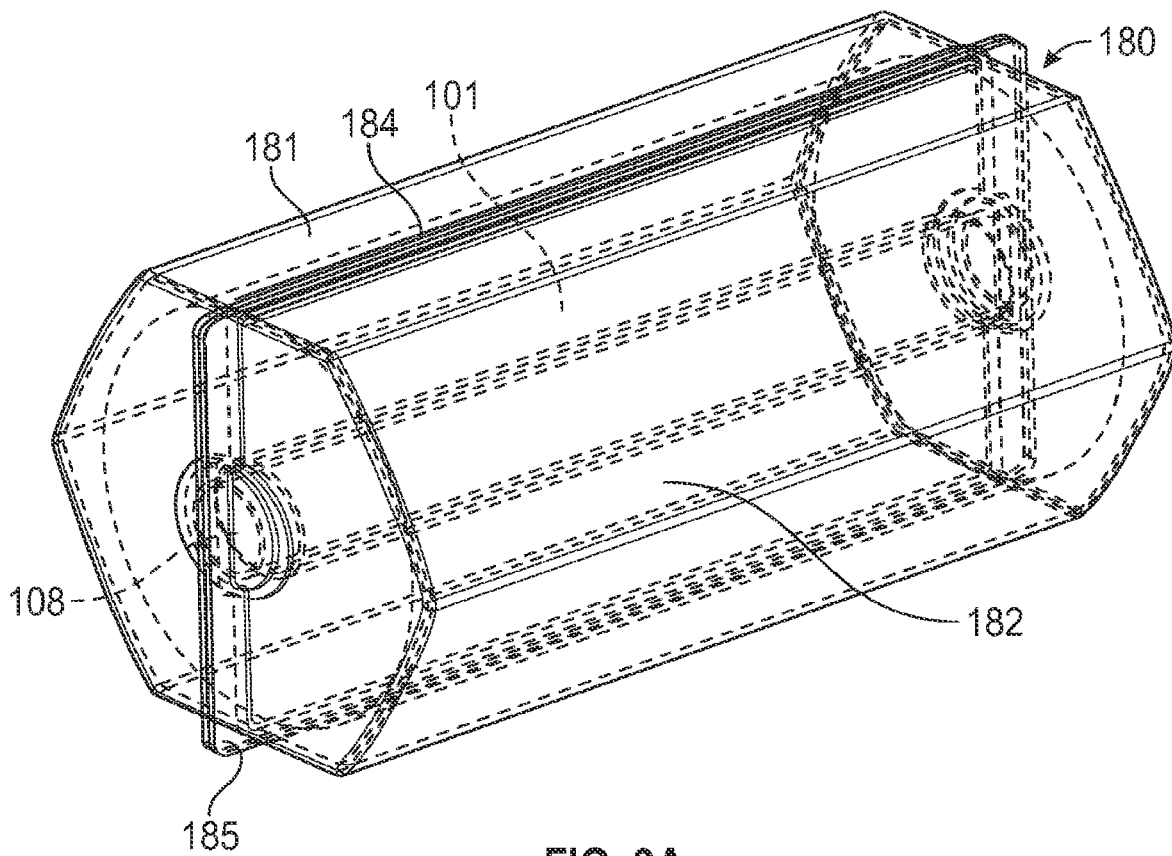

FIG. 9A

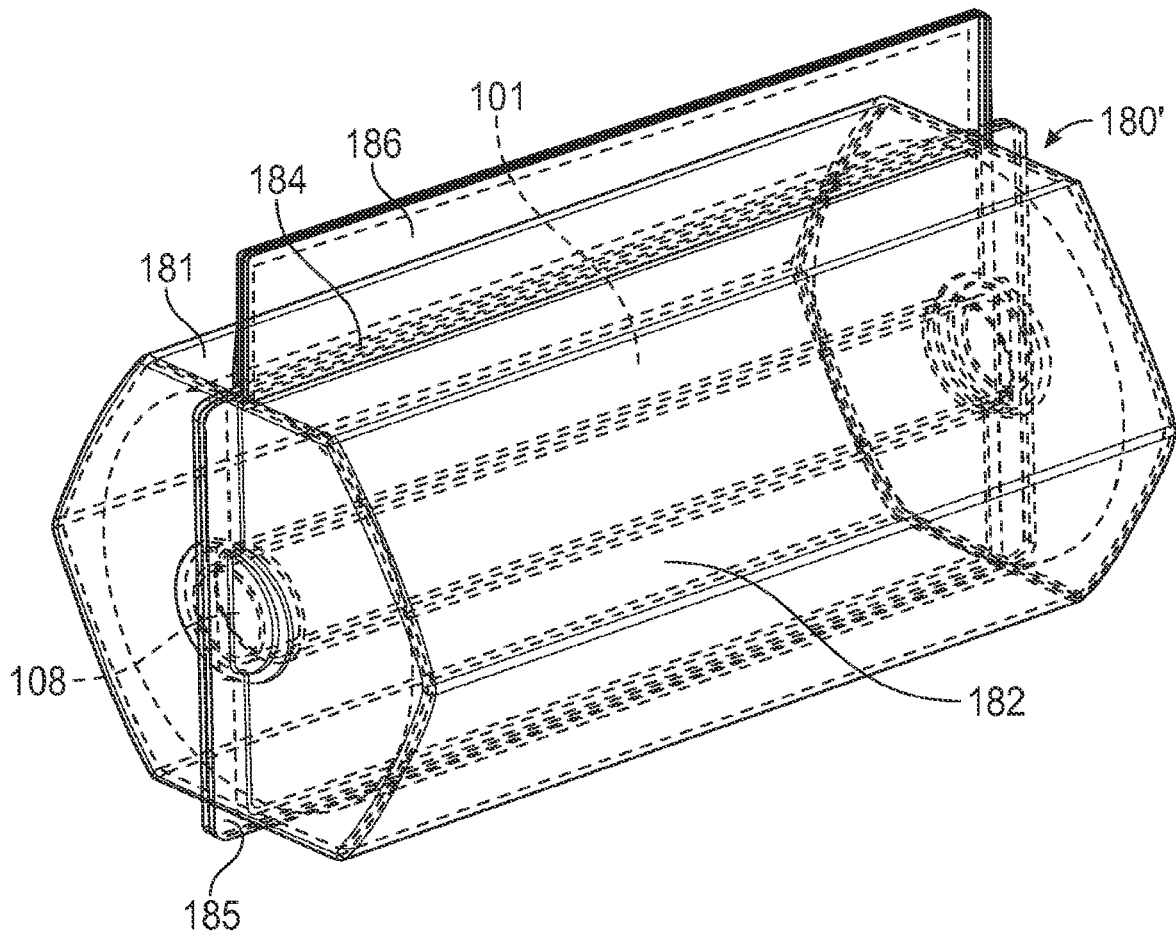

FIG. 9B

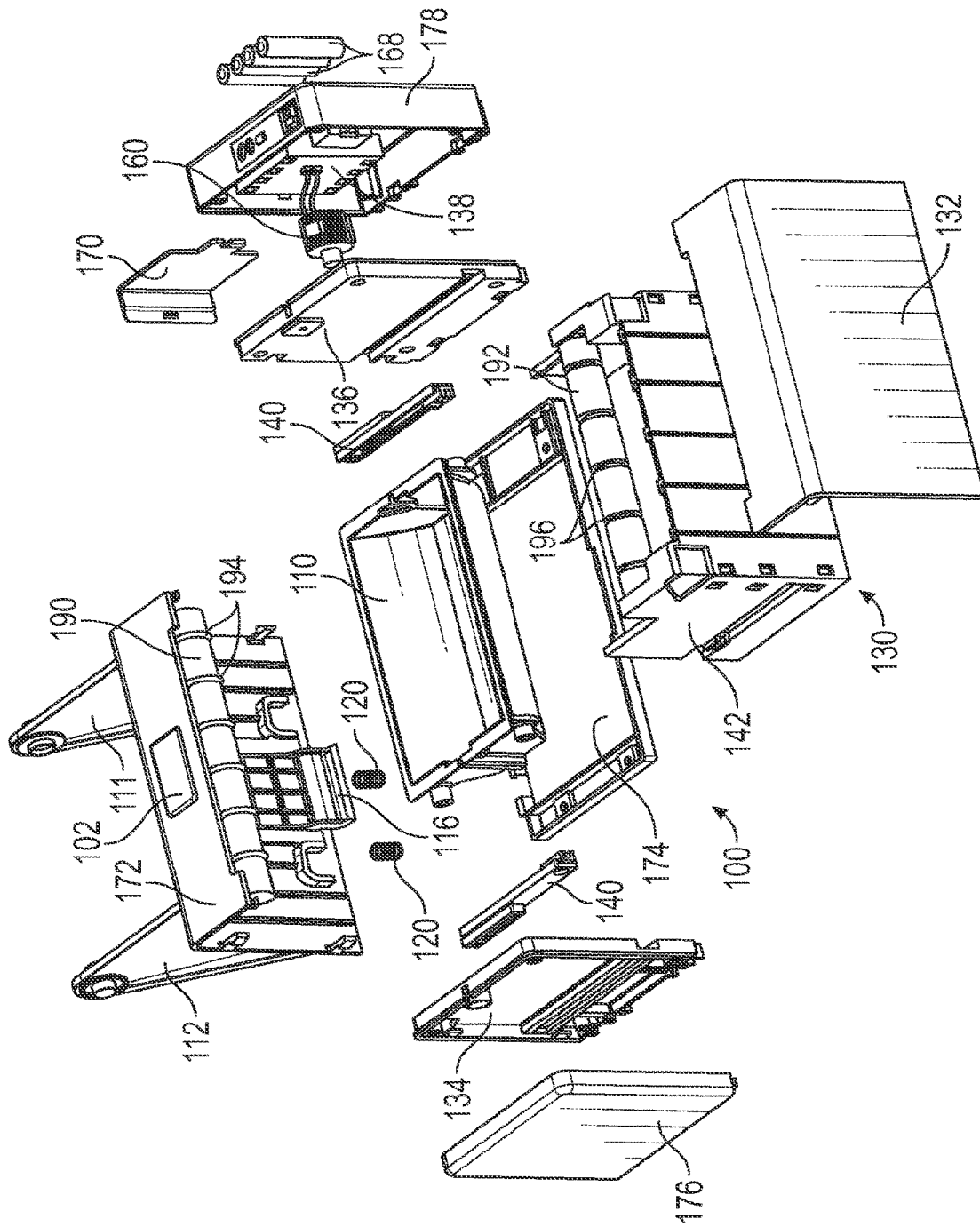

FIG. 10A

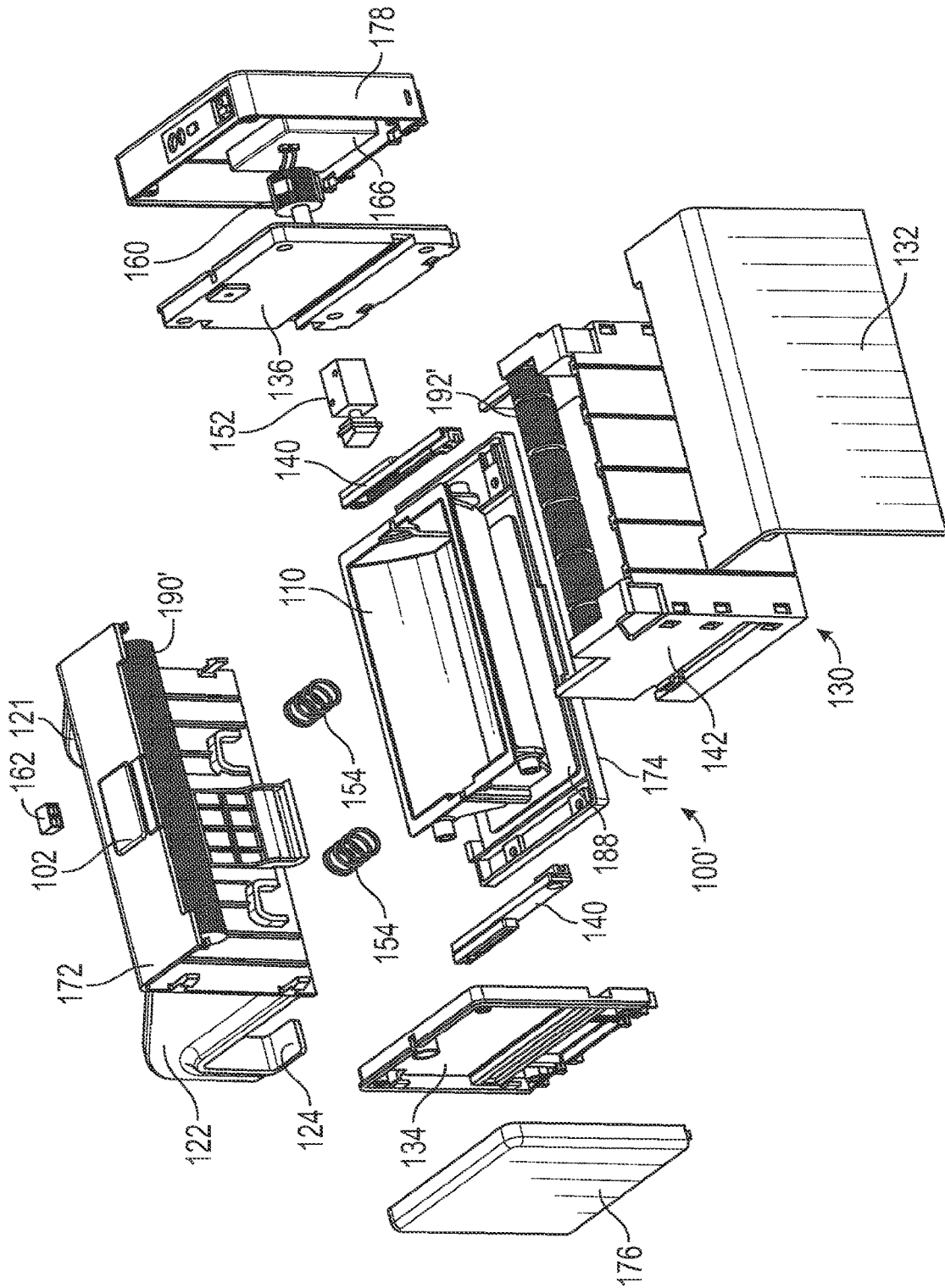

FIG. 10B

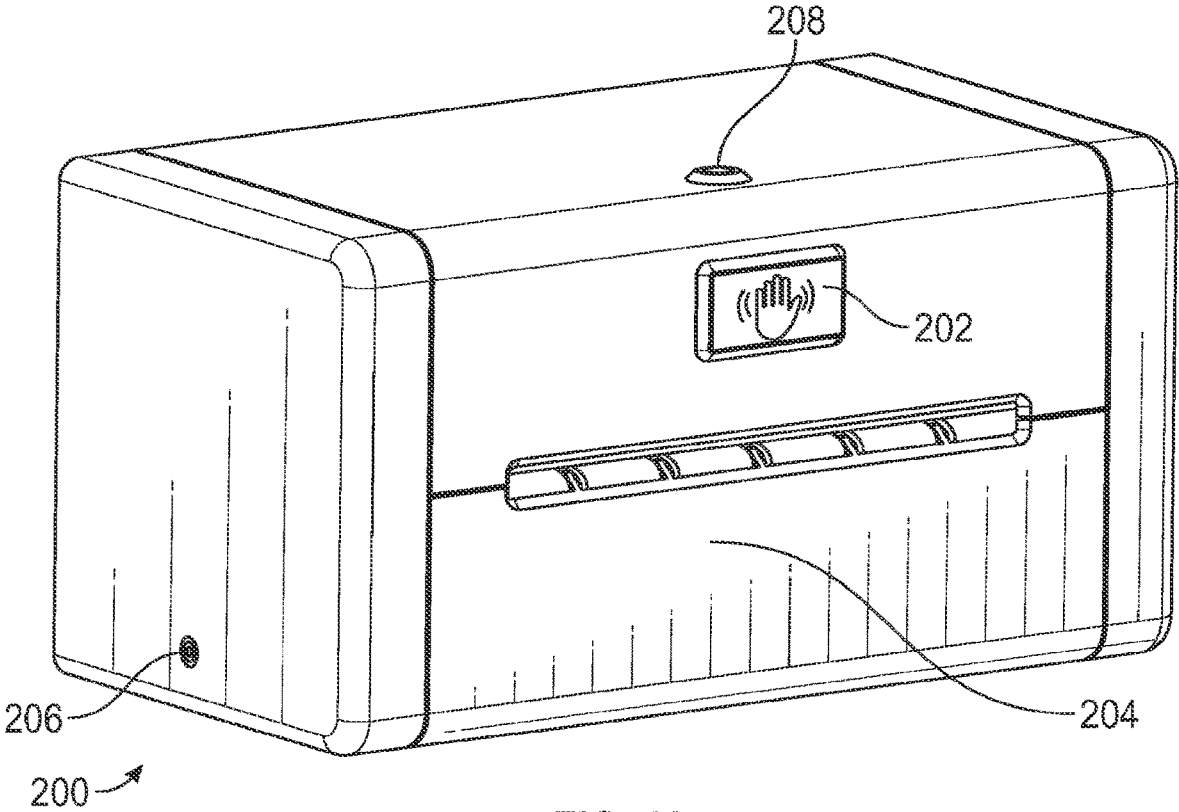

FIG. 11

1

DISPENSING ASSEMBLY FOR PAPER PRODUCTS

CROSS-REFERENCE TO RELATED APPLICATIONS

This is a continuation of U.S. patent application Ser. No. 18/111,628, filed Feb. 20, 2023, which claims priority to U.S. Provisional Patent Application No. 63/312,041, entitled “Dispensing Assembly For Paper Products”, filed on Feb. 20, 2022, and U.S. Provisional Patent Application No. 63/392,240, entitled “Dispensing Assembly For Paper Products”, filed on Jul. 26, 2022, the disclosure of each of which is hereby incorporated by reference as if set forth in its entirety herein.

FIELD OF INVENTION

The present invention relates to a dispensing assembly for paper products and, more specifically, to a housing and a cartridge for dispensing pre-wetted paper products.

BACKGROUND

Many conventional combination dispensers for wet and dry paper products (e.g., toilet paper) occupy excessive amounts of space and do not provide convenient access to both the wet and dry paper products. In addition, current dispensers often do not allow for easy replacement or replenishment of the wet paper products by the consumer and fail to provide a barrier to loss of moisture from the wet paper products. Furthermore, some dispensers require installation of special-purpose holders, and dispensers that attach to existing wall-mounted holders may still require modification of the holder, the wall, or other adjacent structure to accommodate the dispenser. Many of these conventional dispensers are not recyclable or may contain one or more components that are not recyclable.

BRIEF SUMMARY OF EMBODIMENTS OF THE INVENTION

Accordingly, the present disclosure is directed to a dispensing assembly for paper products that substantially obviates one or more problems resulting from the limitations and deficiencies of the related art.

In accordance with one or more embodiments of the present disclosure, there is provided a dispensing assembly that includes a housing comprising a plurality of side panels; a cartridge for dispensing a paper product; an actuation subassembly being disposed in the housing, the actuation subassembly configured to advance the paper product disposed in the cartridge; and a slidable drawer subassembly, the slidable drawer subassembly including a cartridge tray for removably receiving the cartridge, the slidable drawer subassembly being displaceable between a closed position where the cartridge is enclosed within the housing and an open position where the cartridge is able to be loaded or unloaded from the cartridge tray. In a further embodiment of the present disclosure, the slidable drawer subassembly further comprises a double slide mechanism for allowing the cartridge tray to be displaced between the closed position and the open position.

In yet a further embodiment, when the slidable drawer subassembly is moved into the closed position, one or more rollers of the dispensing assembly are configured to compress the paper product dispensed from the cartridge.

2

In still a further embodiment, the dispensing assembly further comprises an active roller and a passive roller, the active roller being driven by the actuation subassembly, and the passive roller being spring-loaded so as to compress the paper product between the passive roller and the active roller.

In yet a further embodiment, the passive roller further comprises a plurality of spaced-apart grooves formed therein, each of the plurality of spaced-apart grooves being configured to receive a respective tooth member in the active roller to facilitate a reliable dispensing of the paper product.

In still a further embodiment, the dispensing assembly further comprises a mechanical release button for opening the slidable drawer subassembly of the dispensing assembly, the mechanical release button being operatively coupled to a spring-loaded mechanical latching device such that a depressing of the mechanical release button releases the spring-loaded mechanical latching device for allowing the slidable drawer subassembly to open.

In yet a further embodiment, the cartridge further comprises a first portion and a second portion, the first portion of the cartridge being hingedly connected to the second portion.

In still a further embodiment, the actuation subassembly comprises a drive gear and a drive motor, the drive gear being operatively coupled to the drive motor and to an active roller in the housing, and when a button is depressed on the housing, the drive gear and the active roller rotate a pre-defined rotational distance to advance the paper product.

In yet a further embodiment, the dispensing assembly further comprises a hanger component attached to the housing, the hanger component comprising a pair of arms that suspend the housing below a spindle.

In still a further embodiment, the hanger component comprises a plurality of attachment protrusions that are configured to snap into corresponding recesses formed in the housing so as to removably attach the hanger component to the housing.

In yet a further embodiment, the cartridge is configured to be inserted into a front of the housing by means of the slidable drawer subassembly.

In still a further embodiment, the paper product comprises cleaning wipes disposed on a roll.

In yet a further embodiment, the actuation subassembly comprises a drive gear, a drive motor, and a membrane switch pad, the drive gear being operatively coupled to the drive motor and to an active roller in the housing, the membrane switch pad comprising a first switch for rotating the drive gear and the active roller a predefined rotational distance so as to advance the paper product, a first indicator light for indicating a low battery condition of the dispensing assembly, a second indicator light for indicating a low sheet count of the paper product, and a second switch for resetting a wipe count to zero when a new cartridge is inserted into the dispensing assembly by a user.

In still a further embodiment, the dispensing assembly further comprises a sensor device configured to detect a portion of a sheet of the paper product after a prior sheet of the paper product has been torn off by a user, and cause the drive motor to reverse until no portion of the sheet is detected by the sensor device, thereby allowing for a smallest amount of sheet surface of the sheet to be exposed to air so as to reduce moisture loss from the sheet when the sheet has been pre-moistened.

In yet a further embodiment, the dispensing assembly further comprises an encoder provided on the drive motor to measure a number of revolutions of the active roller, an

output signal of the encoder being used to indicate when to stop the drive motor from rotating so as to result in a sheet of the paper product being positioned correctly, thereby facilitating a proper detachment of the sheet for use.

In still a further embodiment, the dispensing assembly is configured to be mounted to a surface of a support structure, and the drive motor of the dispensing assembly is configured to be powered by a low voltage power source or a 120-volt building power source.

In yet a further embodiment, the dispensing assembly further comprises an electrical release button for opening the slidable drawer subassembly of the dispensing assembly, the electrical release button being operatively coupled to a solenoid latching device such that a depressing of the electrical release button releases a solenoid pin of the solenoid latching device for allowing the slidable drawer subassembly to open, the solenoid latching device configured to be powered by the low voltage power source or the 120-volt building power source.

In still a further embodiment, the dispensing assembly further comprises a heating element for heating the paper product in the cartridge, the heating element being mounted on one of the plurality of side panels of the housing next to the cartridge tray, and the heating element configured to be powered by the low voltage power source or the 120-volt building power source.

In yet a further embodiment, the dispensing assembly further comprises a touchless actuator or switch for dispensing the paper product from the dispensing assembly; and, when a user places his or hand in close proximity to the touchless actuator or switch, an active roller of the dispensing assembly is configured to be rotated a predefined rotational distance so as to advance the paper product, and dispense the paper product from the dispensing assembly.

In still a further embodiment, the cartridge comprises a cartridge extension portion extending outwardly a cartridge dispensing slot of the cartridge, the cartridge extension portion acting as a guide for the proper positioning of a leading edge of a first sheet of the paper product so as to set the proper positioning for the successive sheets of the paper product, and the cartridge extension portion being perforated so as to allow the cartridge extension portion to be separated from a remainder of the cartridge after the leading edge of the first sheet of the paper product has been properly positioned.

It is to be understood that the foregoing general description and the following detailed description of the present disclosure are merely exemplary and explanatory in nature. As such, the foregoing general description and the following detailed description of the present disclosure should not be construed to limit the scope of the appended claims in any sense.

BRIEF DESCRIPTION OF THE SEVERAL VIEWS OF THE DRAWINGS

While the specification concludes with claims particularly pointing out and distinctly claiming the present invention, it is believed that the present invention will be better understood from the following description in conjunction with the accompanying Drawing Figures, in which like reference numerals identify like elements, and wherein:

FIG. 1A is a front-top perspective view of a first illustrative embodiment of a dispensing assembly comprising a housing and a cartridge in accordance with principles of the present disclosure, wherein a first suspended configuration of the dispensing assembly is illustrated;

FIG. 1B is another front-top perspective view of the dispensing assembly of FIG. 1A, wherein a second suspended configuration of the dispensing assembly is illustrated;

FIG. 2 is another front-top perspective view of the dispensing assembly of FIG. 1A, wherein a tabletop configuration of the dispensing assembly is illustrated;

FIG. 3 is a transverse sectional perspective view of the dispensing assembly of FIG. 2;

FIG. 4 is yet another front-top perspective view of the dispensing assembly of FIG. 1A, wherein the first suspended configuration of the dispensing assembly is illustrated with a toilet paper roll and spindle;

FIG. 5 is a partially exploded view of the dispensing assembly of FIG. 2, where the slidable drawer subassembly of the housing is open, and the cartridge has been removed from the housing;

FIG. 6 is another perspective view of the dispensing assembly of FIG. 1A, wherein the slidable drawer subassembly of the housing is open so that a cartridge is able to loaded into the cartridge tray of the slidable drawer subassembly;

FIG. 7 is a top plan view of the dispensing assembly of FIG. 2, wherein the slidable drawer subassembly of the housing is open so that a cartridge is able to loaded into the cartridge tray of the slidable drawer subassembly;

FIG. 8 is another top plan view of the dispensing assembly of FIG. 2, wherein the slidable drawer subassembly of the housing is open, and a cartridge has been loaded into the cartridge tray of the slidable drawer subassembly;

FIG. 9A is a perspective view of a cartridge of the dispensing assembly of FIG. 1A, wherein a roll of a paper product is disposed in the cartridge, and a cartridge extension portion of the cartridge has been removed;

FIG. 9B is another perspective view of the cartridge of FIG. 9A prior to the cartridge extension portion of the cartridge having been removed, wherein a roll of a paper product is disposed in the cartridge;

FIG. 10A is an exploded perspective view of the dispensing assembly of FIG. 2;

FIG. 10B is an exploded perspective view of a second illustrative embodiment of a dispensing assembly comprising a housing and a cartridge in accordance with principles of the present disclosure; and

FIG. 11 is a front-top perspective view of a third illustrative embodiment of a dispensing assembly comprising a housing and a cartridge in accordance with principles of the present disclosure, wherein a large tabletop configuration of the dispensing assembly is illustrated.

Throughout the figures, the same parts are always denoted using the same reference characters so that, as a general rule, they will only be described once.

DETAILED DESCRIPTION OF EMBODIMENTS OF THE INVENTION

In the following detailed description of the preferred embodiments, reference is made to the accompanying drawings that form a part hereof, and in which is shown by way of illustration, and not by way of limitation, specific preferred embodiments in which the invention may be practiced. It is to be understood that other embodiments may be utilized and that changes may be made without departing from the spirit and scope of the present invention.

With reference to FIGS. 1A, 3, 4, and 5, a dispensing assembly 100 in accordance with a first illustrative embodiment of the present disclosure is depicted. The dispensing

assembly **100** comprises a housing **104** and a cartridge **180**. The housing **104** and the cartridge **180** may each comprise one or more polymeric materials and may comprise at least partially recycled and/or recyclable materials. The housing **104** may comprise a plurality of side panels that together define a compartment into which the cartridge **180** is removably received, as described herein. The housing **104** may comprise an elongate body portion **105** (see FIGS. 1A, 2, 5, and with the plurality of side panels **132**, **172**, **174** and a pair of end caps **176**, **178** on opposed ends of the elongate body portion **105**. As shown in FIG. 10A, the side panels **132**, **172**, **174** of the housing **104** comprise an L-shaped front wall **132**, an L-shaped rear wall **172**, and a bottom wall **174**. The dispensing assembly **100** may further comprise an actuation subassembly being disposed in the housing (see FIG. 5), the actuation subassembly being configured to advance the paper product **101** disposed in the cartridge **180**.

Referring again to FIGS. 1A, 4, and 6, it can be seen that the dispensing assembly **100** may further comprise a first type of hanger subassembly. The first type of hanger subassembly is attached to the top of the housing **104** (see FIGS. 1A and 4), and the first type of hanger subassembly comprises a pair of arms **111**, **112** that may suspend the housing **104** below a spindle (e.g., a toilet paper roll core **115**). The pair of arms **111**, **112** extend upwardly in a generally perpendicular manner from an upper surface of the housing **104**. The first arm **111** comprises a first attachment protrusion **113** and the second arm **112** comprises a second attachment protrusion **114** for hanging the dispensing assembly **100** from a toilet paper holder. Also, as shown in FIG. 1A, first arm **111** comprises an interior cradle for receiving a first end of the spindle **115**, while the second arm **112** comprises an interior cradle for receiving a second oppositely disposed end of the spindle **115**. As shown in FIGS. 4 and 6, the toilet tissue roll **106** may be placed on the spindle **115** and supported above the housing **104**.

In the illustrative embodiment, the first attachment protrusion **113** may be part of a first removable insert and the second attachment protrusion **114** may be part of a second removable insert (e.g., the removable inserts have resilient prongs for snapping into the respective apertures in the arms **111**, **112**). The removable inserts allow the hanger subassembly to accommodate different configurations of toilet paper holders. For example, when the removable inserts are removed from the arms **111**, **112**, the hanger subassembly is able to accommodate an L-shaped toilet paper holder.

In the illustrative embodiment, each of the arms **111**, **112** of the first type of hanger subassembly may comprise a plurality of attachment protrusions (e.g., a pair of attachment protrusions) that are configured to snap into corresponding recesses formed in the housing **104** so as to removably attach the hanger subassembly to the housing **104**.

Turning to FIG. 1B, in the illustrative embodiment, it can be seen that the dispensing assembly **100** may further comprise a second type of hanger subassembly. Like the first type of hanger subassembly, the second type of hanger subassembly is attached to the top of the housing **104** (see FIG. 1B), and the second type of hanger subassembly comprises a pair of arms **121**, **122** that may suspend the housing **104** below a tabletop (e.g., the tabletop of a baby changing table). The pair of arms **121**, **122** extend upwardly in a generally perpendicular manner from an upper surface of the housing **104**. The first arm **121** comprises a first hook portion **123** and the second arm **122** comprises a second hook portion **124** for hanging the dispensing assembly **100** from the edge of a tabletop. For example, the first and

second hook portions **123**, **124** may be attached to a standard baby changing table by hooking onto the edge of the changing table.

In the illustrative embodiment, similar to the first type of hanger subassembly, each of the arms **121**, **122** of the second type of hanger subassembly may comprise a plurality of attachment protrusions (e.g., a pair of attachment protrusions) that are configured to snap into corresponding recesses formed in the housing **104** so as to removably attach the hanger subassembly to the housing **104**.

As shown in FIGS. 1A, 4, and 6, the first configuration of the dispensing assembly **100** comprises the first and second arms **111**, **112** for suspending the housing **104** below a toilet paper roll spindle, while the third configuration of the dispensing assembly **100** is designed to rest on a support surface (e.g., a tabletop surface—see FIG. 2). In the illustrative embodiment, the dispensing assembly **100** may be provided with a plurality of support feet (e.g., four (4) polymeric pads) in each corner on the bottom of the housing **104** for allowing the dispensing assembly **100** to rest on a tabletop, countertop, changing table, or other horizontal surface.

With reference to FIG. 9A, the cartridge **180** comprises a first portion **181** and a second portion **182**. In the illustrative embodiment, the first portion **181** may be coupled to the second portion **182** in a clamshell-type configuration. More particularly, in the illustrative embodiment, the first portion **181** may be coupled to the second portion **182** by a hinge **185** extending longitudinally along the elongate rear side of the cartridge **180**. The hinge **185** may be integrally formed with the cartridge **180** (i.e., be in the form of a living hinge), or may comprise a strip of thin, flexible material adhered to the cartridge **180** and spanning between the first portion **181** and the second portion **182**. The first portion **181** of the cartridge **180** may pivot along the hinge **185** to allow access to an interior space of the cartridge **180**.

The cartridge **180** may be for dispensing a paper product **101**, as shown in FIG. 3. The cartridge **180** may accommodate a variety of wet paper products and may be refillable. The paper product **101** may comprise, for example, a rolled, continuous sheet of a pre-wetted paper product, such as a personal wipe (commonly referred to as a wet wipe or moist towelette), which may be disposable and/or flushable (i.e., may be flushed down a toilet for disposal with other solid waste). Alternatively, the paper product **101** may comprise non-flushable wipes for tabletop use. The paper product **101** may comprise a line of weakness or perforations that define individual sheets. In some embodiments, the cartridge **180** is in the form of a self-contained cartridge where the cartridge **180** completely houses the pre-wetted paper product roll **101**. The self-contained cartridge **180** may have the paper product roll **101** preloaded therein as a single use item that contains approximately fifty (50) flushable wipes or baby wipes, or the paper product roll may also be reloaded by the user (i.e., to replace an empty paper product roll **101**).

Also, as shown in FIG. 9A, the cartridge **180** further comprises a roller core **108** on which the paper product roll **101** is supported. The opposed ends of the roller core **108** are received within opposed semi-circular notches in the first portion **181** of the cartridge **180** and opposed semi-circular notches in the second portion **182** of the cartridge **180**.

In the illustrative embodiment, when the cartridge **180** is refillable, to install the paper product roll **101** in the cartridge **180**, the first portion **181** of the cartridge **180** is opened and the paper product **101** is placed into the cartridge **180**. A first sheet of the rolled paper product **101** is inserted through an

opening **184** in the cartridge **180** such that the sheet extends outward from the top or side of the cartridge **180**.

An initial state of the cartridge is illustrated in FIG. 9B. The cartridge **180'** of FIG. 9B is similar in most respects to the cartridge **180** of FIG. 9A, except that FIG. 9B depicts the initial state of the cartridge prior to cartridge extension portion **186** having been removed. In the illustrative embodiment, the cartridge extension portion **186** is made up of two sides, one from the first portion **181** of the cartridge and the other side from the second portion **182** of the cartridge. The illustrative cartridge extension portion **186** has micro-perforations which allows the cartridge extension portion **186** to be separated from the cartridge, therefore, exposing the slot **184** where the wipe exits the cartridge. The initial wet wipe is trapped between the two sides of cartridge extension portion **186** and will be dispensed, thus setting the correct height for the successive wet wipes on the roll. In other words, the cartridge extension portion **186** depicted in FIG. 9B facilitates the positioning of the leading edge of the first wipe at the correct height. The cartridge extension portion **186** maintains the leading edge of the dispensed wipe at a predetermined height so that the wipe is able to be pulled through the rollers **190**, **192** and dispensed accurately. As such, the design of the cartridge **180'** with the cartridge extension portion **186** advantageously enables the initial wipe height to be accurately set.

As shown in the illustrative embodiment of FIGS. 5-8 and 10A, the dispensing assembly **100** further comprises a slidable drawer subassembly **130**. In FIGS. 5-7, it can be seen that the slidable drawer subassembly **130** includes a cartridge tray **110** for removably receiving the cartridge **180**. Also, as shown in FIGS. 10A and 10B, it can be seen that the slidable drawer subassembly **130** comprises a drawer frame **142**. The slidable drawer subassembly **130** is displaceable between a closed position where the cartridge **180** is enclosed within the housing **104** and an open position where the cartridge **180** is able to be loaded or unloaded from the cartridge tray **110**. Also, as shown in the exploded view of FIG. 10A, the slidable drawer subassembly **130** comprises the L-shaped front wall **132** disposed on the drawer frame **142**, and the compartment of the dispensing assembly **100** that receives the slidable drawer subassembly **130** is bounded on opposed ends by the first and second interior partition walls **134**, **136**.

Turning again to FIGS. 5 and 6, it can be seen that the slidable drawer subassembly **130** further comprises a double action slide mechanism **140** for allowing the cartridge tray **110** to be displaced between the closed position and the open position. In the illustrative embodiment, the double action slide mechanism **140** allows for the cartridge tray **110** to move independently from the drawer. The primary purpose of the double action slide mechanism **140** is so that the cartridge tray **110** can move into a position where the cartridge **180** can freely drop in. This feature allows for the least amount of opening for placement of the cartridge **180** into the cartridge tray **110**. In the illustrative embodiment, the double action slide mechanism **140** comprises a pair of telescoping rails on each side of the drawer **130** for enabling the drawer **130** to extend out further than the depth dimension of the drawer **130**. In the illustrative embodiment, referring to FIGS. 3 and 5, the dispensing assembly **100** further comprises an active roller **190** and a passive roller **192**. In the illustrative embodiment, the active roller **190** is driven by the actuation subassembly, and the passive roller **192** is spring-loaded (e.g., by two springs) so as to compress the paper product between the passive roller **192** and the active roller **190**. When the slidable drawer subassembly **130**

is moved into the closed position, the passive roller **192** of the dispensing assembly **100** compresses the paper product **101** dispensed from the cartridge **180** against the active roller **190** such that the active roller **190** and the passive roller **192** together form a seal across the slot through which the paper product **101** is dispensed. This seal may be partially watertight, which helps to reduce loss of moisture from the paper product **101**. Compression of the paper product **101** between the active roller **190** and the passive roller **192** also helps to prevent retraction or withdrawal of the paper product **101** back through a housing slot **126** and into the cartridge **180**. As described in more detail herein, the active roller **190** and the passive roller **192** cooperate to dispense sheets (e.g., one dispensed sheet at a time) of the paper product **101** via the cartridge opening **184** and aligned housing slot **126** in the front or top of the housing **104** (see FIGS. 1A and 3).

In the illustrative embodiment, the passive roller **192** may be in a form of a grooved passive roller that accepts protrusions or teeth to enhance the dispensing of the paper product **101**. For example, as shown in FIG. 10A, in these one or more embodiments, the passive roller **192** may be injection molded with a series of small annular grooves or indentations **196** spaced apart along the length of the passive roller **192**. The small grooves or indentations **196** between the sections of the roller **192** allow for small annular protrusions or teeth **194** on the active roller **190** to fit inside the grooves (see FIG. 10A). In the illustrative embodiment, the rounded protuberances **194** on the active roller **190** create tongues which match the grooves **196** in the passive roller **192** so as to assist in the reliable dispensing of wet wipes (refer to FIG. 10A).

In one or more alternative embodiments, protrusions or teeth may be molded in the housing **104** of the unit **100**. This construction of the dispensing assembly **100** is similar to a "tongue and groove" configuration used in other applications. Advantageously, in these one or more alternative embodiments, the protrusions or teeth elevate the paper product **101** off the passive roller **192** as the unit **100** is dispensing. This prevents the paper product **101** from rolling around the roller **192**, thereby increasing the reliability of the unit **100**. In one or more alternative embodiments, the dispensing assembly **100** may comprise protrusions or teeth on the edge of the lower-case side that interface with the grooved passive roller **192**.

In the illustrative embodiment, as shown in FIGS. 1A, 2, and 4-6, the dispensing assembly **100** further comprises a release button **102** for opening the slidable drawer subassembly **130** of the dispensing assembly **100**. The release button **102** is operatively coupled to the slidable drawer subassembly **130** such that a depressing of the release button **102** compresses springs **120** in FIG. 10A and releases the latch **116**, thereby enabling the slidable drawer subassembly **130** to open.

Referring to the exploded view of FIG. 10A, it can be seen that the release button **102** is operatively coupled to the drawer release mechanism **116**. In the illustrative embodiment, the drawer release mechanism **116** comprises a spring-loaded latch that holds the slidable drawer subassembly **130** in the closed position. Pushing inwardly on the release button **102** disengages the latch, which allows the drawer **130** to open. The button **102** and the latch **116** are separate pieces and get screwed together, plus there are pieces to hold the latch in place and contain small springs **120**. Downward pressure on the button **102** causes a downward displacement, compressing of the springs **120**, and releasing of the latch **116** such that the drawer **130** is able to open. In the

illustrative embodiment, the springs **120** maintain the release mechanism **116** in the engaged, latched position until the release button **102** is pressed by a user.

With reference to FIG. 5, a portion of the housing **104** adjacent to the housing compartment may further comprise an actuator compartment that encloses the various components of the actuation subassembly. The actuator compartment may be defined on five sides by the housing **104**, and on a sixth side by the housing interior wall **136**. In the illustrative embodiment, the actuator compartment is disposed on the end of the housing with actuation button **150**.

Now, with reference to FIGS. 3 and 5, the actuation subassembly of the dispensing assembly **100** will be described in detail. In the illustrative embodiment, the actuation subassembly may comprise a drive gear (e.g., a spur gear), a gear box, and a direct drive electric motor **160** (see e.g., FIG. 10A, the drive gear and gear box may be provided as part of the motor assembly **160**). The drive gear may be operatively coupled to the direct drive motor **160** via the gear box, which adjusts the rotational output (i.e., the speed and torque) of the direct drive motor **160**. In turn, the drive gear is operatively coupled to the active roller **190**. When the actuation button **150** (see e.g., FIGS. 1A and 2) is depressed on the front of the housing **104**, the drive gear and the active roller **190** rotate a predefined rotational distance to advance the paper product **101**. In the illustrative embodiment, the actuation subassembly may further comprise a control board disposed in the housing **104** for the controlling the operation of the actuation subassembly.

In the first illustrative embodiment, the direct drive motor **160** is electrically powered by batteries **168** (e.g., four (4) disposable AA size batteries **168**), which are located in a battery compartment **138** of the housing **104** (see FIG. 10A) and are accessible for replacement by means of a removable battery compartment door **170**.

The electronic control circuit of the control board performs various functions in the illustrative embodiment of the dispensing assembly **100**. First, the electronic control circuit of the control board results in the dispensing of exactly one pre-moistened wipe from the internal cartridge **180** for each press of the actuation button **150**. Secondly, the electronic control circuit of the control board turns off the drive motor **160** at the correct time so that the perforation on the wipe product generally aligns with the dispensing slot **126**. This allows the dispensed product to easily be retrieved by the user by separating the single dispensed wipe from the device. In the illustrative embodiment, the electronic control circuit may be implemented using commercially available electronics components on a custom printed circuit board (PCB). The circuit design utilizes common analog and digital design techniques. Logic control may be achieved using a microcontroller with custom software, digital logic timer/counter integrated circuits, or a combination of these.

In the illustrative embodiment, when a user presses the actuation button **150** with his or her finger on the front of the housing **104** (see e.g., FIGS. 1A and 2), a control signal is sent to the control board. Upon the depressing of the button **150**, the control circuit in the control board turns the drive motor **160** on and also starts a timer. The timer's expiration time is pre-programmed to be slightly longer than the typical time required to dispense a single wet wipe.

In the illustrative embodiment, the actuation button **150** may be in a form of a microswitch on a membrane switch pad. The membrane switch pad may have a plurality of different functions and/or indicators that are used on the dispensing assembly **100**. In the illustrative embodiment, the membrane switch pad with the actuation button **150** has four

functions that may include: (i) dispense wipe by depressing button **150**, (ii) low battery indicator **164** (see e.g., indicator light **164** in FIGS. 1A and 2), (iii) low wipe indicator **156** (see e.g., indicator light **156** in FIGS. 1A and 2), and (iv) device reset (see e.g., reset button **158** in FIGS. 1A and 2). The first function may be performed by an activation switch on the membrane switch pad that powers up the electric motor **160**, which moves the active roller **190**. The second function may be performed by a low battery indicator light emitting diode (LED) **164** on the membrane switch pad. The third function may be performed by a low wipe count LED indicator **156** on the membrane switch pad, which is illuminated based upon a determination of the number of revolutions that the active roller **190** has moved through. In the illustrative embodiment, the control board of the dispensing assembly **100** uses a signal from an encoder on the motor **160** to determine the number of wipes dispensed, and thus illuminates the low wipe count LED indicator **156** when number of wipes is determined to be low. The fourth function may be performed by a reset switch or button **158** on the membrane switch pad which is used to zero out the wipe count and bring the number back to zero when a new cartridge **180** is inserted into the device **100** by the user. The encoder on the motor **160** counts the number of revolutions of the active roller **190**. The encoder counts the revolutions and stops the motor **160** when the number of revolutions equals a single wet wipe. The total number of revolutions is counted and when 95% of the wipes are dispensed, the LED indicator **156** will light up indicating a low wipe count.

In one or more embodiments, when the drive motor **160** is activated by the control circuit in the control board, the drive motor **160** rotates the gear box components, which in turn, rotates the drive gear. Rotation of the drive gear causes the active roller **190** to rotate a corresponding rotational distance. This rotation of the active roller **190** causes the sheet of the rolled or stacked paper product **101** extending from the slot **126** to move outwardly from the housing **104**. In this manner, sheets of the paper product **101** are dispensed one at a time from the cartridge **180**. Compression of the paper product **101** between the active roller **190** and the passive roller **192** keeps the paper product **101** from retracting back into the cartridge **180** between depressions of the actuation button **150**. Upon depletion of the paper product **101**, the cartridge **180** may be removed from the housing **104** as described herein for refilling or disposal (see FIG. 5).

In one or more alternative embodiments, rather than the actuation button **150** being in a form of a microswitch on a membrane switch pad, the actuation button **150** may be a single electromechanical actuation button where the pressing of the actuation button by the user depresses a microswitch which, in turn, powers up the electric motor **160**, and thereby moves the active roller **190**.

In a second illustrative embodiment, with reference to FIG. 10B, rather using the mechanical release button **102** for opening the slidable drawer subassembly **130**, the dispensing assembly **100'** is provided with a solenoid release device **152**. The drawer release function may be performed by an electrical release button **102** on the front or top of the housing **104**, which when pressed by a user, sends an electrical signal to the solenoid release device **152** that results in the release of a solenoid pin, thereby causing the slidable drawer subassembly **130** of the unit **100** to open. When solenoid pin is released, the slidable drawer subassembly **130** is unlatched, and spring forces exerted by the large springs **154** are able to push the drawer **130** open (see FIG. 10B). That is, the drawer **130** is spring-loaded such that the springs **154** assist in the opening of the drawer **130** once

11

an electrical release button is pressed by a user, and the solenoid pin is released. In the second illustrative embodiment, this electrical release feature replaces the mechanical release button **102** and release mechanism **116** of the drawer **130** described above for the first embodiment, thereby allowing the release to be electrically activated instead of mechanically activated.

In the second illustrative embodiment, with reference again to FIG. **10B**, the dispensing assembly **100'** may further comprise an infrared reader/sensor **162** to facilitate the controlled dispensing of an individual sheet of the paper product **101** (e.g., a single wet wipe). In these one or more embodiments, the function of the sensor **162** is to detect a portion of a sheet after the prior sheet is torn off by the consumer and cause the motor **160** to reverse until no portion of the subsequent sheet is detected. This allows for the smallest amount of sheet surface to be exposed to air, thereby reducing moisture loss for a moistened sheet (e.g., a wet wipe). As such, in the illustrative embodiment, the motor **160** is in the form of a bidirectional motor that is electrically coupled to the infrared reader/sensor **162** so that proper substrate height can be consistently present after each dispensing. Also, the infrared reader/sensor **162** may be configured to detect the appropriate height of the leading edge of the sheet substrate. In these one or more embodiments, the infrared sensor may have a configuration that is similar to infrared sensor **256** described in commonly owned U.S. Pat. No. 11,051,663, the disclosure of which is hereby incorporated by reference in its entirety.

In the second illustrative embodiment, rather than being powered by the disposable batteries **168**, the direct drive motor **160** of the dispensing assembly **100'** is electrically powered by a rechargeable battery pack **166**, which is located in the end cap **178** of the housing **104** (see FIG. **10B**). A charging port is provided on the exterior of the end cap **178** that receives the plug of a charging cord for charging the rechargeable battery pack **166**. The low battery indicator light emitting diode (LED) **164** described above may be used with the rechargeable battery pack **166** in the same manner described above for the disposable batteries **168** and may be configured to illuminate when a low voltage state of the rechargeable battery pack **166** occurs.

In the second illustrative embodiment, as shown in FIG. **10B**, the dispensing assembly **100'** may further comprise a warming tray for heating the paper product **101** in the cartridge **180**. For example, as depicted in FIG. **10B**, a thin metal sheet **188** may be attached to the interior top surface of the bottom wall **174** for operating as a resistance heating element for heating the cartridge **180**. The thin metal sheet **188** may be electrically coupled to the low voltage source of the dispensing assembly **100'** for creating a constant low temperature heat source for the purpose of warming the cartridge **180** and the paper product **101** disposed therein.

In the second illustrative embodiment, rather than being provided with rollers **190**, **192** having the tongue and groove arrangement described above for the first illustrative embodiment, the active roller **190'** and the passive roller **192'** are in a form of gear drive rollers (see FIG. **10B**) that matingly engage with one another in a gear-like manner. As shown in FIG. **10B**, the active roller **190'** has elongated teeth that interface with corresponding teeth on the passive roller **192'**. The gear-type configuration of the active and passive rollers **190'**, **192'** of the dispensing assembly **100'** in the second illustrative embodiment eliminates the compression aspect of the rollers so the fluid in substrate **101** is maintained on dispensing.

12

In one or more embodiments, the dispensing assembly **100** may further comprise an encoder on the electric motor to measure the number of revolutions of the active roller **190**. The encoder then stops the motor from rotating so as to result in the single sheet (e.g., wet wipe) being positioned correctly, thereby allowing the detachment of the sheet (e.g., wet wipe) for use. Based on the length of the sheet (e.g., wet wipe), the number of revolutions of the active roller **190** can be controlled by the encoder.

Now, with reference to FIG. **11**, a dispensing assembly **200** in accordance with a third illustrative embodiment of the present disclosure is depicted. In the third illustrative embodiment, for commercial applications of the dispensing assembly **200**, the size of both the cartridge tray and the unit **200** itself may be enlarged. For example, the cartridge of the unit **200** may be designed to accept a roll of the paper product (e.g., a roll of wet wipes) where each sheet on the roll is approximately 6.5 inches wide by approximately 7 inches long. In this further embodiment, the number of individual sheets is increased to one hundred (100) sheets or wipes per cartridge with the increased size of the cartridge. To accommodate the larger cartridge size, the dispensing unit **200** is increased in size, and is powered by low voltage or standard 120-volt building power instead of battery power. For example, as shown in FIG. **11**, the dispensing assembly **200** may be provided with a power port or receptacle **206** for receiving a plug of a low voltage power cord or a standard 120-volt building power cord. The low voltage power source or standard 120-volt building power may be used to power the electric motor **160**, the solenoid release device **152**, and the wipe warming device **188** described above, rather than the rechargeable battery pack **166** or the disposable batteries **168**. In this further embodiment, the enlarged unit is designed to be directly mounted on a surface with direct wiring. Unlike the embodiment described above, this larger, commercial version of the dispensing assembly **200** is not designed to be hung from a spindle (e.g., a toilet paper roll core). When standard 120-volt building power is used for powering the dispensing unit **200**, a step-down transformer/rectifier may be included to reduce the incoming voltage and/or convert the incoming alternating current (AC) to direct current (DC).

Referring again to FIG. **11**, it can be seen that, in the third illustrative embodiment, the front of the housing **204** is provided with a touchless actuator or switch **202** for dispensing the wipe from the unit **200**, rather than the dispensing button **150** described above in conjunction with the first illustrative embodiment. In addition, as shown in FIG. **11**, the commercial embodiment of the dispensing assembly **200** may comprise a drawer locking mechanism **208** disposed on the top of the housing **204** so that the slidable drawer subassembly **130** is not able to be opened unless the user has a key. In the third illustrative embodiment, the drawer locking mechanism **208** may be in a form of a keyed switch which releases the slidable drawer **130** by activating the solenoid latch **152** described above in conjunction with FIG. **10B**. As such, in the third illustrative embodiment wherein the dispensing assembly **200** may be used for commercial applications, the slidable drawer **130** cannot be opened without a key.

In the third illustrative embodiment, the dispensing assembly **200** may incorporate many of the features described above in conjunction with the exploded view depicted in FIG. **10B**. For example, the dispensing assembly **200** may include the solenoid release device **152**, the gear-type active and passive rollers **190'**, **192'**, and the wipe warming device **188**.

A dispensing assembly in accordance with the present disclosure provides a number of advantages over known combination dispensers. For example, attachment of the dispensing assembly to a fixed substrate such as a wall-mounted, toilet tissue holder places the personal wipes within easy reach for use in combination with dry paper products such as a conventional toilet tissue roll. There is generally no need to install an additional or specific holder, especially for the dispensing assembly, as the housing can typically be installed on an existing holder. There is also generally no need to modify the existing holder, the wall, or any other adjacent structure to accommodate the dispensing assembly. The compact housing hangs below the fixed substrate to take advantage of unused space, while allowing unencumbered access to the dry paper products positioned above the compartment that receives the cartridge. The cartridge may accommodate a variety of different rolled and stacked wet paper products and provides for easy installation and removal by a consumer. The cartridge helps to prevent moisture loss in the case of a pre-wetted paper product by enclosure of the paper product on all sides and formation of a seal between the active and passive rollers near the slot from which the paper product is dispensed. The cartridge may be reusable and/or refillable, and the housing and cartridge may be recycled at the end of their life cycles.

Any of the features or attributes of the above-described embodiments and variations can be used in combination with any of the other features and attributes of the above-described embodiments and variations as desired.

Having thus described the invention of the present application in detail and by reference to embodiments thereof, it will be apparent that modifications and variations are possible without departing from the scope of the invention defined in the appended claims.

The invention claimed is:

1. A dispensing assembly, comprising:
 - a housing;
 - a cartridge configured to dispense a paper product;
 - an actuation subassembly associated with the housing, the actuation subassembly being configured to advance the paper product from the cartridge; and
 - a slidable drawer subassembly, the slidable drawer subassembly being displaceable between a closed position and an open position.
2. The dispensing assembly according to claim 1, wherein the slidable drawer subassembly includes a cartridge tray for removable receiving a cartridge and a double slide mechanism for allowing the cartridge tray to be displaced between the closed position and the open position.
3. The dispensing assembly according to claim 1, wherein, when the slidable drawer subassembly is moved into the closed position, one or more rollers of the dispensing assembly are configured to compress the paper product dispensed from the cartridge.
4. The dispensing assembly according to claim 1, wherein the dispensing assembly further comprises an active roller and a passive roller, wherein the active roller is driven by the actuation subassembly, and wherein the passive roller is spring-loaded so as to compress the paper product between the passive roller and the active roller.
5. The dispensing assembly according to claim 4, wherein the passive roller further comprises a plurality of spaced-apart grooves formed therein, each of the plurality of spaced-apart grooves being configured to receive a respective tooth member in the active roller to facilitate a reliable dispensing of the paper product.

6. The dispensing assembly according to claim 1, further comprising a mechanical release button for opening the slidable drawer subassembly of the dispensing assembly, the mechanical release button being operatively coupled to a spring-loaded mechanical latching device such that a depressing of the mechanical release button releases the spring-loaded mechanical latching device for allowing the slidable drawer subassembly to open.

7. The dispensing assembly according to claim 1, wherein the cartridge further comprises a first portion and a second portion, the first portion of the cartridge being hingedly connected to the second portion.

8. The dispensing assembly according to claim 1, wherein the actuation subassembly further comprises a drive gear, a drive motor, and a membrane switch pad, wherein the drive gear is operatively coupled to the drive motor and to an active roller in the housing, and wherein the membrane switch pad includes a first switch for rotating the drive gear and the active roller a predefined rotational distance to advance the paper product.

9. The dispensing assembly according to claim 8, wherein the actuation subassembly further comprises a second switch for resetting a wipe count to zero when a new cartridge is inserted into the dispensing assembly by a user.

10. The dispensing assembly according to claim 1, wherein the actuation subassembly further comprises a first indicator light for indicating a low battery condition of the dispensing assembly and a second indicator light for indicating a lower sheet count of the paper product.

11. The dispensing assembly according to claim 1, further comprising a hanger component attached to the housing, the hanger component comprising a pair of arms that suspend the housing below a spindle and a plurality of attachment protrusions that are configured to snap into corresponding recesses formed in the housing so as to removably attach the hanger component to the housing.

12. The dispensing assembly according to claim 1, wherein the cartridge is configured to be inserted into a front of the housing by means of the slidable drawer subassembly.

13. The dispensing assembly according to claim 1, wherein the paper product comprises cleaning wipes disposed on a roll.

14. The dispensing assembly according to claim 1, further comprising a sensor device configured to detect a portion of a sheet of the paper product after a prior sheet of the paper product has been torn off by a user, and cause a drive motor to reverse until no portion of the sheet is detected by the sensor device, thereby allowing for a smallest amount of sheet surface of the sheet to be exposed to air so as to reduce moisture loss from the sheet when the sheet has been pre-moistened.

15. The dispensing assembly according to claim 1, further comprising an encoder provided on a drive motor to measure a number of revolutions of an active roller, an output signal of the encoder being used to indicate when to stop the drive motor from rotating so as to result in a sheet of the paper product being positioned correctly, thereby facilitating a proper detachment of the sheet for use.

16. The dispensing assembly according to claim 1, wherein the dispensing assembly is configured to be mounted to a surface of a support structure, and a drive motor of the dispensing assembly is configured to be powered by a low voltage power source or a 120-volt building power source.

17. The dispensing assembly according to claim 1, further comprising an electrical release button for opening the slidable drawer subassembly of the dispensing assembly, the

15

electrical release button being operatively coupled to a solenoid latching device such that a depressing of the electrical release button releases a solenoid pin of the solenoid latching device for allowing the slidable drawer subassembly to open, the solenoid latching device configured to be powered by a low voltage power source or a 120-volt building power source.

18. The dispensing assembly according to claim 1, further comprising a heating element for heating the paper product in the cartridge, the heating element being mounted on one the housing adjacent to the cartridge tray, and the heating element configured to be powered by a low voltage power source or a 120-volt building power source.

19. The dispensing assembly according to claim 1, further comprising a touchless actuator or switch for dispensing the paper product from the dispensing assembly; wherein, when a user places his or hand in close proximity to the touchless actuator or switch, an active roller of the dispensing assembly is configured to be rotated a predefined rotational

16

distance so as to advance the paper product and dispense the paper product from the dispensing assembly.

20. A dispensing assembly, comprising:

- a housing;
- a cartridge configured to dispense a paper product;
- an actuation subassembly associated with the housing, the actuation subassembly configured to advance the paper product from the cartridge; and

wherein the cartridge comprises a cartridge extension portion extending outwardly a cartridge dispensing slot of the cartridge, the cartridge extension portion acting as a guide for the proper positioning of a leading edge of a first sheet of the paper product so as to set the proper positioning for the successive sheets of the paper product, and the cartridge extension portion being perforated so as to allow the cartridge extension portion to be separated from a remainder of the cartridge after the leading edge of the first sheet of the paper product has been properly positioned.

* * * * *