

(No Model.)

A. YOUNG.
BAG HOLDER.

No. 435,474.

Patented Sept. 2, 1890.

Fig. 1.

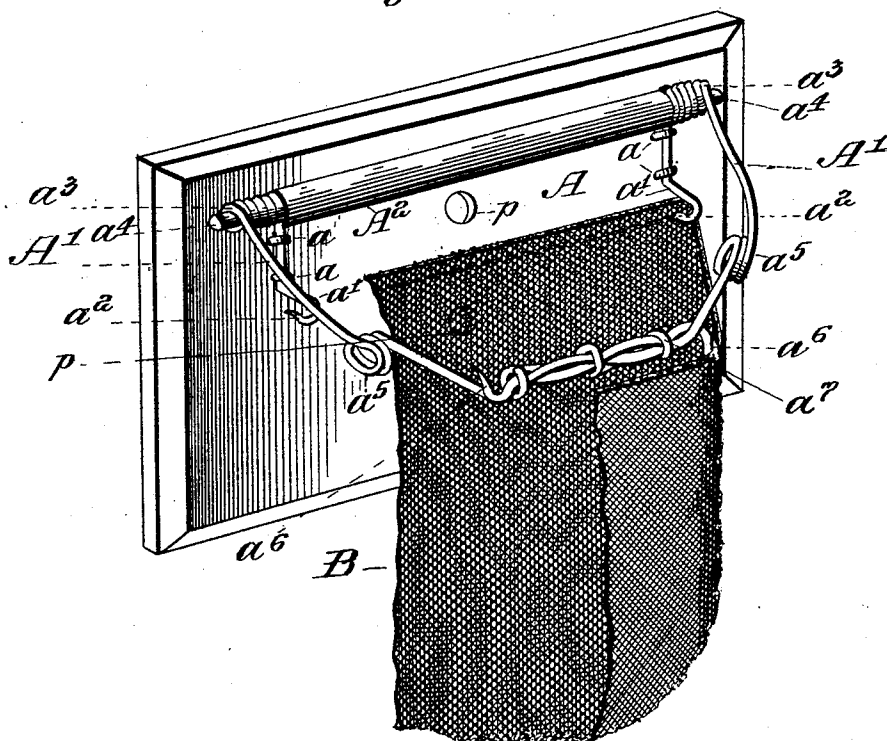
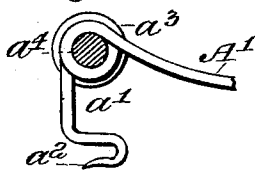

Fig. 2.



Witnesses

Wm. D. S. S. S.
Arthur Ashley

Inventor

Andrew Young
per J. H. S. S.

UNITED STATES PATENT OFFICE.

ANDREW YOUNG, OF EAST RANDOLPH, NEW YORK.

BAG-HOLDER.

SPECIFICATION forming part of Letters Patent No. 435,474, dated September 2, 1890.

Application filed August 3, 1887. Serial No. 246,051. (No model.)

To all whom it may concern:

Be it known that I, ANDREW YOUNG, a citizen of the United States, residing in East Randolph, in the county of Cattaraugus, in the State of New York, have invented a new and useful Bag-Holder, of which the following, in connection with the accompanying drawings, which constitute a part of this specification, is a correct description.

The object of the invention is to provide a bag-holder which shall be simple and inexpensive in its construction, light, and easily portable, readily applicable in position for use, of sufficient stiffness and rigidity to maintain the top of the bag in position against ordinary downward pressure, and of sufficient flexibility to permit the bag to be depressed under such weight or force as would tear it wholly or partially from its place upon the hooks if the holder were not depressible.

With this general purpose in view the invention consists, essentially, in a vertically-adjustable spring supporting-plate and two bag-supporting arms or holders, consisting of strong wires which are securely attached to the spring supporting-plate at a suitable distance apart, the attached ends of the wires being adapted to serve as hooks for the attachment of the rear portion of the bag, and the loose or longer ends being formed into spring-arms, the tips of the wires serving to support the outer portion of the bag, as the attached ends support its inner portion.

In the drawings, Figure 1 represents a front perspective elevation of one form of my invention. Fig. 2 is a detail of one of the supporting-arms, showing, in side elevation, the spring-arm and the short arm and its hook.

As shown in this illustration of the invention, the wire of which each of the two spring-arms A' A' is formed is attached to the supporting-plate A by staples a , which embrace the vertically-placed portions of the wire in such manner that a short arm a' projects outwardly from the plate A, and at a little distance therefrom is bent downward and backward to form a hook a^2 for engagement with the upper rear portion of the bag. This downward and backward extension of the hook permits ready detachment of the bag without lifting the same. At a point near the upper staple the wire is formed into a spring-coil

a^3 , which in this instance encircles the cylindrical end a^4 of a supporting or resistance bar A^2 , from which the arm projects outwardly and slightly downward to a suitable distance, where it is formed into a second spring-coil a^5 , after which the wire is extended still farther downward, and then along the opposite spring-arm until it has reached a position nearly opposite the starting-point of the other spring-arm, where its end is bent outwardly and upwardly to form a hook a^6 for engagement with the upper front portion of the bag. The two wires may be secured together in their front terminal portion by being wound about each other, or by means of a wrapping of wire a^7 , sheet metal, or other suitable material. The perforations p , arranged at different heights one above the other in the plate A, provide for its adjustment at different elevations upon the face of a bin or other vertically-arranged surface, wherever required. If the wire have the requisite stiffness in itself the resistance-bar may in some cases be unnecessary.

Any other suitable means may be substituted for the securing-staples.

The supporting-plate may be either of wood or metal, and the wire may be of steel, iron, or other suitable metal.

Under any ordinary adjustment of the supporting-plate the flexibility of the rear coils a^3 will be sufficient to permit even the shortest grain-bags to descend to and rest upon the floor without danger of tearing the bag. Moreover, these rear springs relieve the strain upon the arms and prevent the bending thereof which would result if the arms were directly and rigidly connected to the supporting-plate. The front spring-coils a^5 serve not only to relieve the strain of downward pressure, but to push out, as it were, the upper front portion of the bag and hold the mouth of the bag fully open, however large the same may be.

Having described my invention, I claim—
1. A bag-holder which embraces a detachable supporting-plate, rear holding-arms which project outwardly from such supporting-plate and which each terminate outwardly in a downwardly and rearwardly extending hook, and front flexible holding-arms which extend outwardly from the supporting-

plate, and which terminate outwardly in an upwardly-extending holding hook or point.

2. In a bag-holder, a supporting-plate which is adapted to be adjusted at different elevations which is provided with flexible projecting bag-supports which extend outwardly, downwardly, and inwardly, and terminate in an engaging point and which is provided also with flexible projecting bag-supports which at a suitable distance apart extend outwardly from such plate and are oppositely placed so as to extend along and engage each other, the outer end of each being pointed and extended upward to perforate and positively engage the bag, substantially as described.

3. A bag-holder which has flexible supporting-arms which have pointed perforating ends, and which has also flexible supporting-arms which have pointed perforating ends, and coils for increasing the resiliency or spring action of such arms.

4. In a bag-holder, a supporting-plate, a resistance-bar which extends along such supporting-plate in a line near the upper extremity thereof, flexible perforating and engaging arms which are secured to the supporting-plate which are coiled around the ends of the resistance-bar, which in their lower portion project outwardly from the plate and are then bent downwardly and inwardly, and which in their upper portion project outwardly over the top of the resistance-bar, and at a suitable distance therefrom are bent into spring-coils, and which, beyond the spring-coils, extend oppositely along each other and are connected together, and each terminates in an upwardly-extending pointed projection, in combination.

ANDREW YOUNG.

Witnesses:

FRANK W. ADAMS,
B. R. JOHNSON.