

W. WRIGHT.
Side-Spring Wagon.

No. 225,779.

Patented Mar. 23, 1880.

Fig. 1.

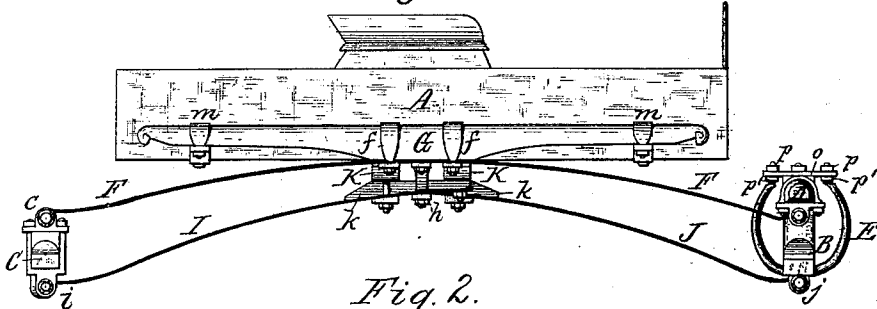

Fig. 2.

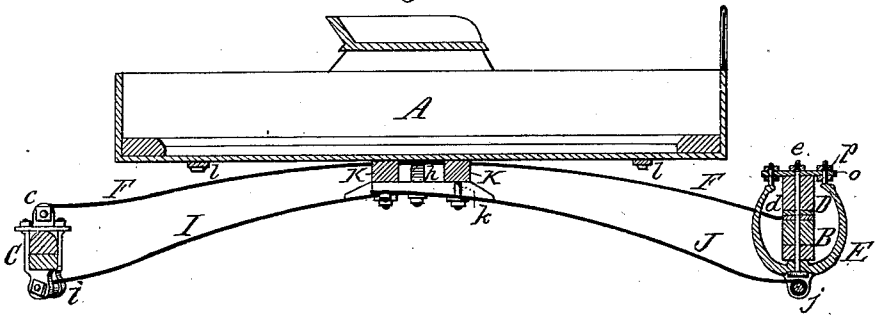

Fig. 3.

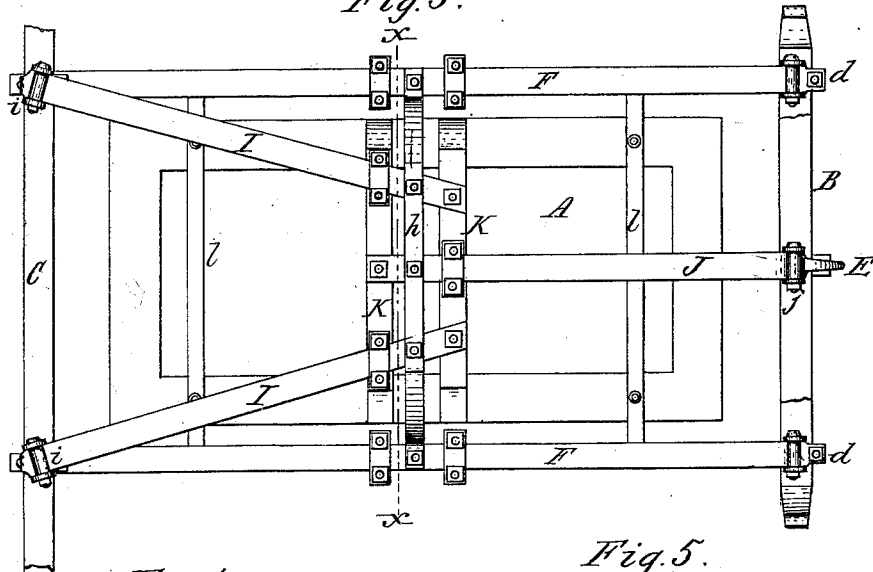

Fig. 4.

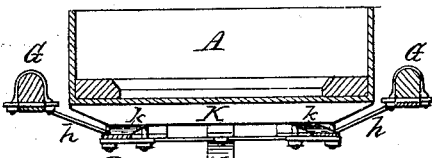
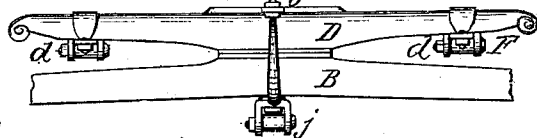

Fig. 5.



Chas. J. Buchheit
Edw. J. Brady. Witnesses.

William Wright Inventor.
By Wilhelm Bornert. Attorneys.

UNITED STATES PATENT OFFICE.

WILLIAM WRIGHT, OF AKRON, NEW YORK.

SIDE-SPRING WAGON.

SPECIFICATION forming part of Letters Patent No. 225,779, dated March 23, 1880.

Application filed May 7, 1879.

To all whom it may concern:

Be it known that I, WILLIAM WRIGHT, of Akron, in the county of Erie and State of New York, have invented a new and useful Improvement in Side-Spring Wagons, of which the following is a specification, reference being had to the accompanying drawings.

This invention relates to that class of vehicles in which the body or box is supported upon springs arranged lengthwise on both sides of the vehicle.

Previous to my invention diagonal springs crossing each other under the vehicle-body have been employed in addition to the side springs. These diagonal springs are objectionable, as they render the vehicle-body too stiff, and distribute the resistance equally under the whole vehicle-body, so that the rear portion thereof, which receives the greater portion of the load, has only as much support as the front portion, which carries only a small portion of the load, whereby the front portion is rendered too stiff, or, if the springs are made light, the rear portion is not sufficiently supported.

The object of my invention is to remedy this difficulty; and it consists in the peculiar construction and arrangement of the springs whereby the vehicle-body is properly supported, as will be hereinafter more fully set forth.

In the accompanying drawings, Figure 1 is a side elevation of the upper portion of a vehicle provided with my improvement. Fig. 2 is a longitudinal section thereof. Fig. 3 is a bottom-plan view thereof. Fig. 4 is a cross-section on line *x x*, Fig. 3. Fig. 5 is a front view of the front axle and bolster.

Like letters of reference designate like parts in the several figures.

A represents the box or body of the vehicle; B, the front axle; C, the rear axle; D, the bolster; E, the yoke connecting the front axle and the bolster, and *e* the king-bolt. F F are the side springs, attached with their ends, respectively, to the bolster D at *d*, and the rear axle, C, at *c*, in the ordinary manner. G G are the side bars, secured centrally to the side springs, F F, by clips *f* in the usual manner. *h* is a cross piece or bar arranged below the vehicle-body, and secured with its ends centrally to the side springs, F F, as shown.

I I are two rearwardly-diverging springs, resting with their front ends upon the cross-piece *h*, and having their rear ends connected with the rear axle, C, at *i*, underneath the side springs, F, as clearly shown. J is a forwardly-extending spring, resting with its rear end upon the cross-piece *h*, between the front ends of the springs I I, and having its front end attached to the yoke E by means of a bifurcated bearing, *j*, formed at the lower end of the yoke E. K K are two transverse pieces, secured above the inner ends of the springs I I J by means of interposed blocks *k* and clips or other suitable fastening devices, for supporting the vehicle-body at the center. *l l* are cross-bars, arranged under the vehicle-body near its ends, and attached to the side bars, G G, by clips *m*, for supporting the ends of the vehicle-body.

The cross-bar *h* ties the two side springs firmly together and transmits any undue load applied to one side of the vehicle-body to the intermediate springs, I I J, and the other side spring, thereby preventing the body from being depressed more on one side than on the other.

The two diverging springs I I form a firm support for the rear portion of the vehicle-body, which receives the greater portion of the load, while the central spring, J, sufficiently supports the front portion of the vehicle-body. In this manner the supporting parts are distributed according to the distribution of the load, and the vehicle-body is consequently properly supported, and at the same time rendered very elastic and yielding.

The springs I, I, and J form a firm connection between the rear axle and the bolster, thereby rendering the ordinary reach and braces in this class of vehicles unnecessary.

The yoke E consists of a U-shaped frame, which straddles the front axle, B, and the bolster D at the center. The upper ends of its legs are provided with screw-threads, and pass through holes in the projecting arms of a plate, *o*, which is secured to the upper side of the bolster. Screw-nuts *p p'* are applied to the legs of the yoke E, respectively, above and below the arms of the plate *o*, so that by adjusting the screw-nuts the bolster and the front axle can be drawn together to compensate for any wear of their bearing-surfaces. The king-

bolt *e* passes through an opening in the lower portion of the yoke *E*, and is secured by a screw-nut on the upper side of the plate *o*.

I claim as my invention—

5 The combination, with the side springs, *F* *F*, and the connecting cross-piece *h*, of the rearwardly-diverging springs *I*, resting with their front ends upon the cross-piece *h*, and having their rear ends connected with the rear axle,

and the forwardly-extending spring *J*, having 10 its rear end resting upon the cross-piece *h*, between the forward ends of the springs *I*, and its front end attached to the yoke *E*, substantially as set forth.

WILLIAM WRIGHT.

Witnesses:

SHEPARD STODDARD,
RICHARD MOTT.