



US00D652178S

(12) **United States Design Patent**
Ford

(10) **Patent No.:** **US D652,178 S**

(45) **Date of Patent:** **** Jan. 10, 2012**

(54) **HORSE-BOOT UPPER**

Primary Examiner — Nanda Bondade

(75) Inventor: **Garrett N. Ford**, Tucson, AZ (US)

(74) *Attorney, Agent, or Firm* — Antonio R. Durando

(73) Assignee: **Easycare, Inc.**, Tucson, AZ (US)

(**) Term: **14 Years**

(57) **CLAIM**

The ornamental design of a horse-boot upper, as shown and described.

(21) Appl. No.: **29/385,377**

(22) Filed: **Feb. 12, 2011**

(51) **LOC (9) Cl.** **30-01**

(52) **U.S. Cl.** **D30/146**

(58) **Field of Classification Search** D30/145-150;
119/814, 850, 856; 54/65, 82; 36/110-115,
36/117.1-117.5, 140; 168/1-4, 14-18, 22;
602/6, 8, 23, 27-29, 65-66

See application file for complete search history.

DESCRIPTION

FIG. 1 is a perspective view of a horse-boot upper showing my design, showing the retaining flap in closed position; FIG. 2 is a front elevational view thereof; FIG. 3 is a left-side elevational view thereof; FIG. 4 is a right-side elevational view thereof; FIG. 5 is a rear elevational view thereof; FIG. 6 is a top plan view thereof; and, FIG. 7 is another rear elevational view thereof showing the retaining flap in open position.

The dash-dot broken line showing the sole of the horse-boot on the drawing disclosure is for illustrative purposes only and forms no part of the claimed design. The broken lines on the upper part of the horse-boot represent stitches.

(56) **References Cited**

U.S. PATENT DOCUMENTS

3,800,504	A *	4/1974	Gregory	54/82
5,224,549	A *	7/1993	Lightner	54/82
5,715,661	A *	2/1998	Meyers	54/82
7,434,378	B2 *	10/2008	Wilson	54/82
D580,111	S *	11/2008	Lander	D30/146

* cited by examiner

1 Claim, 7 Drawing Sheets

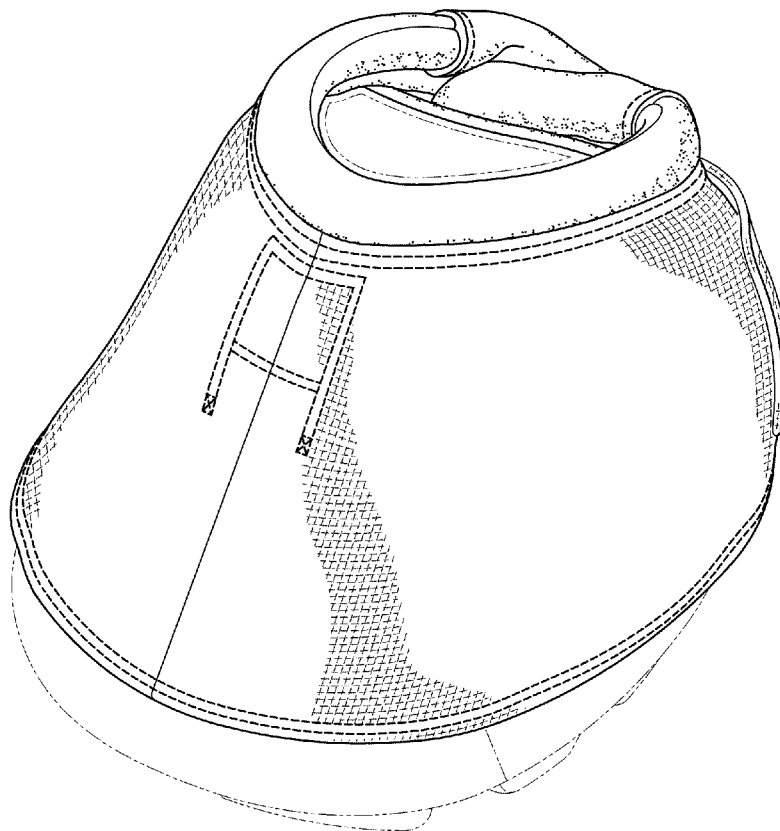

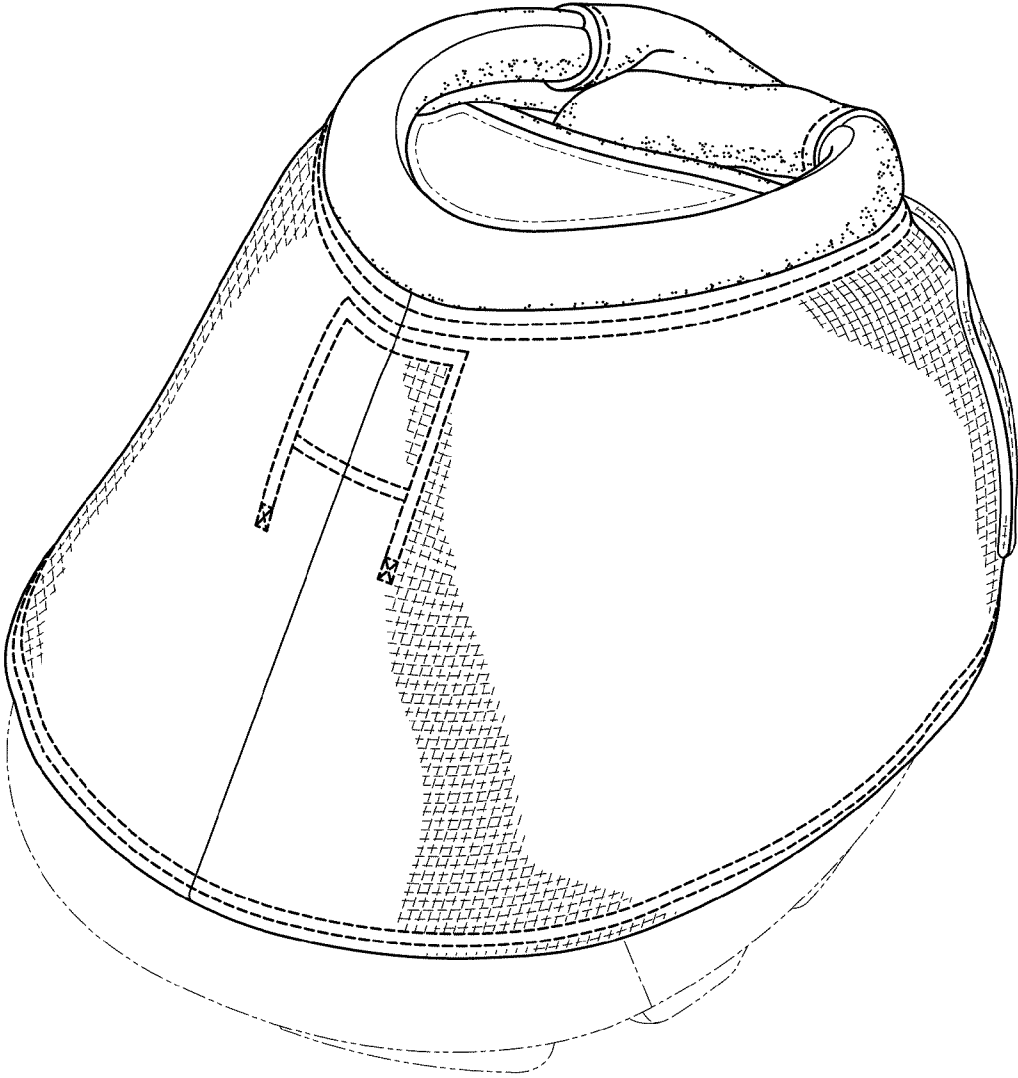

FIG. 1

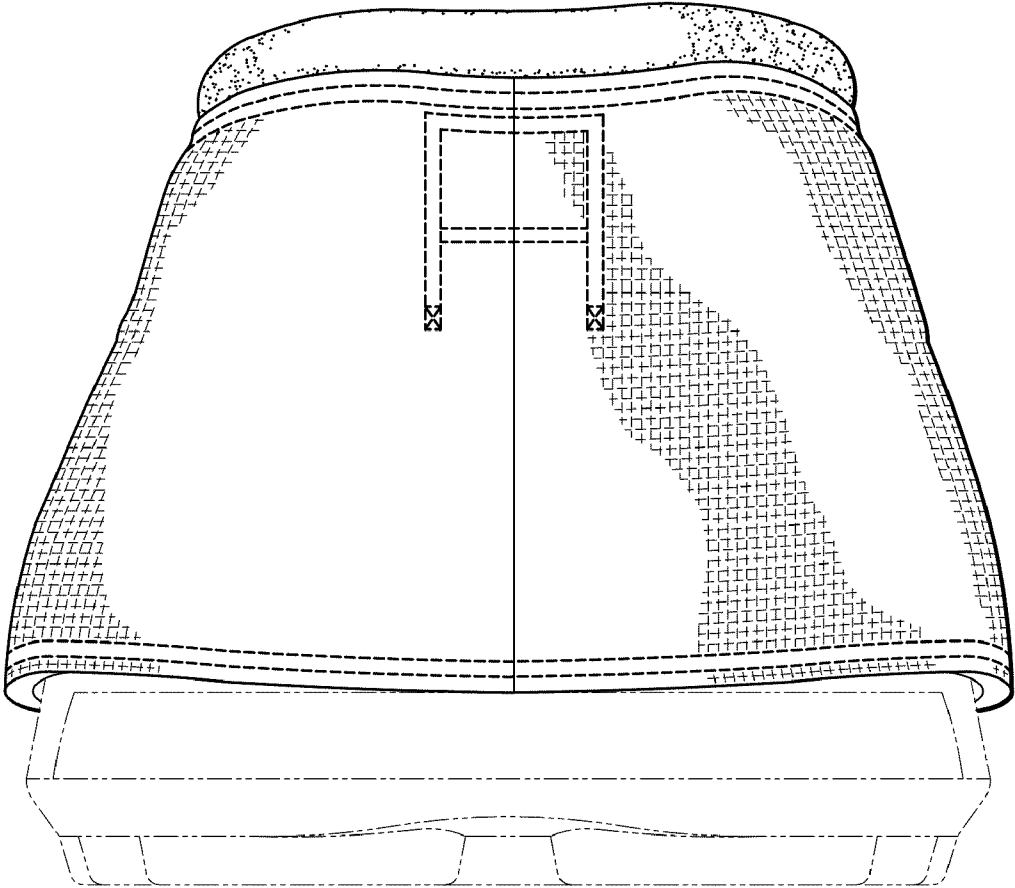

FIG. 2

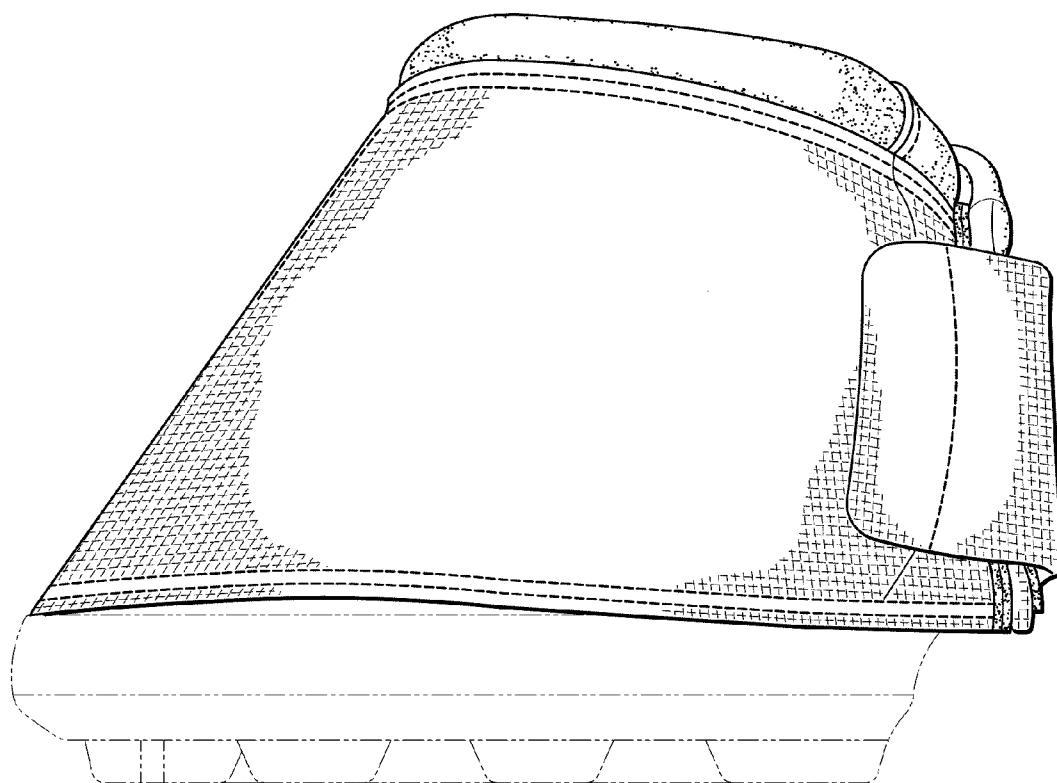

FIG. 3

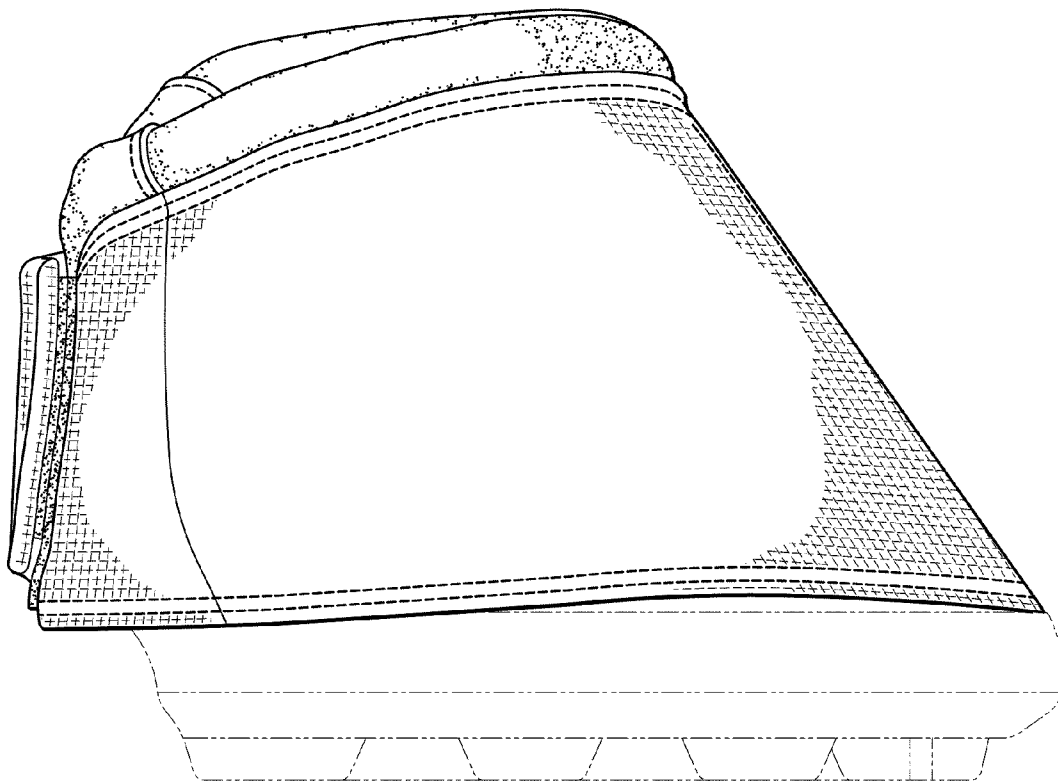

FIG. 4

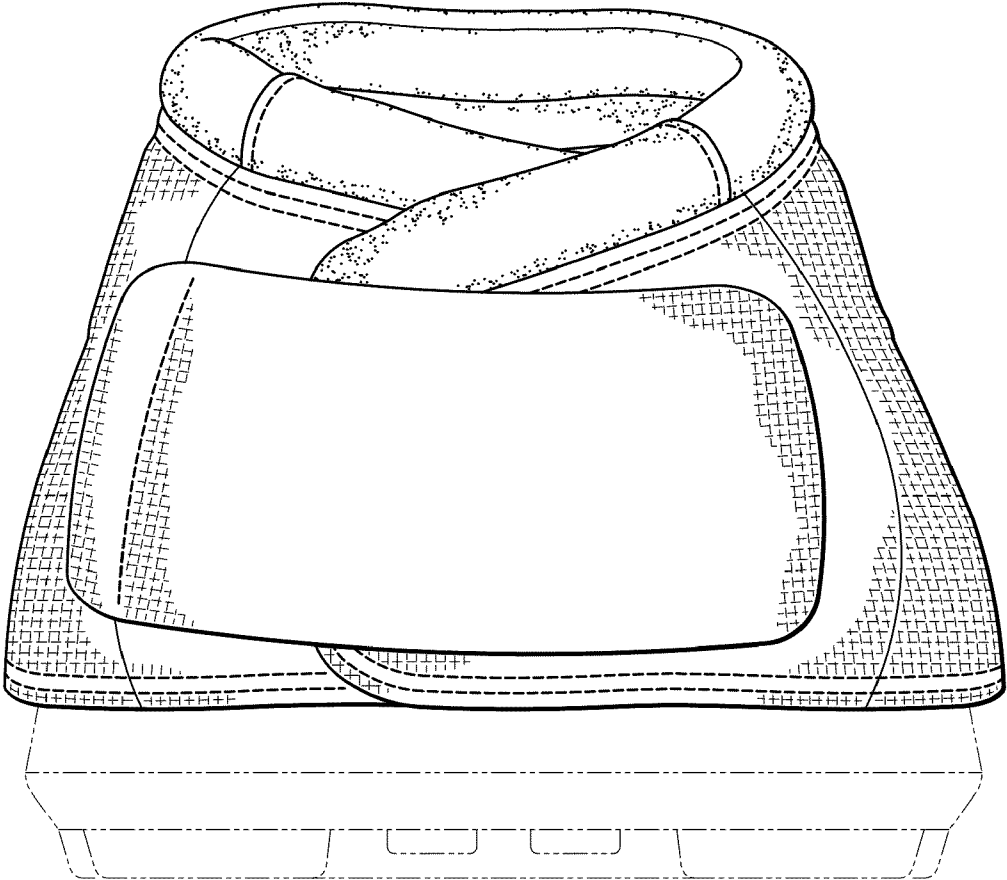

FIG. 5

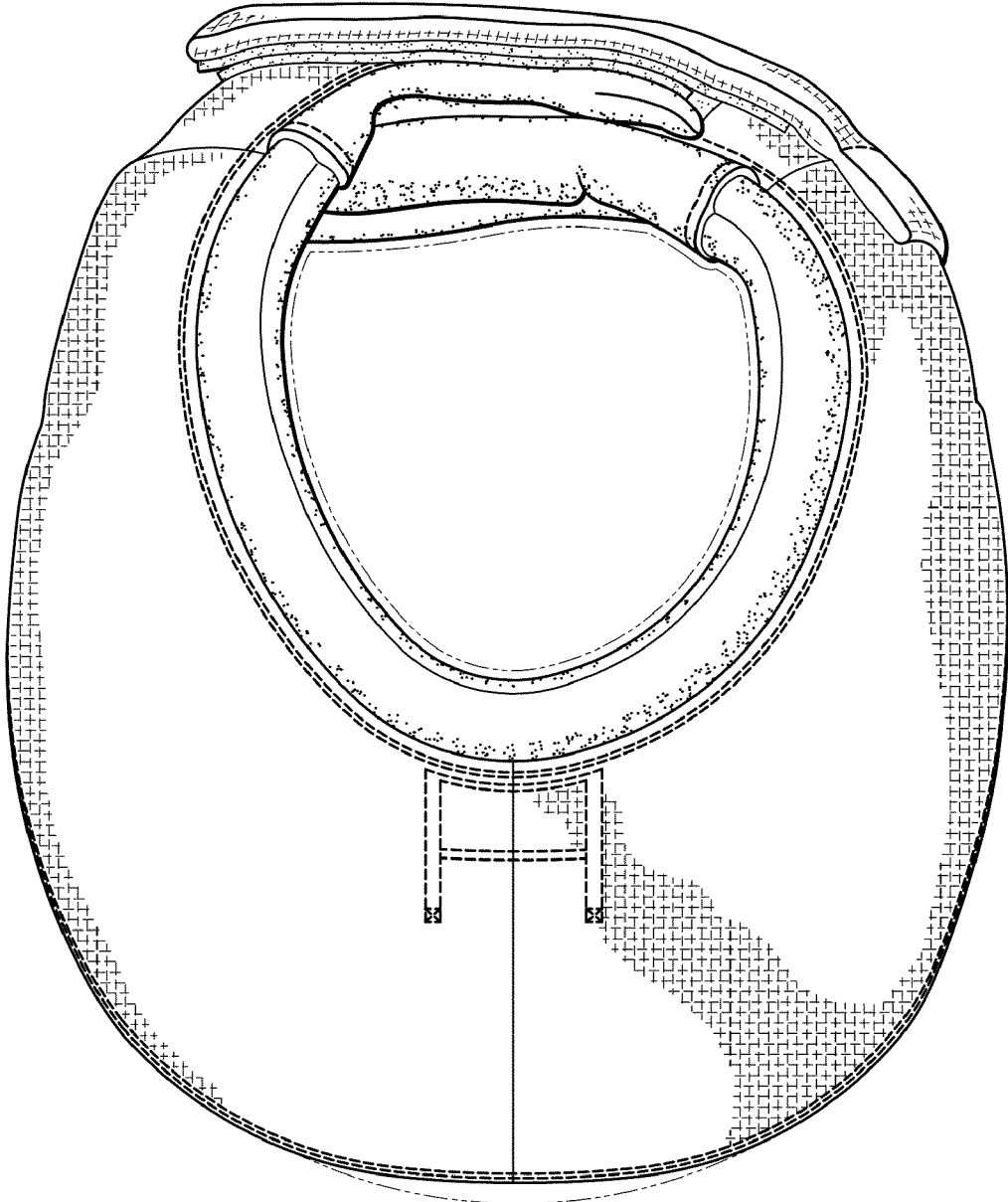

FIG. 6

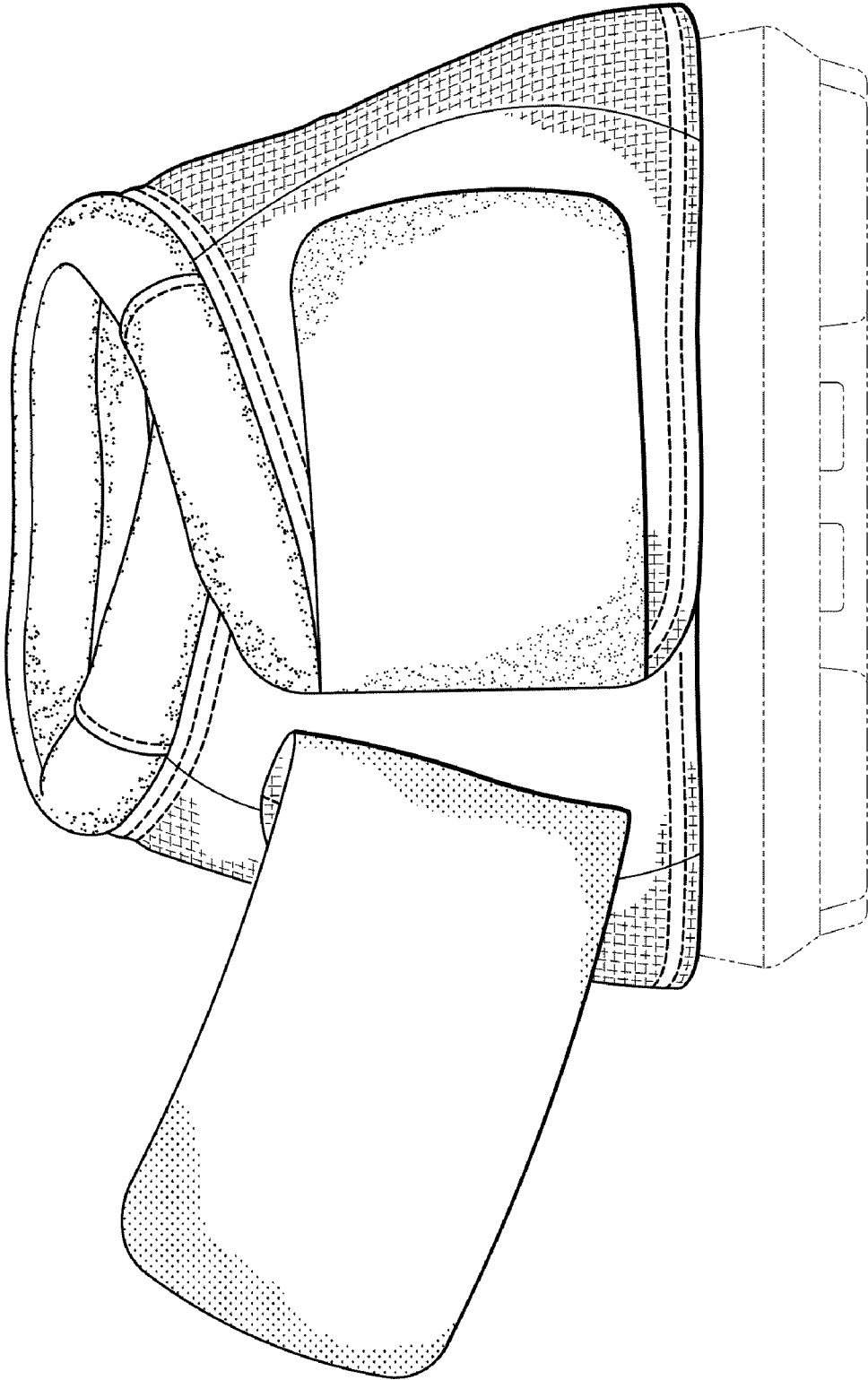

FIG. 7