



INTERNATIONAL APPLICATION PUBLISHED UNDER THE PATENT COOPERATION TREATY (PCT)

(51) International Patent Classification ⁶ : C07K 14/32, A61K 301/385, C12N 15/62, 15/75	A2	(11) International Publication Number: WO 95/19371 (43) International Publication Date: 20 July 1995 (20.07.95)
(21) International Application Number: PCT/EP95/00147 (22) International Filing Date: 13 January 1995 (13.01.95) (30) Priority Data: 9400650.9 14 January 1994 (14.01.94) GB (71) Applicant (for all designated States except US): SOLVAY (SOCIETE ANONYME) [BE/BE]; 33, rue du Prince-Albert, B-1050 Bruxelles (BE). (72) Inventors; and (75) Inventors/Applicants (for US only): DEBLAERE, Rolf, Y. [BE/BE]; Schoolstraat 24, B-9950 Waarschoot (BE). DE- SOMER, Jan [BE/BE]; Nieuwewandeling 58, B-9000 Gand (BE). DHAESE, Patrick [BE/BE]; Jean Fobelaan 8, B-9810 Drongen (BE). (74) Agents: MEYERS, Liliane et al.; Solvay (Société Anonyme), Dept. de la Propriété Industrielle, 310, rue de Ransbeek, B-1120 Bruxelles (BE).		(81) Designated States: JP, US, European patent (AT, BE, CH, DE, DK, ES, FR, GB, GR, IE, IT, LU, MC, NL, PT, SE). Published <i>Without international search report and to be republished upon receipt of that report.</i>
(54) Title: EXPRESSION OF SURFACE LAYER PROTEINS		
(57) Abstract <p>A host cell which is provided with an S-layer comprising a fusion polypeptide consisting essentially of: (a) at least sufficient of an S-layer protein for an S-layer composed thereof to assemble, and (b) a heterologous polypeptide which is fused to either the carboxy terminus of (a) or the amino terminus of (a) and which is thereby presented on the outer surface of the said cell; can be used as a vaccine, for screening for proteins and antigens and as a support for immobilizing an enzyme, peptide or antigen.</p>		

FOR THE PURPOSES OF INFORMATION ONLY

Codes used to identify States party to the PCT on the front pages of pamphlets publishing international applications under the PCT.

AT	Austria	GB	United Kingdom	MR	Mauritania
AU	Australia	GE	Georgia	MW	Malawi
BB	Barbados	GN	Guinea	NE	Niger
BE	Belgium	GR	Greece	NL	Netherlands
BF	Burkina Faso	HU	Hungary	NO	Norway
BG	Bulgaria	IE	Ireland	NZ	New Zealand
BJ	Benin	IT	Italy	PL	Poland
BR	Brazil	JP	Japan	PT	Portugal
BY	Belarus	KE	Kenya	RO	Romania
CA	Canada	KG	Kyrgystan	RU	Russian Federation
CF	Central African Republic	KP	Democratic People's Republic of Korea	SD	Sudan
CG	Congo	KR	Republic of Korea	SE	Sweden
CH	Switzerland	KZ	Kazakhstan	SI	Slovenia
CI	Côte d'Ivoire	LI	Liechtenstein	SK	Slovakia
CM	Cameroon	LK	Sri Lanka	SN	Senegal
CN	China	LU	Luxembourg	TD	Chad
CS	Czechoslovakia	LV	Latvia	TG	Togo
CZ	Czech Republic	MC	Monaco	TJ	Tajikistan
DE	Germany	MD	Republic of Moldova	TT	Trinidad and Tobago
DK	Denmark	MG	Madagascar	UA	Ukraine
ES	Spain	ML	Mali	US	United States of America
FI	Finland	MN	Mongolia	UZ	Uzbekistan
FR	France			VN	Viet Nam
GA	Gabon				

Expression of surface layer proteins

The present invention relates to vaccines and proteins, rDNA molecules encoding protein expression and presentation systems for the production and presentation of the said proteins, expression vectors therefor, and hosts transformed therewith, as well as methods involved therewith.

5 The traditional view on the native polymeric organization of the bacterial cell wall has changed dramatically over recent years with the development of new techniques for electron microscopic analysis. The classical idea that the cell membrane(s) is(are) covered by a peptide-glycan-containing matrix does not hold any longer. Besides additional surface
10 structures such as capsules, sheaths, slimes or fimbriae, proteinaceous surface arrays or S-layers are being recognized as a main constituent of the bacterial cell wall (Sleytr and Messner, 1988).

S-layers are a common feature in archaebacterial surfaces (König, 1988). In some species such as Halobacterium salinarum or Thermoproteus
15 spp. the proteinaceous S-layer even forms the sole cell wall. At present S-layers are being detected with increasing frequency in a large range of gram-positive and gram-negative eubacteria. Surface arrays are composed of protein or glycoprotein subunits that are arranged into a paracrystalline two-dimensional array, displaying hexagonal, tetragonal or oblique
20 symmetry. Self-assembly of the S-layer is an inherent property of the subunit and is the result of non-covalent protein-protein interactions mediated through salt bridging by divalent metal cations (Mg^{2+} or Ca^{2+}). Non-covalent interactions with components of the underlying cell envelope are thought to be responsible for its positioning at the outermost surface.

25 Despite the cloning and the characterization of several genes encoding S-layer proteins (SLP's), their function still remains speculative. A variety of functions have been attributed to surface arrays. They might serve as a protective barrier against degradative enzymes or predators, such as Bdellovibrio or help in maintaining bacterial cell shape and form. In some
30 bacterial pathogens, S-layers have been identified as important virulence factors. Although S-layers have several physical features in common, general conclusions on their function cannot yet be drawn.

- 2 -

SLP's are thus present in a large number of archaeobacteria, as well as gram-positive and, to a lesser extent, gram-negative bacteria. SLP's form a main constituent of the cell wall, being capable of self-assembly into arrays (crystalline arrays) at the outermost surface of the cell wall. SLP's are
5 continuously and spontaneously produced in larger amounts than any other class of protein in the cell.

SLP's are expressed and either presented or secreted by systems therefor within cells. The genes of these SLP system(s) include: strong promoter sequence(s), a signal peptide coding sequence which is located
10 downstream of the promoter sequence(s), a SLP coding sequence and a transcription termination sequence. The SLP coding sequence is located downstream from the signal peptide coding sequence, having its 5'-terminus operatively linked to the 3'-terminus of the signal peptide coding sequence.

As described herein, an SLP presentation system is distinguished from
15 an SLP secretion system. In the former, the SLP's are bound-up in the cell wall of a host where they are thus presented. In the latter, the SLP's are either produced in the cytoplasm (intracellular production) or secreted into the surrounding medium (extracellular secretion).

The SLP expression and secretion systems of several bacteria have been
20 well-characterized. Among these are those SLP expression and secretion systems of bacteria of the genus Bacillus. Bacilli are well-known as abundant producers of SLP's.

More particularly, the SLP expression and secretion system of the
25 species Bacillus brevis has been extensively studied for its potential use in expressing and extracellularly secreting large quantities of predetermined proteins. B. brevis is able to secrete large amounts of extracellular SLP which are used to aid translocation of the predetermined protein across B. brevis's unique two-layer cell wall for extracellular secretion thereof. Also, B. brevis does not secrete extracellular proteases in quantities which may
30 degrade and inactivate the extracellularly-produced proteins.

Tsukagoshi et al (1985) discloses the fusion of the α -amylase gene of Bacillus stearothermophilus DY-5 to the SLP coding gene of B. brevis 47-5
35 for the expression of α -amylase in B. stearothermophilus DY-5, B. brevis 47-5, Escherichia coli HB101 and Bacillus subtilis 1A289 hosts that are transformed therewith. Comparison studies showed that the B. brevis secretion levels were one hundred (100) times higher than that of B.

stearothermophilus itself. B. brevis secretion levels were fifteen (15) times higher than those of E. coli and five (5) times higher than those of B. subtilis. The efficient secretion of the enzyme in B. brevis is suggested therein as being due to the unique properties of the cell wall of the B. brevis.

5 Yamagata et al (1987) discloses the translational fusion of the 5'-region of the gene coding for the middle wall protein (a SLP particular to B. brevis) of B. brevis 47 with the α -amylase gene of Bacillus licheniformis for expression in B. brevis 47. The translational fusion of these genes is reported as achieving efficient levels of α -amylase production in B. brevis 10 47.

Tsukagoshi (1987/8) discloses the translational fusion of the gene coding for swine pepsinogen with the 5'-region of the middle wall protein gene of B. brevis for expression in B. brevis 47 and B. brevis HPD31. 15 Translational fusion of the 5'-region to the CGTase gene of Bacillus macerans also resulted in the expression of the efficient levels of CGTase in B. brevis 47.

EP-A-0257189 in the name of Higeta Shoyu Co., Ltd., et al., discloses a series of B. brevis strains which may be utilised as hosts to produce large 20 amounts of proteins without producing deleterious amounts of extracellular proteases.

GB-A-2182664 in the name of Udaka discloses "expressing genes" that are derived from B. brevis 47 and which may be fused to genes coding for heterologous proteins. Among the heterologous genes suggested as being 25 appropriate for being fused to the genes derived from B. brevis 47 are various eucaryotic genes (such as those genes coding for interferon and insulin) as well as procaryotic genes (such as those genes coding for tryptophanase and aspartate ammonia lyase). The fused genes may then be incorporated into expression vectors for transforming B. brevis 47.

30 Adachi et al (1989) discloses the fusion of the co-transcriptional cell wall protein (cwp) gene operon (coding for both the middle wall protein and the outer wall protein) of B. brevis 47 with the gene coding for α -amylase in B. licheniformis in order to provide extracellular production of B. licheniformis α -amylase by B. brevis 47 and B. subtilis 1A289. The presence of several different cwp operon transcripts and the presence of at 35 least three different promoters (referred as therein as the P1, P2 and P3

promoters) were confirmed. It was reported that the P1 and P3 promoters were used in the same extent in B. brevis and B. subtilis, whereas the P2 promoter was reported to be used much less frequently in B. subtilis than in B. brevis.

5 Takao et al (1989) discloses an expression-secretion vector for transforming B. brevis hosts for producing heterologous proteins, including eucaryotic proteins, such as swine pepinogen. The vector utilizes the promoter, the signal-peptide coding sequences and nine (9) amino-terminal amino acids of a middle wall protein of B. brevis which are fused to a
10 heterologous protein coding sequence. The hosts transformed thereby are B. brevis 47 and HPD31.

Yamagata et al (1989) discloses a host-vector system utilizing strains (47 and HPD31) of B. brevis that hyperproduce SLP's as the hosts. Expression-secretion vectors are constructed from multiple promoters, the
15 peptide-signal coding region and a structural gene for one of the major cell wall proteins of B. brevis 47. The B. brevis 47 genes were fused to a synthetic gene coding for human epidermal growth factor (hEGF).

In addition to the use of SLP expression and secretion systems derived from B. brevis in B. brevis, it has also been disclosed to utilize SLP
20 expression and secretion systems of B. brevis in B. subtilis hosts. Tsuboi et al (1989) discloses the transformation of B. subtilis with genes from B. brevis 47 that code for middle wall proteins. The transformed B. subtilis is thus capable of expressing the middle wall protein of B. brevis.

It has also been disclosed by Tang et al (1989) that the SLP expression and secretion system of an alkaline phosphatase secretion-deficient mutant
25 strain (strain NM 105) of B. licheniformis 749/C can be cloned into mutant strains of both E. coli (strain NM 539) and B. subtilis (strain MI112). Bowditch et al 1989 discloses cloning the gene coding for the SLP of B. sphaericus into E. coli TB1, JM101 and JM107. The transformed E. coli
30 hosts then expressed the B. sphaericus SLP.

Lucas et al (1994), while studying the S-layer protein of Acetogenium kivui, disclose that there exists a repeated peptide sequence at the N-terminus of said S-layer protein which is shared by several different S-layer proteins, such as the middle wall protein from B. brevis and the S-layer protein from B. sphaericus 2362, and these authors suggest that this
35 conserved domain is essential to anchor these S-layer proteins to the

- 5 -

underlying peptidoglucan. Interestingly, Matuschek *et al.* (1994) disclose that the same conserved domain, which is found at the N-terminus of the *Acetogenium kivui* S-layer, is also present in the sequence of the extracellular, cell-bound pullulanase from *Thermoanaerobacterium*
5 *thermosulfurigenes*, but in the latter case it is located near the C-terminus of the polypeptide.

US-A-5043158 discloses pharmaceutical compositions which comprise carriers that are chemically-coupled to epitope-bearing moieties. The carriers are isolated crystalline or paracrystalline glycoproteins, especially
10 those derived from the SLP's of *Clostridium thermohydrosulfuricum* and *B. stearothermophilus*. The conjugates formed thereby were reported as being capable of eliciting the formation of antibodies as well as eliciting B-cell mediated and T-cell mediated responses.

It is a primary objective of the present invention to provide a
15 recombinant DNA (rDNA) molecule that includes a SLP system capable of expressing and presenting, rather than expressing and secreting, a fusion polypeptide (such as a fused SLP/antigenic peptide) in a wide variety of bacteria including bacteria of the genus *Bacillus* and, more particularly, *B. sphaericus*.

20 It is yet another primary object of the present invention to provide such a rDNA molecule which includes, derived from *B. sphaericus*, SLP promoter sequence(s), a SLP signal-peptide coding sequence and a SLP coding sequence which codes for at least a functional portion of the surface layer protein of *B. sphaericus* and which may be fused to a heterologous
25 coding sequence coding for a heterologous polypeptide (such as an antigenic peptide), such that the expression of the heterologous polypeptide is placed under the control of the said promoter(s) and further such that the heterologous polypeptide expressed thereby will be fused to the SLP so as to be bound-up in the cell wall of the host for presentation thereof on the
30 outer surface of the host's cell wall for eliciting an immunogenic response thereto.

It is a yet further primary object of the present invention to provide vectors containing such rDNA molecules, which vectors may be used to effectively transform host cells.

35 It is a still yet further primary object of the present invention to provide hosts, especially hosts of the genus *Bacillus*, and more particularly of the

species B. sphaericus, which are transformed with vectors containing such rDNA molecules, which express fusion polypeptides (such as antigenic peptides) produced thereby and which present the expressed fusion polypeptides for, inter alia, eliciting an immunogenic response thereto.

5 A still further primary object of the present invention is to provide methods for forming the rDNA molecules, for preparing the appropriate vectors therefor, for transforming hosts with such vectors and for producing the fusion peptides (vaccines and proteins) of the present invention.

10 The present invention provides a host cell which is provided with a S-layer comprising a fusion polypeptide consisting essentially of:

(a) at least sufficient of a SLP for a S-layer composed thereof to assemble, and

(b) a heterologous polypeptide which is fused to either the carboxy terminus of (a) or the amino terminus of (a) and which is thereby presented on the outer surface of the said cell.

15 Preferably, the heterologous polypeptide is fused to the carboxy terminus of (a).

20 The amount of a SLP which is sufficient in its own right for a S-layer composed thereof to form is termed herein the "functional portion" of the SLP. The fusion polypeptide thus typically incorporates at least the functional portion of a SLP native to the host cell. Sacculi derived from a host cell according to the invention also form part of the invention.

25 The heterologous polypeptide may be an antigenic peptide. In that event, the invention provides a vaccine comprising a host cell or sacculi according to the invention wherein the heterologous polypeptide is an antigenic peptide and a pharmaceutically or veterinarily acceptable carrier or diluent.

30 The invention further provides a recombinant DNA molecule which comprises a promoter operably linked to a coding sequence which encodes a signal peptide and a fusion polypeptide, the signal peptide being capable of directing the said fusion polypeptide to be presented on the surface of a host cell in which expression occurs and the fusion polypeptide consisting essentially of a heterologous polypeptide fused to either the carboxy terminus or to the amino terminus of at least sufficient of a SLP for a S-layer composed thereof to assemble.

35 An efficient and reliable system which employs an SLP expression and

- 7 -

presentation system is therefore provided for the expression and presentation of fusion polypeptides (such as antigenic peptides for vaccines) in a wide variety of, preferably, Bacilli. This system includes a recombinant DNA molecule having a promoter that is fused to a functional DNA sequence, so
5 that the functional DNA sequence is placed under the control of the promoter. The functional DNA sequence includes a SLP coding sequence which codes for at least a functional portion of a SLP. The functional DNA sequence further includes a heterologous polypeptide coding sequence that codes for a heterologous polypeptide (such as an antigenic peptide for use as
10 a vaccine or a protein) which peptide coding sequence is fused to the SLP coding sequence.

As used herein, the term "functional DNA sequence" refers to DNA sequences that contain all of the various sequences (with the exception of the promoter sequence), both coding (such as sequences coding for the
15 proteins whose expression and presentation is desired) and non-coding (such as control sequences and regulatory regions, i.e. sequences that are necessary or desirable for the transcription and translation of a coding sequence to which they are operably linked or fused when they are compatible with the host into which they are placed) which, when operably
20 joined (by linking, fusing or otherwise) to a promoter and placed into a compatible host, permit the sequence to be operational and express and present the protein(s) coded for by the coding sequence(s) thereof.

As used herein, the terms "presented", "presentation", "present" and/or "presents" refer to the manner in which the heterologous polypeptide (for
25 example an antigenic peptide or protein) is positioned when provided as part of a hybrid particle (such as the fusion vaccine or fusion protein) in such a way as to elicit an immune response to the heterologous polypeptide.

"Presentation systems" are DNA sequences which include both a coding sequence coding for a polypeptide (such as a heterologous polypeptide)
30 whose presentation is desired, and other appropriate sequences therefore which permit such presentation when the DNA sequences are compatible with the host into which they are placed.

"Expressions systems" are DNA sequences which include both a coding sequence coding for polypeptide(s) whose expression is desired and
35 appropriate control sequences therefor which permits such expression when the DNA sequences are compatible with the host into which they are placed.

As is generally understood, "control sequences" refers to DNA segments which are required for, or which regulate, expression of the coding sequence with which they are operably joined.

We have found that it is the amino-terminal portion of a SLP which is sufficient for S-layer formation. We have found that more than the first 5 19.56% by number of the amino acid residues, as measured from the amino-terminus of a mature SLP, are required for a S-layer to form. By a "mature SLP" we mean a SLP without signal peptide residues. More than the N-terminal 239 amino acid residues of the mature SLP shown in Figure 10 6 are thus required. The first 41.41% by number of the amino acid residues of a mature SLP are sufficient, for example the first 506 amino acid residues of the mature SLP shown in Figure 6.

More than the first 20% amino acid residues of an active SLP may be present. The SLP portion of a fusion polypeptide may therefore consist of 15 the first N-terminal 28% or more or 35% or more, for example the most N-terminal 41% or more or 50% or more or 60% or more or 80% or more, or even all, amino acid residues of a mature SLP such as the mature SLP shown in Figure 6. From the first N-terminal 28% to all, for example from 20 the first N-terminal 35% or 41% or 50% or 60% or 80% to all, of the amino acid residues of a mature SLP can be present. The first N-terminal 400 or more, 600 or more, 800 or more or 1000 or more amino acid residues of a mature SLP may be present. A convenient restriction site in the DNA coding sequence of a SLP will typically determine the C-terminus of the SLP portion of a fusion polypeptide.

25 The SLP portion of a fusion polypeptide is typically homologous with respect to the host cell in which the fusion polypeptide is expressed. In other words, the portion of the SLP which is present in the fusion polypeptide should generally be from a SLP of the same species as the host in which the fusion polypeptide is expressed. Typically the portion of the 30 SLP in the fusion polypeptide is from the native SLP of the host in which the fusion polypeptide is expressed. The fusion polypeptide may incorporate an appropriate portion of a SLP of a bacterium of the genus Bacillus, for example of the species B. brevis or B. sphaericus.

35 The heterologous polypeptide may be a physiologically active polypeptide or a foreign epitope (an antigenic determinant, peptide immunogen or epitope-bearing moiety, as shall be discussed at greater

length below). The carboxy terminus of the functional portion of a SLP may be fused directly to the amino terminus of the physiologically active polypeptide or the foreign epitope. The fusion polypeptide therefore may consist essentially of the functional portion of a SLP and, fused directly to the carboxy terminus thereof, a heterologous amino acid sequence.

Alternatively, the amino terminus of the functional portion of a SLP may be fused directly to the carboxy terminus of the physiologically active polypeptide or the foreign epitope. The fusion polypeptide therefore may consist essentially of the functional portion of a SLP and, fused directly to the amino terminus thereof, a heterologous amino acid sequence.

Alternatively, an intervening linker sequence may be present between the functional portion of the SLP and the heterologous polypeptide. The linker sequence may be from 1 to 20, for example, from 1 to 5 or from 1 to 10 amino acid residues long. The linker sequence may be designed to incorporate a cleavage site recognized by cyanogen bromide or a cleavage enzyme.

The heterologous polypeptide is a polypeptide whose expression is not normally controlled by a SLP promoter i.e. is not a naturally occurring SLP. The heterologous polypeptide can be a physiologically active polypeptide such as an enzyme. The polypeptide may be a polypeptide drug or a cytokine. Specific polypeptides which may be mentioned are α -amylase, tissue plasminogen activator, luteinizing hormone releasing hormone, a growth hormone such as human growth hormone, insulin, erythropoietin, an interferon such as α -interferon, and calcitonin.

Alternatively, the heterologous polypeptide may comprise a foreign epitope or polypeptide immunogen. The polypeptide immunogen therefore typically comprises an antigenic determinant of a pathogenic organism. The immunogen can be an antigen of a pathogen. The pathogen may be a virus, bacterium, fungus, yeast or parasite. The foreign epitope may be an epitope capable of inducing neutralizing or non-neutralizing antibody or of inducing a cellular immune response.

The immunogen or epitope may be derived from a virus such as a human immunodeficiency virus (HIV) such as HIV-1 or HIV-2; a hepatitis virus such as hepatitis A, B or C; a poliovirus such as poliovirus type 1, 2 or 3; influenza virus; rabies virus; or measles virus. Examples of bacteria from which an immunogen or epitope may be derived include B. pertussis,

- 10 -

C. tetani, V. cholera, N. meningitides, N. gonorrhoea, C. trachomatis and E. coli. The immunogen may therefore be the P69 antigen of B. pertussis, pertussis toxin or a subunit thereof, tetanus toxin fragment C, E. coli heat labile toxin B subunit (LT-B) or an E. coli K88 antigen, or an antigenic
5 portion thereof. An immunogen derived from a parasite may be an immunogen derived from P. falciparum, a causative agent of malaria.

As used herein, the terms "antigenic peptide", "antigenic determinant", "peptide immunogen", "polypeptide immunogen", "epitope" and "epitope-bearing moiety" all refer to substances that contain a specific determinant
10 which induces an immune response (such as the production of antibodies or the elicitation of T-cell mediated response). The substance may itself be a hapten (i.e. a simple moiety which, when rendered immunogenic, behaves as an antigen) or it may be a more complex moiety, only portions of which are responsible for immunospecificity with regard to the antibodies
15 obtained.

As used herein, the terms "immunogenic response" and "immune response" refer to the biological responses, such as the raising of antibodies or the elicitation of T-cell or B-cell mediated responses, that are elicited in an organism (such as a mammal) by the presence of an antigen or
20 immunogen.

The present invention also provides recombinant DNA vectors comprising a recombinant DNA molecule according to the present invention and further provides a host cell transformed with such a recombinant DNA vector. The vector is typically an expression vector. The fusion
25 polypeptide can thereby be expressed in a suitable host cell transformed with such an expression vector. A S-layer composed of the fusion polypeptide that is expressed can thereby be assembled on the surface of the host cell.

An expression vector can include any suitable origin of replication
30 which will enable the vector to replicate in a bacterium. A ribosome binding site is provided. The ribosome binding site is suitably located between the promoter and the DNA sequence encoding the heterologous polypeptide. If desired, a selectable marker gene such as an antibiotic resistance gene can be provided in the vector. The vector is generally a
35 plasmid.

The vector is normally provided with a transcriptional termination

sequence. The coding sequences of the recombinant DNA molecules and vectors of the invention are provided with translational start and stop codons. Vectors may be constructed by assembling all appropriate elements using techniques known in the art (Sambrook *et al.*, 1989).

5 According to the invention, a host cell provided with a S-layer comprising a fusion polypeptide is prepared by a process which comprises :

- (i) providing a suitable host cell incorporating a recombinant DNA molecule which comprises a promoter operably linked to a coding sequence which encodes a signal peptide and a fusion polypeptide, the signal peptide being capable of directing the said fusion polypeptide to be presented on the surface of the said host cell and the fusion polypeptide consisting essentially of a heterologous polypeptide fused to either the carboxy terminus or the amino terminus of at least sufficient portion of a S-layer protein for a S-layer composed thereof to assemble on the surface of the said host cell; and
- 10
- 15
- (ii) culturing the said host cell so that the said fusion polypeptide is expressed and a S-layer comprising the fusion polypeptide is formed on the surface of the said host cell, the heterologous polypeptide thereby being presented on the outer surface of the said host cell.

20 In a preferred variant of the invention, a host cell provided with a S-layer comprising a fusion polypeptide is prepared by a process which comprises :

- (i) providing a suitable host cell incorporating a recombinant DNA molecule which comprises a promoter operably linked to a coding sequence which encodes a signal peptide and a fusion polypeptide, the signal peptide being capable of directing the said fusion polypeptide to be presented on the surface of the said host cell and the fusion polypeptide consisting essentially of a heterologous polypeptide fused to the carboxy terminus of at least sufficient of the amino terminal portion of a S-layer protein for a S-layer composed thereof to assemble on the surface of the said host cell; and
- 25
- 30
- (ii) culturing the said host cell so that the said fusion polypeptide is expressed and a S-layer comprising the fusion polypeptide is formed on the surface of the said host cell, the heterologous polypeptide thereby being presented on the outer surface of the said host cell.

35

Preferably the host cell is one which does not secrete extracellular

proteases. The host cell is generally a bacterium, typically a bacterium which naturally produces a S-layer protein, i.e. a bacterium which in its native state has a S-layer on its surface. Depending upon the intended use, the bacterium may be a gram-positive or gram-negative bacterium. Host
5 bacteria include bacteria of the genera Cocci and Bacilli may be transformed, for example Staphylococcus, Streptococcus, Corynebacterium, Lactobacillus, Bacillus, Clostridium and Listeria. Preferably, host bacteria include bacteria of the genera Bacilli. Useful bacteria in which the present invention may be applied are therefore Bacillus sphaericus and B. brevis.

10 Bacillus sphaericus is a bacterium of the genus Bacillus in which a substantial quantity of the SLP's produced thereby are bound-up in the S-layer of the cell wall thereof and are not secreted extracellularly. As such, unlike B. brevis and B. subtilis, we have found that B. sphaericus possesses what is potentially an efficient SLP presentation system.

15 The structure and properties of B. sphaericus have been characterized (see, for example Lewis et al (1987); Howard et al (1973) and Lepault et al (1986)).

B. sphaericus (like the other Bacilli) has a high level of growth throughout its growth cycle, thereby increasing the quantities of the fusion polypeptide that can be expressed and presented thereby.
20

A preferred strain of B.sphaericus is B.sphaericus P-1. B.sphaericus P-1 has been deposited under the Budapest Treaty of the Belgian Coordinated Collections of Microorganisms (BCCM), LMG Culture Collection, Universiteit Gent, Lab. voor Microbiologie, K.L.
25 Ledeganckstraat 35, B-9000 Gent, Belgium. The deposit was made on 13th May 1993 and was given accession number LMG P-13855. B. sphaericus P-1 offers the further advantage of not producing detectable levels of extracellular proteases which can cause damage to fusing polypeptides produced according to the invention.

30 The signal peptide is typically a signal peptide for a SLP, for example for a SLP of a bacterium of the genus Bacillus. It may be a signal peptide for a SLP of B. brevis, B. sphaericus or B. subtilis for example B. sphaericus P-1. Preferably the signal peptide is the signal peptide for the SLP of which an appropriate portion is incorporated in the fusion
35 polypeptide. A signal peptide which is homologous, i.e. which is derived from the same species of cell, with respect to the host cell in which

expression of the fusion polypeptide is to occur can be employed. Preferably the native signal peptide for the native SLP of the host cell in which expression is to occur is provided.

5 A useful process for preparing a host cell provided with a S-layer comprising a fusion polypeptide comprises:

- (a) providing an intermediate vector in which the coding sequence for an internal portion of the native SLP of the said host cell has translationally fused to the 3'-end thereof the coding sequence for the heterologous polypeptide and in which the said coding sequences are provided upstream of a promoterless selectable marker gene such that they form a translational or transcriptional fusion therewith;
- (b) transforming the said host cell with the intermediate vector;
- (c) selecting a transformed host cell which has a S-layer comprising the said fusion polypeptide.

15 This process relies upon the occurrence of a single homologous recombination as a result of the introduction of the intermediate vector into the host cell. The intermediate vector is typically a plasmid. An internal portion of the native SLP lacks the amino-terminal and carboxy-terminal amino acid residues of the native SLP. Up to the first 50, up to the first 100, up to the first 200, up to the first 300, up to the first 400 or up to the first 500 of the amino-terminal amino acid residues may be missing. Independently up to the first 50, up to the first 100, up to the first 200, up to the first 300, up to the first 400 or up to the first 500 carboxy-terminal amino acid residues may be missing.

25 The coding sequence for an internal portion of the native SLP therefore corresponds to the native SLP gene lacking its 5'- and 3'-ends. This coding sequence can be fused directly or via a sequence encoding a linker to the 5'-end of the coding sequence for the heterologous peptide. Suitable linkers are described above. The promoterless selectable marker gene may be the neomycin phosphotransferase II (nptII) gene which confers resistance to the antibiotics neomycin and kanamycin. The intermediate vector typically also comprises an origin of replication and a second selectable marker gene, for example an antibiotic resistance gene such as an erythromycin resistance gene.

35 In one preferred embodiment, therefore, a host cell having a S-layer comprising a fusion polypeptide can be prepared by the following

procedure:

1. An appropriate intermediate vector is constructed that has following characteristics :
 - the cloned part of the SLP in the vector has to be internal to the SLP gene, i.e. contain no borders of the gene;
 - the cloned part of the SLP gene is translationally fused to the sequence encoding the heterologous peptide of interest;
 - both are cloned upstream of a promoterless first selectable marker gene (e.g. the *nptII* gene) so that they make a translational or transcriptional fusion;
 - optionally a replicon (such as that of *pIL253* for *B. sphaericus*) and/or a second selectable marker gene (such as the erythromycin (Em) resistance gene).
 2. The intermediate vector is introduced into an appropriate host cell such as *B. sphaericus* P-1, for example via electroporation.
 3. Transformants are selected by means of the second selectable marker, for example Em resistant transformants selected. This can enable the structure of the intermediate vector to be verified.
 4. The selected transformant(s) are grown, for example overnight in LB medium containing 10 $\mu\text{g/ml}$ Em.
 5. The transformants thus grown are plated out. For example a bacterial suspension can be plated out directly on LB+ agar containing 5-10 $\mu\text{g/ml}$ neomycin (Nm) when the first selectable marker gene is the *nptII* gene or dilute starter culture in LB liquid medium containing the same amount of Nm, again when the first selectable marker gene is the *nptII* gene.
 6. Colonies are selected by means of the first selectable marker, for example single Nm resistant colonies.
 7. Occurrence of a single homologous recombination is verified, for example by Southern analysis.
 8. Formation of the recombinant fusion polypeptide is verified, for example by sodium dodecyl sulphate-polyacrylamide gel electrophoresis (SDS-PAGE).
- Alternatively, a host cell provided with a S-layer comprising a fusion polypeptide can be produced by a process comprising:
- (a) fusing to a promoter a SLP coding sequence coding for the signal

- 15 -

- peptide and at least sufficient of the amino-terminal portion of a SLP for a S-layer composed thereof to assemble on the surface of the host cell, and fusing a peptide coding sequence coding for the heterologous polypeptide to the 3'-end of the SLP coding sequence, whereby a recombinant DNA molecule for the expression and presentation of the fusion polypeptide is prepared;
- 5 (b) inserting the recombinant DNA molecule into a suitable vector, whereby a recombinant DNA vector is prepared;
- (c) transforming a suitable host cell with the recombinant DNA vector, whereby a transformed host cell having the recombinant DNA molecule is provided;
- 10 (d) culturing the transformed host cell, whereby the fusion polypeptide is expressed and a S-layer comprising the fusion polypeptide is assembled on the host cell wall.

15 The transformed host cell is thus cultured in an appropriate culture medium. As a result of expression and presentation of the fusion polypeptide on the outer surface of the host cell, the heterologous polypeptide is thus presented so that an immunogenic response can be stimulated thereto when the host cell is administered to a human or animal host. The S-layer will also comprise the host cell's native SLP unless steps are taken to disable production of that SLP.

20 DNA sequences consisting essentially of the appropriate coding sequences may be produced by ligation. The DNA sequences may be isolated and/or purified for use in the invention. Expression vectors can thus be prepared which incorporate a promoter operably linked to one of these DNA sequences. These vectors are capable of expressing the fusion polypeptide when provided in a suitable host. The vectors are generally plasmids.

25 The coding sequences are located between translation start and stop signals. A ribosome binding site, an origin of replication and, optionally, a selectable marker gene such as an antibiotic resistance gene are typically present. In addition to the promoter, other appropriate transcriptional control elements are provided, in particular a transcriptional termination site. The promoter may be the natural promoter for a SLP protein such as a promoter for a Bacillus SLP, for example for a SLP from B.sphaericus or B.brevis. Typically the promoter is the native promoter for the SLP at least

30

35

the functional portion of which is present in a fusion polypeptide according to the invention. The coding sequences are provided in the correct frame such as to enable expression of the fusion polypeptide to occur in a host compatible with the vector.

5 Transformation of a host cell may be achieved by conventional methodologies. We have found, however, that such methodologies do not work in the case of B. sphaericus P-1. We have devised a new technique for transforming B. sphaericus P-1. Accordingly, the present invention provides a process of transforming B. sphaericus P-1 cells with DNA,
10 which process comprises harvesting B. sphaericus P-1 cells at the late stationary growth phase, mixing the harvested cells with the DNA and effecting electroporation to cause entry of the DNA into the said cells.

Electroporation at the late stationary phase may be effected at from 8 to 16 kV/cm, 150 to 250 Ω and 20 to 40 μ F. Preferred conditions are
15 12kV/cm, 200 Ω and 25 μ F. Electroporation is generally carried out in electrocurvettes, for example 0.1 cm- or 0.2 cm-gapped electrocurvettes.

The transformed host cells are cultured under such conditions that expression of the fusion polypeptide occurs. The invention consequently additionally provides a host cell transformed with a recombinant DNA
20 molecule, typically a vector, according to the invention.

The host cell can be transformed so that none of the native SLP is still produced or so that the native SLP is produced in addition to the fusion polypeptide according to the invention. The invention therefore further provides a host cell which is able to express a fusion polypeptide according
25 to the invention in addition to or instead of the SLP native to the said host cell.

A host cell can therefore be engineered which presents a foreign epitope on its surface as a part of a composite S-layer. The S-layer incorporates the fusion polypeptide. The fusion polypeptide (for example, presenting a
30 foreign epitope) and any native SLP produced by the host cell assemble into a S-layer. We have surprisingly found that fusion of a foreign amino acid sequence to at least a functional portion of a S-layer protein does not prevent the proper folding of the foreign sequence. The foreign sequence is thus presented on the surface of host cell and can be recognised by the
35 immune system of a host, human or animal.

The foreign sequence can also be presented on the surface of sacculi.

- 17 -

Sacculi, sometimes termed native sacculi or ghosts, are devoid of cytosolic and membrane proteins. They consist mainly of the peptido-glycan outer layer of bacterial cells surrounded by the S-layer. They can be derived from host cells according to the invention by simple procedures (Sára and Sleytr, 1987). For example, host cells may be sonicated, a detergent such as Triton X-100 added and the mixture incubated. After washing, the treated cells can then be incubated with DNase and RNase. The resulting sacculi are washed again.

The host cell or sacculi derived therefrom can therefore be used as a vaccine. The host cell may be a non-pathogenic bacterium. It may be a bacterium which is naturally non-pathogenic or it may be an attenuated bacterium for this purpose, i.e. an attenuated form of a pathogenic bacterium. An attenuated bacterium typically contains one or more rationally directed mutations that prevent extensive spreading of the bacterium within the host to which the bacterium is administered. The bacterium can however still establish a limited infection leading to the stimulation of a natural immune response (Charles and Dougan, 1990).

A pharmaceutical or veterinary composition may therefore be provided which comprises a host cell provided with a S-layer comprising a fusion polypeptide according to the invention and a pharmaceutically or veterinarily acceptable carrier or diluent. The composition may be formulated as a vaccine. The composition may be administered orally, intranasally or parenterally such as subcutaneously or intramuscularly. The dosage employed depends on a number of factors including the purpose of administration and the condition of the patient. When the host cell is a bacterium, typically however a dose of from 10^9 to 10^{11} bacteria is suitable for a human or animal for each route of administration.

The composition may be in lyophilized form. The composition may be formulated in capsular form. The capsules may have an enteric coating for oral administration, comprising for example Eudragate "S", Eudragate "L", cellulose acetate, cellulose phthalate or hydroxypropylmethyl cellulose. These capsules may be used as such or alternatively, the lyophilised material may be reconstituted prior to administration, e.g. as a suspension. Reconstitution is advantageously effected in a buffer at a suitable pH to ensure the viability of the organisms. In order to protect the bacteria from gastric acidity, a sodium bicarbonate preparation is advantageously

administered before each administration of the composition.

The presentation system of the invention has applicability beyond use as live bacterial vaccines. The heterologous polypeptides which are presented on the surface of host cells thus remain bound to the cells, so the presentation system may be used for screening proteins and antigens, and the system can also be used as a support for immobilising an enzyme, peptide and/or antigen (Georgiou *et al.*, 1993; Smith *et al.* 1993).

Host cells according to the invention may therefore be used for display of antibodies and peptide libraries. A bacterial selection system complementary to phage display technology can thus be produced. The bacterial library can be separated by affinity chromatography.

A host cell displaying on its surface a heterologous polypeptide of interest can also be used to raise antibody against that polypeptide. Polyclonal antibody can be raised by, for example, administering the host cell to a mammal. The mammal may be an experimental animal such as a rabbit, mouse or rat. Antisera can be obtained from the immunised mammal.

Monoclonal antibodies can be obtained by adaptation of conventional procedures. A mammal is immunised with a host cell according to the invention, cells of lymphoid origin from the immunised mammal are fused with cells of an immortalizing cell line and thus - immortalized cells which produce antibody specific for the heterologous polypeptide of interest are selected. The selected cells are cultured to obtain quantities of the desired monoclonal antibody.

In more detail, hybridoma cells producing monoclonal antibody may be prepared by fusing spleen cells from an immunised animal with a tumour cell. The mammal which is immunised may be a rat or mouse. The hybridomas may be grown in culture or injected intraperitoneally for formation of ascites fluid or into the blood stream of an allogenic host or immunocompromised host. Human antibody may be prepared by *in vitro* immunisation of human lymphocytes with respect to the peptide or a fragment thereof, followed by transformation of the lymphocytes with Epstein-Barr virus.

The presentation system of the invention can further be employed as a whole-cell adsorbent. The expression of a heterologous polypeptide as part of the S-layer fusion polypeptide on the surface of host cells enables the

host cells to be employed as an affinity adsorbent. Host cells may also be used to present an enzyme as the heterologous polypeptide, thus acting as biocatalysts.

As a consequence of cloning and sequencing the gene encoding the SLP of *B. sphaericus* P-1, in another aspect of the invention we have identified
5 three promoters associated with the gene. One of these promoters is capable of directing a three-fold higher expression level than the wild-type promoter. A putative promoter previously indicated by Bowditch *et al* (1989) was found incapable of directing expression.

10 The present invention therefore additionally provides a first promoter having a -35 region of the sequence TTGAAT and a -10 region of the sequence TATATT. The critical parts of promoters are believed to be the -35 and -10 regions (Watson *et al*, 1987). According to the numbering scheme used, the DNA nucleotide encoding the beginning of the mRNA
15 chain is +1.

Typically there are 16 to 18 nucleotides between the -35 and -10 regions. Preferably the intervening nucleotides are
TTCGGAAAAGATAGTGT. A useful promoter has the sequence
CTAAATTTATGTCCCAATGCTTGAATTTTCGGAAAAGATAGTGT
20 TATATTATTGT. The -35 and -10 regions are underlined.

A promoter having -35 and -10 regions of the sequences TTGAAT and TATATT, respectively, is the promoter having a transcription initiation site identified herein as P1 (see Figure 10 of the accompanying drawings). This promoter is capable of directing expression at higher levels than the
25 promoters having transcription initiation sites identified herein as P2 and P3 (Figure 10) or than the entire wild type promoter sequence shown in Figure 10 incorporating all of the three promoters. The P1 promoter is in fact three-fold stronger but only when used alone, i.e. when separated from the P2 and/or P3 promoters.

30 The invention also provides a second promoter having a -35 region of the sequence CTTGGTT and a -10 region of the sequence TATAAT. Typically there are 16 to 18 nucleotides between the two regions. Preferably the intervening nucleotides are ATTATTGAGAGTAAGG. A useful promoter has the sequence
35 TCCAGAAAATGCTTGGTTATTATTGAGAGTAAGGTATAATAGGTA,
the -35 and -10 regions being underlined.

- 20 -

The invention additionally provides a third promoter having a -35 region of the sequence ATTACGGGA and a -10 region of the sequence TTTAGT. Typically there are 16 to 18 nucleotides between the two regions. Preferably the intervening nucleotides are

5 GTCTTTAATTTTGGACAA. A useful promoter has the sequence
AAAATATTACGGGAGTCTTTAATTTTGGACAA TTTAGTAACCAT,
the -35 and -10 regions being underlined.

The three promoters may be tandemly arranged, for example in the order of the third promoter, the second promoter and the first promoter in
10 the 5' to 3' direction. This is the order in which the three promoters occur in the wild-type promoter of B. sphaericus P-1 shown in Figure 10. Useful DNA fragments incorporating the promoters according to the invention are the following DNA sequences shown in Figure 10, using the number system employed in that Figure:

- 15 - nucleotides 52 to 353;
- nucleotides 1 to 353;
- nucleotides 1 to 406; and
- nucleotides 1 to 455.

The promoters can be used to direct expression of a
20 heterologous protein in a host, for example a bacterial host such as a gram-negative or gram-positive bacterium. Suitable host cells are therefore as described above. The invention therefore provides:

- (a) an expression vector which comprises a promoter according to the invention and a downstream cloning site into which a DNA sequence
25 encoding a heterologous protein may be cloned such that the promoter is operably linked to the said sequence;
- (b) an expression vector which comprises a promoter according to the invention operably linked to a DNA sequence encoding a heterologous protein; and
- 30 (c) a DNA fragment comprising a promoter according to the invention operably linked to a DNA sequence encoding a heterologous protein.

An expression vector (a) or (b) can include any suitable origin of replication which will enable the vector to replicate. A ribosome binding site is provided. The ribosome binding site is suitably located between the
35 promoter and the cloning site or the DNA sequence encoding the heterologous protein as the case may be. If desired, a selectable marker

gene such as an antibiotic resistance gene can be provided in the vector.
The vector is generally a plasmid.

The cloning site of vector (a) may be provided at a translational start
codon such as a NcoI site. Alternatively, no translational start codon may
5 be provided in the vector. In that event, the foreign gene to be inserted into
the cloning site would need to be provided with such a codon. Typically
the gene inserted into the cloning site is provided with a translational stop
codon.

Both vectors (a) and (b) are normally provided with a transcriptional
10 termination sequence. The DNA sequences of vector (b) and of the DNA
fragment mentioned above are provided with translational start and stop
codons. As in the case of vectors (a) and (b), the DNA fragment will
typically incorporate a ribosome binding site downstream of the promoter.
The DNA fragment may be single- or double- stranded, depending on its
15 purpose.

Vectors (a) and (b) may be constructed by assembling all appropriate
elements using techniques known in the art (Maniatis *et al*, 1982). For
example, vector (b) may be obtained by cloning a DNA sequence encoding
a heterologous protein into vector (a) at the cloning site of that vector or by
20 cloning a DNA fragment (c) into an expression vector provided with an
origin of replication. The cloning site of vector (a) may be introduced by
oligonucleotide-directed mutagenesis or polymerase chain reaction (PCR) -
mediated site specific mutagenesis. The elements of vectors (a) and (b) are
operably linked. The recombinant DNA fragment (c) may be constructed
25 by ligating a foreign gene to a promoter sequence according to the
invention.

The DNA sequence encoding a heterologous protein may be provided
immediately downstream of a DNA sequence encoding a signal peptide
responsible for polypeptide secretion which in turn may be provided
30 immediately downstream of the translational start codon. The signal
peptide-encoding DNA sequence may encode any signal peptide capable of
directing secretion of polypeptides from gram-positive bacterium. Typically
the amino acid sequence of the signal peptide ends ValAlaSerAla.

The heterologous protein may be a heterologous peptide as described
35 above.

The following Examples illustrate the invention. In the accompanying

drawings:

Figure 1 shows the characterization of pGVP1.

A. Restriction map of pGVP1 for HindIII (1), PstI (2), SspI (3), that have double-occurring restriction sites. The single-occurring sites are indicated on the outside of the map.

B. Identification of a circular single-stranded DNA molecule as a replication intermediate of pGVP1.

Panel 1. Ethidium bromide-stained 1% agarose gel. Lane A, non-digested total DNA of B. sphaericus P-1; lane B, HhaI digested P-1 total DNA; lane C, S1 nuclease-treated P-1 total DNA; lane D, P-1 total DNA treated with T₄ DNA polymerase.

Panel 2. Hybridization between ³²P-labelled pGVP1 and a non-denatured Southern blot of the gel in panel 1 on a nitrocellulose membrane. A specific hybridization signal, corresponding to single-stranded DNA, was observed only in non-digested (lane A) and T₄ DNA polymerase-treated P-1 DNA (lane D), but not in HhaI (lane B) or S1 nuclease-treated total P-1 DNA (lane C).

Panel 3. Hybridization between ³²P-labelled pGVP1 and a Southern blot of a similar gel as in panel 1, but denatured prior to transfer to a nitrocellulose membrane. In all lanes, a hybridization signal, corresponding to double-stranded DNA can be observed. In lanes A and D, additionally the signal corresponding to single-stranded DNA can be observed.

Figure 2 shows the results of plasmid analysis of Em-resistant B. sphaericus P-1 transformed by pIL253. Central panel. HindIII-digested plasmid preparations of Em^R B. sphaericus P-1, transformed by pIL253 (lanes 1-4), separated by agarose gel electrophoresis (ethidium bromide stained). Left panel. Autoradiogram of the hybridization between ³²P-labelled pIL253 and a Southern blot of the gel in the central panel. In all transformants, fragments specific for the introduced pIL253 plasmid (3.9 kb and 0.9 kb) are revealed. Right panel. Autoradiogram of the hybridization between the same blot as in the left panel, and ³²P-labelled pGVP1. Specific fragments (2.3-0.5 kb) from the endogenous pGVP1 are revealed.

Figure 3 demonstrates the electrocompetence in B. sphaericus P-1 in late-stationary phase. B. sphaericus P-1 cells were incubated at 37°C in 100 ml LB broth on a gyratory shaker for 48 hr. Every 6 hr a sample was

withdrawn from the culture and colony-forming units/ml were determined. Cells were pelleted by centrifugation, washed and resuspended in 1 ml of distilled H₂O. After addition of pIL253 DNA, cells were electroporated in 0.2 cm gapped electrocuvettes (E₀ 12 kV/cm, R= 200 Ω), diluted in 900 μl

5

LB, incubated for 1 hr at 37°C and plated on LB plates with erythromycin. Figure 4 is a schematic representation of the high-copy number (pSL40) (A) and low-copy number (pSL84) (B) bifunctional vectors for E. coli and B.sphaericus spp. Restriction sites are indicated with their relative position on the physical map. Abbreviations used: bla: β-lactamase; MLS:

10

resistance to the macrolide-lincosamide-streptogramin B group of antibiotics; Orf E to G: open reading frames involved in replication in Gram-positive hosts. pSL40 was constructed by ligating the 2.6-kb EcoRI/XbaI fragment of pLK68 in pIL253 (EcoRI/XbaI-linearized). After restriction and filling-in at the EcoRI site of the resulting plasmid, the small multicloning site was exchanged for the polylinker of pJB66 by substituting the respective

15

XbaI/BglII fragments. pSL84 was constructed by substituting the 1.8-kb PstI/SalI fragment of pSL40 for the 1.3-kb PstI/SalI fragment of pACYC177 (containing the low copy number origin of replication for E. coli). In the resulting plasmid the 2.3-kb NsiI/XbaI fragment was replaced

20

by the corresponding NsiI/XbaI fragment of pIL252 containing the low-copy number origin of replication for Bacillus spp. Figure 5 is a restriction map of the genomic region containing the gene encoding the S-layer protein of B. sphaericus P-1. The black bar represents the signal peptide-encoding sequence; the hatched bar shows the mature part of SLP. The inserts of the four overlapping subclones used for

25

sequence analysis are depicted below the restriction map by open bars. The arrow indicates the direction of transcription.

Figure 6 shows the DNA sequence and deduced amino acid sequence of the slp gene of B.sphaericus P-1. The putative ribosome-binding site preceding the SLP ORF is double underlined. The shaded residues represent the signal peptide. The mature SLP thus commences with amino acid residue 31. Potential N-linked glycosylation sites are underlined. The stem of the Rho-independent transcription termination signal after the translation stop codon is indicated by arrows. The NH₂-terminal amino acid sequence determined by automated microsequence analysis of the purified

30

35

mature SLP is indicated by a dotted line.

- 24 -

Figure 7 shows the hydropathic profile of the *B. sphaericus* P-1 S-layer protein by the computerized method of Kyte and Doolittle (1982).

Horizontal bars represent potential transmembrane helices, as predicted by the method of Rao and Argos (1986).

5 Figure 8 shows the sequence of the NH₂-terminal portion of the SLP of *B. sphaericus* P-1 and the larvicidal strain 2362. The signal peptide sequence of both proteins is boxed. Adjustments (horizontal bars) were introduced for optimal alignment.

Figure 9 :

10 A. Northern blot analysis of the *slp*-encoded mRNA in *B. sphaericus* P-1. Total cellular RNA was isolated from different growth phases (see text). The internal 1.81 kb HpaI fragment of the *slp* gene was used for the generation of a ³²P-labelled probe. Migration pattern of molecular mass markers as indicated.

15 B. Primer extension analysis of the transcriptional initiation sites of the *slp*-encoded transcripts. Two different primers were used (see Figure 10 and text for more details).

20 Figure 10 shows the DNA sequence of the promoter region controlling *slp* expression. The position of the 5' ends of the transcripts, as determined by primer extension analysis, are indicated (black inverted triangles). The putative ribosome-binding site, preceding the *slp* ORF (shaded sequence) is indicated by dots. Primers used for primer extension assays were complementary to the overlined sequences. The exact end points of the different deletion mutants (pSL151 to pSL159) are shown by an arrow.

25 Potential -10 and -35 boxes preceding the transcription initiation sites are indicated. The putative -10 and -35 regions as reported by Bowditch *et al.* (1989) are marked by an asterisk.

30 Figure 11 shows how β -glucuronidase activity is directed by the different *slp* promoter deletion mutants in *B. sphaericus* P-1 (hatched bars). In pSL87 the *uidA* gene is under control of the 138 σ promoter.

35 Figure 12 shows the effect of Ca²⁺ cations on the *slp* promoter-directed β -glucuronidase activity in different deletion mutants. Black bars represent *B. sphaericus* P-1 cells grown in LB medium. Hatched bars indicate cells grown upon addition of 7 mM CaCl₂. Activity was measured 4 hours after addition of CaCl₂ to the culture.

Figure 13 shows the general outline of the strategy for disruptive single

homologous recombination. AB_1^R : antibiotic resistance marker 1 (Em^R); AB_2^R : promoterless antibiotic resistance gene 2 ($nptII$); ori: origin of replication; wavy line: RNA transcript; P: promoter.

Figure 14:

- 5 A. Restriction map of the bifunctional plasmid pSL64 used as based for the construction of different intermediate vectors. Restriction sites are indicated with their relative position on the physical map. Abbreviations used: bla: β -lactamase; MLS: resistance to the macrolide-lincosamide-streptogramin B group of antibiotics; OrfE to
- 10 G: open reading frames involved in replication in Gram-positive hosts (Swinfield *et al.*, 1990).
- B. Nucleotide sequences upstream from the $nptII$ -coding region (boxed) of pSL64 and pSL101.

Figure 15 :

- 15 A. Schematic representation of carboxy-terminal truncated SLPs obtained by single homologous recombination of the different intermediate vectors. Central block represents the restriction map of the chromosomal region containing the *slp* gene. Hi: HindIII; Hp: HpaI; Bg: BglII; Pv: PvuII; Xb: XbaI. Black arrows represent SLPs in the wild-type and recombinant P-1 strains as indicated on the left. Calculated molecular masses of the SLPs are indicated on the right. Striped bars indicate the used subclones of *slp* gene. White bars indicate internal *slp* fragments, cloned in pSL64 in the different intermediate vectors.
- 20
- 25 B. SDS-PAGE of proteins from wide-type P-1 (lanes A), recombinant strains P-1::pSL66 (lanes B), P-1::pSL68 (lanes C) and P-1::pSL69 (lanes D). lane M: high-molecular mass markers (Bio-Rad). Proteins are either TCA-precipitated from the supernatant of the cultures or are obtained by sonication and centrifugation. The insoluble fraction is
- 30 indicated by debris, whereas the soluble fraction is indicated as sonicate.

Figure 16 is an autoradiogram of the hybridization between ^{32}P -labelled pSL20 and BglII-digested total DNA of P-1 (lane A), P-1::pSL69 (lane B), and P-1:: pSL102 (lane C). In P-1:: pSL69 and P-1::pSL102, the 1600 BP BglII fragment, hybridizing with P-1 total DNA has disappeared, whereas

35 two predicted fragments of 2600 and 6500 bp appeared.

- 26 -

Figure 17 is a schematic representation of the peptides translationally fused to carboxy-terminally truncated SLPs in the strains P-1::pSL102, P-1::pSL113 and P-1::pSL111. Central block represents the restriction map of the chromosomal region containing the *slp* gene, Hi: HindIII; Hp: HpaI; Bg: BglIII; Pv: PvuII; Xb: XbaI. Arrows under the restriction map represent recombinant SLPs after integration of intermediate vectors indicated above the restriction map. Black fragments represent SLP portion, striped bars indicate the S1 subunit of pertussis toxin, and white bars represent NPTII.

10 Figure 18 :

- A. SDS-PAGE of total protein extract from P-1::pSL113 (lane 1), P-1::pSL102 (lane 2), and P-1::pSL69 (lane 3). Respective SLPs are indicated by a (130 kDa), b (102 kDa) and c (74 kDa).
- B. Immunodetection on a Western blot of the gel in panel A, using anti-NPTII antibodies. Two recombinant SLPs (indicated a and b) are revealed.
- C. SDS-PAGE of total protein extract from P-1::pSL111 (lanes 1-3), P-1::pSL102 (lane 4) and P-1::pSL69 (lane 5).
- D. Immunodetection on a Western blot of the gel in panel C, using anti-PT antibodies. Two recombinant SLPs (of 90 and 120 kDa) are revealed (d* and d, respectively).

Figure 19 is an autoradiogram of in gel kanamycin phosphorylation assay on protein extracts separated by non-denaturing polyacrylamide gel electrophoresis extracted from P-1 (panel A) P-1::PSL69 (panel B), and P-1::pSL102 (panel C). Significant phosphorylating activity in the high-molecular mass region can only be observed in P-1::pSL102.

Figure 20 shows immunogold labelling on intact bacteria using anti-NPTII antibodies. Panel A, P-1::pSL69, panel B, P-S::pSL102; panel C, P-2::pSL113. Significant accumulation of gold-label can only be observed in P-a::pSL102 and to a lesser extent in P-1::pSL113.

Figure 21 shows the detection of PT subunit S1 and NPTII in native sacculi prepared from P-1::PSL102 and P-1::pSL111. CE: cellular extracts; NS: native sacculi.

Example 1

1. Materials and Methods

Bacterial strains and plasmids. In Table I, the bacterial strains and

- 27 -

plasmids used in this study are listed. B. sphaericus strains were grown in Luria-Bertani (LB) broth (Miller, 1972), supplemented with 0.7% agar for solid media. Selective antibiotic concentrations for B. sphaericus were: 10 $\mu\text{g/ml}$ erythromycin (Em); 10 $\mu\text{g/ml}$ nalidixic acid (Na). For E. coli, 200 $\mu\text{g/ml}$ of triacillin was used.

Table I.

Bacterial strains and plasmids used in this study

Characteristics		References
<u>E. coli</u>		
DH5 α	F ⁻ , ϕ 80dlacZ Δ M15, Δ (lacZYA-argF) _{U169} , recA1, endA1, hsdR17(r _k ⁻ , m _k ⁺), supE44	Hanahan (1983)
MC1061	hsdR, hsdM, hsdS, araD139, Δ (ara-leu) ₇₆₉₇ , Δ lac _{x74} , galU, galK, rpsL	Casadaban and Cohen (1980)
<u>B. sphaericus</u>		
P-1	Nalidixic acid resistant	Lewis <i>et al.</i> (1987)
1593		BGSC
10208		ATCC
<u>Lactococcus lactis</u>		
MG1363		Gasson and Davies (1980)
<u>Plasmids</u>		
pGVP1	natural isolate in <u>B. sphaericus</u> P-1	This study
pGVP2	cointegrate of BamHI-linearized pUC9 and BglII-linearized pGVP1	This study
pUC9	Ap ^R	Vieira and Messing (1982)
pPGV5	bifunctional, Ap ^R , Nm ^R	This study
pJB66	Ap ^R	Botterman and Zabeau (1986)
pSL40	cointegrate of pJB66 and pIL253, Ap ^R , MLS ^R	This study
pSL84	cointegrate of pACYC177 and pIL252, Ap ^R , MLS ^R	This study
pAM β 1	MLS ^R , autotransmissible, natural isolate	Clewell <i>et al.</i> (1974)
pIL252	MLS ^R , low-copy number vector derived from pAM β 1	Simon and Chopin (1988)
pIL253	MLS ^R , high-copy number vector derived from pAM β 1	Simon and Chopin (1988)
pACYC177	Ap ^R , Km ^R , low-copy number vector	Chang and Cohen (1978)

- 29 -

Transformation and plasmids. Competent *E. coli* strains were prepared and transformed according to Kushner (1978). Transformation of *B. sphaericus* P-1 intact cells was achieved by electroporation using the protocol developed as described in the Results section below. *B. sphaericus* P-1 cells, grown in LB broth for 42 hr at 37°C on a gyratory shaker, were harvested by centrifugation (9000 g), washed with ice-cold distilled H₂O, resuspended in 1/10 volume of a 10% glycerol solution in distilled H₂O, aliquoted in 100 µl samples, and stored at -70°C.

For transformation, samples were quickly thawed, mixed with DNA, and transferred into 0.1 cm gapped electrocuvettes. An electrical pulse (14 kV/cm, 25 µF) was delivered, using a GenePulser (Trade Mark) apparatus (Bio-Rad laboratories) with Pulse Controller extension set at 200 Ω. After the electrical pulse was delivered, cells were diluted with 900 µl of LB broth and incubated at 37°C for 1 hr, prior to plating on solid LB medium, and supplemented with appropriate antibiotics.

General recombinant DNA techniques. *E. coli* plasmid DNA was prepared according to Sambrook *et al.* (1989), whereas for plasmid and total DNA preparations of *B. sphaericus*, cells were pretreated with lysozyme (100 µg/ml) at 37°C for 10 min. Restriction enzymes were purchased from New England Biolabs, Pharmacia (Uppsala, Sweden) or Bethesda Research Laboratories, and were used according to the manufacturers' recommendations.

Elution of DNA restriction fragments was done using GeneClean II (Trade Mark) kit (Bio101 Inc., La Jolla, California, US). Filling-in of protruding single-stranded termini after restriction enzyme digestion (using Klenow or T₄ DNA polymerase) and ligations were done according to standard conditions (Sambrook *et al.*, 1989). Southern transfer and hybridization were performed using Hybond N⁺ membranes (Amersham) and QuickPrime (Trade Mark) labelling kit (Pharmacia) to prepare ³²P-labelled probes, except for blotting of single-stranded DNA, which was achieved using nitrocellulose membranes.

2. Results

Characterization of endogenous plasmids of *B. sphaericus* P-1. Plasmid preparations, according to the alkaline lysis method, followed by equilibrium density gradient centrifugation, revealed the presence of a small plasmid (2.8 kb), designated pGVP1, in *B. sphaericus* P-1. By preliminary

restriction analysis of pGVP1, a unique restriction site for BglIII was found. For further restriction enzyme analysis, a cointegrate plasmid (pGVP2) was constructed, by joining BglIII-linearized pGVP1 and BamHI-linearized pUC9, allowing large-scale preparations from *E. coli*. Single- and double-occurring restriction enzyme sites (BglIII, AvaI, NcoI, PstI, HindIII, SspI) were ordered by appropriate double digestions (Fig. 1A). No sites were found for KpnI, BamHI, EcoRI, ApaI, ClaI, EcoRV and SphI.

Hybridizations were performed between ³²P-labelled pGVP1 and Southern transfers of non-denatured total DNA of *B. sphaericus* P-1 to nitrocellulose membranes (a frequently used method for detection of single-stranded replication intermediates in Gram-positive replicons; Gruss and Ehrlich, 1989). A specific hybridization signal was observed in undigested total DNA (Fig. 1B, panel 2, lane A), corresponding to a single-stranded intermediate. The signal was not detected in DNA samples which were digested either with S1 nuclease or with the single-stranded DNA-cleaving endonuclease HhaI, prior to gel separation.

Treatment with T₄ polymerase, which degrades specific linear single-stranded DNA, did not decrease the signal, indicating that the pPGV1 replication intermediate is circular. As it is of considerable interest to use *B. sphaericus* P-1 as a host for transformation experiments several methods for plasmid curing that proved successful in Gram-positive bacteria [including novobiocin (González et al., 1981), rifampin (Johnston and Richmond, 1970), sodium dodecyl sulfate (Sonstein and Baldwin, 1972)] were tried out but did not result in the production of a plasmid-free strain.

Introduction of pAMβ1 into *B. sphaericus* P-1 by intergeneric conjugation. To test whether the macrolide lincosamide streptogramin B (MLS) resistance determinant and the origin of replication of the auto-transmissible plasmid pAMβ1 (26.5 kb) were functional in *B. sphaericus* P-1, this plasmid was introduced into P-1 by conjugating it with *Lactococcus lactis* MG1363 [pAMβ1] (Gasson and Davies, 1980). This plasmid was chosen because it had previously been introduced successfully into *B. sphaericus* 1593 (Orzech and Burke, 1984). After overnight incubation of a mixture of both strains (ratio 1:1) on nitrocellulose filters placed on M17⁺ lactose medium at 37°C, bacteria were collected and several dilutions were plated on LB medium supplemented with Em.

Em-resistant *B. sphaericus* P-1 colonies were obtained at a frequency of

3 x 10⁻⁶ (transconjugants/acceptor strain). After colony purification on LB medium supplemented with erythromycin and nalidixic acid, putative transconjugants were analyzed for the presence of pAM β 1 by Southern hybridization using ³²P-labelled pAM β 1 as a probe (data now shown). The plasmid was stable for several generations, even in the absence of selective pressure. These results prompted us to use pAM β 1-derived cloning vectors (e.g. pIL253) for electrotransformation experiments in P-1.

Electrotransformation. Initial experiments using pIL253 to transform B. sphaericus strains, following reported protocols for electrotransformation of several Bacilli (Takagi *et al.*, 1989; Bone and Ellar, 1989; Taylor and Burke, 1990) were unsuccessful. The common denominator in these protocols is the use of cells harvested in early or mid-log growth phase. However, using cells harvested from late-log solid-grown colonies, which were washed once with ice-cold distilled H₂O, and standard electrical parameters for E. coli (12kV/cm, 200 Ω , 25 μ F in 0.2 cm gapped electrocuvettes), 10² transformants were obtained. Plasmid analysis revealed the presence of two plasmids that could be identified as the endogenous pGVP1 and the introduced pIL253 by Southern hybridization (Fig. 2).

To optimize the physiological conditions for electroporation of P-1, cells harvested at different time-points in a growing culture were washed once and resuspended in 1/10 volume distilled H₂O, and electroporated (at 12 kV/cm, 200 Ω , 25 μ F in 0.2-cm gapped electrocuvettes). Although growth of the culture stagnated after 8 hr, transformants were not obtained until 36 hr of incubation. The number of transformants reached a maximum at 42 hr incubation, and significantly decreased after 48 hr of incubation, presumably due to cell death (Fig. 3). This phenomenon demonstrates the need for a certain physiological state of the bacterial cells required for electrotransformation, or in other words electrocompetence.

Electrocompetence has been inferred to explain saturation of transformation efficiencies at increasing DNA concentration (Chassy *et al.*, 1988; Desomer *et al.*, 1990).

Addition of different chemicals (used to increase transformation efficiency in protocols for different bacterial species) to the electroporation medium, such as polyethylene glycol (PEG) 1000 (15% w/v) and glycerol (10% w/v) improved the transformation efficiency significantly. (Table II).

Variation of the electrical parameters included transformation at higher voltages (12, 14 and 16 kV/cm in 0.1-cm gapped electrocuvettes) and use of different external resistances (200, 400 and 600 Ω). Maximum transformation efficiencies were obtained at 14 kV/cm, 25 μ F, 200 Ω using
5 0.1-cm gapped electrocuvettes (Table II below).

Combination of both improved protocols, as described in the Materials and Methods section above, routinely yielded 10^5 transformants per μ g DNA. Cells could be kept frozen at -70°C without significant loss of electrocompetence.

10 The high transformation efficiency obtained by this protocol prompted us to test whether plasmids with single-stranded replication intermediates (such as the pUB110-derived vector pPGV5) could be used as transforming DNA, and eventually yield a P-1 strain, cured of pGVP1 by incompatibility. pPGV5 is a cointegrate via the EcoRI site of pUC4 (Vieira and Messing,
15 1982) and pPL703 (Mongkolsuk *et al*, 1983). Nm-resistant transformants were obtained with low frequency (Table II below) and contained intact pPGV5 in addition to the endogenous pGVP1 (data not shown).

Application of the same protocol to B. sphaericus 1593 and ATCC 10208 yielded no transformants (Table II below). Indeed, a previously
20 published protocol for electrotransformation for B. sphaericus 1593 used cells harvested in early-log growth-phase (Taylor and Burke, 1990).

Construction of bifunctional vectors for E. coli and B. sphaericus.
Bifunctional vectors that can replicate in both B. sphaericus and E. coli
25 have the advantage that cloning procedures and analysis can be done with well established methods in E. coli prior to introduction of the final construct into B. sphaericus. Bifunctional plasmids were constructed with high- (pSL40) and low-copy number (pSL84) in both hosts. pSL40 contains the multilinker, ampicillin-resistance gene and the ColE1 origin of replication of pJB66 (Botterman and Zabeau, 1980) as well as the MLS
30 determinant and origin of replication of pIL253 (Fig. 4A). In pSL84, the high-copy number origin of replication of pJB66 is exchanged for the low-copy number origin of pACYC177, whereas the origin of pIL253 is replaced for that of pIL252, an ancestral plasmid of pIL253 with low-copy number (Fig. 4B). Upon introduction in B. sphaericus P-1, both plasmids
35 exhibited the expected copy number control. No significant difference in transformation efficiency was observed using pSL40 or pSL84 prepared

from either the E. coli MC1061 or the B.sphaericus P-1 hosts (Table II below).

Table II
Transformation efficiencies using different electrical conditions, B. sphaericus strains and plasmids

Strain	Electroporation medium	E ₀ kV/cm	R Ω	Plasmid	Transformation efficiency ^d
P-1	H ₂ O	0	200p	IL253	< 10 ¹
P-1	H ₂ O	6	200	pIL253	2.0 x 10 ¹
P-1	H ₂ O	10	200	pIL253	3.4 x 10 ²
P-1	H ₂ O	12	200	pIL253	8.5 x 10 ²
P-1	H ₂ O	12 ^a	200	pIL253	9.6 x 10 ³
P-1	H ₂ O	14 ^a	200	pIL253	6.7 x 10 ³
P-1	H ₂ O	16 ^a	200	pIL253	8.6 x 10 ²
P-1	H ₂ O	14 ^a	400	pIL253	5.3 x 10 ³
P-1	H ₂ O	14 ^a	600	pIL253	4.7 x 10 ²
P-1	30% PEG1000	12	200	pIL253	< 10 ¹
P-1	15% PEG6000	12	200	pIL253	4.0 x 10 ¹
P-1	15% PEG1000	12	200	pIL253	2.4 x 10 ²
P-1	10% glycerol	12	200	pIL253	1.4 x 10 ³
P-1	10% glycerol	14 ^a	200	pIL253	6.5 x 10 ⁵
P-1	H ₂ O	12	200	pPGV5 ^b	8.0 x 10 ¹ °
1593	H ₂ O	12	200	pIL253	< 10 ¹
10208	H ₂ O	12	200	pIL253	< 10 ¹
P-1	10% glycerol	14 ^a	200	pSL40	2.0 x 10 ³
P-1	10% glycerol	14 ^a	200	pSL40 ^b	2.6 x 10 ³

^a in 0.1-cm gapped electrocuvettes; ^b plasmid source was E. coli; ^c selected on LB with Nm; ^d number of transformants selected on LB EM per μg of DNA.

5

Example 2

1. Materials and Methods

Bacterial strains, plasmids and media. Bacterial strains used are B.sphaericus P-1 (Lewis et al., 1987) and B.subtilis BR151 (Bacillus Genetic Stock Center, Ohio State University, Columbia). E. coli hosts were either DH5α (Hanahan, 1983) or MC1061 (Casadaban and Cohen, 1980). Cloning was performed in pUC18 (Yanisch-Perron et al., 1985). pSL40 (Example 1) is a high copy number E. coli-Bacillus shuttle vector, essentially composed of pJB66 (Botterman and Zabeau, 1987) and pIL253 (Simon and Chopin, 1988). The β-glucuronidase (uidA) gene cassette was isolated from pGUS1 (Peleman et al., 1989) and introduced into pSL40 as a BamHI/SphI fragment, yielding pSL150. Bacteria were grown on LB

15

medium (Miller, 1972) solidified with 1.5% agar, whereas liquid cultures were grown in TB medium (Tartof and Hobbs, 1987). When required antibiotics were added: ampicillin (100 μ g/ml) or erythromycin (10 μ g/ml). All cultivations were performed at 37°C.

5 DNA techniques. Recombinant DNA techniques for E. coli were performed according to standard conditions (Sambrook et al, 1989). Restriction and modifying enzymes were purchased from Pharmacia, New England Biolabs, Promega or Bethesda Research Laboratories and used according to their recommendations. DNA fragments were purified from
10 agarose gel using the Gene Clean Kit (Bio-101 Inc.). DNA sequences from both strands were determined by the dideoxy-chain termination method (Sanger et al, 1977) using the T7 Sequencing Kit (Pharmacia). Sequence analysis was carried out with the Intelligenetics suite of program (Intelligenetics Inc.). Databases were screened by FASTDB software
15 (Brutlag et al, 1990). Unidirectional deletions were generated by combined ExoIII/S1 nuclease activity, using the Double-stranded Nested Deletion Kit (Pharmacia). Oligonucleotides were synthesized on an ABI 394 DNA/RNA Synthesizer (Applied Biosystems Inc.). High voltage transformation of E. coli DH5 α with ligation mixtures was done with a Bio-Rad Gene Pulser
20 (Trade Mark). Site-specific mutagenesis using polymerase chain reaction (PCR) was performed as described (Landt et al, 1990).

Construction and screening of libraries. B. sphaericus P-1 genomic DNA was prepared as described by Mielenz (1983) and digested to completion with the appropriate restriction enzyme. Libraries were
25 constructed in digested and dephosphorylated pUC18, according to standard conditions (Sambrook et al, 1989). 3840 colonies were transferred to Hybond-N nylon membranes (Amersham International) and screened by colony hybridization under standard stringency conditions. ³²P-labelled probes were generated using the ³²P-Quick Prime (Trade Mark) Kit
30 (Pharmacia).

RNA analysis. Total RNA was extracted from B. sphaericus P-1 by the hot-phenol method of Aiba et al (1981). Total RNA isolated at different growth phases was run on a formaldehyde containing agarose gel and transferred to Hybond-N nylon membranes (Pharmacia) and hybridized
35 according to the manufacturer's recommendations. Single stranded oligonucleotides (Figure 10) were used as primers in a primer extension

assay. 50 μ g of RNA was mixed with 50 ng primer and ethanol-precipitated. The pellet was resuspended in 20 μ l 5 x hybridization buffer (2 M NaCl, 50 mM PIPES pH 6.4, 5 mM EDTA) and 80 μ l deionized formamide and incubated for 15 minutes at 85°C. Primer annealing
5 proceeded over-night at 37°C. Primed RNA was ethanol-precipitated. The extension reaction was carried out for 90 minutes at 42°C in a 40 μ l mixture containing 50 mM Tris.HCl (pH 8.2), 10 mM dithiothreitol, 6mM MgCl₂, 25 μ g/ml actinomycin D, 250 μ M dCTP, dGTP, dTTP, 150 μ M dATP, 60 μ Ci [α -³⁵S] dATP (Amersham International) and 40 units Reverse
10 Transcriptase. Upon completion of the reaction 2 μ l pancreatic RNase (1 mg/ml) was added and incubated for another 20 minutes. Extension products were purified by phenol/chloroform extraction and subsequent ethanol precipitation. The size of the extended products was deduced by comparison to a corresponding sequence ladder, generated with the same
15 primer.

Protein micro-sequence analysis. The surface-layer protein from B. sphaericus P-1 was isolated from cell walls by urea extraction as described by Lewis et al (1987). Upon sodium dodecyl sulfate polyacrylamide gel electrophoresis (SDS-PAGE) proteins were electro-blotted and immobilized
20 on a treated glass fibre plate (Bauw et al, 1987) for NH₂-terminal amino acid sequence determination on an automated ABI 473A Protein Sequencer (Applied Biosystems Inc.).

Enzyme assay. β -glucuronidase activity was measured essentially as described (Jefferson et al, 1986) using p-nitrophenyl- β -D-glucuronide as
25 substrate. Cells were resuspended in 1 ml reaction buffer, supplemented with 0.01 % SDS. Permeabilization of bacterial cells was achieved by addition of 25 μ l chloroform and vortexing for 10 seconds. After termination of the reaction, cells were pelleted and the cleared supernatant was used for O.D. measurement.

30 2. Results

Identification and cloning of the slp gene. The surface-layer protein of B. sphaericus P-1 was purified and subjected to automated microsequence analysis. 21 NH₂-terminal amino acid residues could be deduced: NH₂-Ala-Gln-Val-Asn-Asp-Tyr-Asn-Lys-Ile-Ser-Gly-Tyr-Ala-Lys-Glu-Ala-Val-Gln-
35 Ala-Leu-Val. Based on residues 11 to 19 of this sequence, a specific oligodeoxynucleotide probe mixture was synthesized with the following

- 36 -

sequence : 5'-GCYTGIACIGCYTCYTTIGCITAICC-3' wherein Y is C or T, and wherein I is inosine. Several unique bands were revealed on Southern blots of restricted genomic DNA when hybridized to the ³²P-labelled oligonucleotide probe.

5 A preliminary restriction map was established from which it was deduced that the 5.0-kb EcoRI fragment very probably contained the complete slp gene. An EcoRI-generated library of B. sphaericus P-1 genomic DNA in pUC18 was screened by colony hybridization. Despite the use of different hybridization conditions no subclones containing the 5.0-kb
10 fragment could be isolated, suggesting that cloning of the entire gene or a large part of it in E. coli is lethal to the host. Therefore cloning of smaller restriction fragments, identified in the Southern blot analysis, was pursued.

Screening of a HindIII-generated library resulted in the isolation of a pUC18 clone (pSL1), containing a 1.8-kb insert. Further analysis showed
15 that the homology could be delineated to a small 100-bp HindIII/PvuII fragment. Sequence analysis confirmed this homology: the deduced amino acid sequence of this region completely matched the sequence as obtained after microsequencing of the SLP subunit. Preceding this region a typical signal peptide sequence for secretion was detected. The pSL1 clone thus
20 contains the slp promoter and a stretch encoding a 30-residue signal peptide and the first 20 amino acid residues of the SLP of B. sphaericus P-1.

It also became clear that the originally identified 5.0-kb EcoRI fragment indeed contained the complete slp gene, including its own promoter. However due to inability to clone this fragment in E. coli, we were obliged
25 to isolate the gene as a set of overlapping clones. In this way, three other pUC18 clones were isolated from several libraries using the previous fragment as probe: pSL4, containing a 0.8-kb PvuII fragment; pSL10, harbouring a 1.6-kb BglII fragment and pSL20 carrying a 3.0-kb HindIII fragment (Figure 5). In total a region of 4.6 kb was spanned from which
30 the DNA sequence was determined (Figure 6).

The slp gene sequence. Analysis of the DNA sequence starting from the EcoRI site to the most downstream HindIII site revealed an open reading frame (ORF) of 3756 nucleotides, starting at the ATG initiation codon
(position 95 to 97; Figure 6) and terminating at the stop codon TGA
35 (position 3851 to 3853; Figure 6), whereas as many as 256 translation stop codons are dispersed over the 2 other reading frames. This ORF could

encode a polypeptide of 1252 residues with a deduced molecular mass of 130,060 Da, which is 20 kDa less than the value deduced from SDS-PAGE. This discrepancy is probably due to the fact that the *B. sphaericus* P-1 SLP is glycosylated (Lewis *et al.*, 1987). Indeed, 20 potential N-linked
5 glycosylation sites are distributed over the sequence. The protein has a calculated pI value of 4.59, which is in accordance with the experimentally determined value of 4.6 ± 0.4 (Lewis *et al.*, 1987).

The 3' end of the ORF is followed by a palindrome with a stem of 13 base pairs (position 3904 to 3933; Figure 6) and a thymidine-rich stretch,
10 which is typical for a Rho-independent transcription termination signal (Platt, 1986). The start codon ATG is preceded by a potential ribosome-binding site 5'-AGGGAGG-3' (position 78 to 85; Figure 6). The 11 nucleotide-spacing between the middle A of this motif and the ATG codon is typical of that found in gram-positive bacteria (Hager and Rabinowitz,
15 1985).

The deduced amino acid sequence was analyzed by the computerized method of Kyte and Doolittle (1982) for hydrophobicity (Figure 7). The NH₂-terminal sequence (30 residues) appears to be very hydrophobic, which is in accordance with the presence of a signal peptide responsible for
20 secretion. It moreover ends by the sequence VASA, a motif frequently recognised by signal peptidases (von Heijne, 1986) and is then directly followed by the sequence determined by microsequence analysis of the mature SLP subunit. Several other hydrophobic regions, which might interfere with membrane translocation were observed at the COOH-terminus
25 (Figure 7).

Table III shows the amino acid composition of the SLP, which shares several features with other S-layer proteins. The only sulphur-containing amino acid is methionine (2 residues). It contains a high proportion of hydrophobic amino acids (38%), but it is not very enriched in acidic
30 residues (10.6%) versus basic residues (8.3%), as is the case for the two S-layer proteins of *B. brevis* 47 (Tsuboi *et al.*, 1988). No significant homology to other S-layer proteins was found, except with the SLP of *B. sphaericus* 2362 (Bowditch *et al.*, 1989), at the level of the NH₂-terminal sequence (Figure 8). The first 200 residues show a degree of 82% identity.
35 However, no homology downstream of this region could be detected. This observation was confirmed by comparing the hydrophobicity plots of both

proteins (data not shown).

Table III
Amino acid composition of the *B. sphaericus* P-1 SLP

Amino Acid	Number	% (molecular mass)
Threonine	166	12.8
Valine	134	10.2
Alanine	181	9.9
Lysine	91	9.0
Asparagine	88	7.7
Glutamic acid	69	6.9
Leucine	64	5.6
Aspartic acid	62	5.5
Phenylalanine	47	5.3
Serine	78	5.2
Isoleucine	55	4.8
Tyrosine	37	4.6
Glycine	95	4.2
Glutamine	34	3.4
Proline	31	2.3
Arginine	11	1.3
Tryptophan	6	0.9
Methionine	2	0.2
Histidine	1	0.1
Cysteine	0	0.0

The *slp* promoter. In order to examine how the *slp* gene is transcribed in vivo total RNA was isolated at different growth phases: early and middle logarithmic phase, early stationary phase and from an overnight saturated culture. Northern blot analysis demonstrated the presence of one single transcript of approximately 4500 nucleotides. The *slp* gene is expressed at high level up to early stationary phase. However a sharp decrease is observed in a saturated culture, together with a simultaneous drop in rRNA levels due to stringent response (Cashel and Rudd, 1987) (Figure 9). These high levels of expression during most of the bacterial growth cycle are to be expected in view of the continuous need of large amounts of SLP subunits

for the assembly of an intact surface-layer, even at stationary growth phase when the SLP is released into the medium (Howard and Tipper, 1973).

Primer extension assays were performed to study the existence of complex multiple promoters involved in regulation of *slp* gene expression, such as in the case of *B. brevis* 47 (Adachi *et al*, 1989). Using two different primers the 5' end(s) of the transcript were detected. Three different transcription initiation sites were identified in both experiments at positions -184 (P1), -340 (P2) and -385 (P3) with respect to the first nucleotide (+1) of the start codon (Figure 10). Each transcription start site was preceded by a potential -10 and -35 motif as indicated in Figure 10. Spacing between both motifs corresponded to the preferred internal length (16 to 18 bp) for *B. subtilis* promoters (Moran *et al*, 1982).

β -Glucuronidase fusions to study *slp* gene expression. The *slp* promoter was fused to the β -glucuronidase (*uidA*) reporter gene to examine the expression characteristics of this complex 5'-upstream region. Through PCR-mediated site-specific mutagenesis a *NcoI* site was generated at the ATG start codon of the *slp* gene. The promoter was then isolated as a *XbaI/NcoI* fragment and fused to the *uidA* ORF at the *NcoI* site in pSL150, yielding pSL151.

Through the combined action of ExoIII/S1 nuclease a set of progressive deletions towards the ATG start codon was generated and introduced into pSL150 as *XbaI/NcoI* fragments. The exact end point of each deletion was determined by sequence analysis (Figure 11). This set of plasmids (pSL151 to pSL159) was introduced into *B. sphaericus* P-1 by electrotransformation as described in Example 1 and β -glucuronidase activity was monitored.

The results are shown in Figure 11 and can be summarized as follows: deletions up to approximately position -150 are completely abolished in *uidA* expression. Indeed, according to the primer extension assay these mutants are devoid of any of the three identified promoters. Deletions removing sequences up to position -375 show a threefold increase in β -glucuronidase activity as compared to pSL151. These constructs only contain promoter P1. All smaller deletions show again wild-type levels of β -glucuronidase activity. In these mutants all three promoters are intact again.

Effect of Ca^{2+} on *slp* expression. In several cases it has been reported that Ca^{2+} plays a key role in the assembly of the surface-layer on the

bacteria (Feraldo *et al*, 1991 Yang *et al*, 1992). Moreover, Adachi and co-workers (1991) observed that Ca^{2+} repressed the expression of the cell wall protein gene operon of *B. brevis* 47. In this context the previously constructed Pslp-uidA fusions proved to be excellent tools to monitor the possible effect of Ca^{2+} on slp gene expression. Bacteria were grown in LB medium supplemented with an overdose Ca^{2+} (7.5 mM) and compared to cells grown in the absence of Ca^{2+} . β -glucuronidase activity was measured 4 hours after dilution of the cultures (1/100) and simultaneous addition of Ca^{2+} to the medium. As can be seen in Figure 12, addition of Ca^{2+} resulted in a two-fold reduction of β -glucuronidase activity in all mutants up to position -440, whereas mutants containing only promoter P1 were immune to this negative effect. These results suggest that the Ca^{2+} repression is located at promoters P2 and/or P3. These observations were confirmed when assaying enzyme activity 24 hours after addition of Ca^{2+} (data now shown).

Example 3

1. Materials and Methods

Bacterial strains and plasmids. Growth media and selective antibiotic concentrations for *B. sphaericus* P-1 have been described in Example 1. The plasmid pSL64, used as a basis for the construction of the different intermediate vectors, was isolated by insertion of a promoterless nptII gene as a 1.12-kb BamHI/SalI fragment from pKm109/2 (Reiss *et al*, 1984a) into the bifunctional, erythromycin resistance (Em^R) encoding vector pSL40 of Example 1 (Figure 14A). The nucleotide sequence of the linker preceding the nptII gene in pSL64 is shown in Figure 14B1.

A similar plasmid (pSL101) was constructed by exchange of the BamHI/NcoI fragment of pSL64 for a similar sized fragment of pLKM92 to shift the reading frame of the nptII gene, compared to the multicloning site. pLKM92 is pKm109/90 (Reiss *et al*, 1984a) with a slightly modified polylinker. The nucleotide sequence of the linker preceding the nptII gene in pSL101 is shown in Figure 14B2.

pSL4, pSL10, and pSL20 are subclones of the slp gene of Example 2 and are indicated on Figure 15. Intermediate vectors, constructed in the course of this study are summarized in Table IV:

Table IV
Intermediate Vectors

Plasmid Name	Cloned internal part of SLP ^a	Cloning Vector
pSL66	2048-2854	pSL64
pSL68	1470-2476	pSL64
pSL69	443-2053	pSL64
pSL70	443-1609	pSL64
pSL71	49-807	pSL64
pSL102	443-2053	pSL101
pSL111	443-2053	pSL64 ^b
pSL113	2084-2854	pSL101

^a bp 1 is the A base of the start codon; ^b containing the 554-bp Sau3A fragment encoding the central part of S1.

Transformation. Competent *E. coli* MC1061 strains were prepared and transformed according to Kushner (1978), whereas transformation of *B. sphaericus* P-1 was achieved by electroportation as described in Example 1.

Sacculi preparation. Native sacculi were prepared by a protocol described by Sara and Sleytr (1987) and modified for *B. sphaericus* P-1 or derivative strains were grown overnight at 37°C in TB medium (Tartof and Hobbs, 1987) on a gyratory shaker. Cells were harvested by centrifugation, resuspended in 50 mM Tris-HCl, pH 7.2 (50 ml per 100 g pellet), and sonicated for 1 min (40 Watt, using a Bransic Sonic Power Co. sonicator). Triton X-100 was added to a final concentration of 2%, and the mixture was incubated, with agitation, for 30 min at 50°C. Treated cells were collected by centrifugation (15,000 g, 10 min), and washed three times with cold, distilled H₂O. The pellet was resuspended in 5 mM MgCl₂, containing DNase (5 µg/ml) and RNase (20 µg/ml), and incubated for 15 min at 37°C. The resulting native sacculi were pelleted, washed three times with cold distilled H₂O, and resuspended in 20 ml buffer (20 mM Tris-HCl, pH 7.2, 2.5 mM CaCl₂, and 2 mM phenylmethylsulfonylfluoride).

Enzymatic assays. Enzymatic assays were performed either on trichloroacetic acid (TCA)-precipitated culture supernatants or on insoluble and soluble fractions of sonicated cells (4 times 10 sec, 40 W). NPTII activity was assayed by the *in situ* phosphorylation assay after separation of

the proteins on non-denaturing polyacrylamide gels (Reiss *et al*, 1984b). Nicotinamide adenine dinucleotide (NAD) glycohydrolase activity was measured as the release of ¹⁴C-labelled nicotinamide from [carbonyl-¹⁴C]NAD as described by Loch *et al*, (1987).

5 SDS-PAGE and immunoblotting. Sodium dodecyl sulfate polyacrylamide gel electrophoresis and Western blotting were performed by standard procedures (Laemmli, 1979). The filters were blocked with 2% Tween 20 and incubated with an 1:1000 dilution of the specific rabbit (anti-NPTII) or goat (anti-pertussis toxin [PT]) serum, followed by alkaline
10 phosphatase conjugated goat anti-rabbit or mouse anti-goat IgG (Bio-Rad) as described by the manufacturers.

Immunogenicity of recombinant bacteria with composite S-layers in mice. Groups of five female Balb-C mice were injected (intraperitoneally) with different titers of recombinant P-1::pSL111 bacteria (10⁷, 10⁸, and 10⁹
15 colony forming units (CFU)), corresponding to an estimated amount of 0.1, 1, and 10 µg of S1 subunit of pertussis toxin, either with or without Freund's adjuvant. Control experiments included purified S1 subunit of PT, and recombinant P-1::pSL102 bacteria. Injections were repeated after 3 and
20 9 weeks. At week 12, sera samples were collected. Mice sera were screened for the presence of antibodies directed against PT S1 subunit in a sandwich ELISA. PT was used as antigen and captured by a Guinea pig antiserum.

General recombinant DNA techniques. These were according to Sambrook *et al*, (1989). Restriction enzymes were purchased from New
25 England Biolabs, Pharmacia or Bethesda Research Laboratories and were used according to the manufacturers' recommendations. Elution of DNA fragments separated by agarose gel electrophoresis was done using Gene Clean (Trade Mark) kit (Bio101 Inc, La Jolla, California, US). Southern transfer and hybridization were performed using Hybond N⁺ membranes
30 (Amersham) and Quickprime (Trade Mark) labelling kit (Pharmacia) to prepare ³²P-labelled probes.

2. Results

Analysis of carboxy-terminal deletions of *B. sphaericus* P-1 SLP. Sequence analysis of the 4.5-kb *slp* gene of *B. sphaericus* P-1 revealed that
35 the predicted first 200 amino acids of SLP were highly similar to the deduced sequence of the SLP of *B. sphaericus* 2362 (Bowditch *et al*, 1989),

- 43 -

whereas the remaining parts of the proteins were highly divergent. Potential transmembrane helices were predicted to be located near the carboxy-terminal ends of both proteins (Bowditch *et al.*, 1989). Therefore, these conserved motifs might be important in the build-up or anchoring of the S-layer. The fraction of the non-homologous COOH-terminal part of B. sphaericus P-1 SLP that could be removed without notable interference with S-layer assembly was determined by progressive deletions.

Therefore, several intermediate vectors were constructed (based on the bifunctional vector pSL64; Table IV) that contained different internal fragments of the slp gene, cloned upstream of a promoterless nptII gene (pSL66, pSL68, pSL69, pSL70, pSL71; Table IV and Figure 15A). These constructs were introduced into B. sphaericus P-1 by electroporation and selection for Em^R transformants. Neomycin-resistant (Nm^R) colonies, and thus putative single homologous recombinants, were obtained for the P-1 strains transformed by almost all intermediate vectors, except for pSL71 which contained the most amino-terminally located fragment of the slp gene.

Southern analysis revealed the patterns expected for single homologous recombination (see Figure 16 for pSL69 integration). Culture supernatants, insoluble cell debris, and soluble cell contents after sonication of the strains carrying the different carboxy-terminal deletions were analyzed by SDS-PAGE electrophoresis (Figure 15B). Abundant amounts of proteins with the expected molecular masses (see Figure 15A) could be readily observed in the insoluble cell fraction. In contrast with the rather abundant presence of SLP in culture supernatants of wild-type P-1, no such proteins were observed in culture supernatant of strains expressing truncated SLPs, except for P-1::pSL69 (data not shown for P-1::pSL70). These data suggest that, whereas the carboxy-terminal part of the SLP and in particular residues numbered 536 to 1252 in Figure 6 are dispensable, the amino-terminal part and especially residues numbered 31 to 269 in Figure 6 are absolutely required for viability of P-1 cells. Residues numbered 31 to 269 in Figure 6 constitute the N-terminal 239 or 19.56% residues of the mature SLP.

Translational fusion of reporter proteins to the carboxy-terminus of truncated SLPs. To determine whether the deletable part of SLP can be replaced by a protein of interest, we fused reporter proteins NPTII and the soluble fragment of the subunit S1 of toxin produced by Bordetella pertussis (PT) to the carboxy-terminus of truncated SLPs. To achieve this, a similar

- 44 -

strategy as described above was used with the modification that the intermediate vectors now contained an internal slp part, translationally fused to either nptII (pSL102, pSL113; Table IV) or PT in fusion with NPTII (pSL111; Table IV). Figure 17 summarises the expected fusion proteins generated by the different intermediate vectors. Nm^R colonies, putative integrants, were selected after introduction of these intermediate vectors into P-1 by electroporation and selection of Em^R transformants. Southern hybridizations of Bg1II-digested total DNA of these candidates with ³²P-labelled pSL20 (containing a 4-kb Bg1II fragment of the slp gene; Figure 15A), revealed the expected patterns after single homologous recombination through the cloned slp part (Figure 16).

In SDS-PAGE analysis of total protein extracts of recombinant strains P-1::pSL69, P-1::pSL102 and P-1::pSL113 (Figure 18A), major protein bands were observed at 74 kDa, 102 kDa and 130 kDa, respectively, the sizes expected for the truncated SLP or the two different fusion proteins. In total protein extracts of P-1::pSL111 (Figure 18C), however, only a faint protein band of the expected size (120 kDa) could be observed. The fusion SLPs fractionated predominantly to the cell debris after sonication, as was also observed for the truncated SLPs.

Western blottings of similar SDS-PAGE gels were challenged with anti-NPTII or anti-PT antibodies. Anti-NPTII reacted only with the 102-kDa and 130-kDa proteins in P-1::pSL102 and P-1::pSL113 protein extracts, respectively (Figure 18C), whereas in P-1::pSL111 extracts, the 120-kDa protein was revealed (data not shown). No cross-reaction was observed with proteins from P-1::pSL69. Anti-PT detected two specific proteins in P-1::pSL111 (120 kDa and 90 kDa), and four specific low-molecular mass proteins, that were also revealed in P-1::pSL69 extracts (Figure 18D). Signals with both anti-PT and anti-NPTII were significantly enhanced when using proteins from native sacculi preparations (see below).

Reporter proteins fused to SLP retain their enzymatic activity. Because both proteins used as reporters in this study exhibit enzymatic activity that can be relatively quickly assayed, we determined whether the fusion proteins retained these catalytic abilities.

Kanamycin phosphorylation activity of fusion proteins was determined by the in gel assay, using either TCA-precipitated culture supernatants, or cell debris and soluble fraction after sonication. Significant phosphorylation

activity was observed in all recombinant strains (but not in P-1 or in P-1::pSL69 extracts) and was confined almost exclusively to the insoluble cell debris fraction after sonication (Figure 19).

5 NAD-glycohydrolase activity, specified by the S1 subunit of the B. pertussis toxin, was determined on TCA-precipitated culture supernatant, or cell debris and soluble fraction after sonication of the recombinant strain P-1::pSL111 (Table V), in comparison to a calibration curve using purified PT toxin. Again, significant enzymatic activities were only detected in cellular debris fraction of P-1::pSL111. The apparently high, a specific
10 hydrolase activity detected in the supernatant of both P-1::pSL111 and P-1::pSL69 is due to acid hydrolysis caused by TCA residues from the precipitation (data now shown).

Table V

NAD-glycohydrolase activities of recombinant P-1 strains

Protein Source	Released C14-nicotinamide (cmp)
PT toxin ($\mu\text{g/ml}$)	
0	1860
1	5350
5	10520
10	14810
20	21850
40	26050
P-1::pSL69	
cell debris	1340
sonicate	1480
P-1::pSL111	
cell debris	5380
sonicate	1530

15 Carboxy-terminal fusions to SLP assemble in a functional S-layer. To address the question whether fusion proteins between truncated SLP and NPTII assemble into a S-layer, intact bacteria were immunogold-labelled using anti-NPTII antibodies. Significant accumulation of label on the

bacteria was observed with P-1::pSL102 and to a lesser extent with P-1::pSL113 (Figures 20A and 20B). No background label could be found using either P-1 or P-1::pSL69 (which contains an intracellular NPTII protein).

5 Circumstantial evidence for the assembly of the fusion proteins into an S-layer, comes from the preparation of ghost cells, or native sacculi as described by Sara and Sleytr (1987), in which cytoplasm and membrane are removed without affecting the structural integrity of the peptide-glycan layer and the S-layer. Application of this protocol to recombinant P-1::pSL102,
10 and P-1::pSL111 strains resulted in sacculi preparations, significantly enriched in fusion S-layer protein (Figure 21A). Western blots, challenged with anti-NPTII or anti-PT detected readily the fusion proteins (Figures 21B and 21C).

 The immunogenicity of the composite S-layers was determined by
15 injection of the recombinant bacteria P-1::pSL111, expressing the S1 subunit of PT fused to SLP, along with purified S1 and recombinant P-1::pSL102 bacteria as controls. S1 antibody titers were determined after 12 weeks by ELISA (Table VI). A significant higher amount of S1-recognizing antibodies were detected in blood samples of the groups of mice
20 injected by the highest concentration of the recombinant bacteria expressing the S1-subunit in a composite S-layer (P-1::pSL111).

Table VI
Immunogenicity of recombinant P-1::pSL111 in Balb/c mice

	Antigen (μg)	Dilution 1:20	Dilution 1:80
S1	0.1	19.7	14.9
	1	426.1	402.1
	10	465.5	460.8
S1 + AF	0.1	132.5	56.0
	1	418.2	432.4
	10	457.8	453.7
IB111	0.1	49.5	2.2
	1	39.8	1.9
	10	238.7	116.8
IB111 + AF	0.1	160.9	75.7
	1	158.8	70.3
	10	354.3	210.8
IB102	0.1	34.5	3.8
	1	43.9	1.7
	10	67.6	6.5
IB102 + AF	0.1	117.0	16.8
	1	151.1	57.4
	10	160.1	65.2

Values are geometric means of ELISA titer readings of five independent injections. AF, Freund's adjuvant; IB111, intact bacteria P-1::pSL111; IB102, intact bacteria P-1::pSL102.

Table VII

5

**Detailed information on the construction of intermediate
vectors for the construction of truncated SLP's and
composite SLP's.**

Note on numbering: base 1 = A of ATG of the *slp* gene
(= mRNA numbering + 95)

Simple SLP clones

- pSL4 = 1536 bp HindIII fragment in pUC18 HindIII. This fragment contains the complete slp promoter and slp gene portion 1 to 142.
- 5 pSL5 = slp gene portion 49-807 (PvuII-PvuII) in pUC18 SmaI.
- pSL10 = slp gene portion 443-2053 (BglII-BglII) in pUC18 BamHI.
- pSL20 = 3048 bp HindIII fragment in pUC18 HindIII. This fragment contains the slp gene portion 1049 to end of ORF (3759) and the transcription termination signal.

Truncated SLP intermediate vectors

Name	Cloned <u>slp</u> part	Restriction site and clone	Site in pSL64
pSL66	2048-2854	pSL20 BglII	BamHI
pSL68	1470-2476	pSL20 PvuII	EcoRV
pSL69	443-2053	pSL10 XbaI/EcoRI	XbaI/EcoRI
pSL70	443-1609	pSL10 XbaI/HpaI	XbaI/EcoRV
pSL71	49-807	pSL5 XbaI/EcoRI	XbaI/EcoRI

10 Composite SLP intermediate vectors

- pSL109: 554 bp Sau3A fragment cloned in BamHI site of pSL64 and selection of the correct orientation.
- pSL102: EcoRI-BglIII fragment of pSL20 (1049-2053) in BamHI site of pSL101.
- 15 pSL113: BglII fragment of pSL20 (2048-2854) in BamHI site of pSL101.
- pSL111: Same as pSL102 in BamHI site of pSL109.
- pSL40 = 7453 bp high copy number bifunctional vector, Example 1 and Figure 4A.
- pSL84 = 6679 bp low-copy number bifunctional vector, Example 1 and Figure 4B.
- 20 pSL150 = promoterless β -glucuronidase gene isolated as 2558 bp BamHI/SphI fragment and cloned in pSL40 BamHI/SphI, Example 2.
- 25 pSL151-159 = XbaI/NcoI fragments carrying progressive deletions of the slp promoter into pSL150

- 49 -

XbaI/NcoI. Exact end points of the deletions are indicated in Example 2 and Figure 10. NcoI site coincides with ATG start codon.

5 pSL64 = 1.12 kb BamHI/SalI fragment, carrying promoterless nptII gene from pKm109/2 into pSL40 BamHI/SalI, Example 3 and Figure 14A.

pSL101 = essentially the same as pSL64, but having another DNA linker in front of the nptII gene, Example 3 and Figure 14B.

References

- 10 Adachi et al (1989) J. Bacteriol. 171, 1010-1016.
Adachi et al (1991) J. Bacteriol. 176, 4243-4245.
Aiba et al (1981) J. Biol. Chem. 256, 11905-11910.
Bauw et al (1987) Proc. Natl. Acad. Sci. USA 84, 4806-4810.
Bone and Ellar (1989) FEMS Microbiol. Lett. 58, 171-178.
15 Botterman and Zabeau (1987) DNA 6, 583-591.
Bowditch et al (1989) J. Bacteriol. 171, 4178-4188.
Brutlag et al (1990) Comp. Appl. Biol. Sci. 6, 237-245.
Casadaban and Cohen (1980) J. Mol. Biol. 138, 179-207.
Cashel and Rudd (1987) In *Escherichia coli and Salmonella typhimurium*,
20 Cellular and Molecular Biology, F.C. Neidhardt, J.L. Ingraham, K.B. Low,
B. Magasanik, M. Schaechter, and H.E. Umbarger (Eds.). Washington,
American Society for Microbiology, pp. 1410-1438.
Chang and Cohen (1978) J. Bacteriol. 134, 1141-1156.
Charles and Dougan (1990) Trends Biotechnol. 8, 117-121.
25 Chassy et al (1988) Trends Biotechnol. 6, 303-309.
Clewell et al (1974) J. Bacteriol. 117, 283-289.
Desomer et al (1990) Appl. Environm. Microbiol. 56, 2818-2825.
Faraldo et al (1991) J. Bacteriol. 173, 5346-5351.
Gasson and Davies (1980) FEMS Microbiol. Lett. 7, 51-53.
30 Georgiou et al (1993) Tibtech 11, 6-10.
González et al (1981) Plasmid 5, 351-365.
Gruss and Ehrlich (1989) Microbiol. Rev. 53, 231-241.
Hager and Rabinowitz (1985). In *The Molecular Biology of Bacillus subtilis*,
Vol II. D.A. Dubnau (Ed.) Orlando, Academic Press, 1-32.
35 Hanahan (1983) J. Mol. Biol. 166, 557-580.
Howard and Tipper (1973) J. Bacteriol. 113 (3) 1491-1504.

- Jefferson et al (1986) *Proc. Natl. Acad. Sci. USA* 83, 8447-8451.
- Johnston and Richmond (1970) *J. Gen. Microbiol.* 60, 137-139.
- König (1988) *Can. J. Microbiol.* 34, 395-406.
- Kushner (1978). In *Genetic engineering*, Boyer and Nicosia (eds.),
5 Amsterdam:Elsevier/North-Holland Biochemical Press, pp. 17-23.
- Kyte and Doolittle (1982) *J. Mol. Biol.* 157, 105-132.
- Laemmli (1970) *Nature (London)* 227, 680-685.
- Lepault et al (1986) *J. Bacteriol* 168, 303-308.
- Lewis et al (1987) *J. Bacteriol.* 169, 72-79.
- 10 Locht et al (1987) *Infection and Immunity* 55, 2546-2553.
- Lupas et al (1994) *J. Bacteriol.* 176, 1224-1233
- Mielenz (1983) *Proc. Natl. Acad. Sci. USA* 80, 5975-5979.
- Miller (1972) *Experiments in Molecular genetics*. New York, Cold Spring
Harbor Laboratory.
- 15 Matuschek et al (1994) *J. Bacteriol.* 176, 3295-3302
- Mongkolsuk et al (1983) *J. Bacteriol.* 155, 1399-1406.
- Moran et al (1982) *Mol. Gen. Genet.* 186, 339-346.
- Orzech and Burke (1984) *FEMS Microbiol. Lett.* 25, 91-95.
- Peleman et al (1989) *Plant Cell* 1, 81-93.
- 20 Platt (1986) *Ann. Rev. Biochem.* 55, 339-372.
- Rao and Argos (1986) *Biochem. Biophys. Acta* 869, 197-214.
- Reiss et al (1984a) *EMBO J.* 3, 3317-3322.
- Reiss et al (1984b) *Gene* 30, 211-218.
- Sambrook et al (1989), *Molecular cloning, a laboratory manual*. Cold
25 Spring Harbor, Cold Spring Harbor Laboratory Press.
- Sanger et al (1977) *Proc. Natl. Acad. Sci. USA* 74, 5463-5467.
- Sára and Sleytr (1987) *J. Bacteriol.* 169, 4092-4098.
- Simon and Chopin (1988) *Biochimie* 70, 559-566.
- Sleytr and Messner (1988) *J. Bacteriol.* 170, 2891-2897.
- 30 Smith et al (1993) *Vaccine* 11, 919-924.
- Sonstein and Baldwin (1972) *J. Bacteriol.* 109, 262-265.
- Swinfield et al (1990) *Gene* 87, 79-90.
- Tagaki et al (1989) *Agric. Biol. Chem.* 53, 3099-3100.
- Takao et al (1989) *Appl. Micro and Biotech.*, Spring 1989, 30, 75-80.
- 35 Tang et al (1989) *J. Bacteriol.* 171, 12, 6637-6648.
- Tartof and Hobbs (1987) *Focus* 9, 12.

- Taylor and Burke (1990) FEMS Microbiol. Lett. 66, 125-128.
- Tsuboi et al (1988) J. Bacteriol. 170, 935-945.
- Tsuboi et al (1989) J. Bacteriol 171, 12, 6747-6752.
- Tsukagoshi et al (1985) J. Bacteriol. 164, 3, 1182-1187.
- 5 Tsukagoshi (1987/8) (Crystalline Bacterial Cell Surface Layers, (EMBO Workshop, Vienna, Austria, Aug. 31-Sept. 2, 1987) Springer-Verlag, Sleytr, U.B., et al., ed., 1988, 145-148).
- Vieira and Messing (1982) Gene 19, 259-268.
- von Heijne (1986) Nucl. Acids Res. 14, 4683-4690.
- 10 Watson et al (1987) Molecular Biology of the Gene, 4th edition, The Benjamin/Cummings Publishing Company Inc.
- Yamagata et al (1987) J. Bacteriol. 169, 3, 1239-1245.
- Yamagata et al (1989) Proc. Natl. Acad. Sci. USA 86, 3589-3593
- Yang et al (1992) J. Bacteriol. 174, 1258-1267.
- 15 Yanisch-Perron et al (1985) Gene 33, 103-119.

INDICATIONS RELATIVES A UN MICRO-ORGANISME DEPOSE

(règle 13bis du PCT)

A. Les indications ont trait au micro-organisme visé dans la description page <u>12</u> , ligneS <u>21-26</u>	
B. IDENTIFICATION DU DEPOT D'autres dépôts font l'objet d'une feuille supplémentaire <input type="checkbox"/>	
Nom de l'institution de dépôt BELGIAN COORDINATED COLLECTIONS OF MICROORGANISMS (BCCM)	
Adresse de l'institution de dépôt (y compris le code postal et le pays) Universiteit Gent Laboratorium voor Moleculaire Biologie K.L. Ledeganckstraat, 35 B-9000 GENT (Belgique)	
Date du dépôt 13 mai 1993	n° d'ordre LMG P-13855
C. INDICATIONS SUPPLEMENTAIRES (le cas échéant) Une feuille supplémentaire est jointe pour la suite de ces renseignements <input type="checkbox"/>	
Bacillus sphaericus P-1	
D. ETATS DESIGNES POUR LESQUELS LES INDICATIONS SONT DONNEES (si les indications ne sont pas données pour tous les Etats désignés)	
E. INDICATIONS FOURNIES SEPAREMENT (le cas échéant) Les indications énumérées ci-après seront fournies ultérieurement au Bureau international (spécifier la nature générale des indications p. ex., "n° d'ordre du dépôt")	

Réservé à l'office récepteur
<input checked="" type="checkbox"/> Cette feuille a été reçue en même temps que la demande internationale
Fonctionnaire autorisé  C.A.J.A. PASCHE

Réservé au Bureau international
<input type="checkbox"/> Cette feuille est parvenue au Bureau international le :
Fonctionnaire autorisé

C L A I M S

1 - A host cell which is provided with a S-layer comprising a fusion polypeptide consisting essentially of :

- 5 (a) at least sufficient of a S-layer protein for a S-layer composed thereof to assemble, and
(b) a heterologous polypeptide which is fused to either the carboxy terminus of (a) or the amino terminus of (a) and which is thereby presented on the outer surface of the said cell.

10 2 - A cell according to claim 1 which is a bacterium of the genus Bacillus.

3 - A cell according to claim 2 wherein the bacterium is B. sphaericus P-1 (LMG P-13855).

15 4 - A cell according to any one of the preceding claims, wherein the heterologous polypeptide is fused to either the carboxy terminus or the amino terminus of the most N-terminal 41 % or more amino acid residues of a S-layer protein.

5 - A cell according to any one of the preceding claims, wherein the S-layer protein is derived from B. sphaericus.

20 6 - A cell according to any one of the preceding claims, wherein the heterologous polypeptide is an antigenic peptide.

7 - A cell according to claim 6, wherein the heterologous polypeptide comprises an antigenic determinant of a pathogen selected from a virus, bacterium, fungus, yeast and parasite.

25 8 - A cell according to claim 6, wherein the heterologous polypeptide is selected from the P69 antigen of Bordetella pertussis, pertussis toxin or a subunit thereof, tetanus toxin fragment C, E. coli heat labile toxin B subunit and an E. coli K88 antigen.

9 - Sacculi derived from a host cell as claimed in any one of the preceding claims.

10 - A pharmaceutical or veterinary composition comprising a host cell as claimed in any one of claims 1 to 8 or sacculi as claimed in claim 9 and a pharmaceutically or veterinarily acceptable carrier or diluent.

5 11 - A vaccine comprising a host cell as claimed in any one of claims 6 to 8 or sacculi as claimed in claim 9 when dependent on any one of claims 6 to 8 and an acceptable carrier or diluent therefor.

10 12 - A recombinant DNA molecule which comprises a promoter operably linked to a coding sequence which encodes a signal peptide and a fusion polypeptide, the signal peptide being capable of directing the said fusion polypeptide to be presented on the surface of a host cell in which expression occurs and the fusion polypeptide consisting essentially of a heterologous polypeptide fused to either the carboxy terminus or the amino terminus of at least sufficient of a S-layer protein for a S-layer composed thereof to assemble.

15 13 - A molecule according to claim 12, wherein the promoter is a promoter for a S-layer protein from a Bacillus bacterium.

14 - A molecule according to claim 13, wherein the promoter is the P1 promoter of B. sphaericus P-1 (LMG P-13855).

20 15 - A molecule according to any one of claims 12 to 14, wherein the signal peptide is the signal peptide for the S-layer protein of which an appropriate portion is incorporated in the fusion polypeptide.

16 - A molecule according to any one of claims 12 to 15, wherein the signal peptide is a signal peptide for a S-layer protein of a Bacillus bacterium.

25 17 - A molecule according to any one of claims 12 to 16 which is an expression vector.

18 - A molecule according to claim 17, wherein the vector is a plasmid.

19 - A host cell which incorporates a recombinant DNA molecule as claimed in any one of claims 12 to 16.

20 - A host cell according to claim 19 which has been transformed with a vector as claimed in claim 17 or 18.

21 - A cell according to claim 19 or 20 which is a gram-positive bacterium.

5 22 - A cell according to claim 19 or 20 which is a bacterium of the genus Bacillus.

23 - A cell according to claim 22 wherein the bacterium is B. sphaericus P-1 (LMG P-13855).

10 24 - A process for the preparation of a host cell provided with a S-layer comprising a fusion polypeptide, which process comprises:

- 15 (i) providing a suitable host cell incorporating a recombinant DNA molecule which comprises a promoter operably linked to a coding sequence which encodes a signal peptide and a fusion polypeptide, the signal peptide being capable of directing the said fusion polypeptide to be presented on the surface of the said host cell and the fusion polypeptide consisting essentially of a heterologous polypeptide fused to either the carboxy terminus or the amino terminus of at least sufficient of a S-layer protein for a S-layer composed thereof to assemble; and
- 20 (ii) culturing the said host cell so that the said fusion polypeptide is expressed and a S-layer comprising the fusion polypeptide is formed on the surface of the said host cell, the heterologous polypeptide thereby being presented on the outer surface of the said host cell.

25 - A process according to claim 24, which comprises :

- 25 (a) providing an intermediate vector in which the coding sequence of an internal portion of the native S-layer protein of the said host cell has translationally fused to the 3'-end thereof the coding sequence for the heterologous polypeptide and in which the said coding sequences are provided upstream of a promoterless selectable marker gene such that they form a translational or transcriptional fusion therewith;
- 30 (b) transforming the said host cell with the intermediate vector;
- (c) selecting a transformed host cell which has a S-layer comprising the said fusion polypeptide.

26 - A process according to claim 24 which comprises :

- 5 (a) fusing to a promoter a S-layer protein coding sequence coding for the signal peptide and at least sufficient of the amino-terminal portion of a S-layer protein for a S-layer composed thereof to assemble on the surface of the host cell, and fusing a peptide coding sequence coding for the heterologous polypeptide to the 3'-end of the S-layer protein coding sequence, whereby a recombinant DNA molecule for the expression and presentation of the fusion polypeptide is prepared;
- 10 (b) inserting the recombinant DNA molecule into a suitable vector, whereby a recombinant DNA vector is prepared;
- (c) transforming a suitable host cell with the recombinant DNA vector, whereby a transformed host cell having the recombinant DNA molecule is provided;
- 15 (d) culturing the transformed host cell, whereby the fusion polypeptide is expressed and a S-layer comprising the fusion polypeptide is assembled on the host cell wall.

27 - A promoter having a -35 region of the sequence TTGAAT and a -10 region of the sequence TATATT.

28 - A promoter according to claim 27, having the sequence
20 CTAAATTTATGTCCCAATGCTTGAATTTTCGGAAAAGATAGTGTTAT
ATTATTGT.

29 - A promoter having a -35 region of the sequence CTTGGTT and a -10 region of the sequence TATAAT.

30 - A promoter according to claim 29, having the sequence
25 TCCAGAAAATGCTTGGTTATTATTGAGAGTAAGGTATAATAGGTA.

31 - A promoter having a -35 region of the sequence ATTACGGGA and a -10 region of the sequence TTTAGT.

32 - A promoter according to claim 31, having the sequence
AAAATATTACGGGAGTCTTTAATTTTTGACAATTTAGTAACCAT.

30 33 - A promoter according to any one of claims 27 to 32, having the sequence from nucleotide 52 to 353 shown in Figure 10.

34 - An expression vector which comprises a promoter as defined in any one of claims 27 to 33 and a downstream cloning site into which a DNA sequence encoding a heterologous protein may be cloned such that the promoter is operably linked to the said sequence.

5 35 - An expression vector which comprises a promoter as defined in any one of claims 27 to 33 operably linked to a DNA sequence encoding a heterologous protein.

10 36 - A DNA fragment comprising a promoter according to any one of claims 27 to 33 operably linked to a DNA sequence encoding a heterologous protein.

37 - A host cell transformed with an expression vector as defined in claim 35.

15 38 - A process for the preparation of a heterologous protein, which process comprises culturing a transformed host cell according to claim 37 and obtaining the heterologous protein thus expressed.

39 - A pharmaceutical or veterinary composition comprising a pharmaceutically or veterinarily acceptable carrier or diluent and, as active ingredient, a physiologically active heterologous protein which has been obtained by the process of claim 38.

20 40 - A process of transforming B. sphaericus P-1 cells with DNA, which process comprises harvesting B. sphaericus P-1 cells at the late stationary growth phase, mixing the harvested cells with the DNA and effecting electroporation to cause entry of the DNA into the said cells.

25 41 - Use of a host cell as claimed in any one of claims 1 to 8 for immobilisation purposes.

42 - Use of a host cell as claimed in any one of claims 1 to 8 for screening purposes.

FIG. 1A

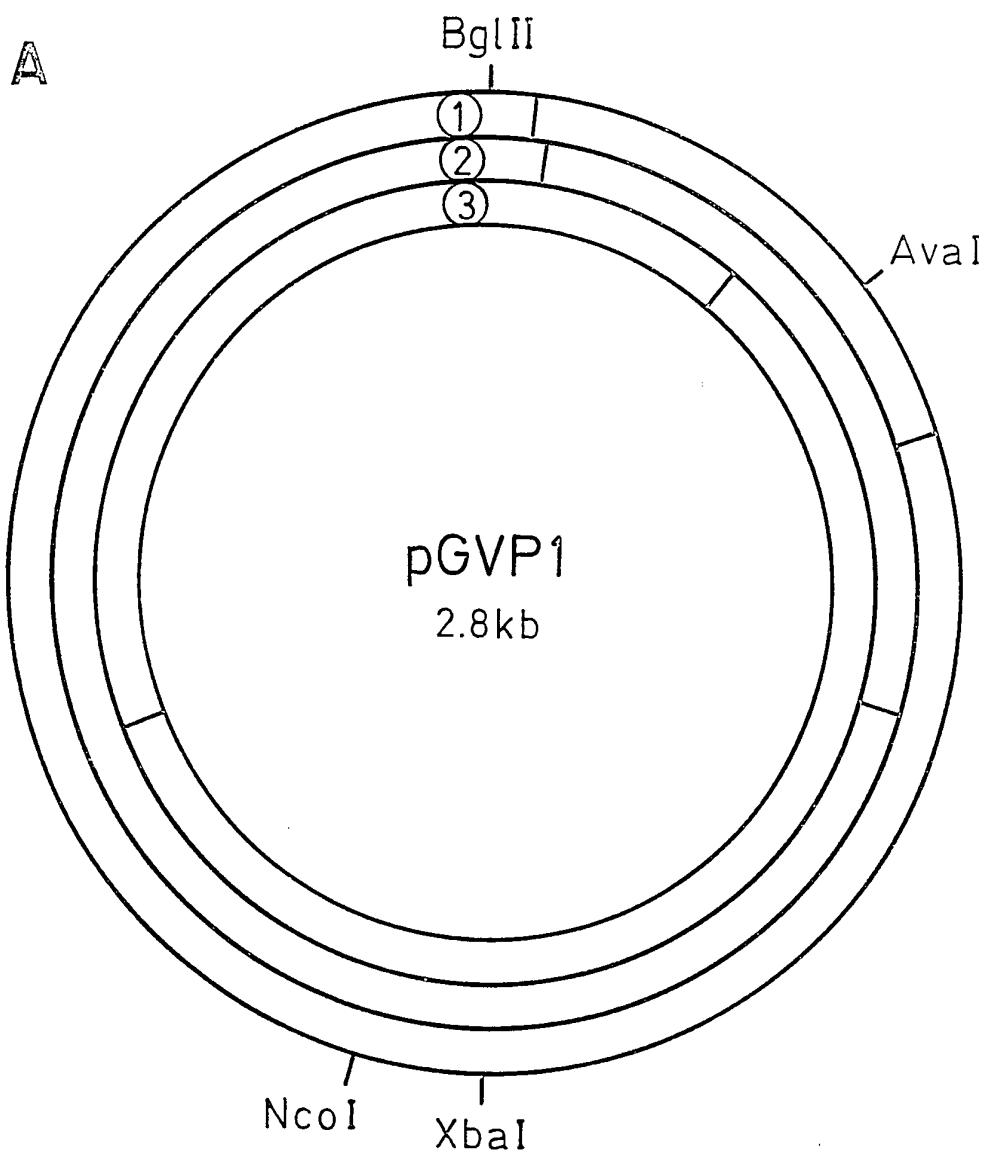

FIG. 1B

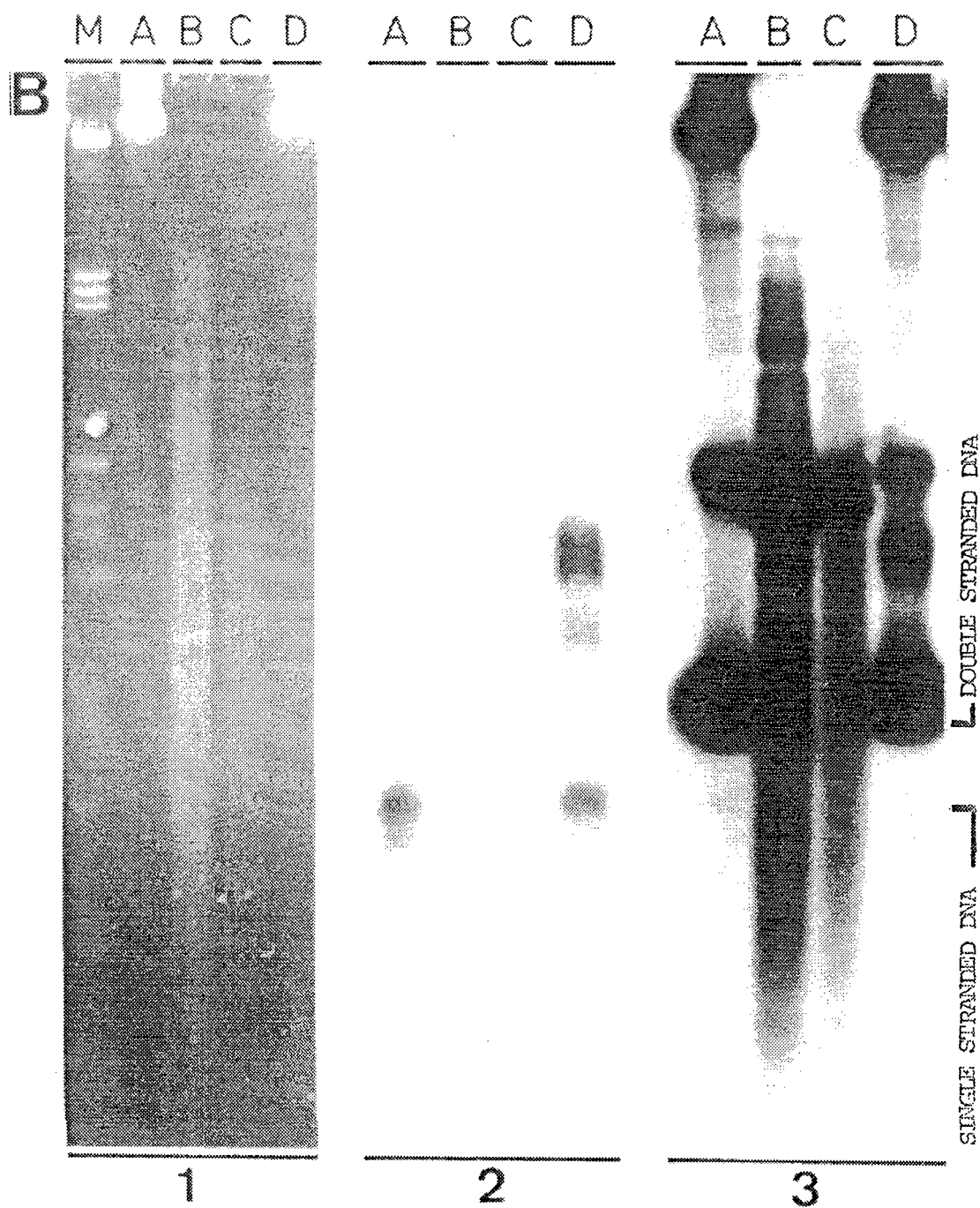
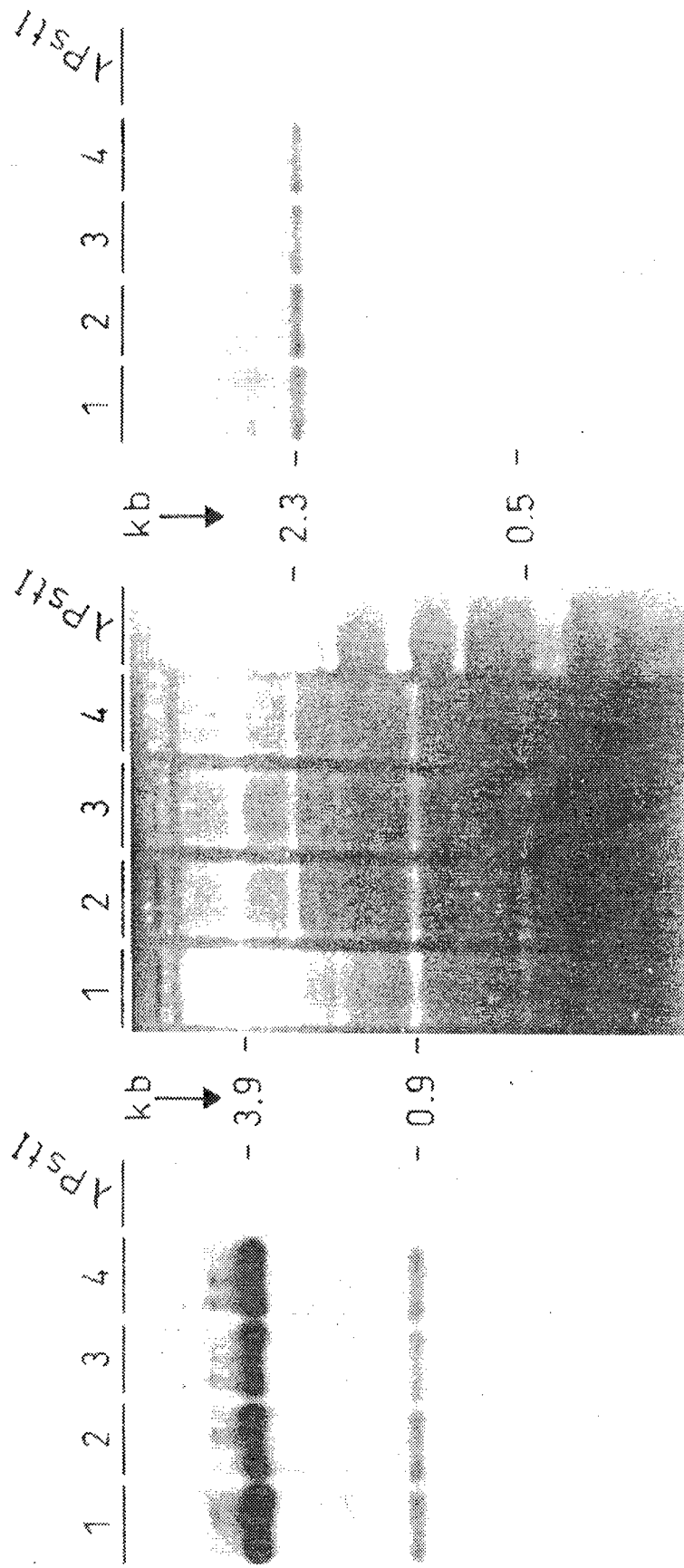

FIG. 2



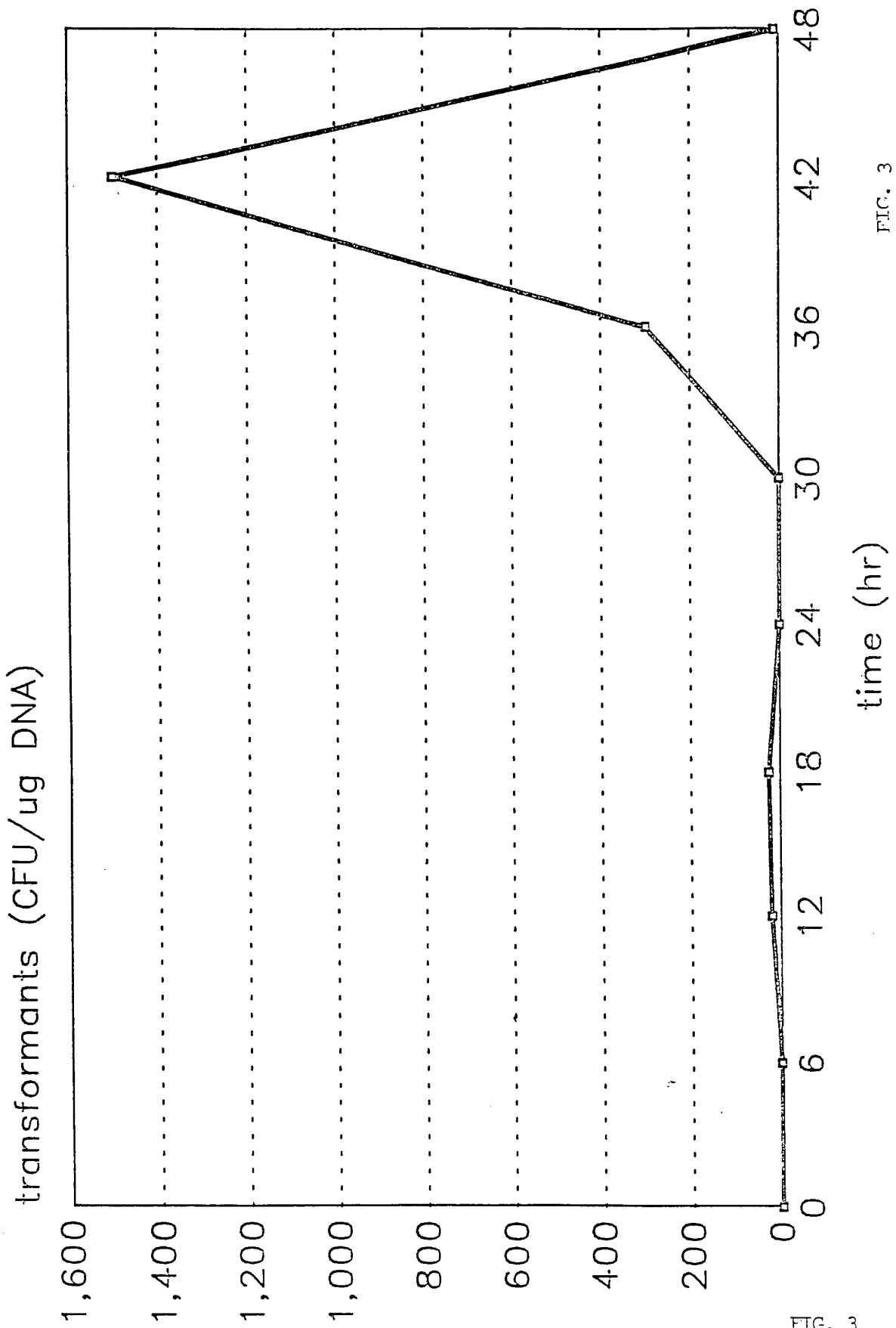

FIG. 3

FIG. 3

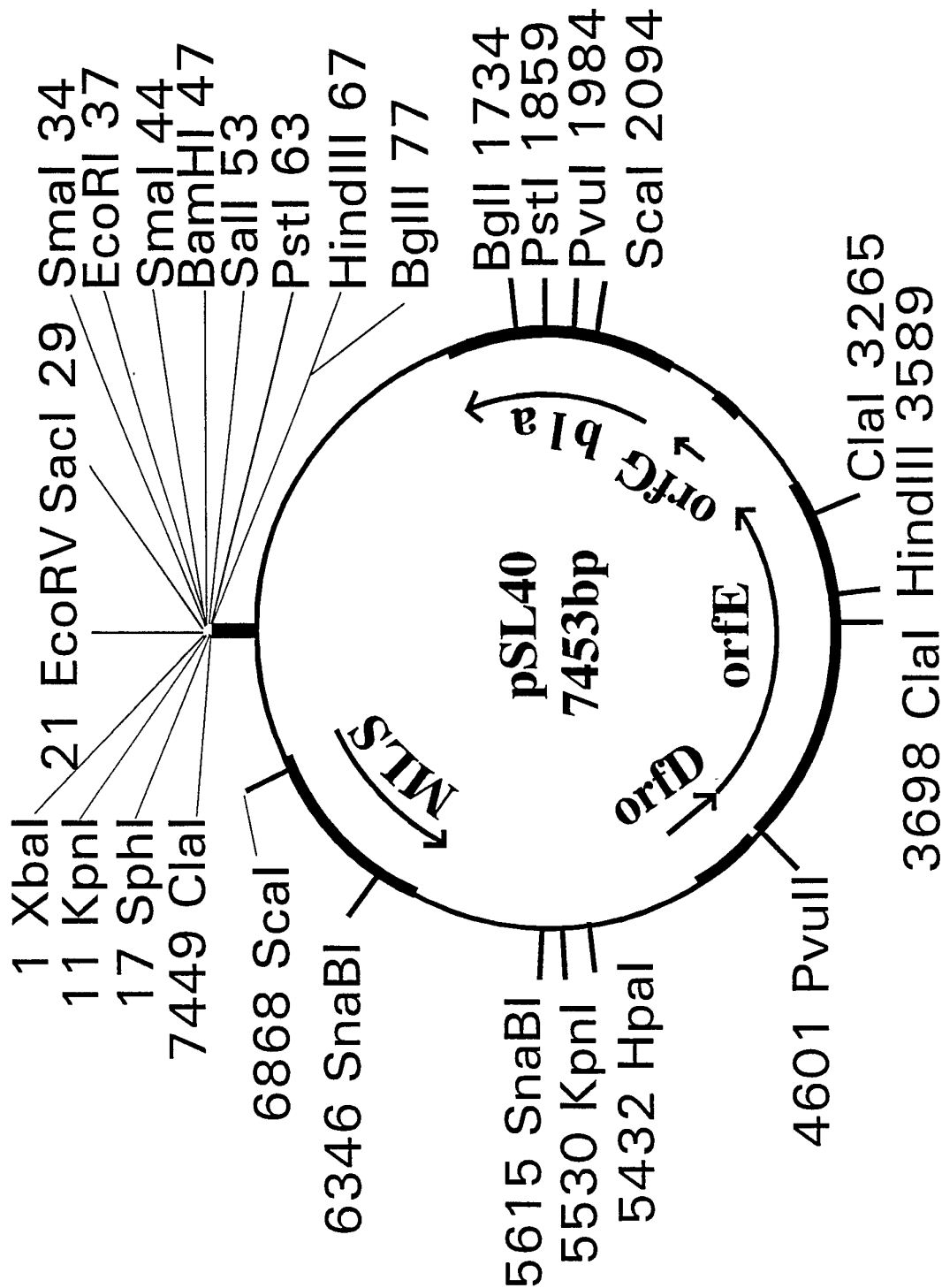
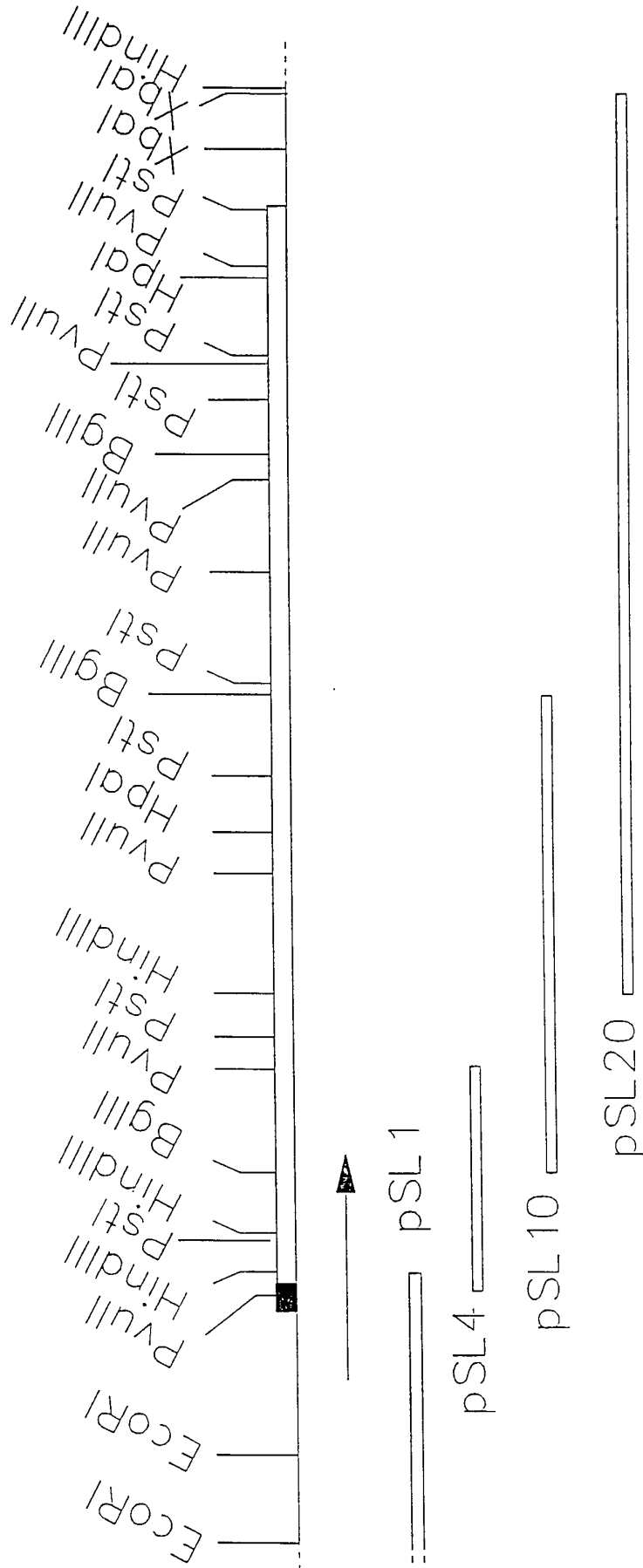

FIG. 4A



200bp
FIG.5

FIGURE 6 (Fig. 6a-6i)

FIGURE 6a

GAAAGCTATA ATACATACAT TTAGGTAAC T AGGCGGTACT ATAGTTTTTCG TTGGATTAAT

ATCAATTTAA GGAATTTTAG GGAGGAAATAC ATTA ATG GCA AAG CAA AAC AAA

Met Ala Lys Gln Asn Lys

GGC CGT AAG TTC TTC GCG GCA TCA GCA ACA GCT GCA TTA GTT GCA TCG

Gly Arg Lys Phe Phe Ala Ala Ser Ala Thr Ala Ala Leu Val Ala Ser

GCA ATC GTA CCT GTA GCA TCT GCT GCA CAA GTA AAC GAC TAT AAC AAA

Ala Ile Val Pro Val Ala Ser Ala Ala Gln Val Asn Asp Tyr Asn Lys

ATC TCT GGA TAC GCT AAA GAA GCA GTT CAA GCT TTA GTT GAC CAA GGC

Ile Ser Gly Tyr Ala Lys Glu Ala Val Gln Ala Leu Val Asp Gln Gly

GTA ATC CAA GGT GAT ACT AAC GGG AAC TTC AAC CCA CTT AAC ACA GTA

Val Ile Gln Gly Asp Thr Asn Gly Asn Phe Asn Pro Leu Asn Thr Val

ACT CGT GCA CAA GCT GCA GAA ATC TTC ACA AAA GCT TTA GAA TTA GAA

Thr Arg Ala Gln Ala Ala Glu Ile Phe Thr Lys Ala Leu Glu Leu Glu

GCT AAC GGA GAT GTA AAC TTC AAA GAC GTG AAA GCT GGC GCT TGG TAC

Ala Asn Gly Asp Val Asn Phe Lys Asp Val Lys Ala Gly Ala Trp Tyr

TAC AAC TCA ATC GCT GCT GTT GTA GCT AAC GGC ATT TTT GAA GGT GTT

Tyr Asn Ser Ile Ala Ala Val Val Ala Asn Gly Ile Phe Glu Gly Val

AGT GCA ACT GAA TTT GCA CCA AAC AAA TCT TTA ACT CGT TCT GAA GCT

Ser Ala Thr Glu Phe Ala Pro Asn Lys Ser Leu Thr Arg Ser Glu Ala

FIGURE 6b

GCT AAA ATT TTA GTA GAA GCA TTC GGT TTA GAA GGT GAA GCA GAT CTT
Ala Lys Ile Leu Val Glu Ala Phe Gly Leu Glu Gly Glu Ala Asp Leu

AGC GAA TTT GCT GAC GCT TCT CAA GTA AAA CCT TGG GCT AAA AAA TAC
Ser Glu Phe Ala Asp Ala Ser Gln Val Lys Pro Trp Ala Lys Lys Tyr

TTA GAA ATC GCA GTA GCT AAC GGC ATT TTC GAA GGT ACT GAT GCA AAC
Leu Glu Ile Ala Val Ala Asn Gly Ile Phe Glu Gly Thr Asp Ala Asn

AAA CTT AAC CCT AAC AAC TCA ATC ACT CGT CAA GAC TTT GCA CTA GTG
Lys Leu Asn Pro Asn Asn Ser Ile Thr Arg Gln Asp Phe Ala Leu Val

TTC AAA CGT ACA GTT GAC AAA GTT GAA GGT GAA ACT CCA GAA GAA GCA
Phe Lys Arg Thr Val Asp Lys Val Glu Gly Glu Thr Pro Glu Glu Ala

GCA TTT GTT AAA GCT ATC AAC AAC ACA ACT GTT GAA GTA ACA TTC GAA
Ala Phe Val Lys Ala Ile Asn Asn Thr Thr Val Glu Val Thr Phe Glu

GAA GAA GTT ACT AAC GTT CAA GCA CTT AAC TTC AAA ATC GAA GGT TTA
Glu Glu Val Thr Asn Val Gln Ala Leu Asn Phe Lys Ile Glu Gly Leu

GAA ATT AAA AAT GCT TCT GTT AAA CAA ACA AAC AAA AAA GTT GTT GTA
Glu Ile Lys Asn Ala Ser Val Lys Gln Thr Asn Lys Lys Val Val Val

TTA ACT ACT GAA GCT CAA ACA GCT GAT AAA GAG TAT GTT TTA ACT CTT
Leu Thr Thr Glu Ala Gln Thr Ala Asp Lys Glu Tyr Val Leu Thr Leu

GAC GGC GAA ACA ATC GGT GGC TTT AAA GGT GTG GCT GCT GTA GTT CCA
Asp Gly Glu Thr Ile Gly Gly Phe Lys Gly Val Ala Ala Val Val Pro

ACT AAA GTT GAA CTA GTA TCT TCT GCA GTT CAA GGT AAA CTT GGT CAA
Thr Lys Val Glu Leu Val Ser Ser Ala Val Gln Gly Lys Leu Gly Gln

GAA GTA AAA GTT CAA GCT AAA GTA ACT GTT GCT GAA GGT CAA TCT AAA
Glu Val Lys Val Gln Ala Lys Val Thr Val Ala Glu Gly Gln Ser Lys

GCT GGT ATT CCT GTT ACT TTC ACT GTA CCA GGT AAC AAC AAT GAT GGC
Ala Gly Ile Pro Val Thr Phe Thr Val Pro Gly Asn Asn Asn Asp Gly

GTT GTA CCA ACA TTA ACA GGT GAA GCT TTA ACA AAC GAA GAG GGT ATC
Val Val Pro Thr Leu Thr Gly Glu Ala Leu Thr Asn Glu Glu Gly Ile

GCA ACA TAC TCT TAC ACT CGT TAT AAA GAA GGT ACT GAT GAA GTA ACT
Ala Thr Tyr Ser Tyr Thr Arg Tyr Lys Glu Gly Thr Asp Glu Val Thr

GCT TAT GCA ACT GGT GAT CGT TCT AAA TTC TCA CTT GGT TAT GTA TTC
Ala Tyr Ala Thr Gly Asp Arg Ser Lys Phe Ser Leu Gly Tyr Val Phe

TGG GGT GTA GAT ACA ATT CTT TCA GTT GAA GAA GTA ACT ACA GGT GCT
Trp Gly Val Asp Thr Ile Leu Ser Val Glu Glu Val Thr Thr Gly Ala

TCA GTT AAT AAT GGT GCA AAC AAA ACT TAC AAA GTT ACT TAT AAA AAC
Ser Val Asn Asn Gly Ala Asn Lys Thr Tyr Lys Val Thr Tyr Lys Asn

CCT AAA ACT GGT AAA CCA GAA GCA AAC AAA ACA TTT AAT GTT GGT TTT
Pro Lys Thr Gly Lys Pro Glu Ala Asn Lys Thr Phe Asn Val Gly Phe

GTA GAA AAC ATG AAT GTT ACT TCT GAT AAA GTA GCA AAT GCT ACA GTT
Val Glu Asn Met Asn Val Thr Ser Asp Lys Val Ala Asn Ala Thr Val

AAT GGC GTA AAA GCA TTA CAA TTA AGC AAT GGT ACA GCT TTA GAC GCT
Asn Gly Val Lys Ala Leu Gln Leu Ser Asn Gly Thr Ala Leu Asp Ala

GCT CAA ATT ACA ACA GAT TCT AAA GGT GAA GCT ACA TTC ACA GTT TCT
Ala Gln Ile Thr Thr Asp Ser Lys Gly Glu Ala Thr Phe Thr Val Ser

GGT ACT AAT GCA GCT GTA ACG CCA GTA GTA TAT GAT CTA CAC AGC ACT
Gly Thr Asn Ala Ala Val Thr Pro Val Val Tyr Asp Leu His Ser Thr

AAC AAT AGT ACT TCA AAT AAA AAA TAT AGT GCA TCT GCT TTA CAA ACT
Asn Asn Ser Thr Ser Asn Lys Lys Tyr Ser Ala Ser Ala Leu Gln Thr

ACT GCT TCT AAA GTA ACT TTC GCT GCT CTT CAA GCA GAG TAT ACA ATT
Thr Ala Ser Lys Val Thr Phe Ala Ala Leu Gln Ala Glu Tyr Thr Ile

GAG TTA ACT CGT GCT GAT AAT GCT GGA GAA GTT GCT GCA ATT GGC GCT
Glu Leu Thr Arg Ala Asp Asn Ala Gly Glu Val Ala Ala Ile Gly Ala

ACT AAC GGT CGC GAA TAC AAA GTT ATT GTA AAA GAT AAA GCT GGT AAC
Thr Asn Gly Arg Glu Tyr Lys Val Ile Val Lys Asp Lys Ala Gly Asn

TTA GCT AAA AAT GAA ATC GTT AAT GTT GCA TTC AAT GAA GAT AAA GAT
Leu Ala Lys Asn Glu Ile Val Asn Val Ala Phe Asn Glu Asp Lys Asp

CGT GTA ATT TCA ACA GTT ACA AAT GCT AAA TTC GTT GAT ACT GAT CCA
 Arg Val Ile Ser Thr Val Thr Asn Ala Lys Phe Val Asp Thr Asp Pro

GAT ACT GCA GTA TAC TTC ACA GGC GAT AAA GCA AAA CAA ATC TCT GTA
 Asp Thr Ala Val Tyr Phe Thr Gly Asp Lys Ala Lys Gln Ile Ser Val

AAA ACA AAT GAT AAA GGT GAA GCT ACA TTT GTT ATC GGT TCT GAT ACA
 Lys Thr Asn Asp Lys Gly Glu Ala Thr Phe Val Ile Gly Ser Asp Thr

GTA AAC GAT TAT GCA ACA CCA ATT GCT TGG ATT GAT ATT AAT ACT TCT
 Val Asn Asp Tyr Ala Thr Pro Ile Ala Trp Ile Asp Ile Asn Thr Ser

GAT GCA AAA CAA GGC GAC CTT GAT GAA GGT GAA CCA AAA GCA GTT GCA
 Asp Ala Lys Gln Gly Asp Leu Asp Glu Gly Glu Pro Lys Ala Val Ala

CCA ATC TCT TAC TTC CAA GCA CCA TAT CTT GAT GGC TCA GCT ATC AAA
 Pro Ile Ser Tyr Phe Gln Ala Pro Tyr Leu Asp Gly Ser Ala Ile Lys

GCA TAC AAA AAA TCA GAT CTT AAT AAA GCT GTA ACT AAG TTT GAT GGT
 Ala Tyr Lys Lys Ser Asp Leu Asn Lys Ala Val Thr Lys Phe Asp Gly

TCT GAA ACT GCA GTA TTT GCA GCA GAA TTA GTA AAC CAA AGC GGC AAA
 Ser Glu Thr Ala Val Phe Ala Ala Glu Leu Val Asn Gln Ser Gly Lys

AAA GTA ACT GGT ACT TCT ATT AAG AAA GCA ACT TAT ACA ATC TAC AAT
 Lys Val Thr Gly Thr Ser Ile Lys Lys Ala Thr Tyr Thr Ile Tyr Asn

ACT GGT GCT AAT GAT ATT AAA GTA GAT AAC CAA GTT ATC TCA CCA AAT
Thr Gly Ala Asn Asp Ile Lys Val Asp Asn Gln Val Ile Ser Pro Asn

CGT AGC TAC ACA GTA ACT TAT GAA GCT ACT TTA TCT TCT ACA GGA ACT
Arg Ser Tyr Thr Val Thr Tyr Glu Ala Thr Leu Ser Ser Thr Gly Thr

GTT ATT ACA CCT GCT AAG AAT TTA GAA GTT ACT TCA GTG GAT GGT AAA
Val Ile Thr Pro Ala Lys Asn Leu Glu Val Thr Ser Val Asp Gly Lys

ACA ACT GCT GTT AAA GTA ATT GCT ACA GGT ATT GCT GTT AAT ACA GAC
Thr Thr Ala Val Lys Val Ile Ala Thr Gly Ile Ala Val Asn Thr Asp

GGT AAA GAC TAT GCA TTT ACT GCT AAA GAA GCT ACA GCT ACA TTC ACA
Gly Lys Asp Tyr Ala Phe Thr Ala Lys Glu Ala Thr Ala Thr Phe Thr

GCT ACA AAT GAA GTT CCA AAC TCT TAC ACT GGT GTA GCT ACT CAA TTC
Ala Thr Asn Glu Val Pro Asn Ser Tyr Thr Gly Val Ala Thr Gln Phe

AAT ACA GCT GAT TCT GGT TCA AAC AGC AAC TCT ATT TGG TTT GCT GGT
Asn Thr Ala Asp Ser Gly Ser Asn Ser Asn Ser Ile Trp Phe Ala Gly

AAA AAC CCA GTG AAA TAT GCT GGT GTA TCA GGC AAA ACA TAT AAA TAC
Lys Asn Pro Val Lys Tyr Ala Gly Val Ser Gly Lys Thr Tyr Lys Tyr

TTC GGA GCT AAT GGT AAT GAA GTA TTT GGT GAA GCG GCA TGG GAA GCA
Phe Gly Ala Asn Gly Asn Glu Val Phe Gly Glu Ala Ala Trp Glu Ala

TTA TTA ACT CAA TAT GCA ACT GAA GGC CAA AAA GTA ACA ATC TCA TAT
Leu Leu Thr Gln Tyr Ala Thr Glu Gly Gln Lys Val Thr Ile Ser Tyr

AAT GTA GAT GGT GAT ACA GTT ACA TTT AAA GTA ATT AGT GCT GTT AAT
Asn Val Asp Gly Asp Thr Val Thr Phe Lys Val Ile Ser Ala Val Asn

TCT TCA ACT GAA GCT ATC AAA CCA GTT GCT CCA ACA ACA CCA GCA GCT
Ser Ser Thr Glu Ala Ile Lys Pro Val Ala Pro Thr Thr Pro Ala Ala

CCA ACT ACT GGC GCA TTA ACA TTA ACA CCA GCA GCT GGT GGT TTA GTT
Pro Thr Thr Gly Ala Leu Thr Leu Thr Pro Ala Ala Gly Gly Leu Val

GAT TTA ACA ACT GCA ACT AAC ACT TTA GGA ATT TCA TTA GCT GAT GCA
Asp Leu Thr Thr Ala Thr Asn Thr Leu Gly Ile Ser Leu Ala Asp Ala

GAT CTT AAT GTA AGT GCA ACA ACT GTT GAT ACT GCA ACT GTT TCA TTA
Asp Leu Asn Val Ser Ala Thr Thr Val Asp Thr Ala Thr Val Ser Leu

AAA GAT AGT GCA AAT AAT TCA TTA TCT CTT ACA TTA GTT GAA ACT GGT
Lys Asp Ser Ala Asn Asn Ser Leu Ser Leu Thr Leu Val Glu Thr Gly

GCT AAT ACA GGT GTA TTT GCT ACA ACT GTT CAA GCT GGT ACA TTA TCT
Ala Asn Thr Gly Val Phe Ala Thr Thr Val Gln Ala Gly Thr Leu Ser

TCT TTA ACT GCT GGT ACA TTA ACA GTT ACT TAT GCA GAT GCT AAA AAT
Ser Leu Thr Ala Gly Thr Leu Thr Val Thr Tyr Ala Asp Ala Lys Asn

GCT GCA GGT GTT GCT GAA AAT ATT ACT GCT AGC GTA ACA TTA AAG AAA
Ala Ala Gly Val Ala Glu Asn Ile Thr Ala Ser Val Thr Leu Lys Lys

ACT ACT GGA GCA ATT ACT TCT GAT ACA TTT ACA CAA GGT GTA TTA CCA
Thr Thr Gly Ala Ile Thr Ser Asp Thr Phe Thr Gln Gly Val Leu Pro

TCA GCA GCT ACA GCA GCT GAA TAT ACT TCT AAA TCA ATT GCT GCA GAT
Ser Ala Ala Thr Ala Ala Glu Tyr Thr Ser Lys Ser Ile Ala Ala Asp

TAT ACA TTT GCA ACA GGT GAA GGA TTC ACT TTA AAT ATT GAT AAT GCT
Tyr Thr Phe Ala Thr Gly Glu Gly Phe Thr Leu Asn Ile Asp Asn Ala

GGT GCT CAA GTA ATT AAC TTA GCA GGT AAA AAA GGT GCA CAA GGT GTA
Gly Ala Gln Val Ile Asn Leu Ala Gly Lys Lys Gly Ala Gln Gly Val

GCT GAT GCT ATC AAT GCT ACA TTT GCA GGT ACT GCA ACT GTT TCT GGA
Ala Asp Ala Ile Asn Ala Thr Phe Ala Gly Thr Ala Thr Val Ser Gly

GAC AAA GTA GTT ATT AAA TCA GCT ACA ACA GGT GTT GGT TCT GAA GTT
Asp Lys Val Val Ile Lys Ser Ala Thr Thr Gly Val Gly Ser Glu Val

GAA GTT ACA TTC TCT TCT GTT AAT CAA GTA TTA AAT GCA GTA GTT AAC
Glu Val Thr Phe Ser Ser Val Asn Gln Val Leu Asn Ala Val Val Asn

GGT AAA GAT CAA GTC GTT GCA GGA ACA GCT GCT ACA AAA GCA TTC ACG
Gly Lys Asp Gln Val Val Ala Gly Thr Ala Ala Thr Lys Ala Phe Thr

ATT ACT ACA GCC CTT TCT GTG GGT GAA AAA GTA GTT ATT GAT GGT GTT
Ile Thr Thr Ala Leu Ser Val Gly Glu Lys Val Val Ile Asp Gly Val

GAA TAT ACT GCT GTA GCA TTT GGA ACT GCT CCA ACA GCA AAT ACA TTC
Glu Tyr Thr Ala Val Ala Phe Gly Thr Ala Pro Thr Ala Asn Thr Phe

GTA GTT GAA TCT GCT GCT AAT ACA TTA GCT TCA GTA GCT GAC CAA GCT
Val Val Glu Ser Ala Ala Asn Thr Leu Ala Ser Val Ala Asp Gln Ala

GCA AAT CTT GCT GCT ACA ATT GAT ACT TTA AAC ACT GCA GAT AAG TTT
Ala Asn Leu Ala Ala Thr Ile Asp Thr Leu Asn Thr Ala Asp Lys Phe

ACA GCT TCT GCA ACA GGT GCT ACT ATT ACA TTA ACT TCT ACT GTA ACA
Thr Ala Ser Ala Thr Gly Ala Thr Ile Thr Leu Thr Ser Thr Val Thr

CCA GTA GGT ACT ACA ATT ACT GAA CCA GTA ATT ACA TTA AAA
Pro Val Gly Thr Thr Ile Thr Glu Pro Val Ile Thr Leu Lys

TAAGCAATTA ACTTAAAATA CTTTTAATTA TTTGCCTATT TTATAATTTC TATGACTCTA

*

TGAGATAACA ATCTCATAGA GTCTTTTTTA TTTTLAGAAC CTCTAGATAG AAAGAAATTT

GAATTTATTA TGAAATTTAT AAAGAAGTCT TGTAACCTTT TATAAGGTAA CTAGTCTAAT

TAAGAGAGTT ATGTAAAAGC AATATATATC GATTCATATT ATTTAAAAGG CTAAAATTAT

TGTTTTAACT CAAACGGGGG TGGTAACAAA AGTTAATCAA GCAGCAATGA GTTTTCTAGA

AAATATTCAT GAAATTCTGG AAATCCTTAT TGCTTTATAT GAAGCTT

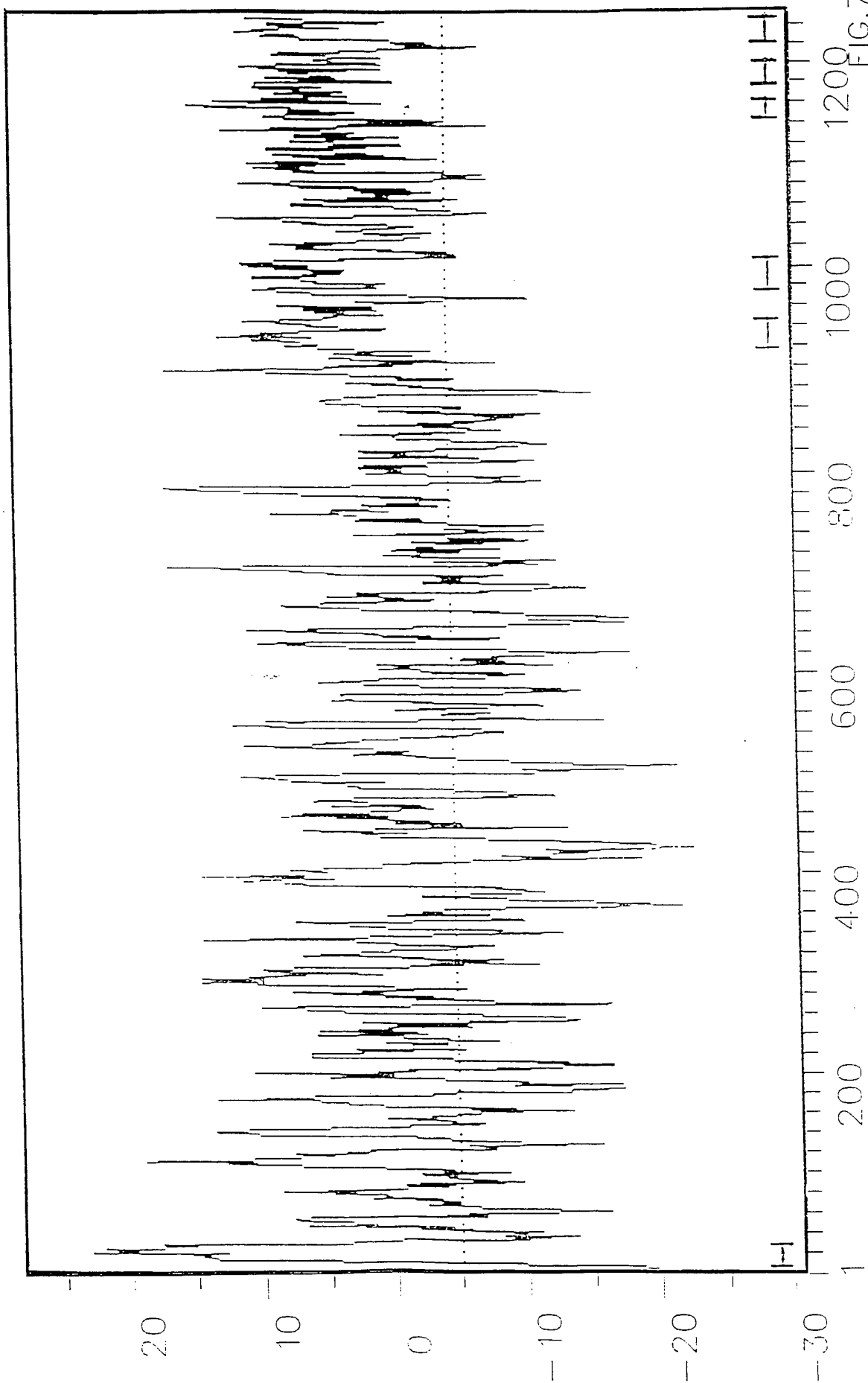

Figure 8

P-1	MAKQNKGRKFFAASATAALVASAIVPVASA	AQVNDYNKISGYAKEAVQAL
2362LM.F.....S.

P-1	VDQGVIIQGDINGNFNPLNTVTRAQAAEIFTKALELEANGDVNFKDKAGAW
2362	..A.....A.....K.IS..E..T...N.....E.....D..

P-1	YNSIAAVVANGIFEGVSATEFAPNKSLTRSEAAKILVEAFGLEGEADLS
2362	..DA...T.E.....Q.....D..E....G...

P-1	EFADASQVKPWAKKYLEIAVANGIFEGTDAN-K--LNPNNISITRQDFALV
2362T.....S.....VIK.SE..G.TN....AP.....-V

FIG. 9A

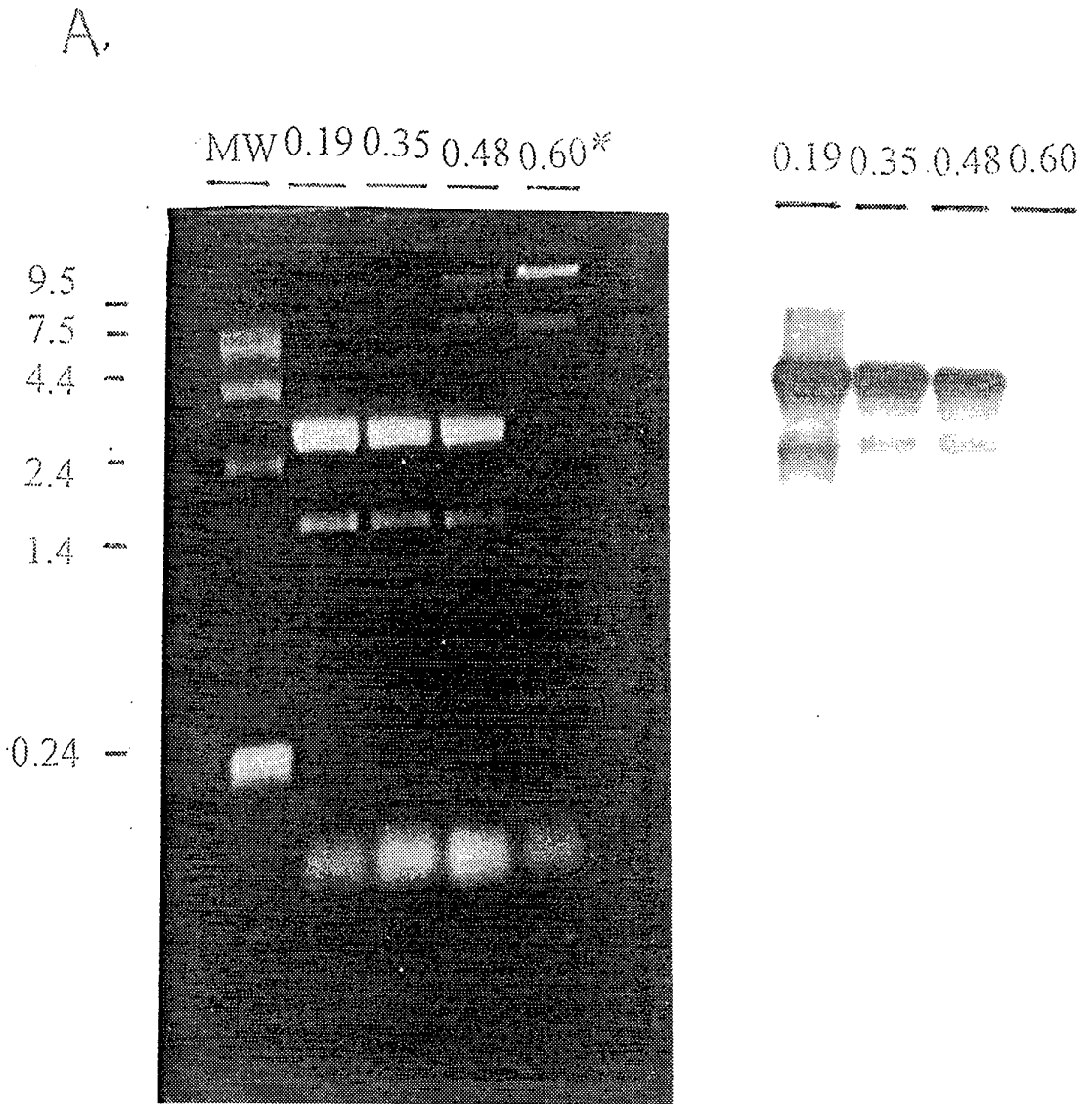
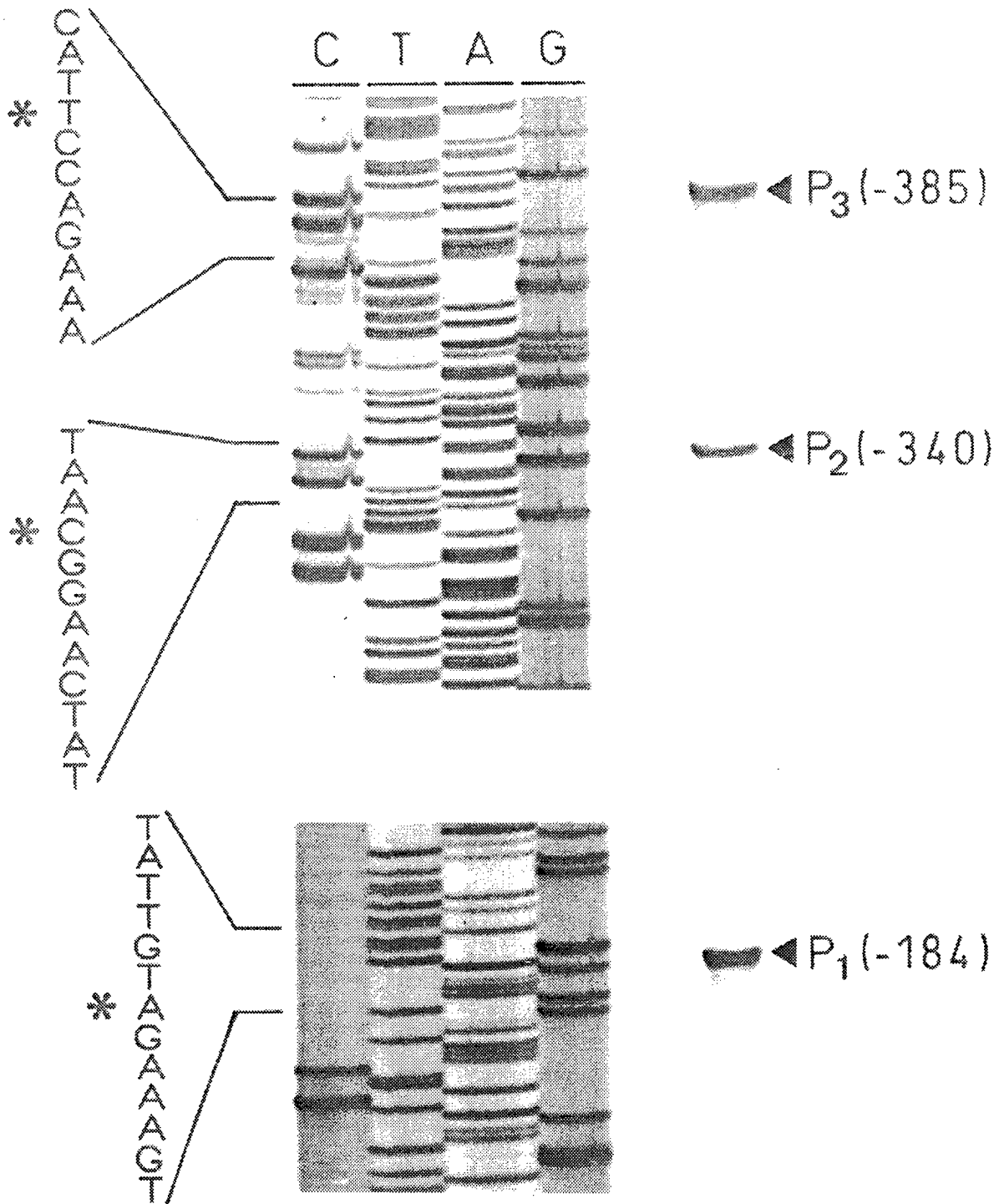

FIG. 9B



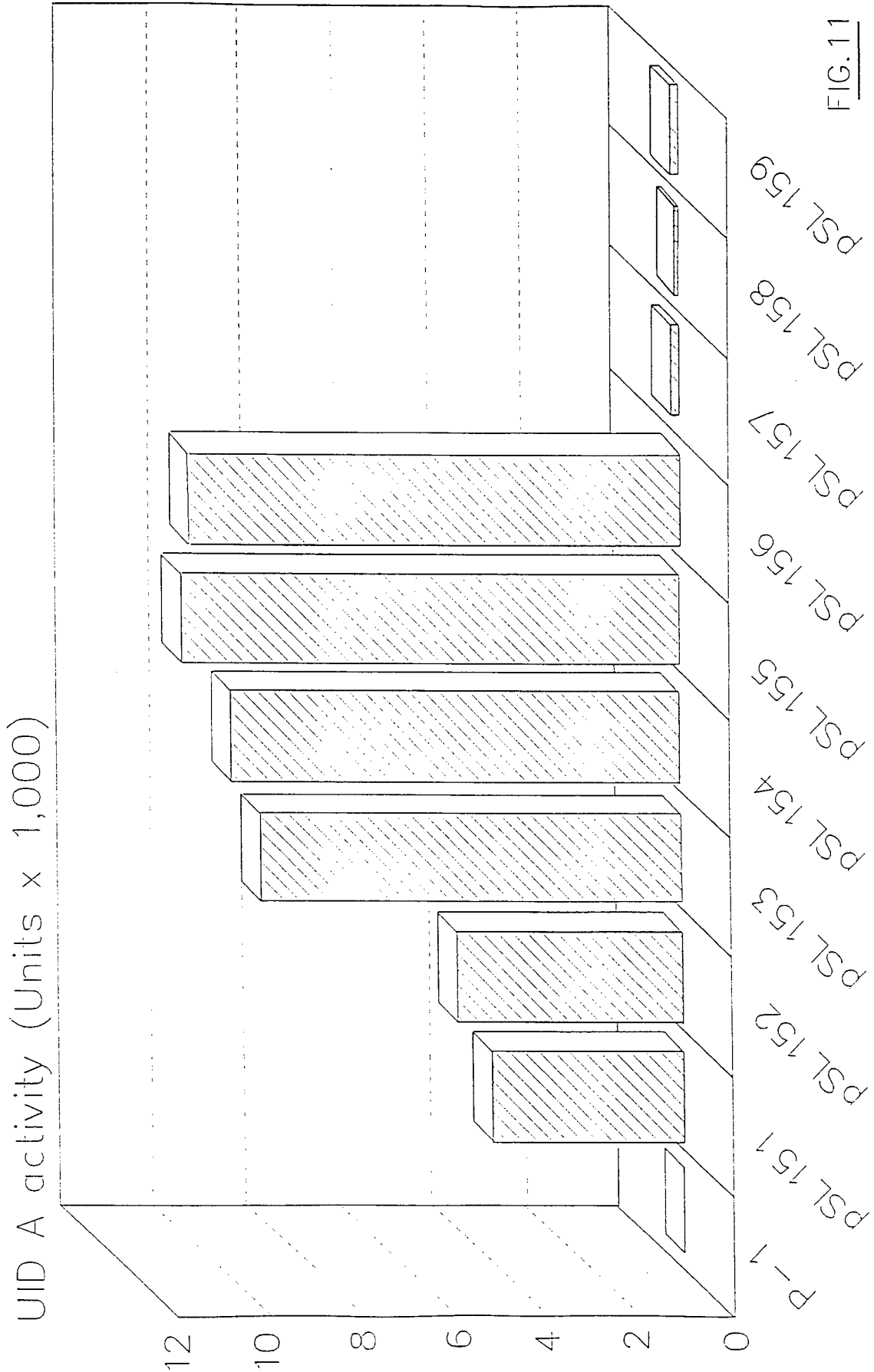

FIG. 11

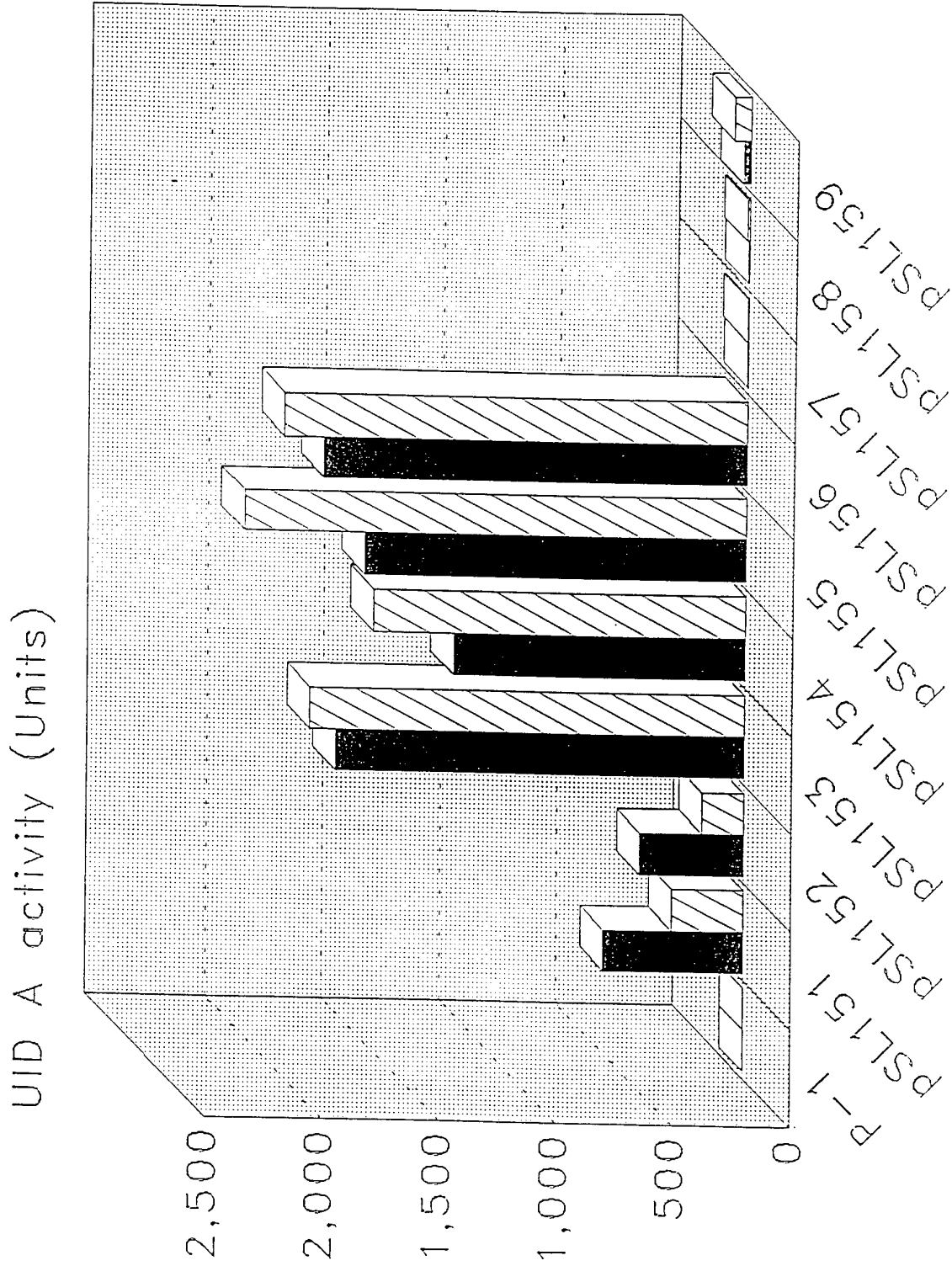

FIG. 12

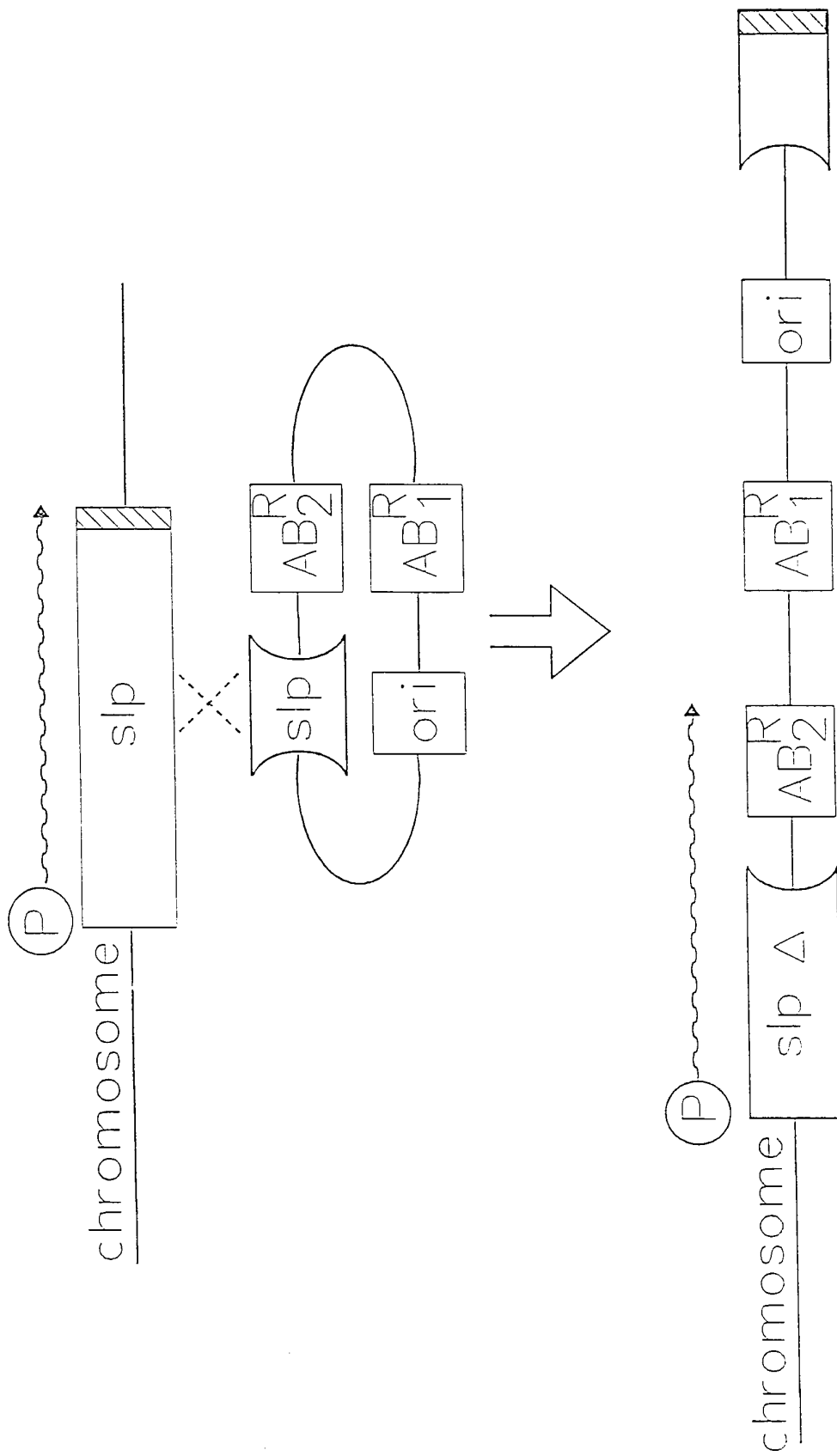
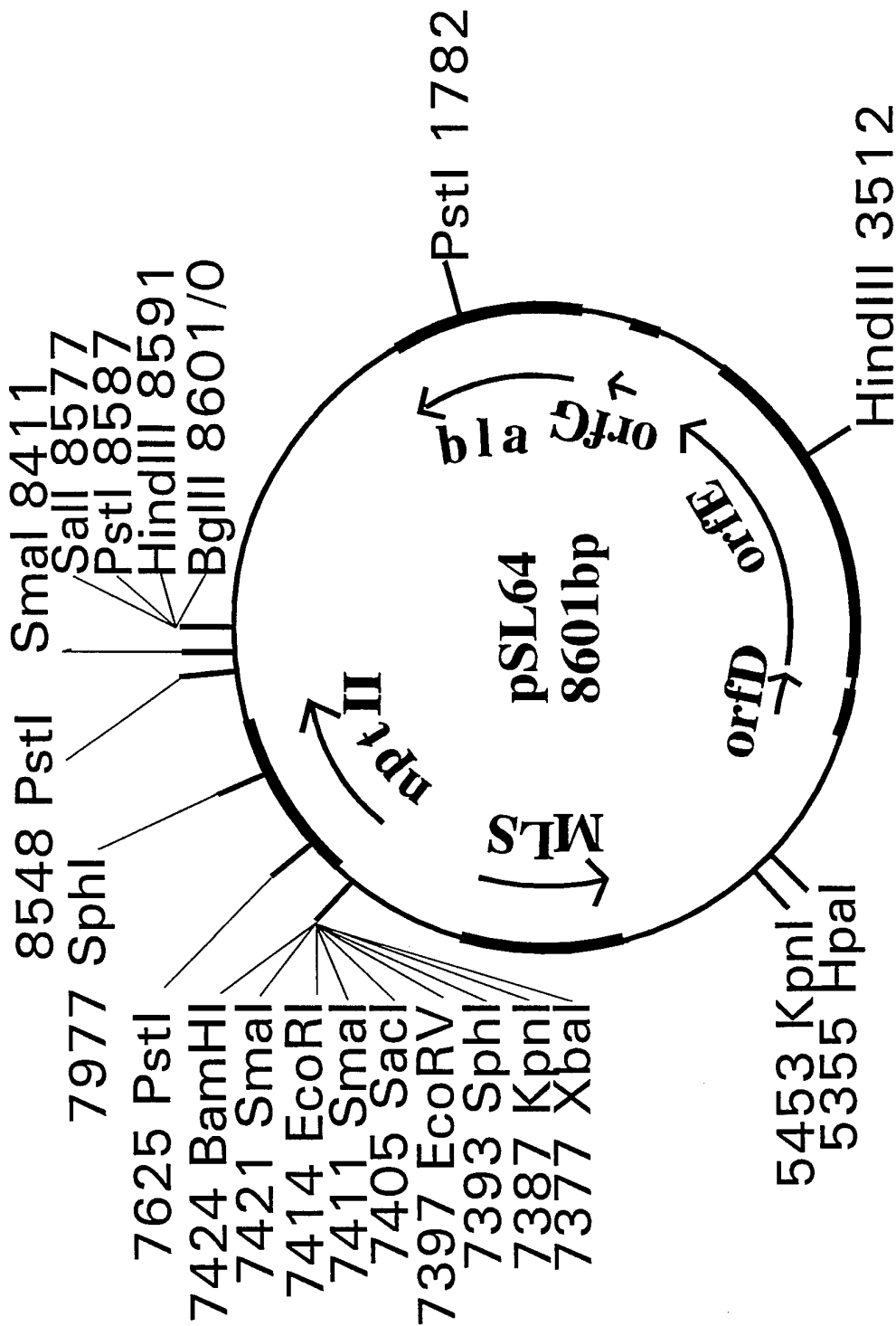

FIG. 13

FIG. 14A



1. Polynucleotide linker pSL64

XbaI SphI EcoRV EcoRI BamHI

TCTAGAGGTACCGCATCGGATATCGAGCTCTCCCGGAATCCCGGGATCCGGCCCATGATCATGTGGATTGAACAAGATGGA

KpnI

SstI SmaI

SmaI

BclI

1. Polynucleotide linker pSL101

XbaI SphI EcoRV EcoRI BamHI

TCTAGAGGTACCGCATCGGATATCGAGCTCTCCCGGAATCCCGGGATCCCTCGAGGAGCTTGATGGA

KpnI

SstI SmaI

SmaI

XhoI

FIG. 14B

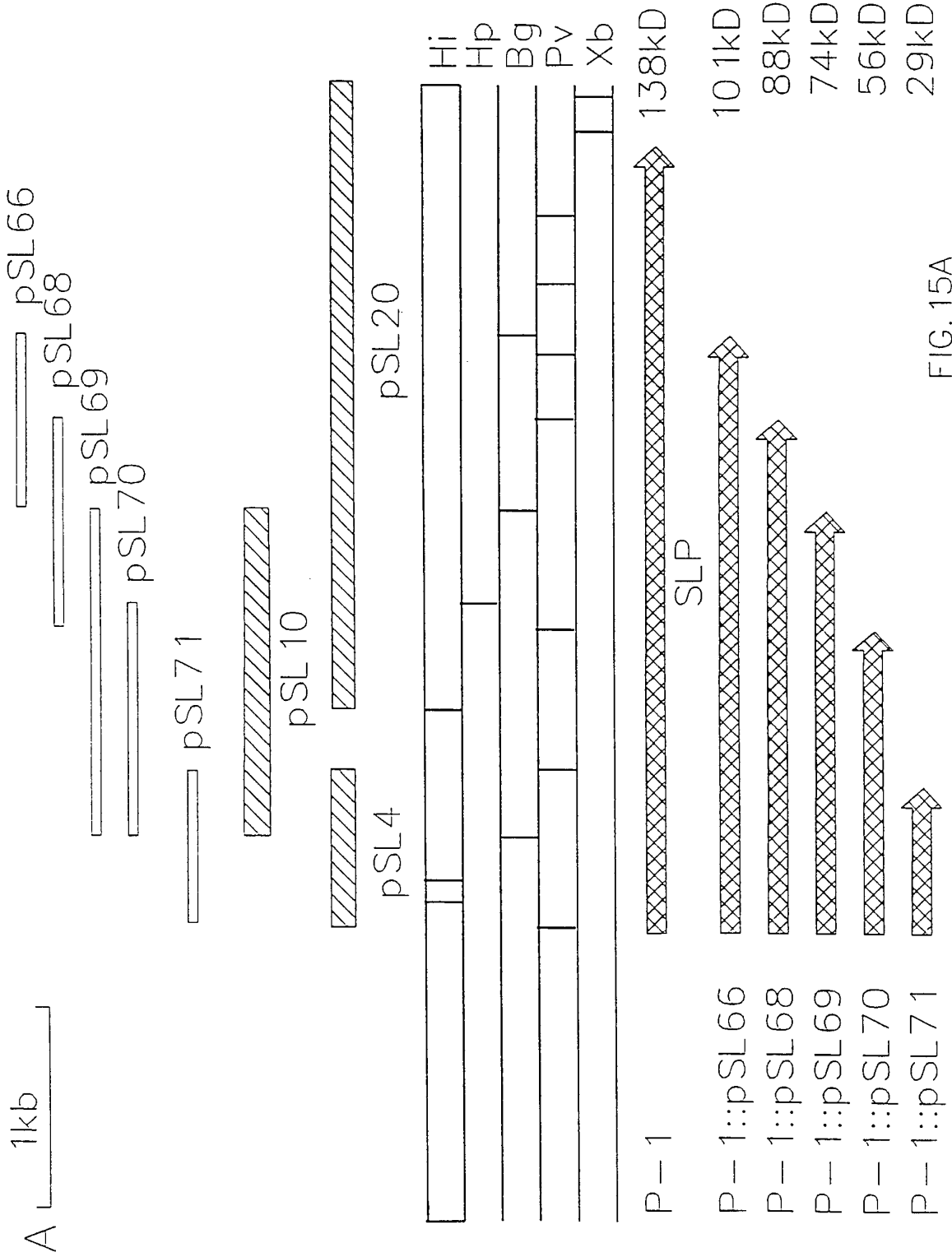
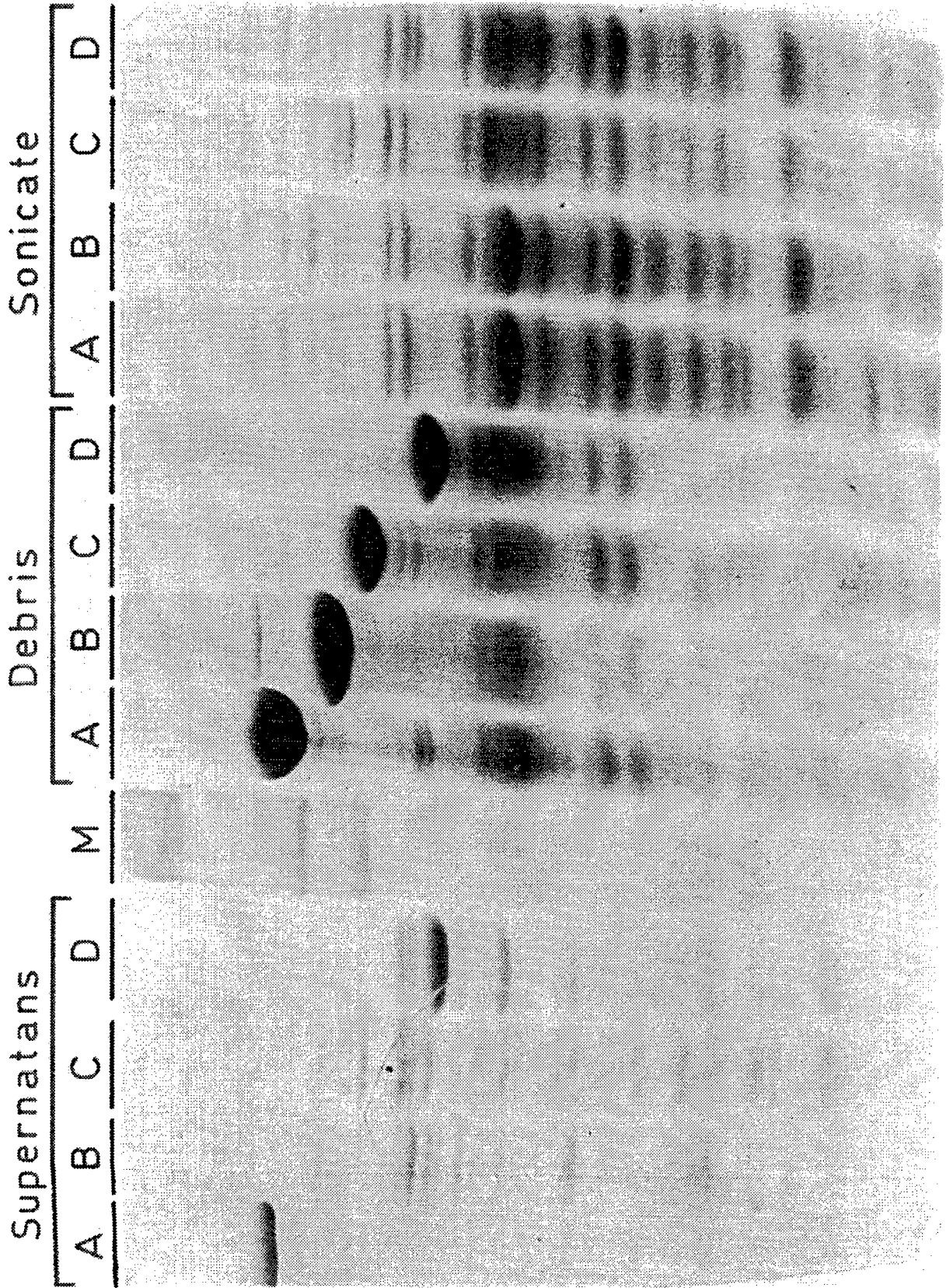

FIG. 15A



B

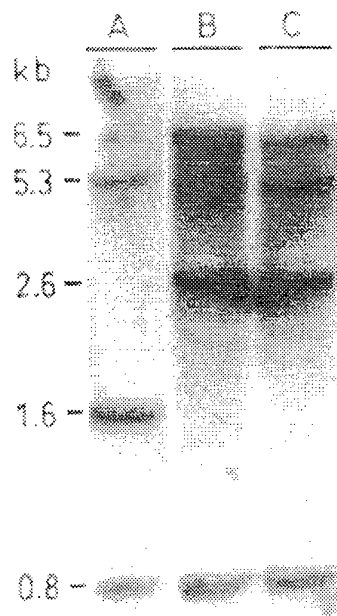

FIG. 16

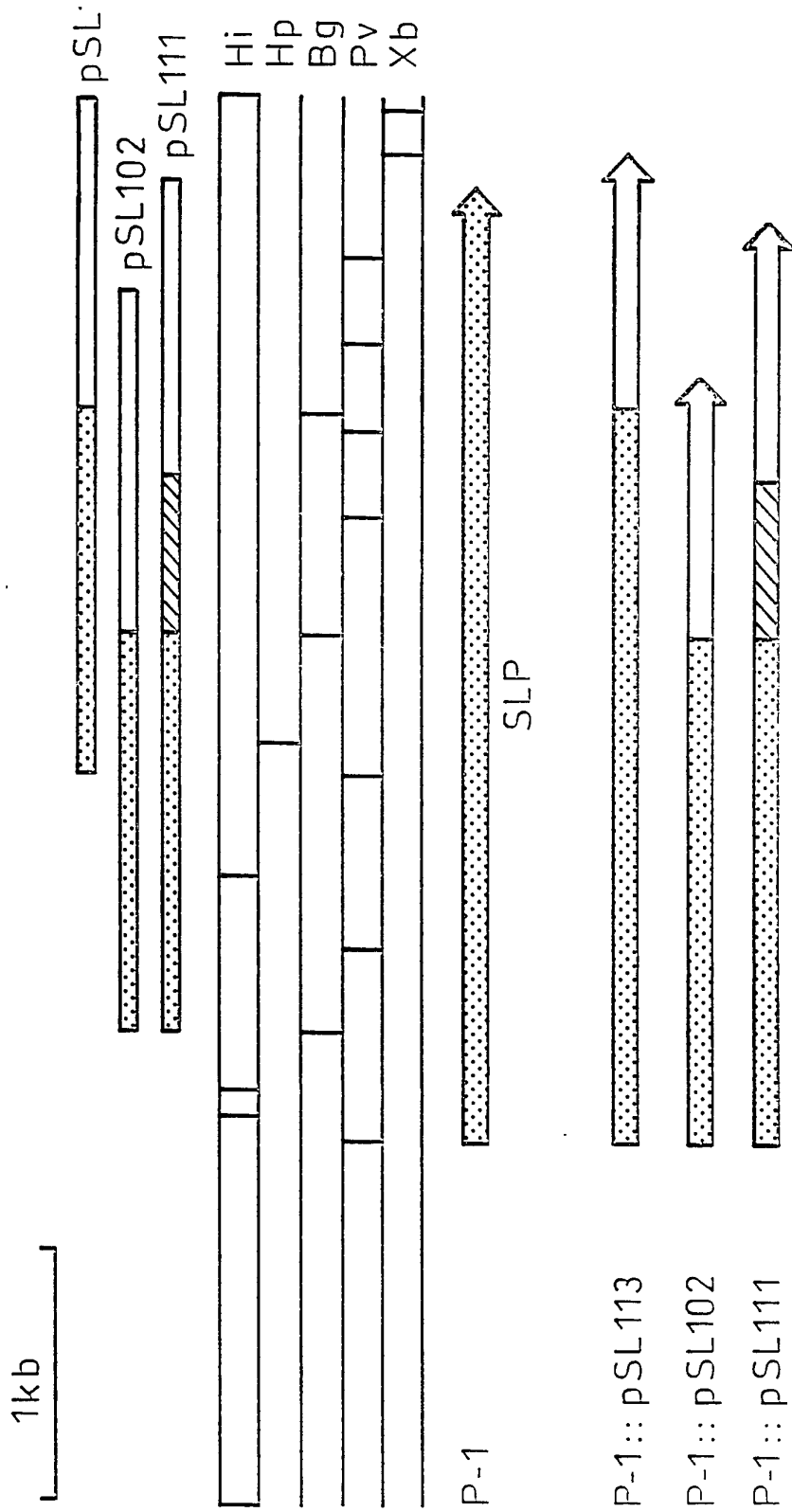

FIG. 17

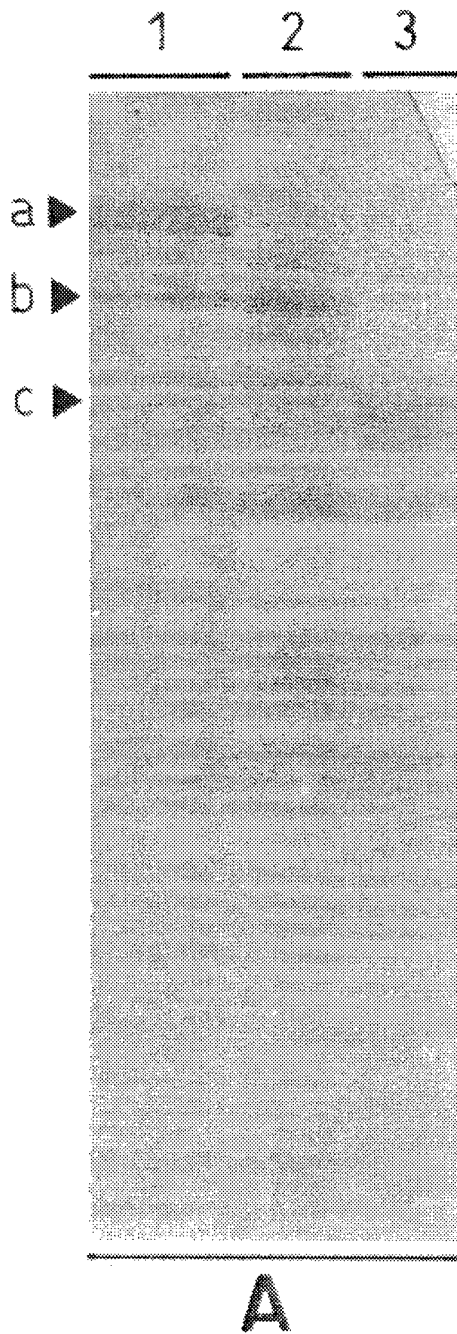

FIG. 18A

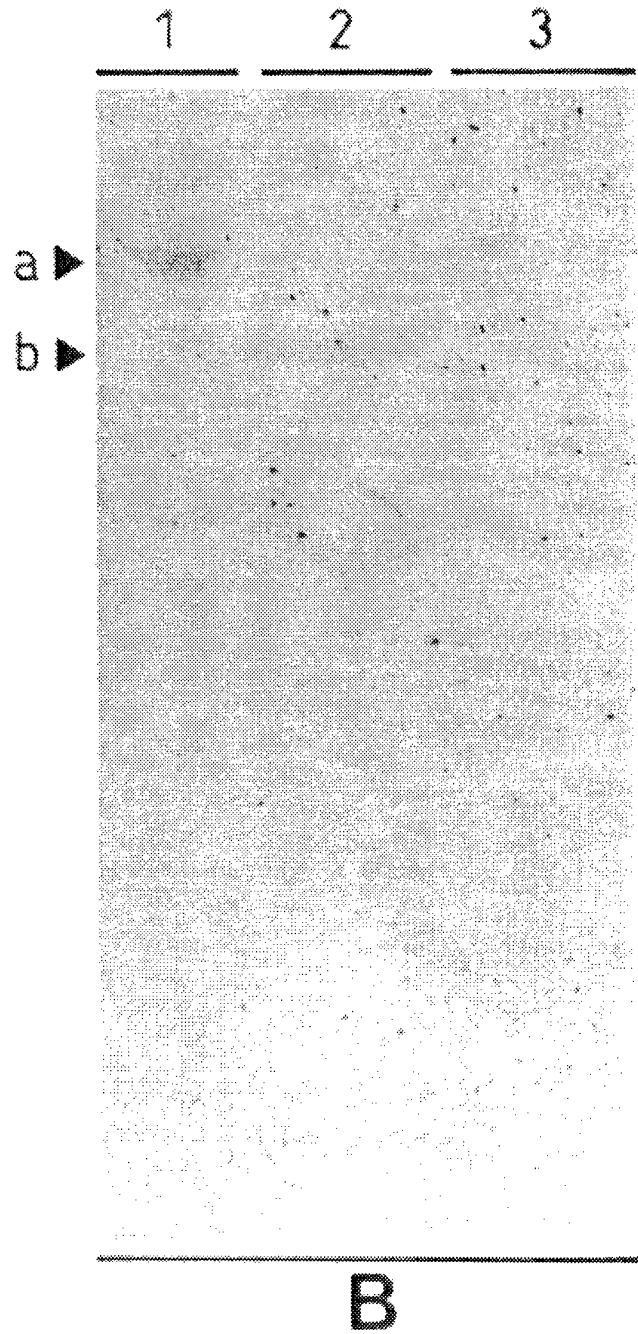

FIG. 18B

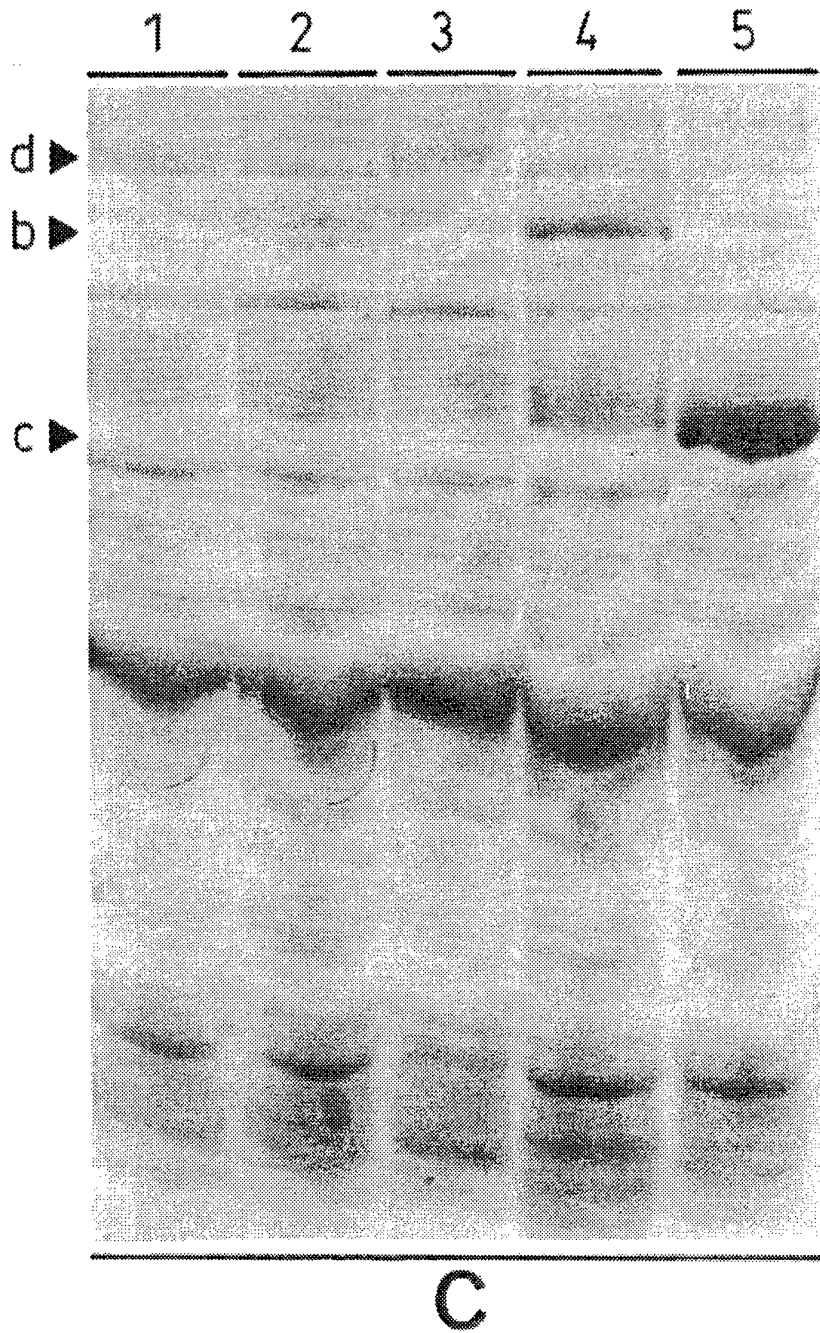
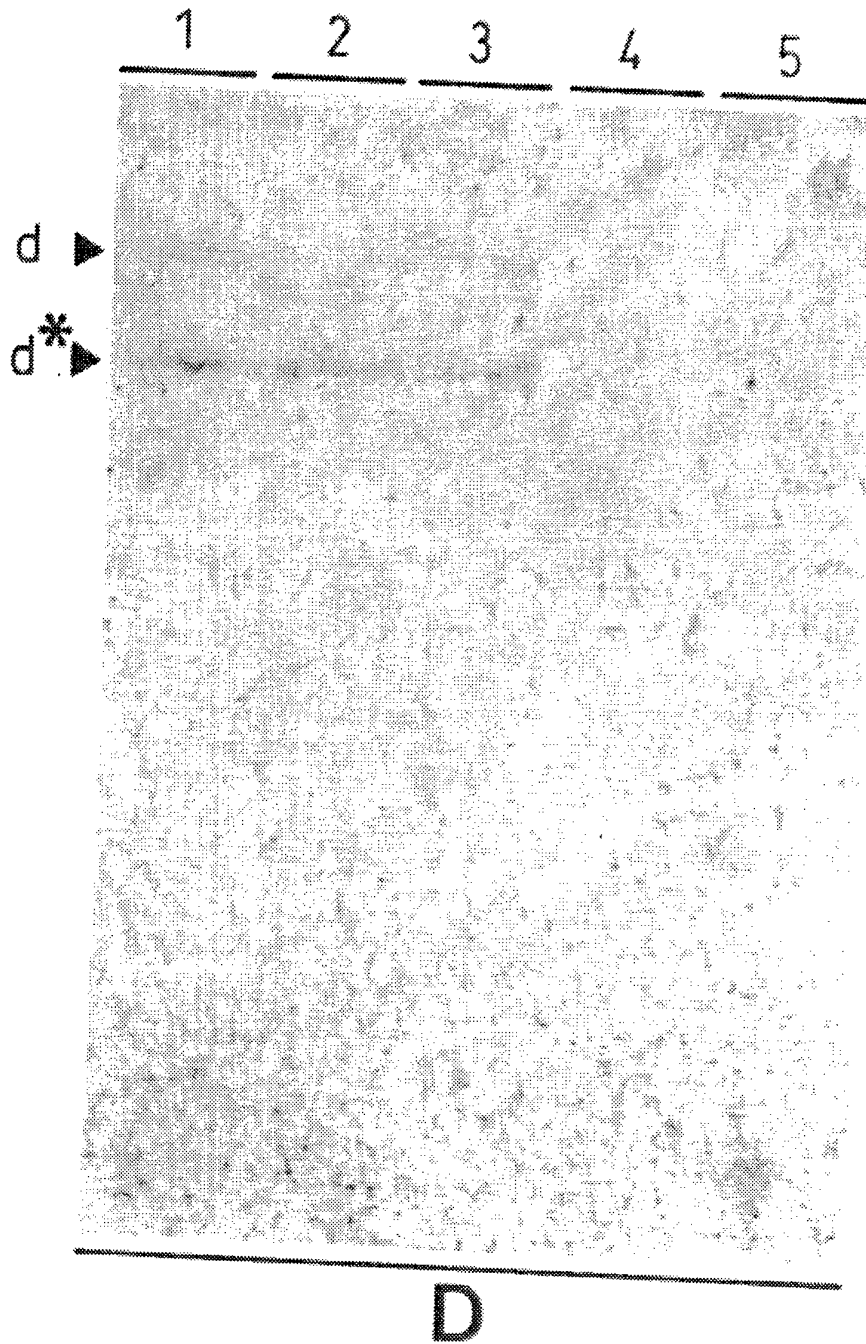

FIG. 18C



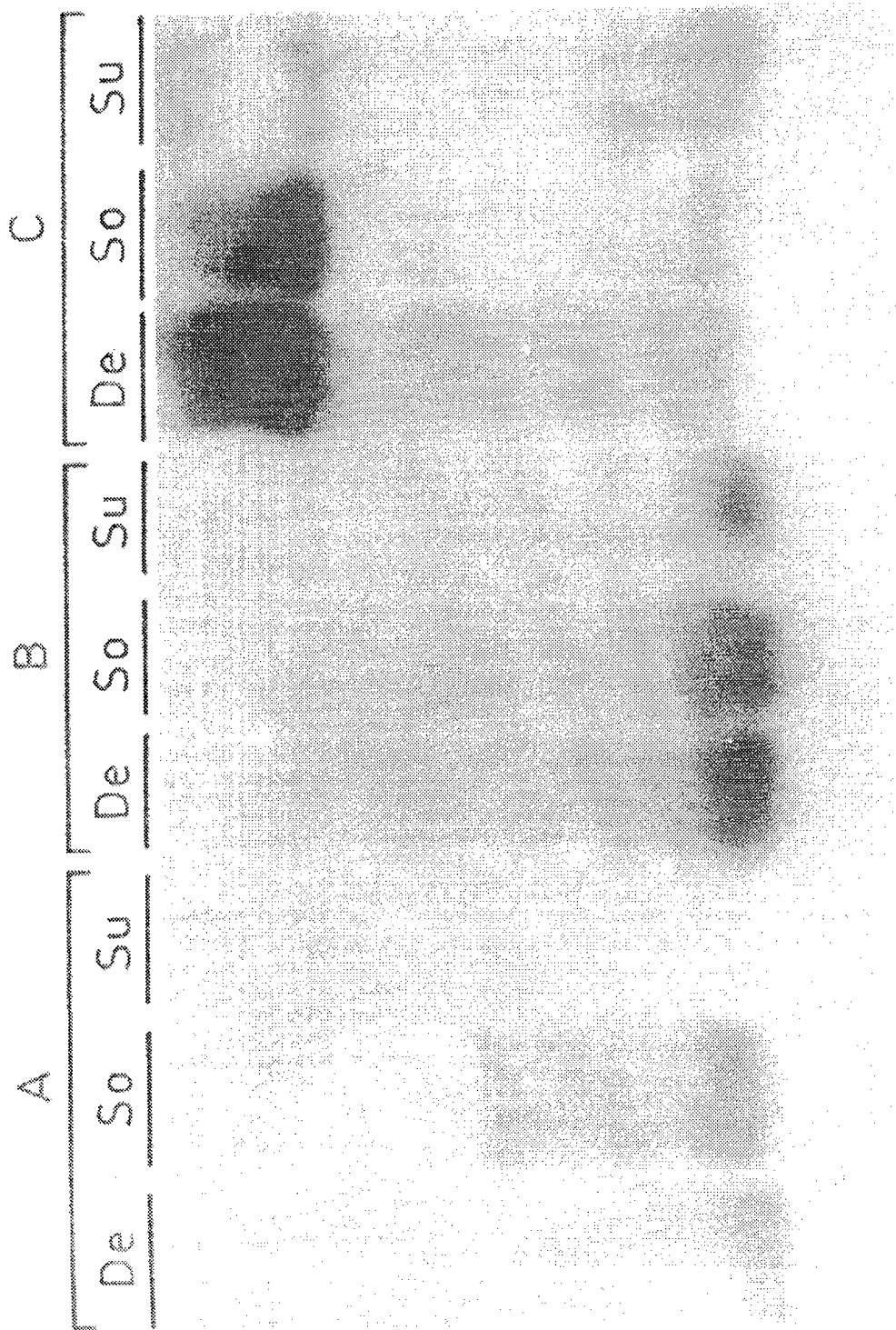
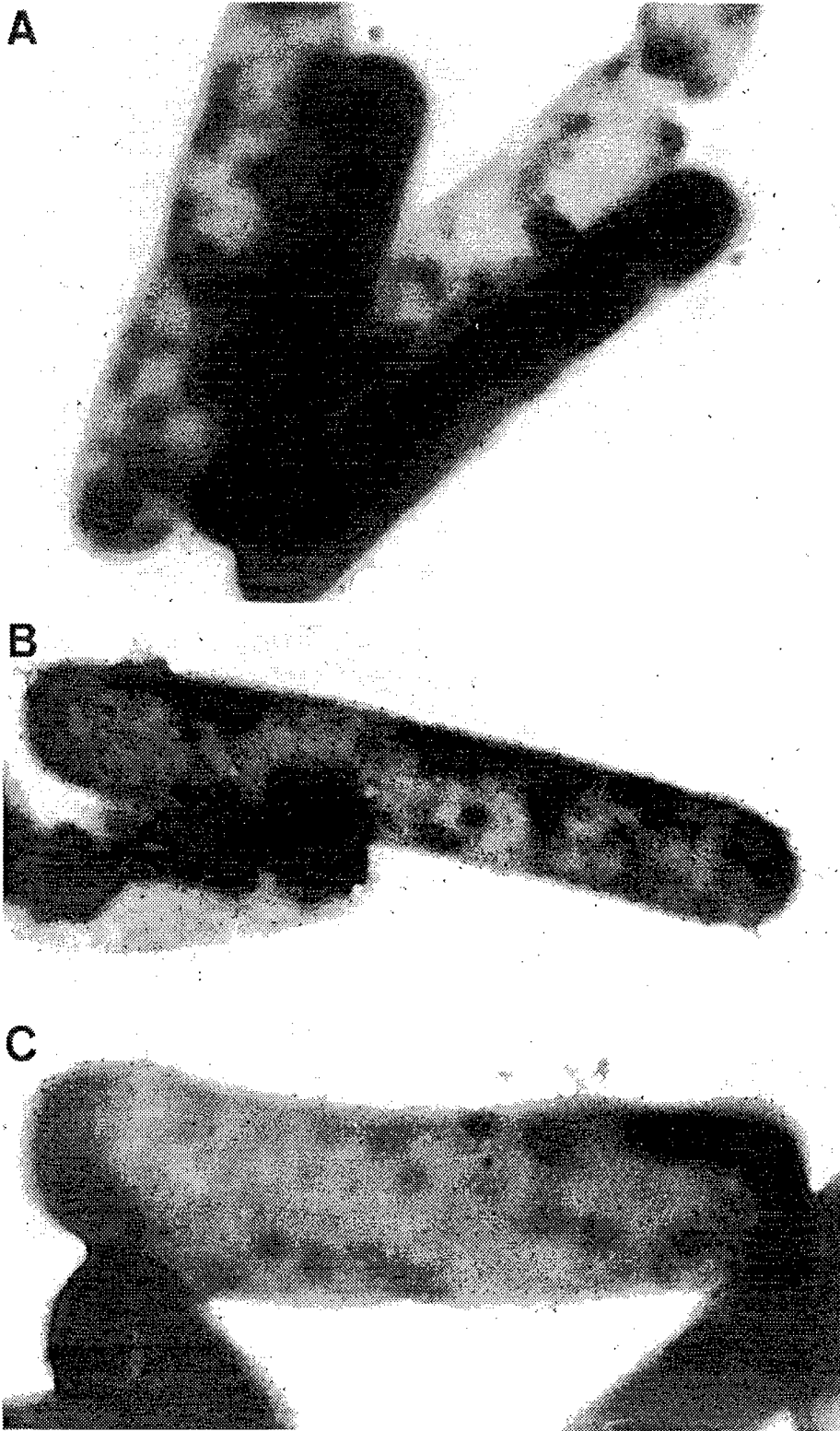

FIG. 19



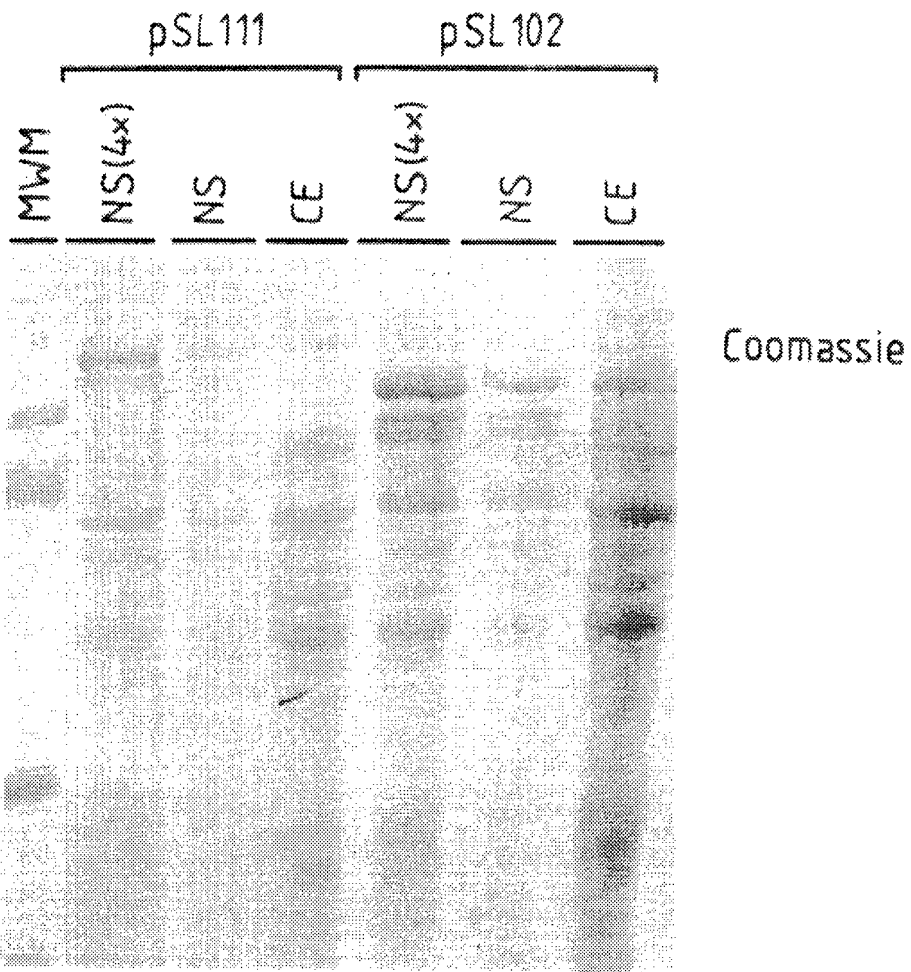
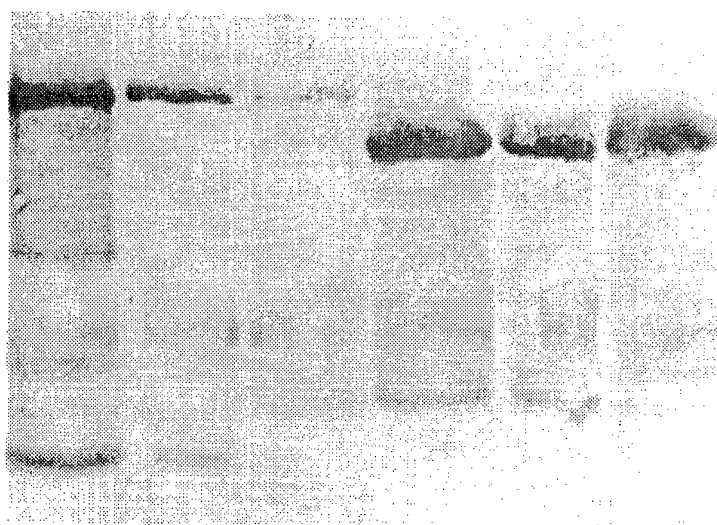
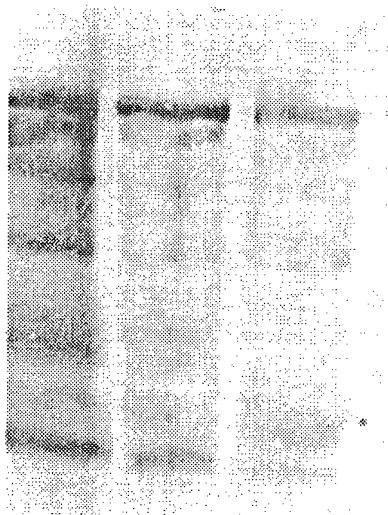

FIG. 21A

FIG. 21B



NPT II antiserum



PT antiserum

FIG. 21C