

H. L. SCOTT.
 CLAMP.
 APPLICATION FILED JUNE 5, 1915.

1,219,593.

Patented Mar. 20, 1917.

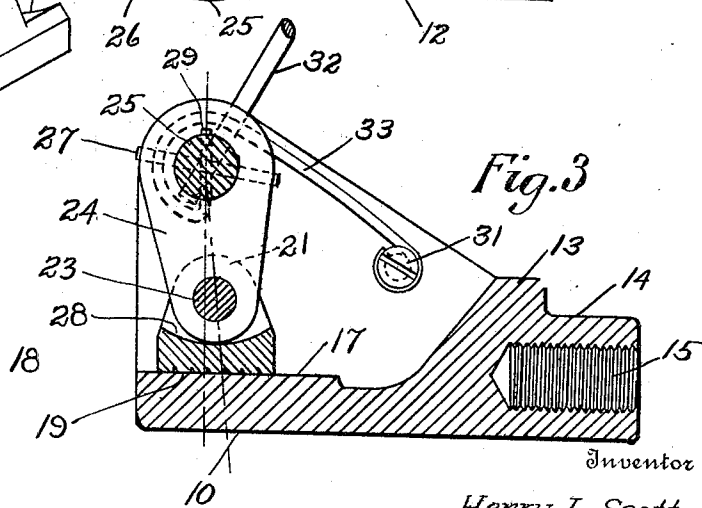
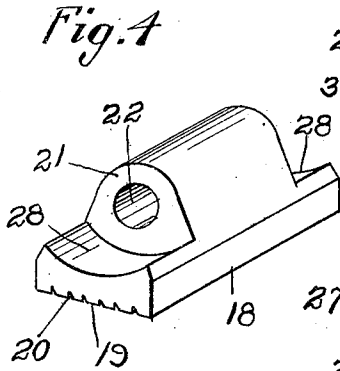
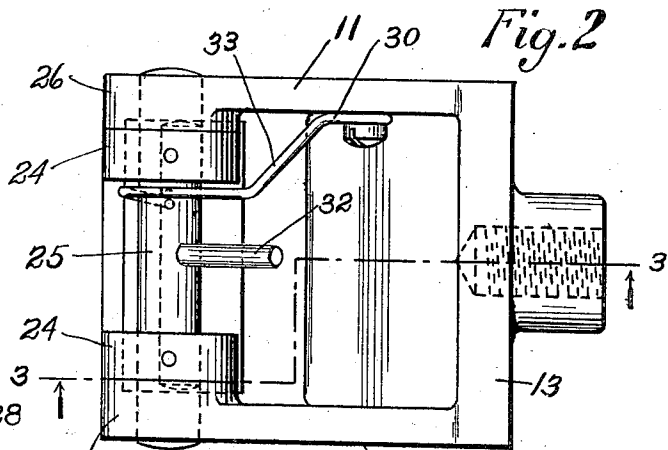
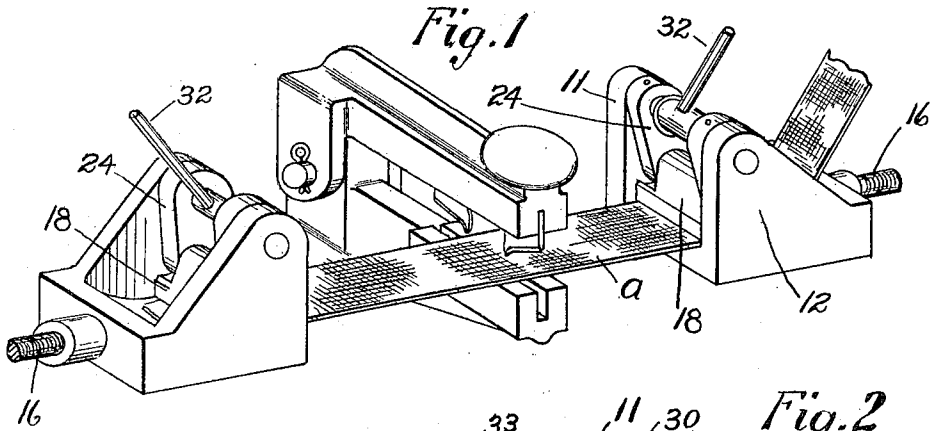

Witness
H. H. Bardsley.

Inventor
Henry L. Scott.

334
Howard E. Barlow
 Attorney

UNITED STATES PATENT OFFICE.

HENRY L. SCOTT, OF PROVIDENCE, RHODE ISLAND.

CLAMP.

1,219,593.

Specification of Letters Patent.

Patented Mar. 20, 1917.

Application filed June 5, 1915. Serial No. 32,470.

To all whom it may concern:

Be it known that I, HENRY L. SCOTT, a citizen of the United States, and resident of the city of Providence, in the county of Providence and State of Rhode Island, have invented certain new and useful Improvements in Clamps, of which the following is a specification.

This invention relates to clamps of the class employed for gripping the stock to be tested in testing machines which are used in obtaining and indicating the tensile strength of material such as fabrics, rubber and other material, and the object of this invention is to provide such a clamp that will grip and hold the material without slipping and without crushing, cutting or otherwise weakening the sample being tested.

It is found in practice very difficult to produce a clamp of this character which will engage the sample and hold the same without cutting or weakening the stock at the point where it is held, which weakening effect defeats the very object of a testing machine designed to indicate the actual breaking strength of the fabric, to produce which result the fabric must break at a point other than that where it is gripped.

In the use of the old style screw clamp, the jaws are often set so hard that they crush and weaken the material. Then again when a screw clamp is applied to rubber or other yielding or elastic material, as the stock stretches, flattens out or becomes thin by reason of the strain brought to bear upon the same, of course the grip is necessarily lessened and under such conditions the screw form of clamp often lets go. By applicant's improved clamp the force of the grip is always in proportion to the strain applied, and when this improved clamp is used on rubber or other elastic material which changes in thickness according to the strain upon the same, it is noted that the grip automatically adjusts itself to the change of thickness and the force of the bite continues to be in direct proportion to the tension of the goods.

The invention further consists in providing means whereby the pull upon the clamp is exerted in line with the plane of its biting surfaces, which of course is in the direct line of pull on the strip being tested.

Another feature of this invention is the provision of a clamp formed of a frame which is open both front and back, to en-

able a test to be taken of a short section of the sample while the opposite ends may extend through and beyond the testing clamps.

It is found in practice that the ordinary tenting clamp will not perform the function of the testing clamp, for two reasons, first, it is not strong enough to stand a breaking strain owing to the overhanging supporting arm construction; and second, the gripping edge of the gripping blade is so narrow that it would weaken and cut the fabric at the point of engagement.

This feature is overcome by the provision of a broad engaging face on the gripping shoe, the face of which shoe is designed to set flat upon the gripping base by reason of its being pivoted to the toggle member whose upper end swings in the clamp frame.

With these and other objects in view, the invention consists of certain novel features of construction, as will be more fully described, and particularly pointed out in the appended claims.

In the accompanying drawings:

Figure 1— is a perspective view showing a pair of my improved clamps as engaging a strip of fabric to be tested and a pair of knives mounted in a lever for the purpose of reducing the fabric to a predetermined width before breaking.

Fig. 2— is a plan view of my improved clamp on a larger scale.

Fig. 3— is a sectional side elevation on line 3—3 of Fig. 2.

Fig. 4— is a perspective view showing the gripping shoe.

Referring to the drawings 10 designates the base of the clamp and 11 and 12 the opposite side walls which are connected to this base. The rear portion of the clamp is provided with a thickened wall 13 which is provided with a boss 14 threaded at 15 for the reception of the tension applying screw 16, see Fig. 1. The base 10 is provided with a broad face 17 upon which the goods to be tested are laid and which serves as one of the biting surfaces.

In order to provide a gripping clamp to cooperate with the biting surface of this base 17, I have formed a shoe 18 having a broad gripping surface 19 which in some cases has a series of longitudinal slots or notches 20 extending across its face thereby providing a roughened gripping surface to prevent slipping. This shoe is shown as having a middle raised portion 21 on its

upper face drilled at 22 for the reception of the pivot pin 23. To this shoe is connected a pair of so called toggle arms 24, the ends of these arms being secured to the shaft 25 which oscillates in bearings 25 in the side walls 11 and 12.

I have shown and described a pair of toggle arms connected to opposite ends of the gripping shoe, but these two arms may be connected together as one if desired to produce the same general effect.

These arms are shown as connected to the shaft 25 by being pinned at 27 thereto, but in order to obtain the maximum gripping strength between the arms and the shoe, I have milled out the surfaces 28 at the ends of the shoe, so that the ends of the arms may rest thereon without being obliged to depend upon the strength of the pin 23 to obtain the desired binding pressure upon the shoe. It will be noted from the construction above described that the distance between the biting face 19 of the shoe, and the pivot point of the toggle arm on shaft 25, as measured on the center line through this shaft and the pivot pin 23, is slightly greater than the shortest distance between the pivoting point on the shaft 25 and the biting surface in the clamp base.

In some cases especially where this clamp is employed in an upright testing machine, I have found it advisable to provide a spring for holding the shoe normally in closed position. Therefore to accomplish this, I have arranged a wire spring 33 coiled over the shaft 25 with its end 29 passing upward through said shaft; the opposite end 30 of this wire is bent laterally, see Fig. 2, and connected by a screw 31 to the side walls of the clamp. In some cases, I have found it advisable to provide a handle 32 for operating this shoe which has been done by drilling a hole through the shaft 25 and inserting the bar 32 therein.

In the operation of my improved testing clamp, I have found it advisable to provide side walls connected to the base portion for two reasons; first, such walls provide the greatest strength at the point where the greatest strain is applied which is the line of force produced by the bite upon the goods, and second the side walls permit both the front and rear portion of the clamp to be open, so as to permit the testing of a small section of a long strip, ends of which may pass completely through the clamp between the walls thereof.

It is found in practice extremely difficult to obtain a clamp which will not injure the fabric in applying a pull great enough to rupture the same, and it has been found by careful experiment that substantially a toggle action of this clamp grip through a broad faced shoe, is about the only construction which fulfils the requirements of prac-

tical fabric testing apparatus, and by the use of a broad faced clamping shoe, it is absolutely necessary that the shoe should be pivotally mounted in the swinging toggle arms in order that its surface may always remain parallel with the plane of the cooperating gripping surface in the base regardless of the angle of the arms.

Then again in order to obtain correct results from a clamp of this character, it is found that the pull should be exerted in a line substantially on the plane of the gripping surfaces which I have accomplished by inserting the tension screw 16 at the point 15 in the rear of the clamp frame. By these means the strip of fabric *a* under tension between the clamps, pulls absolutely straight from one to the other, and that without drawing over corners or sharp edges which would tend to abrade and weaken the fabric. These clamps are particularly adapted to be used in a machine of the character described in my co-pending application Serial No. 1460, filed January 9, 1915.

I have shown and described one form of frame for my improved testing clamp but any construction of clamp having a toggle joint action upon a broad faced shoe will fall within the spirit and scope of my invention.

I claim:

1. A clamp of the character described comprising a base having a biting face, a supporting frame connected to said base, a gripping shoe having a broad engaging face cooperating with that of the base and an arm pivoted to said frame and to said shoe, the latter being free to swing on said pivot to lie parallel with the surface of said base irrespective of the angle of said arm whereby a biting toggle action is provided between said biting surfaces when a strain is applied on the goods gripped between them.

2. A clamp of the character described comprising a frame having a base with a broad biting face, a gripping shoe having a broad biting face cooperating with that of said base, an arm pivoted in said frame and to said shoe, said frame being open both front and back to permit the material to be tested to pass through the back thereof, and means whereby a pulling strain may be applied to said clamp substantially on a line with its biting surfaces.

3. A clamp of the character described comprising a base having a broad biting surface, side frames connected to said base, a gripping shoe having a broad engaging face cooperating with that of the base, an arm pivoted to said frames and to said shoe whereby a biting toggle action is produced between said biting surfaces when a strain is produced on the goods gripped between them, and a spring for holding the swinging shoe normally closed.

4. A clamp of the character described

comprising a base having a broad biting surface, side frames connected to said base, a gripping shoe having a broad engaging face cooperating with that of the base, and a toggle member pivoted to said side frames and to said shoe whereby a biting toggle action is produced between said biting surfaces when a strain is produced on the goods gripped between them, a spring for holding the swinging shoe normally closed and a handle for operating said shoe. 10

In testimony whereof I affix my signature.

HENRY L. SCOTT.

Copies of this patent may be obtained for five cents each, by addressing the "Commissioner of Patents, Washington, D. C."