

No. 725,320.

PATENTED APR. 14, 1903.

M. L. CROSS.
BEDSTEAD.

APPLICATION FILED JUNE 19, 1902.

NO MODEL.

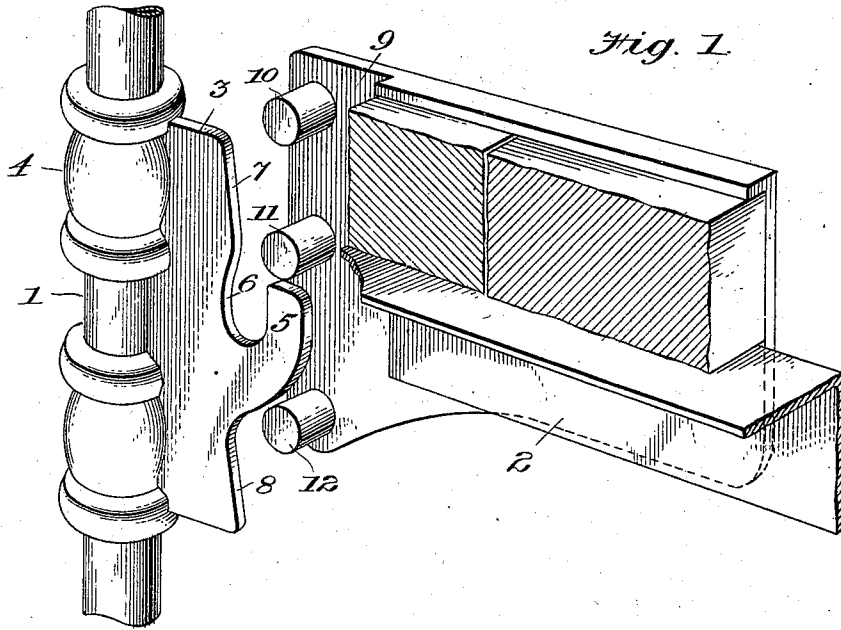

Fig. 1.

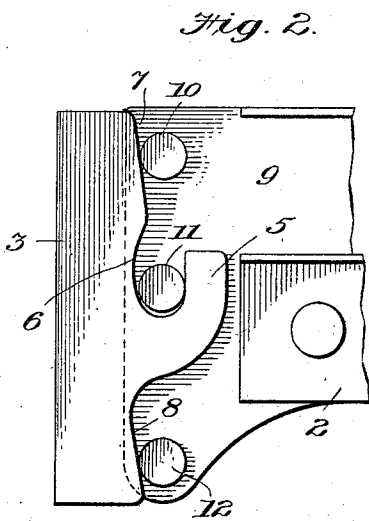

Fig. 2.

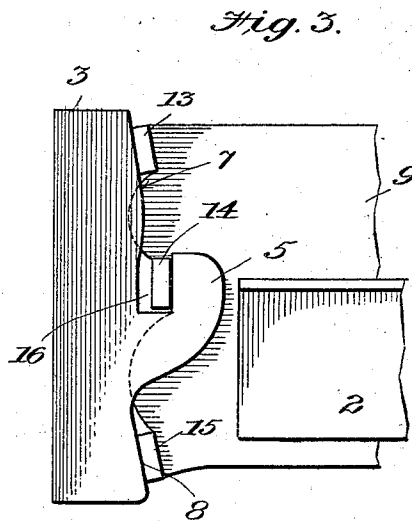

Fig. 3.

WITNESSES:

M. L. Cross.
Edw. W. Vaile Jr.

INVENTOR:

Milton I. Cross,
by Homer Pettit.
ATTORNEY:

UNITED STATES PATENT OFFICE.

MILTON L. CROSS, OF PHILADELPHIA, PENNSYLVANIA.

BEDSTEAD.

SPECIFICATION forming part of Letters Patent No. 725,320, dated April 14, 1903.

Application filed June 19, 1902. Serial No. 112,270. (No model.)

To all whom it may concern:

Be it known that I, MILTON L. CROSS, a citizen of the United States, and a resident of the city of Philadelphia, State of Pennsylvania, have invented certain new and useful Improvements in Bedsteads, of which the following is a full, clear, and exact description, reference being had to the accompanying drawings, forming part of this specification.

My invention relates to certain improvements in bedsteads, and particularly to an improved fastening means for securing the side rails to the bed-posts.

My invention is particularly adapted to metallic bedsteads, and has for its object to provide a simple and effective coupling whereby the parts are rigidly held together and the wobbling or sagging usually found in beds of this character completely eliminated.

The invention consists in the construction and arrangement of parts, such as hereinafter fully described, and particularly pointed out in the claims made hereto.

Referring to the accompanying drawings, in which similar numerals of reference are used to indicate similar parts, Figure 1 is a perspective view of one corner of a bedstead, showing the side rail and corner-post constructed in accordance with my invention, the two parts being disconnected, and the cross-rails, which connect the two side rails, being shown in section. Fig. 2 is a detail in side elevation, showing the hook-section carried by the post and the stud-plate carried by the side rails, these parts being shown in a locked position. Fig. 3 is a similar view illustrating a slight modification in form.

Referring particularly to the said drawings, 1 designates one of the corner-posts of a metallic bedstead, and 2 designates the side rail. To each of the corner-posts is secured a plate 3, which may be welded to the said posts and further secured thereto by means of the chill-iron 4. This plate 3 is provided on its inner edge with a hook 5, which is disposed about centrally to the height of said plate. The inner wall of the hook-slot is curved inwardly, as at 6, and the upper edge of the plate 3 is inclined upwardly toward the post, as shown at 7. The lower edge of the plate 3 below

the hook is also inclined on substantially the same angle as the upper edge, thus forming an outwardly-tapering edge 8.

The stud-plate 9 is of a height corresponding to that of the hook-carrying plate 3 and may be either bolted or riveted to the side rail or else formed integral therewith. Projecting from the inner surface of the plate 9 are the studs 10, 11, and 12, which are all in the same vertical plane. These studs are preferably formed integral with the plate 9 and afterward turned up, so as to make them perfectly true.

In assembling, the side rails are lifted until the central stud 11 clears the bill of the hook 5, when it is allowed to drop into the slot of the hook. The curved wall 6 of this slot permits the stud 11 to pass easily into the said slot, and just before it becomes seated in the same the upper and lower studs 10 and 12, respectively, coming in contact with the inclined edges 7 and 8 of the hook-plate, serve to force the stud-plate away from the post, and thereby cause the central stud 11 to bind against the outer wall of the hook-slot. The binding or wedge effect is thus on the inner surface of the central stud 11 and against the hook-bill and on the opposite side of the upper and lower studs 10 and 12 and against the tapering edges 7 and 8. By binding these parts in two directions, as above described, an extremely-rigid connection or coupling is effected and the wobbling or sagging of the bedstead thereby completely obviated. By placing the studs 10, 11, and 12 in the same vertical plane or lines at right angles to the direction of the lengths of the side rails the joints between the hook-plates 3 and the stud-plates 9 are rendered incapable of being separated or loosened from engagement by wrenchings or twistings of the head or foot portions of the bed-frame. When the studs and their corresponding engaging portions are not in alinement, there is a tendency for two of the studs to rotate about one of the others as a fulcrum, and thereby work away from the corresponding engaging parts, which ultimately results in the portions of the bed falling apart. By locating the studs in line the tendency to rotate is confined to a direc-

tion at right angles to the engaging edges of the hook-plates and obviates any tendency to separate.

Another advantage arising from my construction is that the connection may be easily uncoupled, as the central stud does not become so tightly wedged in the hook as to make it hard to disengage the same, it binding only on one side of the hook-slot, and as soon as the side rails are raised slightly the inclined edges of the plate 3 permit the stud-plate to be moved outwardly toward the parts, and thereby release the binding of the studs.

In Fig. 3 of the drawings I have illustrated a slightly-modified construction of the parts, in which the principle and operation remain unchanged from the constructions heretofore described. In this figure the plate 9 instead of having the turned studs 10, 11, and 12 provided thereon is made of struck-up steel having the lugs or projections 13, 14, and 15 formed on its outer edge. The upper lug 13 and the lower lug 15 are each inclined, as shown, at an angle substantially the same as the edges of the hook-plate 3. The hook 5 on the plate 3 is provided with an angular slot 16 in place of the rounded one shown in the preferred construction in order that the central lug may readily enter therein. In assembling or coupling the parts the action is substantially the same as before described. The lugs 13 and 15 taking against the inclined edges 7 and 8 of the plate 3 force the central lug 14 against the bill of the hook 5, thus wedging the parts firmly in position.

I am aware that double hooks carried by the bed-post, adapted to be engaged by pins carried by the side rails, have been used in devices of this character and am also aware that numerous devices have been made for connecting and wedging these parts together. Hence I do not desire to claim the use of same broadly, but only in the manner set forth in the appended claims.

Having thus described my invention, what I claim, and desire to secure by Letters Patent, is—

1. In a bedstead, the combination with post-sections and rail-sections, of hooks and in-

clined edges carried by one set of said sections, a series of three alined projections carried by each of the other sections and adapted to engage said hooks and inclined surfaces.

2. In a bedstead, the combination, corner-posts, a plate extending from each of said posts, hooks disposed on the edges of said plates, inclined edges on said plates adjacent said hooks, side rails, projections extending from said side rails adapted to engage said hooks, and projections adapted to bear against the inclined edges of the hook-plates all of said projections corresponding to each post being in alinement in a direction at right angles to the length of the side rails.

3. The combination in a bedstead, of a corner-post, a vertically-disposed plate extending therefrom, a hook extending from the edge of said plate, a downwardly-inclined edge tapering outwardly from the bottom of said hook, an upwardly-inclined edge tapering from the hook-slot inwardly toward the post, a side rail, a stud-plate carried by the side rail, an intermediate stud projecting therefrom adapted to engage the hook on the post-section, and upper and lower studs adapted to engage the inclines above and below the hook respectively, for the purpose described.

4. The combination with the corner-post, of a vertically-disposed plate 3, a hook formed on the intermediate edge of said plate, a curved-out section 6 on the inner wall of the hook-slot, a tapering upper edge 7, above the hook-slot inclined upwardly toward the post, a tapering lower edge 8, below the hook inclined outwardly toward the bottom of the plate, a side rail, a plate 9 carried by the side rail, an intermediate stud 11, carried by said plate adapted to engage the hook-slot, a stud 10, above the intermediate stud, and a stud 12 below said intermediate stud each adapted to engage the respective inclines 7 and 8 of the hook-plate, substantially as described.

In witness whereof I have hereunto set my hand this 16th day of June, A. D. 1902.

MILTON L. CROSS.

Witnesses:

JNO. T. CROSS,
CHAS. K. BENNETT.