

T. KUNDTZ.
SEWING MACHINE CABINET.

No. 524,090.

Patented Aug. 7, 1894.

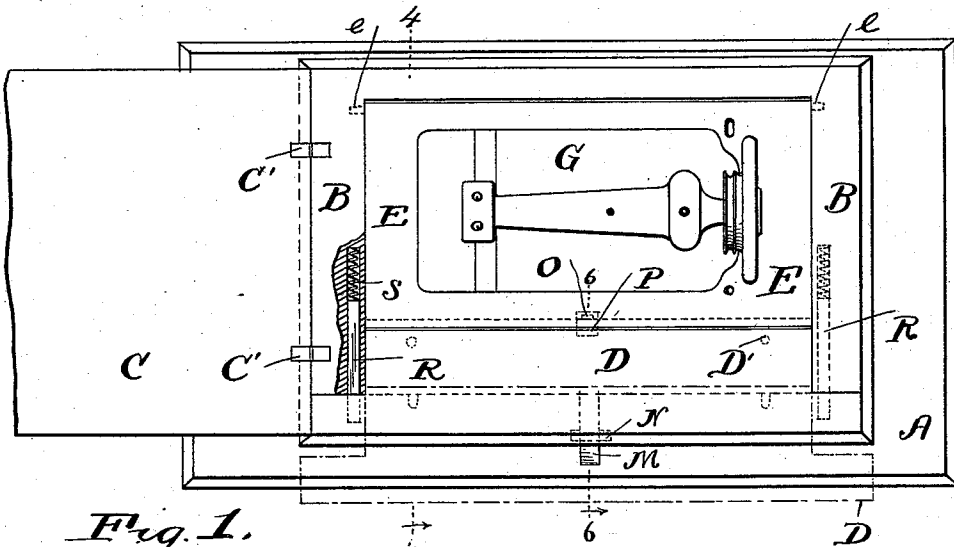

Fig. 1.

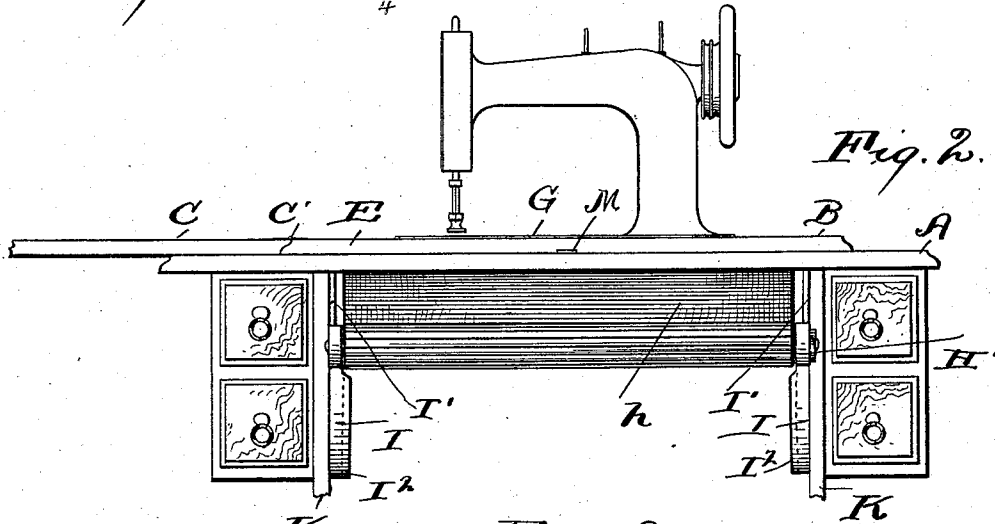

Fig. 2.

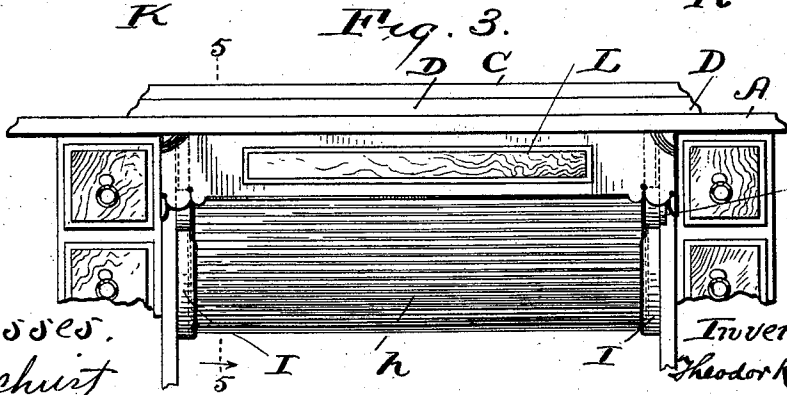

Fig. 3.

Witnesses.
E. B. Gilchrist
Attorney

Inventor.
Theodor Kundtz

By *Seppelt & Seppelt*
 the Attorneys.

T. KUNDTZ.
SEWING MACHINE CABINET.

No. 524,090.

Patented Aug. 7, 1894.

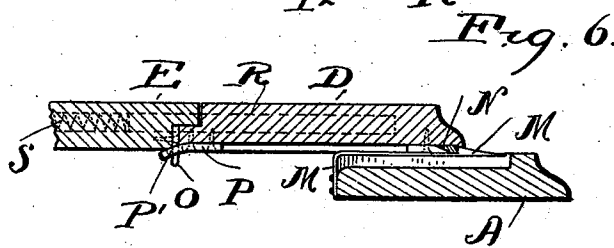
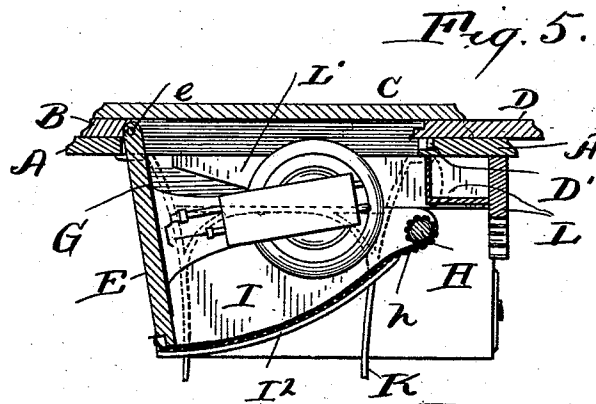
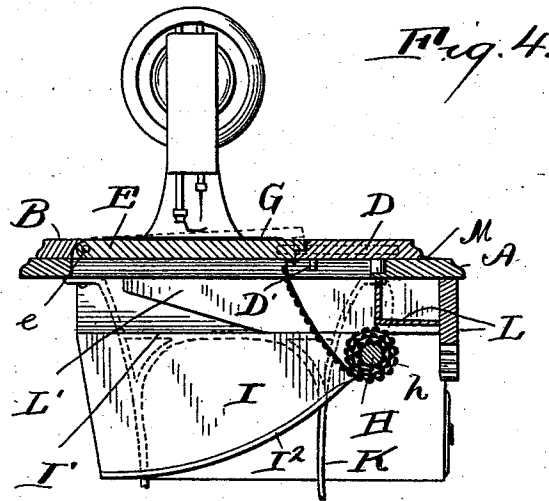

Witnesses.
E. B. Gilchrist
Charles

Inventor.
Theodor Kundtz
By Suggitt Suggitt
his attorneys.

UNITED STATES PATENT OFFICE.

THEODOR KUNDTZ, OF CLEVELAND, OHIO.

SEWING-MACHINE CABINET.

SPECIFICATION forming part of Letters Patent No. 524,090, dated August 7, 1894.

Application filed March 6, 1894. Serial No. 502,513. (No model.)

To all whom it may concern:

Be it known that I, THEODOR KUNDTZ, of Cleveland, in the county of Cuyahoga and State of Ohio, have invented certain new and useful Improvements in Sewing-Machine Cabinets; and I do hereby declare the following to be a full, clear, and exact description of the invention, such as will enable others skilled in the art to which it pertains to make and use the same.

My invention relates to improvements in sewing-machine cabinets, wherein the carrier that bears the sewing-machine-head is capable of being tilted below the table of the cabinet; and the invention consists in certain features of construction and in combinations of parts hereinafter described and pointed out in the claims.

In the accompanying drawings, Figure 1 is a top plan of a sewing-machine cabinet embodying my invention, showing the sewing-machine head in its elevated or operative position and having portions broken away and in section to reduce the size of the figure, and to more clearly show the construction. Fig. 2 is a front side elevation of the cabinet, showing a position of the moving parts corresponding to the position of the corresponding parts in Fig. 1. Fig. 3 is a front side elevation of the cabinet, showing the sewing-machine-head carrier tilted in its position below the table of the cabinet, and the roller-curtain that protects the sewing-machine head from dust and dirt from below the table of the cabinet. Fig. 4 is a vertical section on line 4—4, Fig. 1, looking in the direction of the arrow. Fig. 5 is a vertical section on line 5—5, Fig. 3, looking in the direction of the arrow. Fig. 6 is an enlarged vertical section on line 6—6, Fig. 1.

Referring to the drawings, A, B, C, and D designate the parts that form the table of the sewing-machine cabinet, part B resting upon and rigidly secured to part A and carrying the sewing-machine-head carrier E, that, at or near its rear edge is pivotally secured, as at e, to part B of the table in such a manner as to be capable of tilting below said table, said carrier, in its normal position, having its top surface flush with the upper surface of part B, as shown in Fig. 4, and having the

base-plate of the sewing-machine-head G secured thereto in any approved manner. The arrangement of parts is such that when the sewing-machine-head carrier is in its downwardly-tilted position the sewing-machine-head shall be entirely below the upper surface of part B of the table of the cabinet, so that part C, that is hinged, as at C', to part B in the usual manner, can be folded onto part B to thereby close the opening left in part B by the lowering or dropping of the sewing-machine-head and its carrier below part B, as hereinbefore described, part C being shown in position closing the opening referred to in Fig. 3.

One feature of my invention,—one of vast importance,—consists in the provision of a curtain-roller and curtain below the table of the cabinet for closing, at the front and bottom, the space occupied by the sewing-machine-head when the latter is in its downwardly-tilted position, and in suitably closing said space at the ends of the sewing-machine-head, so that when the sewing-machine-head is in its lowered position with the base of the head and its carrier closing the aforesaid space at the rear and with hinged leaf C closing the opening left in part B, the head shall be completely protected from dust and dirt, &c. The curtain-roller H is of the well known spring-actuated variety, the same being provided, at one end, with a spring H' acting to wind up the curtain.

Roller H is supported at opposite ends, by and at or near the upper and forward extremities of end-pieces I I that are rigid with the supporting-frame or legs K of the cabinet and adapted to close the ends of the space occupied by the sewing-machine when the latter is in its lowered position shown in Figs. 3 and 5, the upper portion of said space, above roller H, being closed by a drawer L that has rearward-extending guides or members L' adapted to slide upon ways I' formed upon parts I.

The curtain h that is suitably secured to and adapted to wind upon and unwind from roller H is suitably attached, at its opposite end, to the sewing-machine-head carrier, the curtain being preferably attached at or near the forward edge of said carrier, and the cur-

tain-roller is preferably supported as near the front and under side of the table of the cabinet as is practicable.

The construction of spring-actuated rollers is so well known that it is not considered necessary to illustrate or describe the same in detail. Suffice it to state that the roller-curtain is of sufficient length to accommodate the tilting of the sewing-machine-head and its carrier below the table of the cabinet, as hereinbefore described, and when said head or carrier is thus tilted downwardly, as shown in Figs. 3 and 5, it will be observed that the curtain will close at the front and bottom, the space occupied by the sewing-machine-head in its downwardly-tilted or lowered position. Hence, it will be observed, that, by my improved construction, the sewing-machine-head is adequately protected against dust, dirt, &c., when the head is in its lowered position, the space occupied by the same, in said position, being closed, at the ends by members I I,—at the front side by drawer L and roller-curtain *h*,—at the bottom by the roller-curtain, and, at the rear by the base of the head and its carrier. I would also remark that members I I are preferably provided with laterally and inwardly-projecting flanges I', the arrangement and trend whereof are such that the roller-curtain, in the drawn position of the latter, shall rest upon said flanges, as shown in Figs. 3 and 5.

Another feature of my invention consists in the provision of simple and efficient means for locking the carrier in its elevated position, which means can be conveniently operated by an adult, but cannot be easily operated by a child, and is not liable to be actuated by accident.

The sewing-machine-head-carrier, in its elevated position, is flush with part D of the table of the cabinet. Said part D and the carrier are preferably rabbeted at their meeting edges in such a manner that the rabbeted portion of the carrier shall rest upon the rabbeted portion of part D, (see Fig. 6) which construction, it is obvious, requires part D of the table to be movable forwardly in order to accommodate the downward tilting or lowering of the carrier. Part D of the table is, therefore, made movable in the direction indicated, the same being adapted to reciprocate forwardly and rearward upon stationary part A of the table. The sliding-part D is held in the position wherein it supports the forward portion of the carrier by means of a spring-latch or catch M that is adapted to engage the forward edge of a plate N suitably secured to the forward portion of the under side of sliding-member D of the table of the cabinet. Said catch or latch extends rearward in under part D and is shown suitably secured at its rear end, to stationary part A of the table.

Sliding-member D of the table and the carrier are preferably locked to each other in the elevated position of the carrier and the means employed for locking said parts together con-

sists, preferably, in a latch O that is suitably secured, preferably, to the forward edge of the carrier and is adapted to engage a hole, 70 P', in a latch-plate P that is suitably secured to the under side of member D. The arrangement of parts is such that in order to tilt the carrier downwardly as required to lower the sewing-machine-head below the table of the 75 cabinet the carrier must first be tilted upwardly to disengage latch O from latch-plate P, before sliding-part D of the table can be actuated forwardly.

Suitable means are provided for automati- 80 cally actuating part D in the direction indicated upon unlocking the carrier from said movable part of the table and upon unlocking said movable member of the table from the stationary part A. The means employed for 85 the purpose indicated consists preferably of two bars R R arranged at or near opposite ends of part D, respectively, said bars being rigid with member D and engaging corresponding holes in the stationary part B, and 90 springs S are confined within said holes between the rear end of bars R and the inner or rear ends of the holes, said springs acting in the direction to push bars R and part D forwardly. Hence, it will be observed that 95 upon unlocking the carrier from part D and unlocking said member D from part A, part D will be pushed forwardly automatically by the action of the aforesaid springs, permitting the sewing-machine-head and its carrier 100 to be lowered as hereinbefore described. Suitable means are also provided for arresting the forward movement of part D, that is, for limiting the forward movement of said part to prevent a disengagement of bars R 105 from the holes in part B, and the means employed for the purpose consists preferably of one or more depending lugs or members D' rigid with part D and adapted to engage the rear edge of stationary part A, with the arrangement of parts such that said lugs or de- 110 pending members shall come into engagement with part A before bars R have become disengaged from the holes in part B.

What I claim is—

1. In a sewing-machine-cabinet, a horizontally-sliding-part D at the forward side of the table, a stationary part A upon which said part D slides, a stationary part B rearward of said sliding-part, sewing-machine-head-carrier supported from part B in such a manner as to be capable of tilting downwardly, suitable means for locking said carrier, in its elevated position, to movable part D, suitable means for locking said movable part D, in its rearward position, to part A, and suitable means for automatically pushing said movable part forwardly upon unlocking the carrier from said movable part and unlocking said movable part from the stationary part 130 upon which it slides, substantially as set forth.

2. In a sewing-machine-cabinet, a table comprising a horizontally forwardly and rearwardly-sliding part D, a stationary part B

rearward of said sliding part, a stationary part A supporting said sliding part, sewing-machine-head-carrier pivotally supported from part B in such a manner as to be capable of tilting downwardly, the upper surface of the carrier, in its elevated or horizontal position, being flush with the upper surface of said sliding-part, and said carrier and sliding-part being rabbeted at their adjacent edges in such a manner that the rabbeted portion of the carrier is adapted to rest upon the rabbeted portion of the sliding-member of the table, suitable means for locking said sliding-member in engagement with the carrier and suitable means for automatically pushing said sliding-member out of engagement with the carrier upon unlocking the sliding-member, substantially as set forth.

3. In a sewing-machine-cabinet, a table comprising stationary members A and B arranged, the latter above the former, and a sliding-member D capable of sliding forwardly and rearward upon member A forwardly of member B, a downwardly-tilting

sewing-machine-head-carrier supported by member B, the aforesaid sliding-member being provided with rearward-extending bars R and a stationary part D having holes for receiving said bars and springs confined within said holes between the free ends of the bars and the inner ends of the holes and adapted to act in the direction to push the aforesaid sliding-member forwardly, said sliding-member extending in under the carrier and suitable means for holding said sliding-member in position supporting the forward portion of the carrier, and suitable means for locking said sliding-member, in the carrier-supporting position, to the supporting-member, the arrangement of parts being substantially as and for the purpose set forth.

In testimony whereof I sign this specification, in the presence of two witnesses, this 30th day of January, 1894.

THEODOR KUNDTZ.

Witnesses:

C. H. DORER,
WARD HOOVER.