



- (21) Application No. 52374/76 (22) Filed 15 Dec. 1976 (19)
- (31) Convention Application No. 7 514 805 (32) Filed 18 Dec. 1975 in
- (33) Netherlands (NL)
- (44) Complete Specification published 25 June 1980
- (51) INT. CL.³ E04G 21/12 11/06
- (52) Index at acceptance
E1L 4A5B 4A6A 4A6D 4K
- (72) Inventor JAN PIETER BRAMSEN

(54) METHOD AND SLIP FORM FOR THE ERECTION OF AN ANNULAR CONCRETE BUILDING

(71) We, BALLAST-NEDAM GROEP N.V., of No 2, Laan van Kronenburg, Amstelveen, the Netherlands, a Body Corporate organised and existing under the Laws of the Netherlands, do hereby declare the invention, for which we pray that a patent may be granted to us, and the method by which it is to be performed, to be particularly described in and by the following statement:-

The invention relates to a method of erecting a building having an upright, annular wall of reinforced post-tensioned concrete, which wall comprises post-tensioning wires located between upright reinforcing inner rods and upright reinforcing outer rods and surrounded by sheaths and is manufactured with the aid of a slip form comprising an inner casing, an outer casing and a plurality of brackets distributed along the circumference of the wall and interconnecting the inner and outer casings.

In a known form of such a method the manufacture of the wall is periodically interrupted for a long interval in order to adjust the reinforcement.

The invention has for its object to reduce the time interval required for adjusting the reinforcement.

In accordance with the invention there is provided a method of erecting a building having a vertical, annular wall of reinforced, post-tensioned concrete, said wall comprising post-tensioning wires extending horizontally between vertical reinforcing inner rods and outer rods and surrounded by sheaths and being made with the aid of a slip form comprising an inner casing and an outer casing and a plurality of brackets distributed along the circumference of the wall and interconnecting the inner casing and the outer casing, wherein a bundle of sheaths of horizontal post-tensioning wires is handled in the following sequence of steps:

- a. a bundle of sheaths is suspended from the brackets,
- b. the bundle is enclosed between vertical reinforcing inner rods and outer rods, and

c. sheaths are successively taken from the bundle and set in place according as the outer casing approaches the places for the post-tensioning wires.

A further reduction of the interval is obtained, if first a supply of sheath is arranged outside the sliding casing, but inside the brackets.

The invention provides, in addition, an improvement in a slip form for carrying out a method in accordance with the invention, said slip form comprising an inner casing an outer casing and a plurality of brackets interconnecting the inner casing and the outer casing, and means for temporarily suspending a bunch of sheaths from the brackets, said means being provided and connected to said brackets in an area between vertical slip casing planes of the outer and inner casing.

The invention furthermore relates to a building structure erected by carrying out the method embodying the invention.

The invention will now be described by way of example with reference to the accompanying drawings, in which:-

Figure 1 is a perspective view of a building embodying the invention.

Figure 2 is an enlarged sectional view taken on the line II-II in Figure 1,

Figure 3 is an enlarged sectional view taken on the line III-III in Figure 1 during the post-tensioning operation on the concrete,

Figure 4 is an enlarged, perspective view of the detail IV of Figure 1 in the direction of the arrow A during the erection of the building,

Figure 5 is a sectional view taken on the line V-V in Figure 4,

Figures 6 and 7 illustrate on an enlarged scale the detail VI of Figure 5 in successive steps, and

Figure 8 shows on an enlarged scale detail VIII of Figure 3.

The building 1 shown in Figure 1 which may be a reservoir for a liquid, for example, water comprises a horizontal base plate 3

and a standing, annular wall 2 of reinforced post tensioned concrete. The wall 2 comprises, embedded in the concrete 4, reinforcing outer meshes 5 interconnected by rods 11 and comprising horizontal rods 7 and vertical rods 8 and reinforcing inner meshes 6 comprising horizontal rods 9 and vertical rods 10 interconnected by rods 12. Between these elements the wall 2 comprises vertical climbing rods 23 and post tensioning wires 14 surrounded by sheaths 13, which extend along the whole circumference of the wall 2 to the two sides 15 of a vertical tensioning rib 16. The wall 2 is made by means of a slip form 17 mainly comprising a horizontal, annular inner casing 18 and a horizontal, annular outer casing 19 and a plurality of brackets 20 distributed along the circumference of the wall 2 and interconnecting the inner casing 18 and the outer casing 19. The inner casing 18 has an internal platform 21, and the outer casing 19 has an external platform 22. The brackets 20 are each connected by a climbing mechanism 24 of known type to a respective climbing rod 23. The invention is intended to allow the slip form 17 to ascend a minimum of interruption, whilst constantly concrete is introduced by people standing on the internal platform 21 and the prescribed reinforcement is constantly set up by people mainly standing on the external platform 22. During the rise of the slip form 17 the sheaths 13 are first—preferably continuously—inserted inside the brackets 20, where they are guided inside three rollers 25 journalled on each bracket 20, after which they are stored outside the outer casing 19 on supports 26 (see Figures 6 and 7). In the meantime the external reinforcing meshes 5 can be spaced apart at such a distance g that the brackets 20 can pass in between. The sheaths 13, already containing the post-tensioning wires 14 in this embodiment, are arranged in accordance with the invention by the following sequence of steps:

Step *a*: a bundle 28 of sheaths 13 is temporarily suspended inside the brackets 20 by pins 30 on a web 27 of each bracket 20, in groups of three by means of wires 29.

Step *b*: the bundle 28 is enclosed between vertical reinforcing inner rods 8 and vertical reinforcing outer rods 10, since in step *b* the reinforcing inner meshes 6 (see Figure 6, broken lines and Figure 7, solid lines) are set in position, and

Step *c*: sheaths 13 are taken from the bundle 28 and set at their places by means of wires 31 on the inner side of the reinforcing outer meshes 5 according as the outer casing 19 approaches the positions of the post-tensioning wires 14 (cf. Figures 6 and 7).

During step *a* the sheaths 13 can be readily suspended from the supports 26 three by three. The wires 29 and the pins 30 constitute suspension means for temporarily suspending

the sheaths 13 from the brackets 20 (see Figure 6).

During step *c* adjacent reinforcing meshes 5 or 6 are inter-connected by means of the rods 11 and 12 respectively arranged beneath the passed web 27 of each bracket 20.

The slip form 17 is characterized by rib casing means 32 for the formation of a vertical concrete tensioning rib 16 on the wall 2, said means being mainly formed by a panel 33 extending beyond the outer casing 19 and sliding upwardly with the casing and by two vertical, stationary casing elements at the sides thereof, for example, partitions 34 having recesses 35 for passing post-tensioning wires 14 held in the sheaths 13. During the setting of each sheath 13, its two ends 36 are anchored in the partitions 34 by means of braces 40.

Reinforcing meshes 37, arranged in the tensioning rib 16, have bracket-shaped, horizontal rods 38.

After the concrete 4 has cured, the post-tensioning wires 14 are tensioned by means of tensioners 39 of known type, whose clamping jaws 41 urged radially inwardly by hydraulic cylinders 42 grip the ends 36 of the wires 14. A hydraulic cylinder 43 of each tensioner 39 provides the required tensile force, whilst the piston 44 of said cylinder 43 bears by rods 45 on the tensioning rib 16. When the required tensile force K is attained, a bipartite cone 46 is hammered into each brace 40, after which each tensioner 39 is removed.

WHAT WE CLAIM IS:—

1. A method of erecting a building having a vertical, annular wall of reinforced, post-tensioned concrete, said wall comprising post-tensioning wires extending horizontally between vertical reinforcing inner rods and outer rods and surrounded by sheaths and being made with the aid of a slip form comprising an inner casing and an outer casing and a plurality of brackets distributed along the circumference of the wall and inter-connecting the inner casing and the outer casing, wherein bundle of sheaths of horizontal part-tensioning wires is handled in the following sequence of steps:

a. a bundle of sheaths is suspended from the brackets,

b. the bundle is enclosed between vertical reinforcing inner rods and outer rods, and

c. sheaths are successively taken from the bundle and set in place according as the outer casing approaches the places for the post-tensioning wires.

2. A method as claimed in claim 1, wherein a supply of sheaths is first built up outside the sliding casing but within the brackets.

3. A method as claimed in claim 1 or 2, wherein during the setting-in-place operation for each sheath its two ends are anchored in stationary casing elements.

4. A slip form for carrying out the method claimed in claim 1 2 or 3, comprising an inner casing, an outer casing and a plurality of brackets interconnecting the inner casing and the outer casing, and means for temporarily suspending a bunch of sheaths from the brackets, said means being provided and connected to said brackets in an area between vertical slip casing planes of the outer and inner casing.
5. A slip form according to claim 4, comprising an inner casing, an outer casing, a plurality of brackets interconnecting the inner casing and the outer casing and rib casing means for the formation of a vertical concrete abutment rib on the wall.
6. A slip form as claimed in claim 5, wherein the rib casing means comprise a panel extending beyond the outer casing and sliding upwardly with the casing and two stationary partitions on either side thereof and having recesses for the passage of post-tensioning wires contained in the sheaths.
7. A building erected by carrying out the method claimed in claim 1, 2 or 3.
8. A method of erecting a building, substantially as hereinbefore described with reference to and as illustrated in the accompanying drawings.
9. A slip form substantially as hereinbefore described with reference to and as illustrated in the accompanying drawing.
10. A building, substantially as hereinbefore described with reference to and as illustrated in the accompanying drawings.

REDDIE & GROSE,
16 Theobalds Road,
London WC1X 8PL.
Agents for the Applicants,

FIG.1

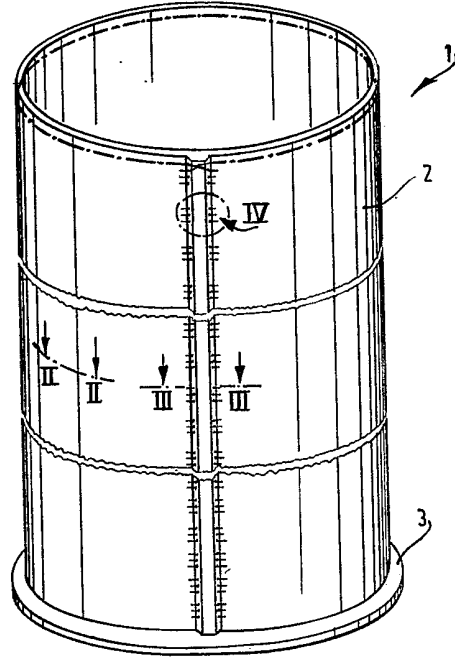

FIG. 2

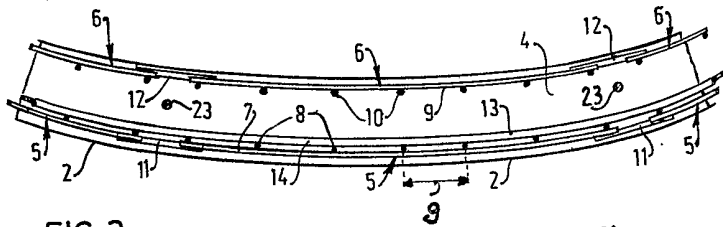
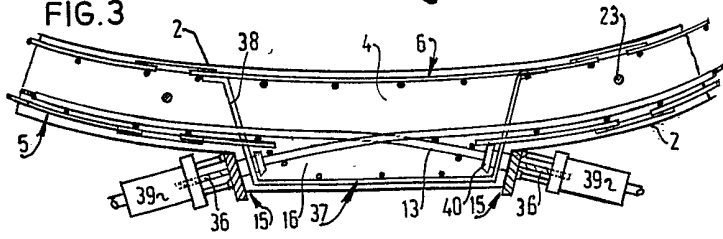

FIG. 3



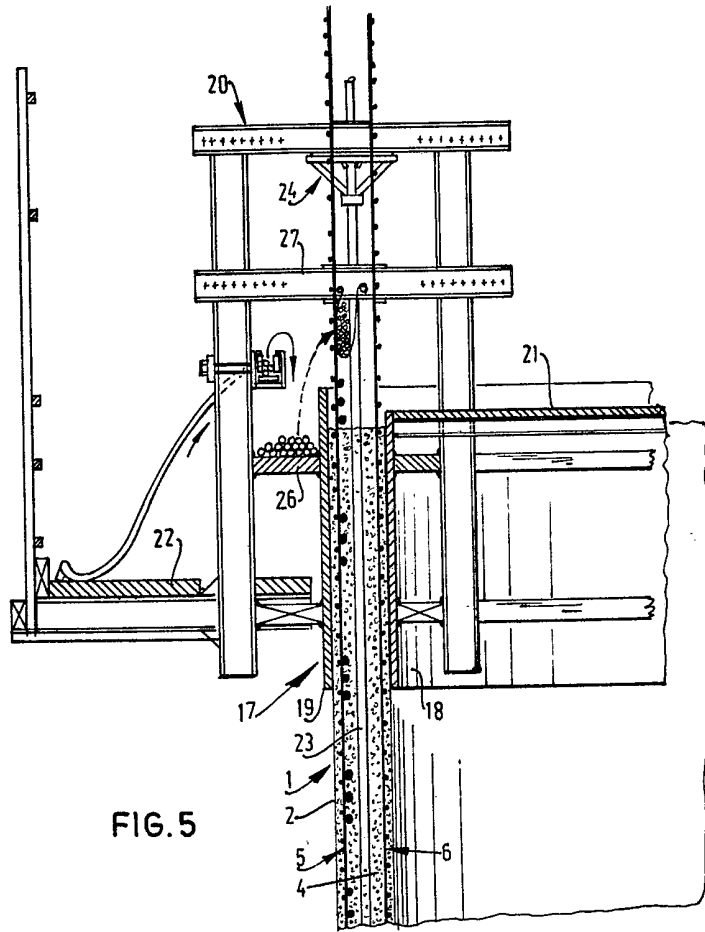

FIG. 5

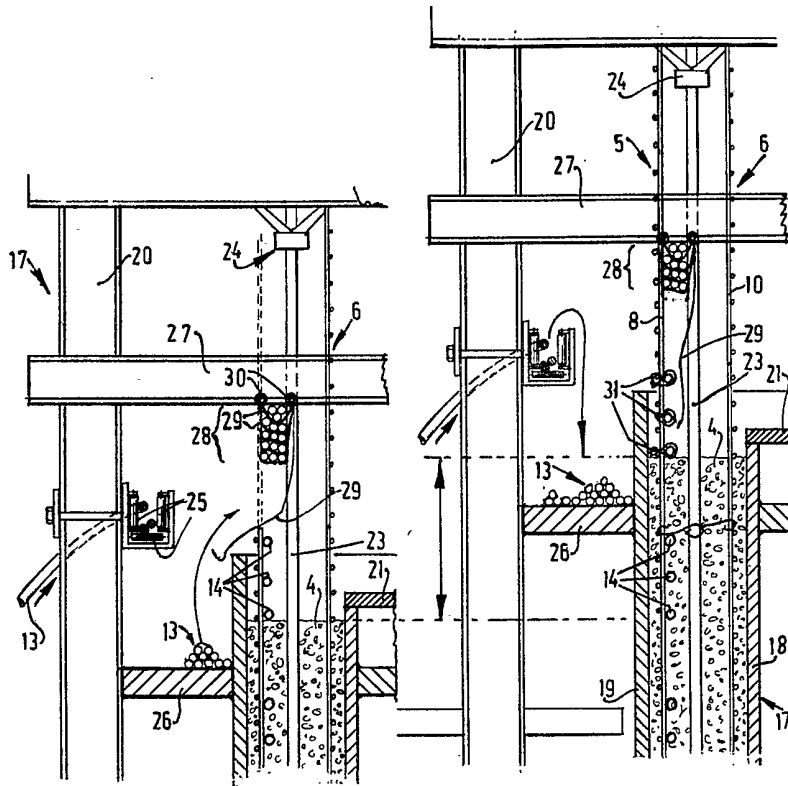

FIG. 6

FIG. 7