

(19)  
(12)

(KR)  
(A)

(51) 。 Int. Cl. 7  
H04N 5/913

(11)  
(43)

2003-0043133  
2003 06 02

(21) 10-2001-0074151

(22) 2001 11 27

(71) 가 161

(72) 383-2 2-203

103-1105

406-1504

103-102

(74)

:

(54) /

가 / DC  
(Human Visual Characteristic)

가

가

가

3

, , DC , ,

- 1
- 2
- 3
- 4
- 5
- 6
- 7
- 8
- 9

ok, 가 TV, Image, Video, MP3 가 E-Bo

가 가 , 가 가 MP3

가 , 가 , 가 , 가

DCT

Cox DCT(Discrete Cosine Transform) DCT

(Human Visual System) JND(Just Noticeable Difference) DC

JND DCT DC

가 , DCT

DCT

가 , ,  
DCT DCT , ,  
JPEG2000 JPEG2000 .  
가 , , , 가 DC  
, 가 JPEG ,  
가 . , 가  
, , .  
2001 'ISIE 2001, Pusan, Korea' 1946 1950  
'A blind watermarking technique using wavelet transform'  
'A blind watermarking technique using wavelet transform'  
, 가 /  
, 가 , 1/10  
, .  
, DC , DC  
가 / ,  
, , /  
, ; 가 ;  
; 가 ;  
, ; ; 가  
가 ; 가 ;  
; ;  
, ;  
(a) ; (b) ;  
; (c) 가  
; (d) ;  
, (a') ; (b') 가 ;  
; ;

(c')

; (d')

;

1

1

1 (a)

1 (b)

DC 가

DC 가

가

1 (b)

M×N

LL<sub>n</sub>

$$size(LL_n) = \frac{M}{2^n} \times \frac{N}{2^n}$$

1 (b)

LL<sub>n</sub>

가

LL<sub>n</sub>

(Detail)

DC

(Estimate)

가

DC

(Human Visual Characteristic)

DC

가

2  
ts)

2 LL<sub>n</sub>

(RHFC: Removing High Frequency Componen

LL<sub>n</sub>

2 (200)

(S10).

DC  
DC

LL<sub>n+1</sub>  
LL<sub>n+1</sub>

LH<sub>n+1</sub>, HL<sub>n+1</sub>, HH<sub>n+1</sub>

1  
LL<sub>n</sub>

(200)  
LL<sub>n</sub>'

(S12).

3

3

(LL)

(300)

(302)

(LL) DC

1

, '0'

1

(LL')  
 (LL') (304) 가 (308) (LL) (304) (Key2) ,  
 가 (Key1) 가 (w(i)) (idx(i)) (306) (idx(i))  
 , '0' '1' 가  
 (w(i)) '1' '-1' , '1' , 가 ,  
 (304) (idx(i)) (LL)  
 4 (304)  
 4 (304) (304)  
 (304) 4 (S400) (LL) (LL) , (S402)  
 (302) (idx(i)) (308) (w(i)) (306) (LL')  
 (w(i)) '1' i '1' (304) (S408) (S406)  
 (304) (S410) (LL(idx(i))) (LL') (w(i)) '1' (LL  
 ) (INTERVAL) 가 (LL(idx(i))) (LL') (LL'(idx(i))) 가  
 i))) (LL) (LL') (LL') (LL'(idx(i))) (LL'(idx(  
 가 가 ,  
 (LL(idx(i))) (LL'(idx(i))) 가  
 (304) (S418) (LL(idx(i))) 가  
 (LL'(idx(i))) (LL) (304)  
 (S412) (LL(idx(i))) 가 (LL'(idx(i)))  
 (LL(idx(i))) (LL'(idx(i)))  
 4) (S408) (w(i)) '0' (LL) (304) (S41  
 (LL(idx(i))) (LL') (LL'(idx(i)))  
 (LL) (LL'(idx(i))) (LL(idx(i)))  
 (LL') (LL) (LL') (LL'(idx(i)))  
 (S418) (304) (LL) (LL)  
 (LL(idx(i))) (LL')

(LL) (LL(idx(i))) (LL') (LL'(idx(i)))  
 (304) (S416) (LL) (LL(idx(i))) (LL') (L  
 L') (LL'(idx(i))) (LL(idx(i))) (LL')

가 (LL) (LL')

가 , 가

(304) (S418) (w(i)) i  
 (WM\_LEN) (w(i)) i , (w(i)) i (w(i))  
 (S408) (S418) (304) (S418) (S420) , i '1' 가 ,  
 (w(i)) i (304) (S418) (S420) , (w(i))  
 (LL E) (w(i))

, 4 (LL E) 4

(LL) , (LL')  
 (LL E) (300) (304) (LL)

5 , 5 10  
 (Iteration) 가 가

6 ,  
 6 가

(Original Image)(600) (S50).  
 (600) 가 (LL)

(300) 가 (S52). (LL)

(LL') (300) 가 (LL)  
 가 (Key2) (Key1)  
 (idx(i)) (w(i))  
 (S54). (LL) (w(i))  
 (LL') 가 '1' (LL) 가  
 (LL') 가 '-1' (LL)

가 가 (LL E) (602) (S56)  
 (WM Embedded Image)(604)

)) , (Key2) (idx(i) (Key2))  
 (idx(i))  
 7 7  
 (LL E) 가 (idx(i))가  
 (idx(i)) (Key2)  
 L E) (700) (LL E') (702) (L  
 (Key2) (LL E) (LL E)  
 (idx(i)) (LL E')  
 (w\_E(i)) (708) 가 (710)  
 (Key1) (w(i)) 가  
 (w(i)) [ 2] (w\_E(i)) (Correlation)  
 (Normalized Similarity: NS) 가

$$Sim(w, w_E) = \frac{\sum_{i=1}^{WM\_Length} w(i) \cdot w_E(i)}{\sum_{i=1}^{WM\_Length} w_E(i) \cdot w_E(i)}$$

(Similarity) 가 '0'  
 가 가  
 8 8 (704)  
 (704) 8 (S800) 가 (LL E)  
 (702) (idx(i)) (LL E') (S802), (S804)  
 y1) (idx(i)) (706) (w(i)) (710) (w(i)) (Ke  
 '1' 가 i '1' (708) (S806)  
 (LL E') 가 (LL E) (S808) (LL E)  
 (704) (S810) 가 (LL E') 가 '1'  
 (LL E) (704) 가 (S808) (S812) (LL E')  
 가 '-1'

(WM\_LEN) (704) (S814) i (w(i))  
 i ,  
 (S808) (S814) (704) (S814) (S816) (w E (i)) '1' 가 ,  
 (w E (i)) i (704) (S814) (S818)  
 9 9 가 가 ,  
 (S92). 가 (900) (700) (Key2)  
 (Key1) 가 (LL E) (w E (i)) (w(i)) (S94).  
 가 (Key2) (Key)  
 , 가 DC  
 가 , ,  
 DC , 가 가  
 , 가 가  
 가 .  
 가 ;  
 ; 가 ;  
 가 ;

(57)

1.



1    2.    ,    ,    ,    1    ,    ,    1

2    3.    ,    ,    1    ,    ,    '0'

1    4.    ,    ,    ,    (Key2)    가

1    5.    ,    ,    ,    DC    ,

1    6.    ,    ,    ,    (Key1)    ,    '1'    '-1'

1    7.    ,    ,    ,    가    '1'

7    8.    ,    ,    ,    가 '1'  
(INTERVAL) 가

[    ]

LL<sub>E</sub> (idx(i))=LL'(idx(i))+INTERVAL

idx(i):

LL':

LL<sub>E</sub> : DC

1 9. ,  
가 '-1'  
가

9 10. ,  
가 '-1'  
(INTERVAL)

[ ]

LL<sub>E</sub> (idx(i))=LL'(idx(i))-INTERVAL

idx(i):

LL':

LL<sub>E</sub> : DC

8 11. 10 ,  
(INTERVAL) ,

12.

;

;

;

가

가

;

12 13.

12 , , 1 , 1

12 14.

, 1

'0'

12 15.

(Key2)

가

12 16.

DC

16 17.

(Key1)

'1' '-1'

12 18.

18 19.

'-1'

'1'

12 20.

(w<sub>E</sub>(i))

(w(i))

20 21.

가 , 가 ,  
가 .

[      ]

$$Sim(w, w_E) = \frac{\sum_{i=1}^{WM\_Length} w(i) \cdot w_E(i)}{\sum_{i=1}^{WM\_Length} w_E(i) \cdot w_E(i)}$$

WM\_Length:

w(i):

w<sub>E</sub>(i):

**22.**

- (a) ;
- (b) ;
- (c) 가 ;
- (d) ;

**23.**

22

- (a) , DC ;

**24.**

22

- (a) , (Key2)

**25.**

22

- (d) , (d1) ;
- (d2) '1' 가 ;
- (d3) '-1' 가 ;

**26.**

25 ,  
 (d2) , '1'  
 (INTERVAL) 가

[ ]

$LL_E(idx(i)) = LL'(idx(i)) - INTERVAL$

idx(i):

LL':

LL<sub>E</sub> : DC

**27.**

25 ,  
 (d3) , '-1'  
 (INTERVAL)

[ ]

$LL_E(idx(i)) = LL'(idx(i)) - INTERVAL$

idx(i):

LL':

LL<sub>E</sub> : DC

**28.**

25 27 ,  
 (INTERVAL) ,

**29.**

22 ,  
 , (Key1) '1' '-1'

**30.**

22 ,  
 , DC ,

**31.**

- (a) ; 가
- (b) 가 ;
- (c) ;
- (d) ;

**32.**

- 31 ,
- (a) , DC ,

**33.**

- 31 ,
- (c) , (c'1) ;
- (c'2) ;

**34.**

- 33 ,
- (c'2) , (c'21) '1' ;
- (c'22) '-1' ;

**35.**

- 31 ,
- (d) , 가 ,
- 가

[ ]

$$Sim(w_s, w_E) = \frac{\sum_{i=1}^{WM\_Length} w(i) \cdot w_E(i)}{\sum_{i=1}^{WM\_Length} w_E(i) \cdot w_E(i)}$$

WM\_Length:

w(i):

$w_E(i)$ :

31 36.

(Key1)

'1' '-1'

31 37.

DC

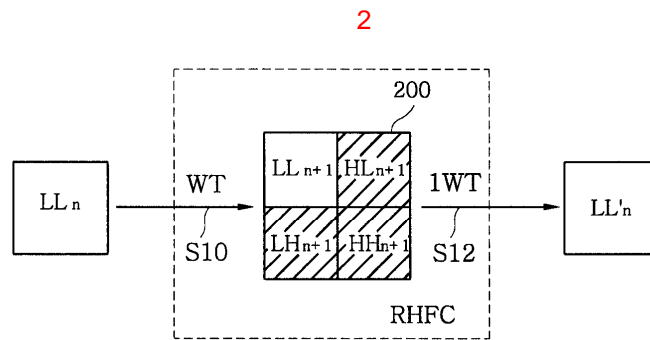
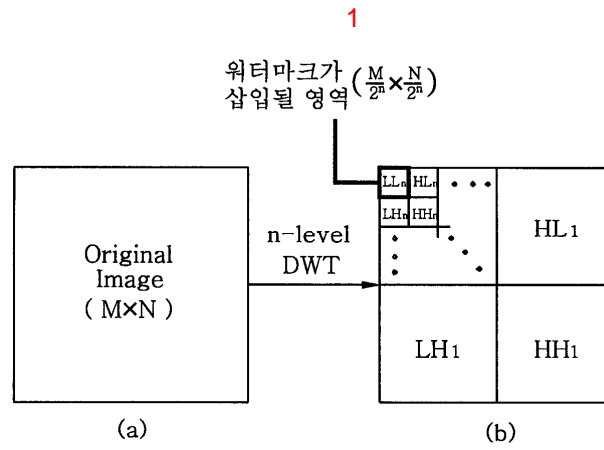

3

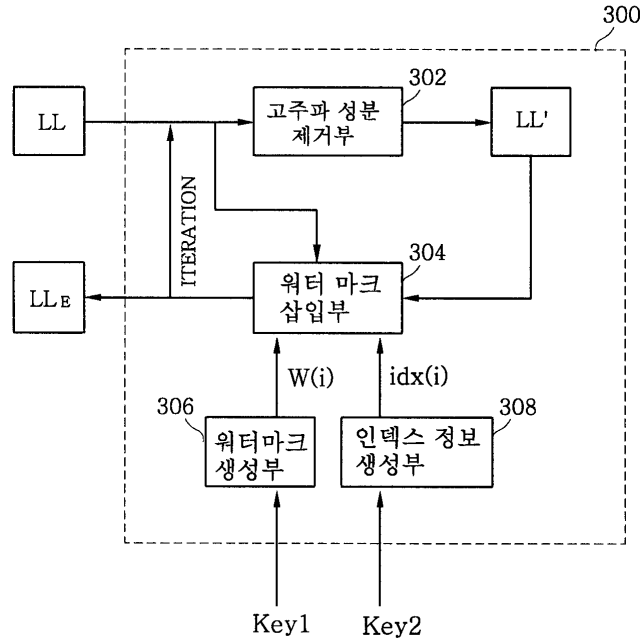

4

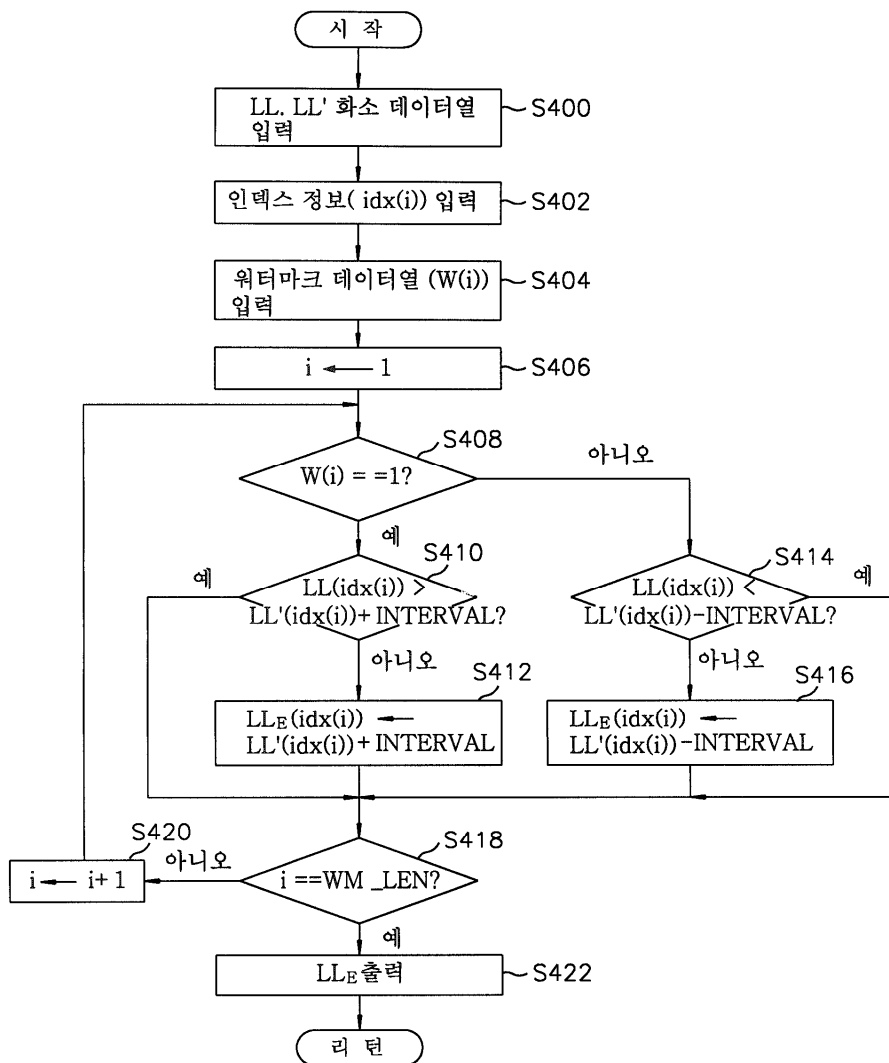



5

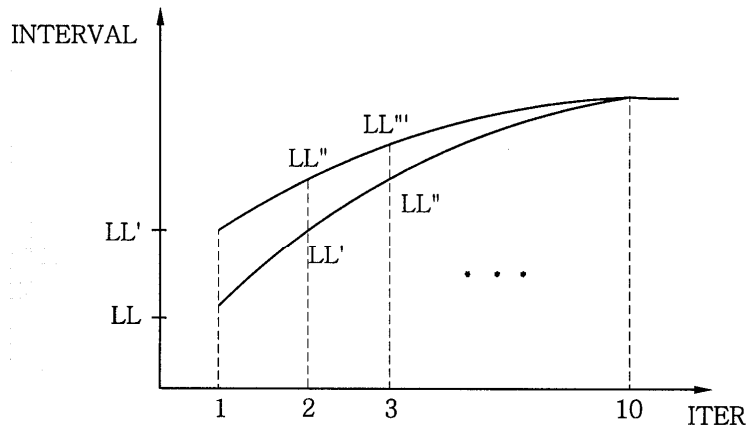

6

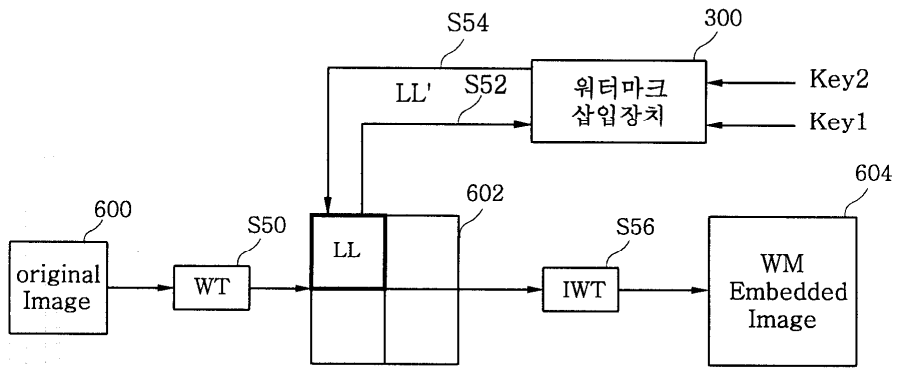

7

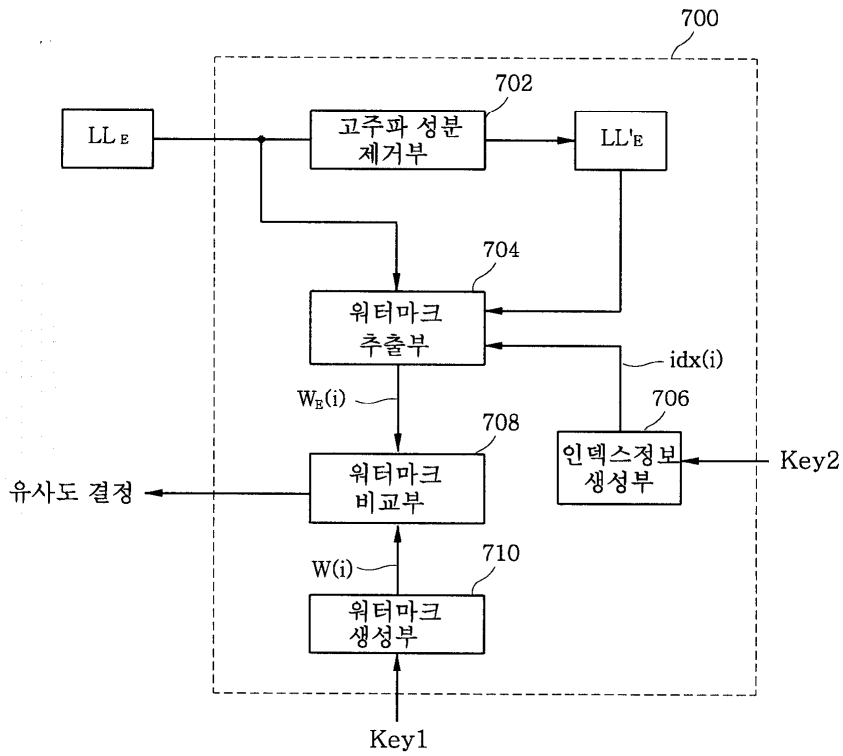

8

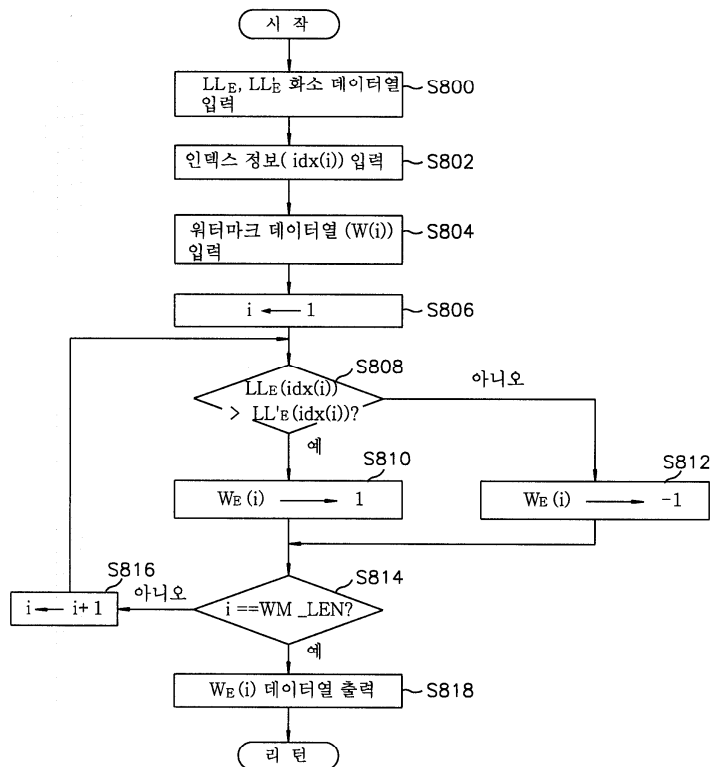

9

