

# Wheeler & Manley.

## Pounding Hats.

No 57232

Patented Aug. 14, 1866.

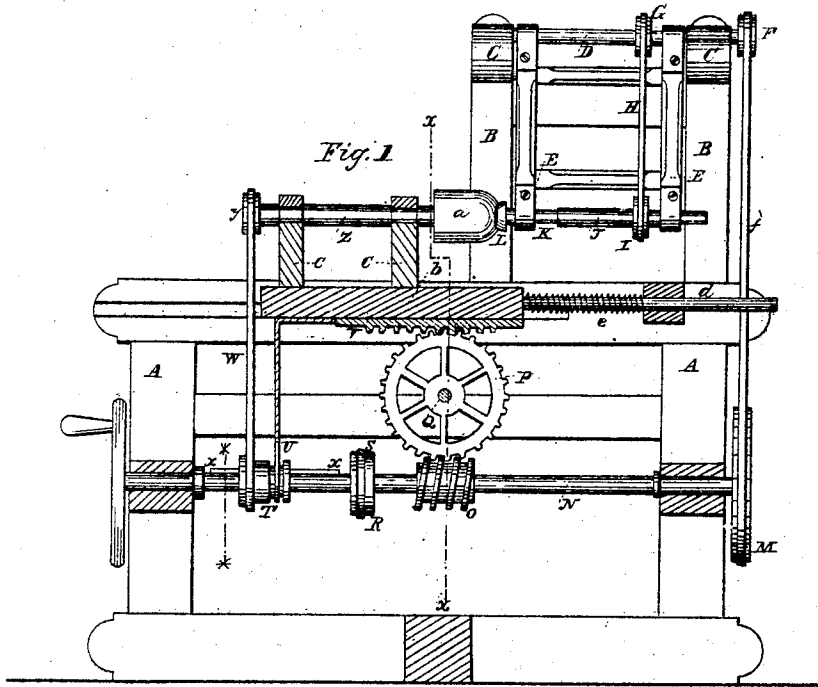

Fig. 1

Fig. 3

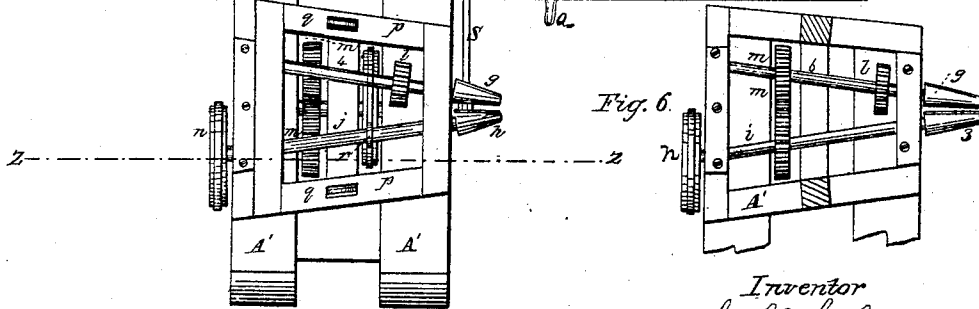
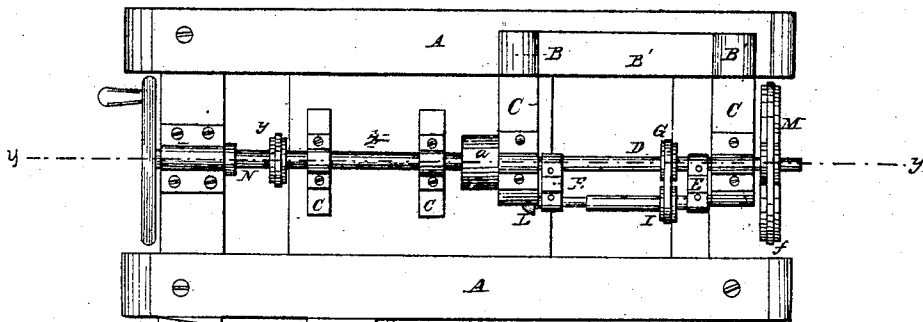

Fig. 6

Witnesses  
 Wm. Cheurn  
 Theo. Lusch

Inventor  
 S. S. Wheeler  
 D. B. Manley  
 By *[Signature]*  
 atty

# Wheeler & Manley.

## Pouncing Hats.

N<sup>o</sup> 57232

Patented Aug. 14, 1866.

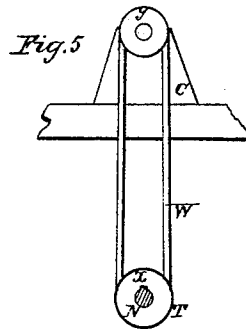
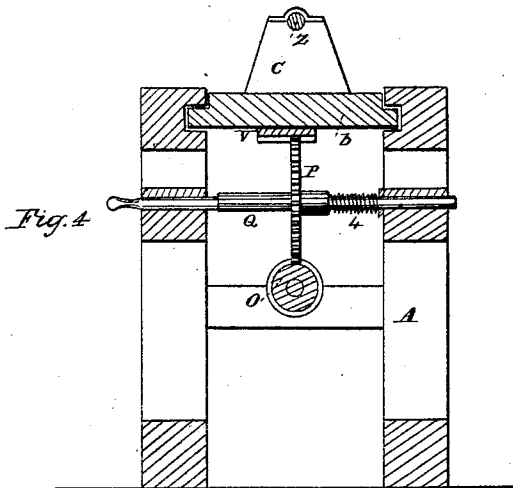
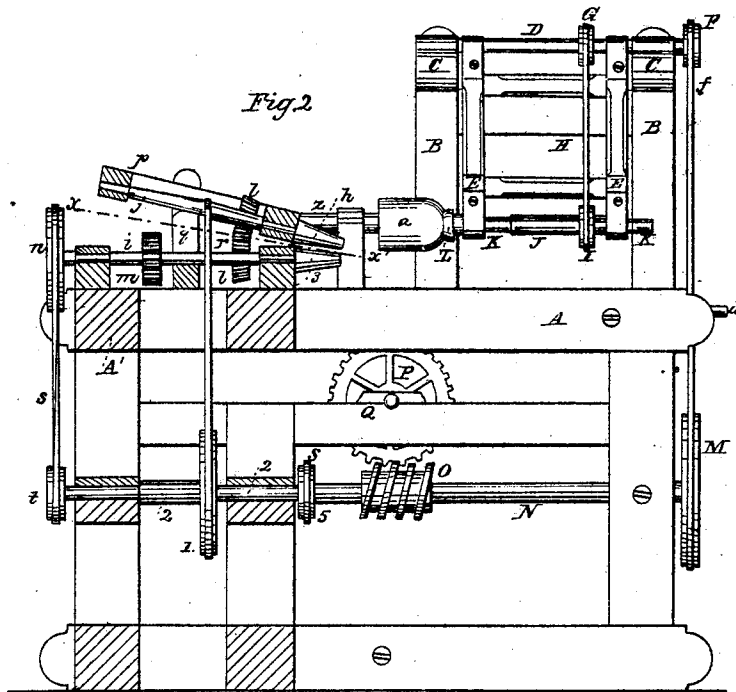

Witnesses  
 Wm. Breun  
 Theo. Luch

Inventor  
 J. S. Wheeler  
 D. B. Manley  
 By *Pythian*  
 Att<sup>y</sup>

# UNITED STATES PATENT OFFICE.

SIDNEY S. WHEELER AND DANIEL B. MANLEY, OF DANBURY, CONN.

## IMPROVEMENT IN MACHINES FOR POUNCING HATS.

Specification forming part of Letters Patent No. 57,232, dated August 14, 1866.

*To all whom it may concern:*

Be it known that we, S. S. WHEELER and DANIEL B. MANLEY, of Danbury, Fairfield county, Connecticut, have invented a new and useful Improvement in Machines for Pouncing Hat-Bodies; and we do hereby declare that the following is a full, clear, and exact description thereof, which will enable those skilled in the art to make and use the same, reference being had to the accompanying drawings, forming part of this specification, in which—

Figure 1 is an elevation of a vertical section of a machine made according to our invention, the plane of section being seen at *y*, Fig. 3. Fig. 2 is an elevation of the machine, part thereof being shown in section on the line *z*, Fig. 3. Fig. 3 is a plan. Fig. 4 is a cross-section on the line *x* of Fig. 1, looking toward the left. Fig. 5 shows a section of the main shaft *N*. Fig. 6 is a plan of frame *A'* without the upper vibrating frame, *p*.

Similar letters of reference indicate corresponding parts.

The object of this invention is the pouncing of hat-bodies by mechanical means; and it consists, among other things, in pouncing a hat-body by means of an emery-cylinder or other pouncing-surface moving at a high speed in contact with or against a hat-body revolving or otherwise moving at a comparatively low speed; also, in mounting the hat-block upon a carriage capable of being moved toward the emery-cylinder; also, in mounting the emery-cylinder upon a vibrating frame which is capable of swinging across the path of the hat-block carriage.

The letters *A A'* designate the frame of the machine, whose general shape, in plan view, is that of two parallelopipedons so joined as to form a right-angled figure. The part *A* of the frame carries a main driving-shaft, *N*, whose journals revolve in fixed bearings in the ends of that part of the frame. This shaft is driven by means of a crank or other suitable means at one of its ends, and at its other end has a pulley, *M*, from which a band, *f*, proceeds to a pulley, *F*, above.

The shaft *N*, at about the middle of its length, carries a worm, *O*, which engages the teeth of a cog-wheel, *P*, on a transverse shaft, *Q*, which is capable of an endwise movement in its bear-

ings, as indicated in Fig. 4, where the shaft *Q* is shown surrounded by a spiral spring, *4*, one end of which rests against the frame *A* and the other end against the hub of the wheel *P*. The shaft *Q* projects beyond the frame *A* on the left-hand side in Fig. 4, so as to be accessible to the operator, who, by pushing it inward, moves the wheel out of engagement with the worm *O*, and also beyond and out of engagement with a rack on the bottom of the sliding carriage *b*, whereby that carriage is free to move independent of said wheel. The carriage *b* slides in grooved ways formed for it in the sides of the top rails of frame *A*, and carries a horizontal spindle, *Z*, on one end of which is mounted a hat-block, *a*, of any desired form. The spindle has its bearings in the top of standards *c c*, that rise from the top of the carriage *b*, and it is rotated by means of a pulley, *y*, formed on the back end of the spindle, which pulley is driven by a band, *W*, from a sliding pulley, *T*, on the main shaft *N* below. The under surface of the carriage *b* has affixed to it a rack, *V*, with which the teeth of the cog-wheel *P* engage when the latter is in its normal position in the machine.

From the hinder end of the carriage *b* an arm, *U*, descends, whose lower end is forked to enable it to embrace a groove made for it on the inner or forward end of sliding pulley *T*. This pulley is placed loosely on the main shaft, but it is only allowed endwise motion thereon, rotary motion thereon being prevented by a feather, *x*, on the shaft, which enters a groove formed on the inner circumference of the pulley. The pulley, therefore, is compelled to revolve with the shaft *N*; but it is made also to move endwise thereon to and fro with the carriage *b* by means of the said forked arm *U*, whereby the pulleys *T* and *y* are kept in the same vertical plane whatever may be the position or the movements of the carriage *b*. From the forward end of the carriage *b* extends a rod, *d*, which passes freely through the cross-piece at the forward end of frame *A*, and carries on it, between said cross-piece and the end of the carriage, a spiral spring, *e*, whose action is to force the carriage backward, which it is free to do when the wheel *P* is moved laterally out of engagement with the rack *V* of the carriage.

B B are two standards which rise from the outer side of the frame at its forward end. They are properly strengthened by one or more cross-pieces, and from their tops brackets C C project horizontally over the frame A, for the purpose of furnishing bearings for the shaft D of a hanging frame, E, that carries an emery cylinder or wheel, L. That end of shaft D which is near the forward part of the frame A carries a pulley that is driven by a band, *f*, from the large pulley M of the main shaft N, and by this means the shaft D is revolved. Said shaft D also has a pulley, G, which is connected by a band, H, with a pulley, I, fixed on a horizontal spindle, J, which has bearings in the lower ends of the hanging frame E, so that the said spindle J is made to revolve so long as rotary motion is given to shaft D. Upon its inner end the spindle J carries a cylinder or wheel, L, which is covered with emery or its equivalent after any suitable manner. The spindle J is allowed to move endwise in its bearings, its diameter being reduced at K K so that it may slide a little way to and fro through its bearings when occasion requires.

The shaft N also carries a pulley, R, whose place is, in this example, behind the worm O. A band, S, from this pulley passes around a pulley, 5, on a horizontal shaft, 2, which revolves in bearings in the small frame A'. The hinder end of shaft 2 carries a pulley, *t*, which is connected by a band, S, with a pulley, *n*, above on the hinder end of a horizontal spindle, *i*, which carries on its forward end, beyond the frame A', a roll, 3, with conical sides, the declination of whose sides is outward from the frame. The spindle *i* runs in bearings on the top of frame A', and carries at any convenient place thereon a friction or cog wheel, *m*, which runs in contact with a similar wheel, *m*, on a spindle, 6, whose place is directly beneath spindle 4. Spindle 6 carries at its end beyond the frame A a feed-roll, *g*, with conical sides, the surface thereof being made of india-rubber or other suitable elastic material. The said shaft 2 carries also, at about the middle of its length, a large pulley, 1, a band from which goes over a small pulley or a groove made on a spindle, *j*, whose bearings are in an upper frame, *p*, which is so mounted above the frame A' on standards *q q* as to allow the said frame to oscillate on the said standards when the operator raises the front side thereof.

The spindle *j* carries at its forward end, beyond the frame A', a conical roll, *h*, with its base toward the frame A. This roll *h* is covered with emery or equivalent material, and its place is directly above the roll 3 above mentioned.

The upper frame, *p*, also carries a spindle, 4, which has a conical feed-roll, *g*, with elastic sides, like the feed-roll *g* of spindle 6.

The upper frame, *p*, is so mounted on the standards *q* as to be capable of oscillating thereon, the same being, when in its normal position, inclined forward, as shown in Fig. 2, because

its fulcra are in a line behind its center of gravity. The extent of this inclination and the inclination of the sides of the rolls *g g h* and 3 are determined on with respect to each other, so that the rolls of the upper frame will be parallel with those of the lower frame when they approach each other. The spindle 4 is made to revolve by means of its friction or cog wheel *l*, which is engaged or moved by the friction or cog wheel *l* of spindle 6, which spindle is turned through its wheel *m*, as above explained. The band *r* of pulley 1 is elastic to allow of the motion of frame *p* about its fulcra *q q*.

Those shafts and spindles which are described as being driven by bands and pulleys may be driven in any other suitable way.

The operation of the machine is as follows: The hat-body to be pounced is placed on the hat-block and the shaft N is made to revolve. The operator controls with his hand or by a suitable lever the hanging-frame E, which, it will be observed, is capable of vibration on its shaft D, so as to bring the emery cylinder or wheel to either side of the axis of the hat-block at pleasure. The revolution of the shaft N causes the spindle of the emery-cylinder L to be rotated by means of the bands *f* and H, and the pulleys over which they pass should be so made and arranged that the said emery-cylinder will be rotated at a high speed. The spindle J may be provided with a spiral or other spring or other suitable device to keep the emery-cylinder always against the crown of the hat or the crown of the block. At the same time the spindle which carries the hat-block is rotated at a comparatively low speed by means of the belt W. These movements of the emery cylinder or wheel and the hat-block will cause the said cylinder or wheel to pounce the crown of the hat-body before the operation of the worm O has had time to move the carriage *b* forward far enough to bring the sides of the block opposite the emery-cylinder, which may properly be called the "cutting-cylinder." The advance movement takes place slowly, so as to allow the emery or cutting cylinder to act upon all parts of the hat-body. When the body is sufficiently pounced the shaft Q is pushed toward the right, (observing Fig. 4,) whereby the wheel P is disengaged from worm O and from rack V of the carriage *b*, and said carriage is forced back by the spring *e* to its first position, the pulley T meanwhile, both in the advance and retreat of the carriage, being carried along by means of the arm U.

After the hat-body is removed from the block *a* its rim is subjected to the action of the conical emery-roll *h* in the following manner: This roll *h* is revolved at a high speed by means of belt *r* and pulley 1, and the roll 3 beneath is revolved at a slow speed. The feed-rolls *g g* are likewise driven through the friction or cog wheels *m m* and *l l* at a like speed with the slow roll 3. The frame *p* is raised a little way to allow the workman to introduce the brim

between the rolls in a horizontal line, so that it will be between the emery-roll *h* and the under supporting-roll, 3, and between the elastic feeding-rolls *g g*. The frame is then released, when the feed-rolls will cause the brim to advance between the emery-roll *g* and the plain roll *h*, whereby one of its surfaces will be pounced in a perfect manner, the conical shape of the rolls causing the edge of the brim to advance between them at a higher speed than the part which is next to the body of the hat.

So soon as a hat-body is removed from the block *a* another can be placed thereon and the pouncing be proceeded with, the devices for pouncing the body and the brim being independent of each other, though they are mounted in the same or in connected frames.

After one side or face of a brim is pounced the other may be presented to the emery-roll *h* in like manner.

This invention can also be applied to shaving hat-bodies before they are blocked. The same result can be attained by causing the emery or pouncing surface to be reciprocated after the manner of a jigger motion, instead of being rotated, the hat-body being likewise reciprocated and also slowly rotated, so as to present continually a fresh surface to the pouncing-surface, or else being merely rotated on an advancing carriage.

Having thus described our invention, we claim as new and desire to secure by Letters Patent—

1. The pouncing-cylinder *L*, or its equivalent, adapted to move at a comparatively high speed, in combination with the hat-block *a*,

adapted to move at a comparatively low speed operating substantially as described, whether the motion be rotary or otherwise.

2. Carrying a rotating cutting cylinder or wheel for pouncing hats in a vibrating frame, so that such cutting cylinder or wheel can act both on the crown and sides of hat-bodies which are stationary or are moving forward in a straight line, substantially as above shown.

3. Giving an advancing motion and at the same time a rotary motion to a hat-block upon which hat-bodies are placed to undergo the operation of pouncing, substantially as and for the purpose above set forth.

4. In combination, in machines for pouncing hat-bodies, the carriage *b*, the hat-block *a*, so mounted as to be capable of rotary motion; the worm *O*, cog-wheel *P*, and rack *V*, for moving the carriage forward, and a suitable spring for driving the carriage back when it is released from its driving-wheel *P*, substantially as above shown.

5. In combination, a conical emery rotating surface, *h*, for pouncing the brims of hat-bodies, and a conical supporting-surface 3, to hold the brim up to the cutting-surface, substantially as shown.

6. In combination, a conical rotating cutting-surface, *h*, for pouncing the brims of hat-bodies, and conical feeding-rolls with elastic surfaces *g g*, for feeding the brim to the cutting or pouncing surface, substantially as shown.

SIDNEY S. WHEELER.  
DANIEL B. MANLEY.

Witnesses:

AMZI WHEELER,  
MILO WILSON.