



US00D417651S

**United States Patent** [19]  
**Ohsumi**

[11] **Patent Number: Des. 417,651**

[45] **Date of Patent: \*\* Dec. 14, 1999**

[54] **POWER GENERATOR**

[75] Inventor: **Masayuki Ohsumi, Wako, Japan**

[73] Assignee: **Honda Giken Kogyo Kabushiki Kaisha, Tokyo, Japan**

[\*\*] Term: **14 Years**

[21] Appl. No.: **29/084,859**

[22] Filed: **Mar. 12, 1998**

[30] **Foreign Application Priority Data**

Feb. 12, 1997 [JP] Japan ..... 9-67609

[51] **LOC (6) Cl.** ..... **13-02**

[52] **U.S. Cl.** ..... **D13/116**

[58] **Field of Search** ..... D13/112, 114,  
D13/116; 290/1 A, 1 B; 307/150; 123/2,  
3

[56] **References Cited**

**U.S. PATENT DOCUMENTS**

D. 276,515	11/1984	Yaguchi	.....	D13/116
D. 282,252	1/1986	Yamaguchi et al.	.....	D13/116
D. 291,432	8/1987	Yaguchi	.....	D13/116
D. 305,880	2/1990	Ito et al.	.....	D13/116
D. 309,597	7/1990	Higuchi et al.	.....	D13/116
D. 335,862	5/1993	Kusunoki et al.	.....	D13/116
4,595,841	6/1986	Yaguchi	.....	290/1 A

*Primary Examiner*—Joel Sincavage

*Attorney, Agent, or Firm*—Blank Rome Comisky & McCauley LLP

[57] **CLAIM**

The ornamental design for a power generator, as shown and described.

**DESCRIPTION**

FIG. 1 is a front elevational view of a power generator showing my new design;

FIG. 2 is a rear elevational view of the power generator shown in FIG. 1;

FIG. 3 is a left side elevational view of the power generator shown in FIG. 1;

FIG. 4 is a right side elevational view of the power generator shown in FIG. 1;

FIG. 5 is a top plan view of the power generator shown in FIG. 1;

FIG. 6 is a bottom plan view of the power generator shown in FIG. 1;

FIG. 7 is a front perspective view of the power generator shown in FIG. 1;

FIG. 8 is another front perspective view of the power generator shown in FIG. 1;

FIG. 9 is a rear perspective view of the power generator shown in FIG. 1;

FIG. 10 is a front elevational view of another embodiment of the power generator showing my new design;

FIG. 11 is a rear elevational view of the power generator of FIG. 10;

FIG. 12 is a left side elevational view of the power generator of FIG. 10;

FIG. 13 is a right side elevational view of the power generator of FIG. 10;

FIG. 14 is a top plan view of the power generator of FIG. 10;

FIG. 15 is a bottom plan view of the power generator of FIG. 10;

FIG. 16 is a front perspective view of the power generator of FIG. 10;

FIG. 17 is another front perspective view of the power generator of FIG. 10; and,

FIG. 18 is a rear perspective view of the power generator of FIG. 10.

The broken line showing in FIGS. 10-14 and 16-18 show features of the generator which form no part of the design embodied in FIG. 10.

**1 Claim, 12 Drawing Sheets**

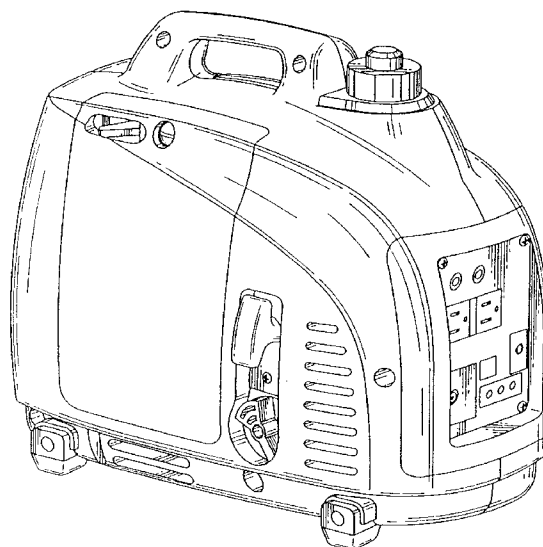

FIG. 1

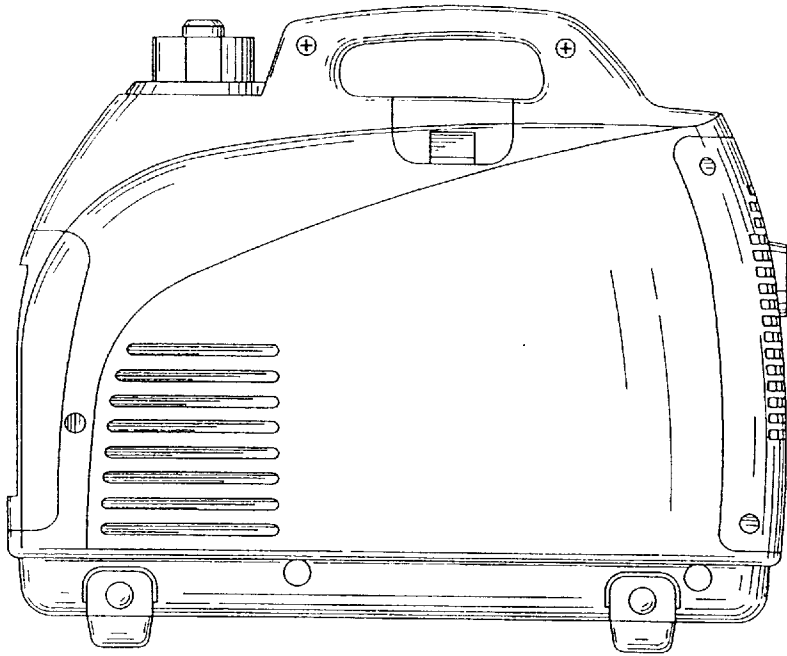

FIG. 2

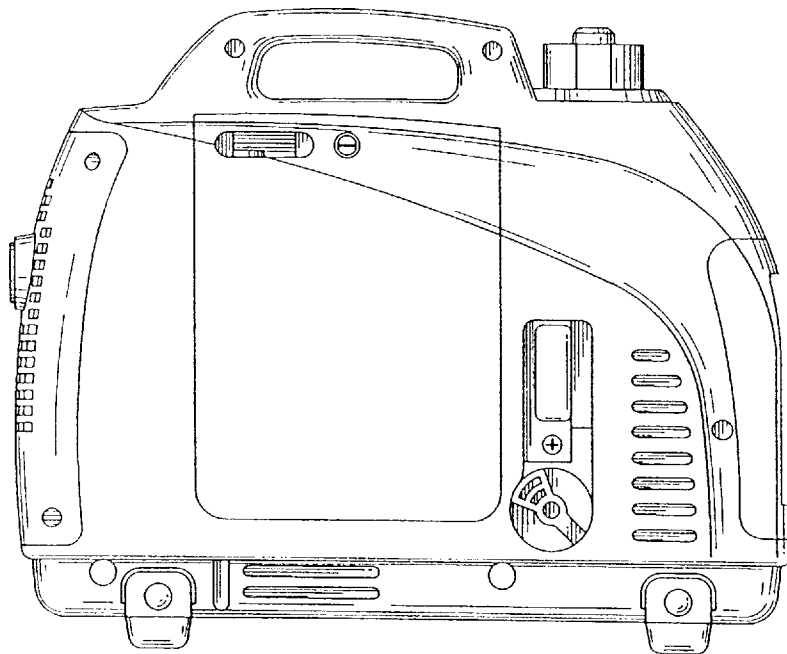

FIG. 3

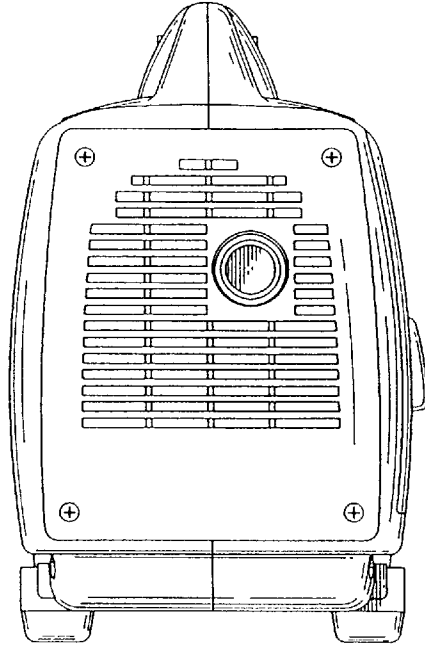

FIG. 4

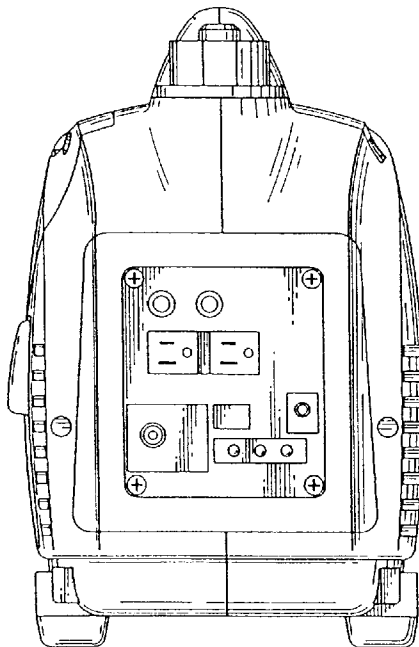

FIG. 5

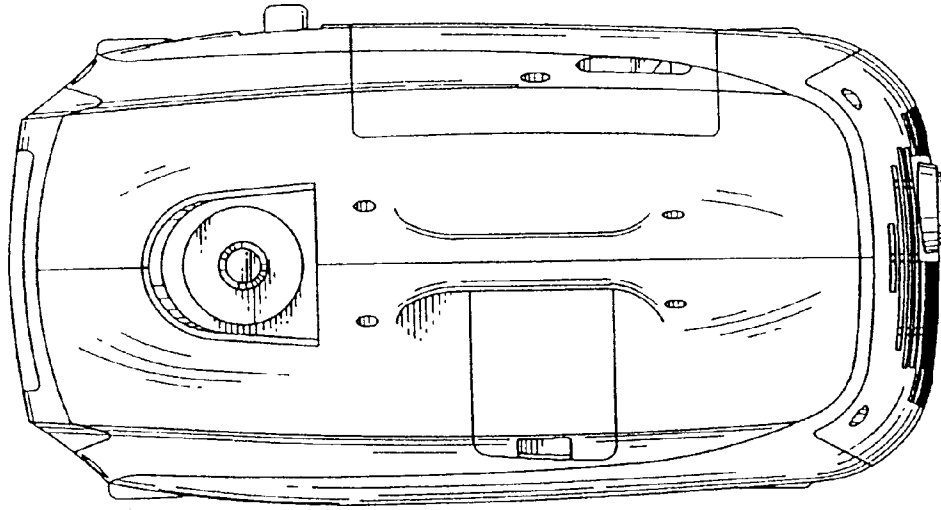

FIG. 6

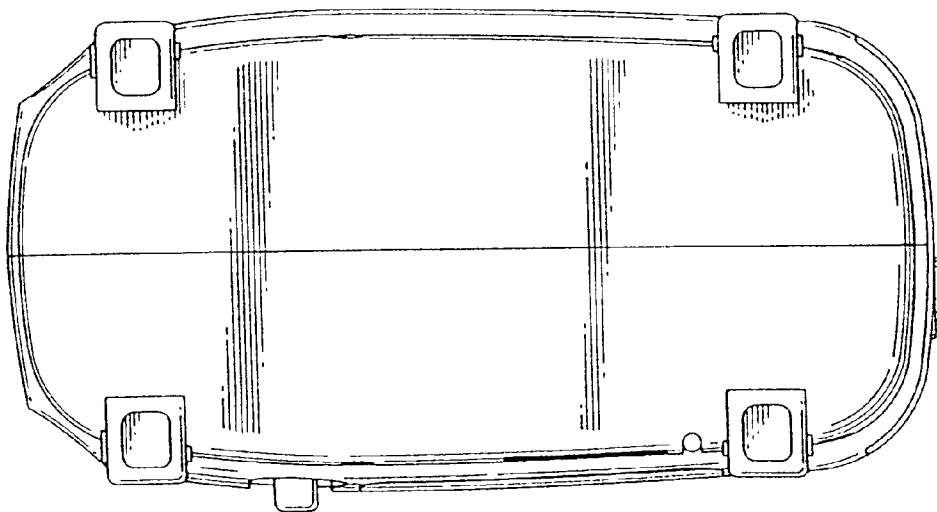

FIG. 7

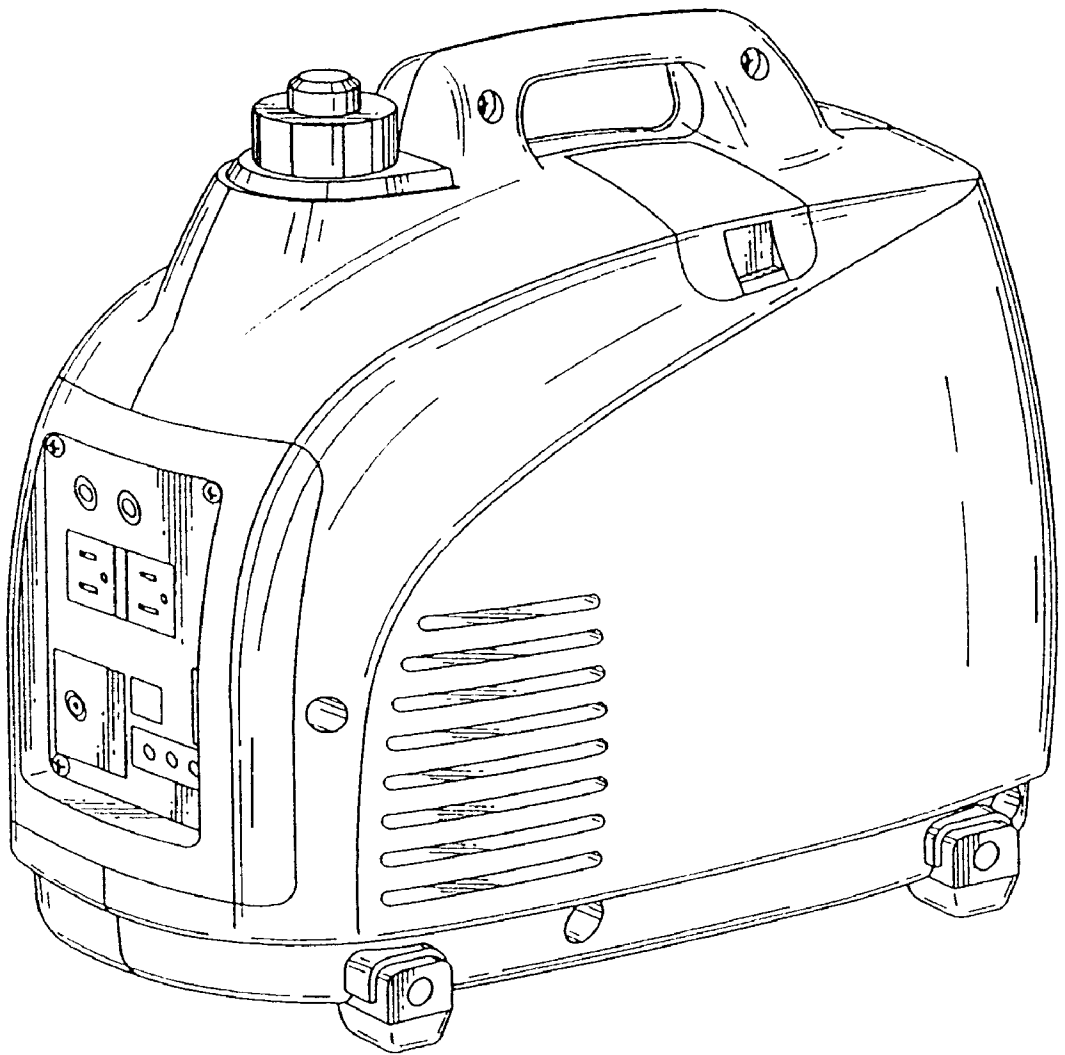

FIG. 8

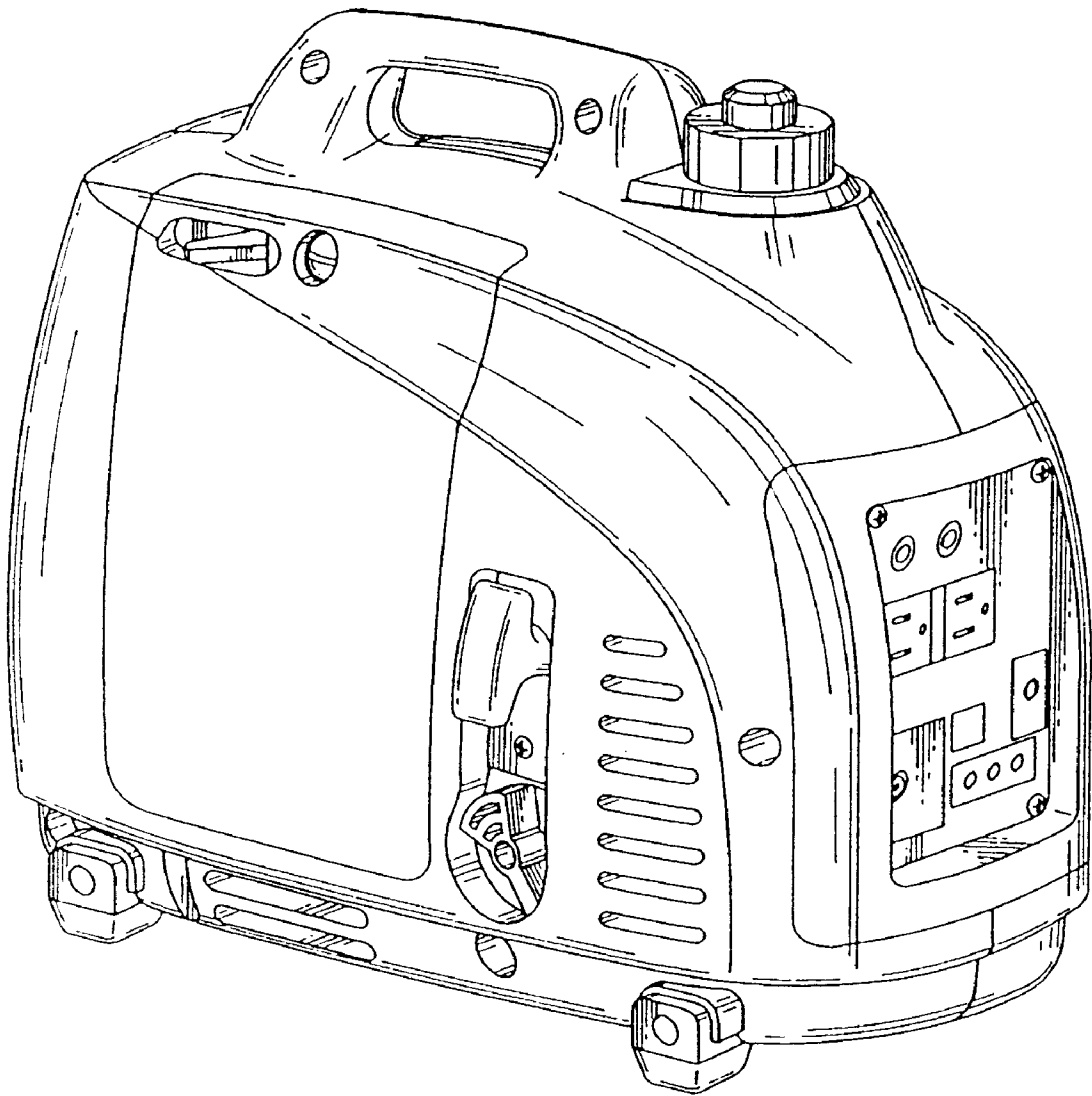

FIG. 9

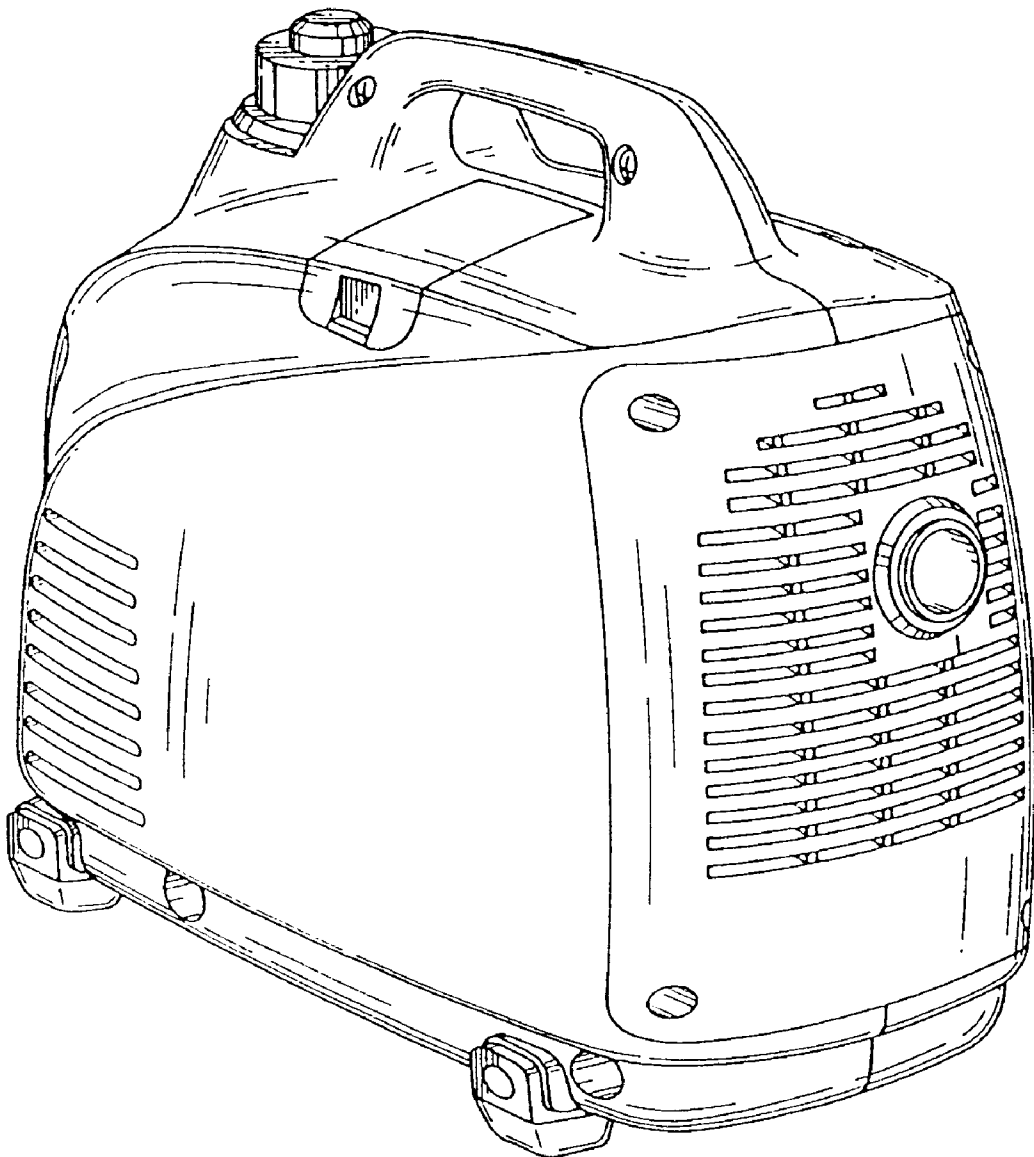

FIG. 10

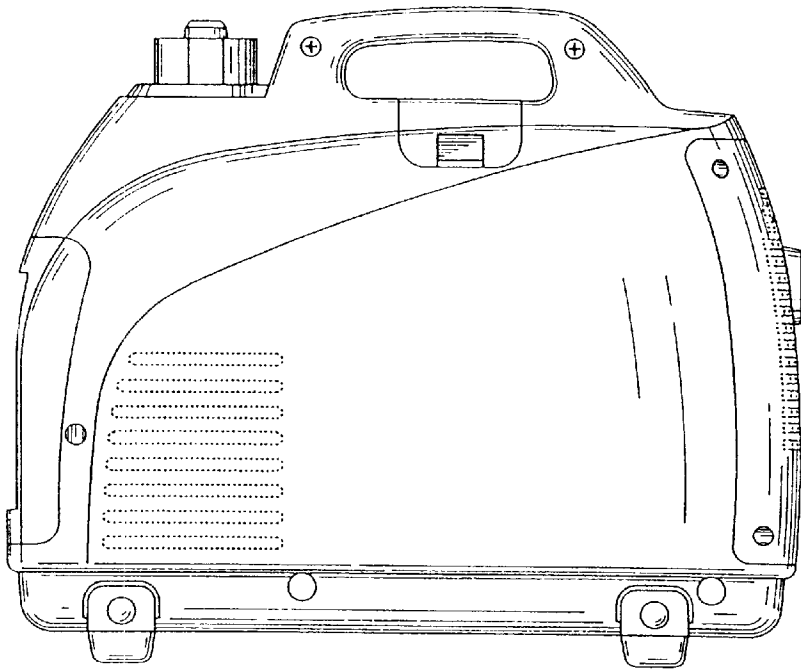

FIG. 11

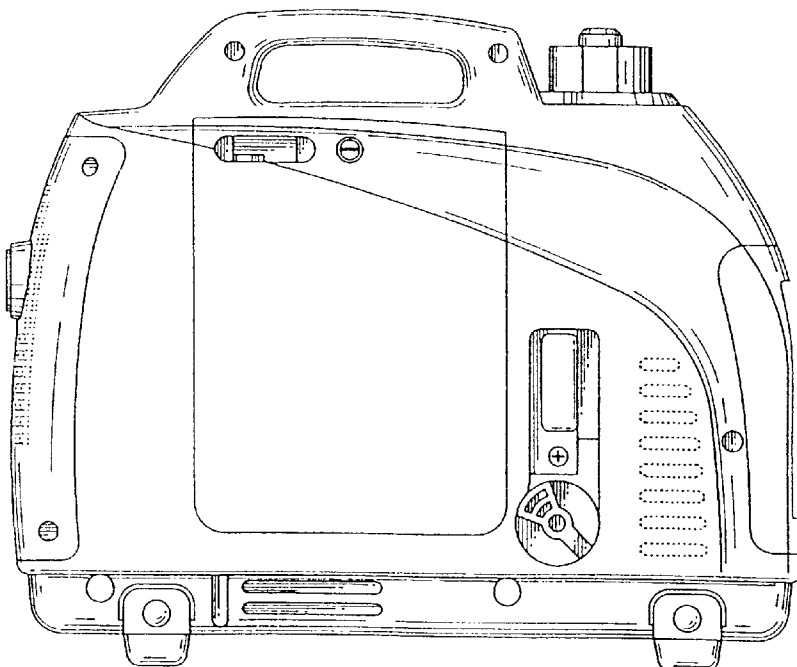



FIG. 12

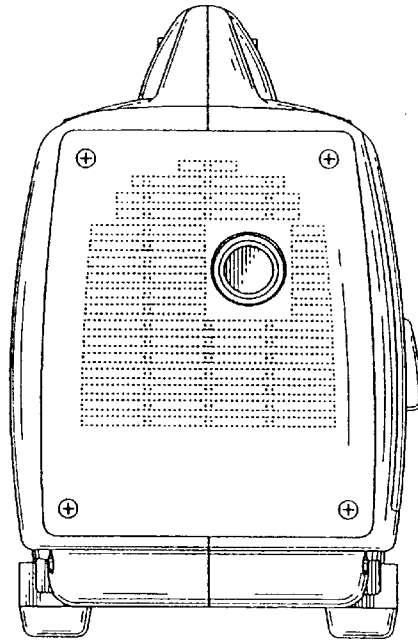

FIG. 13

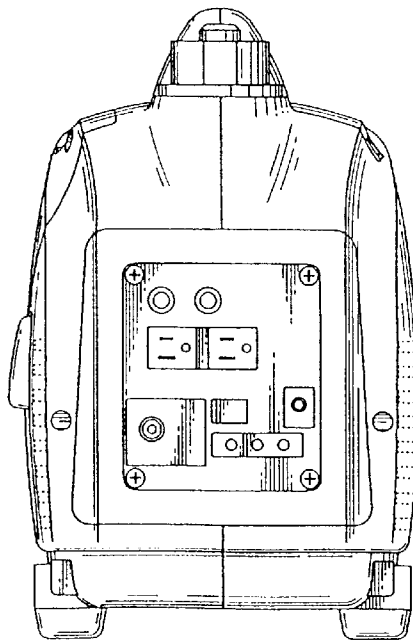

FIG. 14

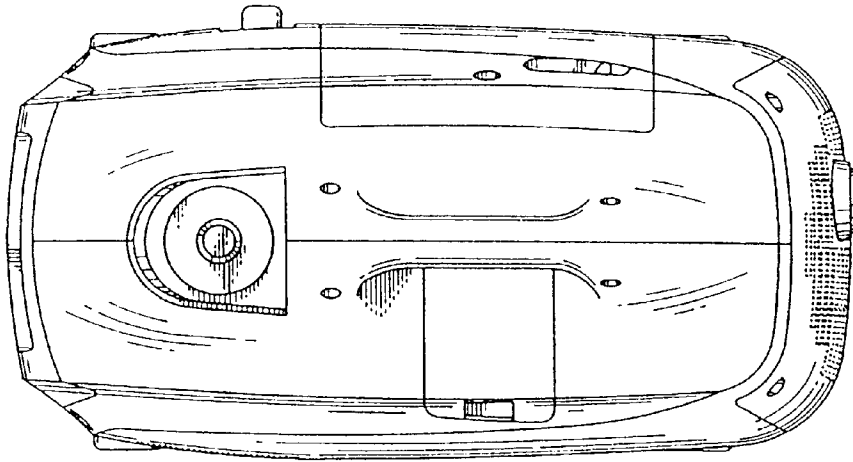

FIG. 15

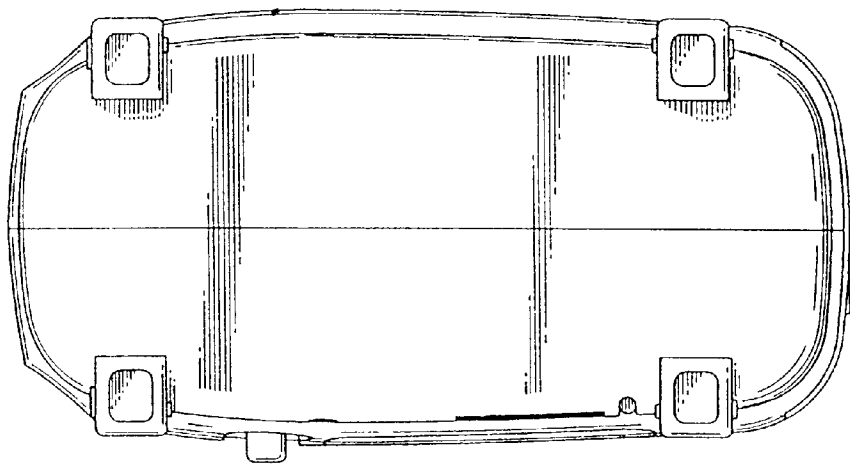

FIG. 16

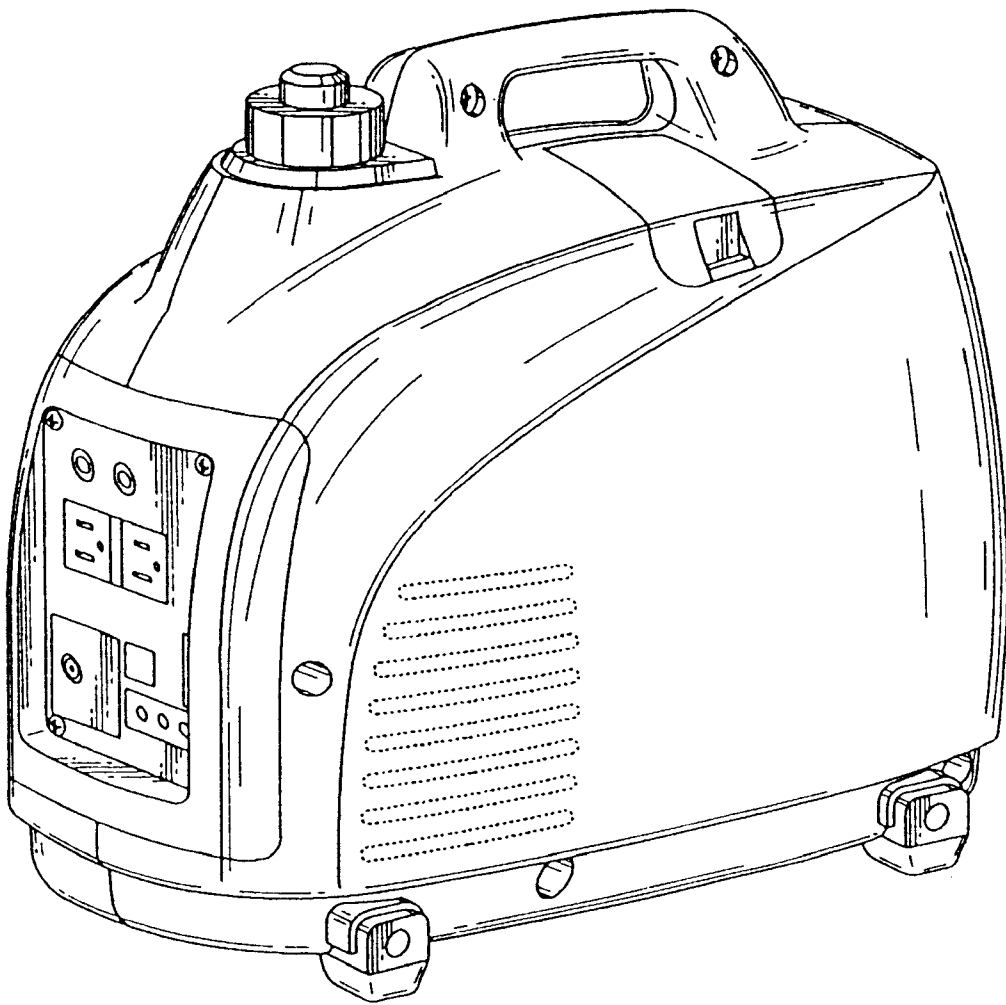

FIG. 17

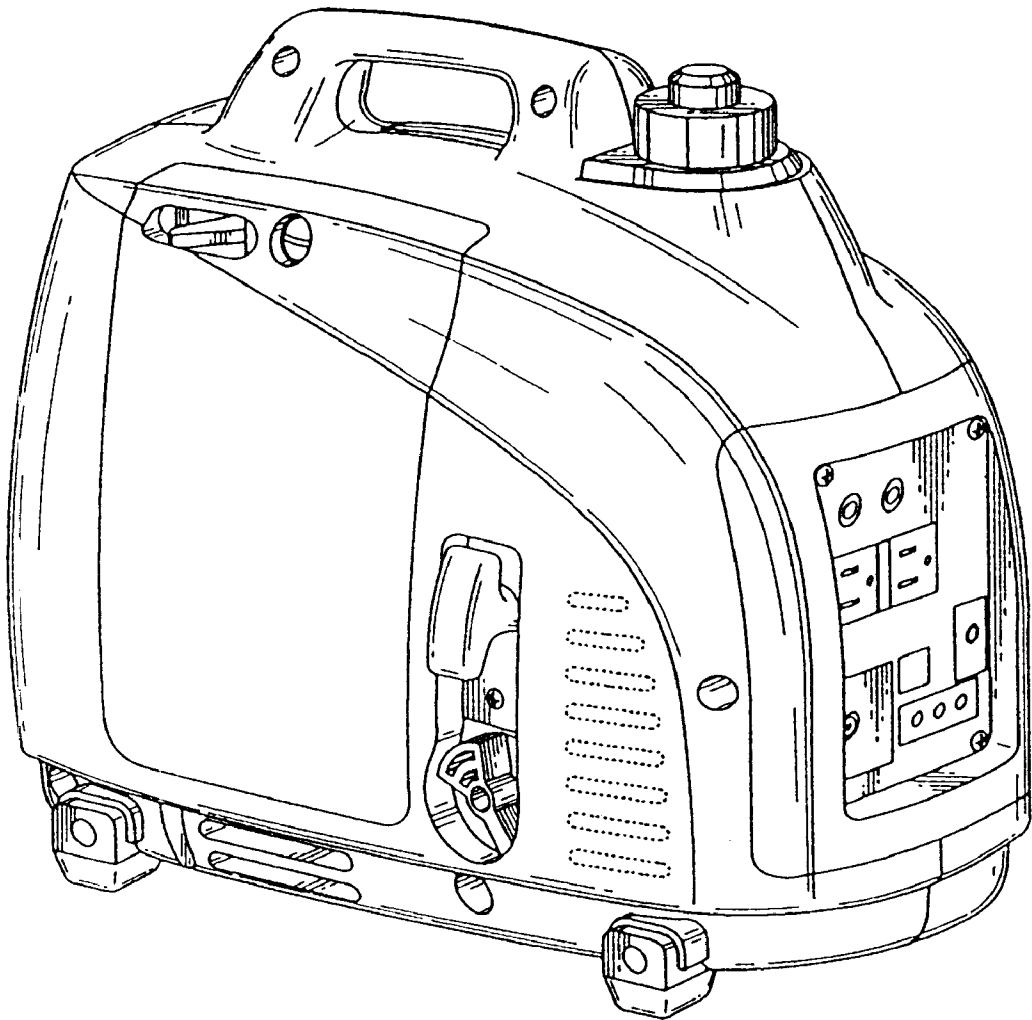

FIG. 18

