

(No Model.)

F. E. CHURCH.
SPRING TOOTH HARROW.

No. 423,218.

Patented Mar. 11, 1890.

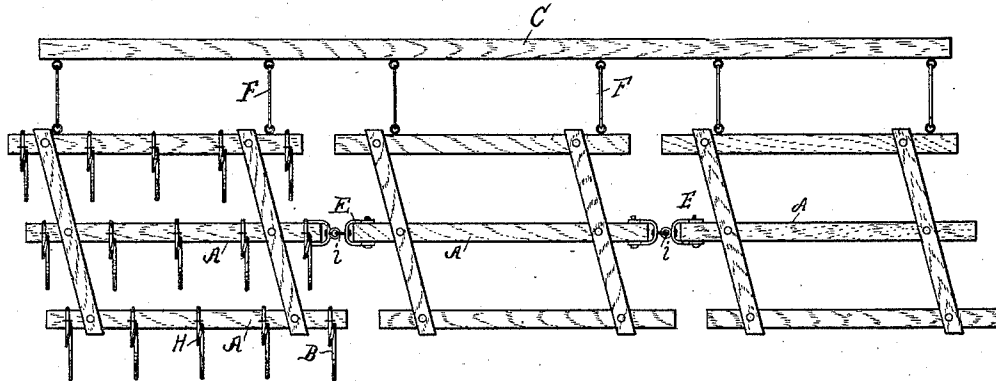

Fig. 1

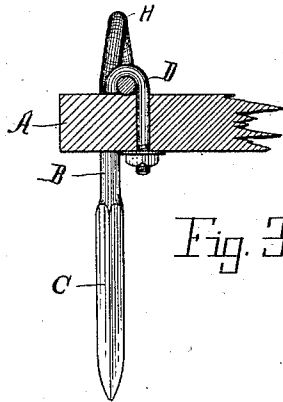

Fig. 3

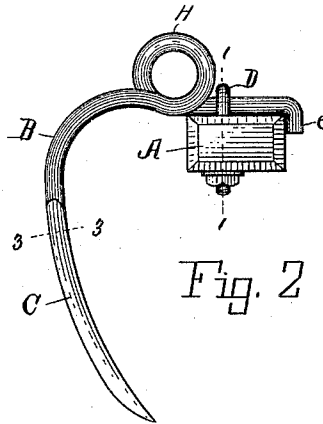

Fig. 2

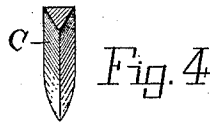

Fig. 4

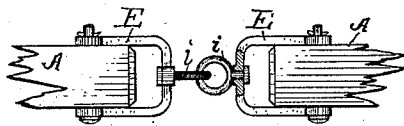

Fig. 5

WITNESSES:

Walter S. Wood

John G. Freeman

INVENTOR

Francis C. Church

BY

Lucius C. West

ATTORNEY

UNITED STATES PATENT OFFICE.

FRANCIS E. CHURCH, OF KALAMAZOO, MICHIGAN.

SPRING-TOOTH HARROW.

SPECIFICATION forming part of Letters Patent No. 423,218, dated March 11, 1890.

Application filed November 16, 1889. Serial No. 330,554. (No model.)

To all whom it may concern:

Be it known that I, FRANCIS E. CHURCH, a citizen of the United States, residing at Kalamazoo, county of Kalamazoo, State of Michigan, have invented a new and useful Spring-Tooth Harrow, of which the following is a specification.

This invention has for its object the peculiar construction substantially as below described and claimed.

In the drawings forming a part of this specification, Figure 1 is a plan view. Fig. 2 is an enlarged end elevation of one of the tooth-bars in Fig. 1 and side elevation of one of the teeth attached thereto. Fig. 3 is a section on line 1 1 in Fig. 2, looking from a point at the right. Fig. 4 is a cross-section on line 3 3 in Fig. 2, looking from a point above; and Fig. 5 shows enlarged lettered details from Fig. 1.

At A are shown the tooth-bars of the harrow-frame.

The frame as here shown consists of three sections, as in Fig. 1, each section being jointly connected together by the links *i i* and the clevis E E, said links being connected in a swiveled manner, as in Fig. 1, but more clearly illustrated in Fig. 5, in which figure a portion of the right-hand clevis E E is broken away, showing the swiveled attachment of one of the links *i i* to said clevis. By this means the sections of the frame can tilt up and down endwise and sidewise, according to the varying contour of the surface of the soil. These sections are attached by draw-bars F to the long bar C, and to said bars as many

whiffletrees may be attached as desired, according to the number of horses used. (No whiffletrees are here shown.)

The harrow-tooth is made out of a round rod of spring metal, having a shank which is attached to the beam A by the staple-bolt D, Figs. 2 and 3, said shank having an angled end *e* catching over the front side of the beam A. Back of the shank the rod is bent to form a loop H, and from said loop the remainder of the tooth is C-shaped or curved, as in Fig. 2.

The working end of the tooth is hammered or pressed so as to have three sides, and hence triangular in shape in cross-section, as in Fig. 4, thus presenting one of the apexes of two of the converging sides to the front. This makes a strong tooth with sufficient elasticity out of light-weight metal, and a tooth that easily cuts its way through the soil.

Having thus described my invention, what I claim as new, and desire to secure by Letters Patent of the United States, is—

The round metal harrow-tooth having its working end below the elastic-bowed body pressed or hammered, so as to make said end solid and triangular in cross-section, substantially as set forth.

In testimony of the foregoing I have hereto subscribed my name in presence of two witnesses.

FRANCIS E. CHURCH.

Witnesses:

BELLE FREEMAN,
L. N. BURKE.