

(19)



(11)

EP 3 661 258 B1

(12)

EUROPEAN PATENT SPECIFICATION

(45) Date of publication and mention of the grant of the patent:
06.11.2024 Bulletin 2024/45

(21) Application number: **17919560.7**

(22) Date of filing: **28.07.2017**

(51) International Patent Classification (IPC):
H04W 48/12 ^(2009.01) **H04L 5/00** ^(2006.01)
H04W 72/23 ^(2023.01) **H04W 28/08** ^(2023.01)
H04W 28/02 ^(2009.01) **H04W 72/0453** ^(2023.01)

(52) Cooperative Patent Classification (CPC):
H04W 48/12; H04L 5/001; H04W 28/0908;
H04W 72/23; H04L 5/0053; H04W 28/0231;
H04W 72/0453

(86) International application number:
PCT/CN2017/095040

(87) International publication number:
WO 2019/019187 (31.01.2019 Gazette 2019/05)

(54) METHODS AND A TERMINAL FOR ACQUIRING CONTROL INFORMATION

VERFAHREN UND EIN TERMINAL ZUM ERFASSEN VON STEUERINFORMATIONEN
PROCÉDÉS ET TERMINAL D'ACQUISITION D'INFORMATIONS DE COMMANDE

(84) Designated Contracting States:
AL AT BE BG CH CY CZ DE DK EE ES FI FR GB GR HR HU IE IS IT LI LT LU LV MC MK MT NL NO PL PT RO RS SE SI SK SM TR

(43) Date of publication of application:
03.06.2020 Bulletin 2020/23

(73) Proprietor: **Beijing Xiaomi Mobile Software Co., Ltd.**
Beijing 100085 (CN)

(72) Inventors:
• **ZHOU, Juejia**
Beijing 100085 (CN)
• **ZHU, Yajun**
Beijing 100085 (CN)

(74) Representative: **Dehns Germany Partnerschaft mbB**
Theresienstraße 6-8
80333 München (DE)

(56) References cited:
WO-A1-2010/050887 WO-A1-2015/144850
CN-A- 106 717 054 US-A1- 2011 026 475
US-A1- 2015 264 689

- **HUAWEI ET AL: "Bandwidth adaptation and scalable design in NR", vol. RAN WG1, no. Athens, Greece; 20170213 - 20170217, 12 February 2017 (2017-02-12), XP051208811, Retrieved from the Internet**
<URL:http://www.3gpp.org/ftp/Meetings_3GPP_SYNC/RAN1/Docs/> [retrieved on 20170212]
- **HUAWEI ET AL: "On bandwidth part and bandwidth adaptation", vol. RAN WG1, no. Hangzhou, China; 20170515 - 20170519, 14 May 2017 (2017-05-14), XP051272131, Retrieved from the Internet**
<URL:http://www.3gpp.org/ftp/Meetings_3GPP_SYNC/RAN1/Docs/> [retrieved on 20170514]
- **INTERDIGITAL ET AL: "Bandwidth Adaptation via BWP Selection in NR", vol. RAN WG1, no. Qingdao, China; 20170627 - 20170630, 16 June 2017 (2017-06-16), XP051304542, Retrieved from the Internet**
<URL:http://www.3gpp.org/ftp/tsg_ran/WG1_RL1/TSGR1_AH/NR_AH_1706/Docs/> [retrieved on 20170616]
- **HUAWEI ET AL: "Mechanisms of bandwidth adaptation", vol. RAN WG1, no. Spokane, USA; 20170116 - 20170120, 16 January 2017 (2017-01-16), XP051207553, Retrieved from the Internet**
<URL:http://www.3gpp.org/ftp/Meetings_3GPP_SYNC/RAN1/Docs/> [retrieved on 20170116]

Note: Within nine months of the publication of the mention of the grant of the European patent in the European Patent Bulletin, any person may give notice to the European Patent Office of opposition to that patent, in accordance with the Implementing Regulations. Notice of opposition shall not be deemed to have been filed until the opposition fee has been paid. (Art. 99(1) European Patent Convention).

EP 3 661 258 B1

Description

TECHNICAL FIELD

[0001] The present disclosure relates to the field of communication technology, and more particularly to methods performed respectively by a base station and a terminal, as well as a corresponding terminal, for acquiring control information.

BACKGROUND

[0002] NR (New Radio) technology in 5G (Fifth-generation of Wireless Mobile Telecommunications Technology) is similar to LTE (Long Term Evolution) technology in 4G (Fourth-generation of Wireless Mobile Telecommunications Technology), and is also an air interface technology with a time-frequency structure, where time-frequency resources are used, the time dimension is divided into different OFDM (Orthogonal Frequency Division Multiplexing) symbols, and the frequency dimension is divided into different sub-carriers.

[0003] In 5G, the frequency deployed for the NR is mostly in a high-frequency range and may be deployed from 3.3GHz to 24GHz, and thus, the carrier frequency range of the NR in 5G may be much larger than the carrier range of the LTE in 4G. As such, for one UE (User Equipment) and from the perspective of radio frequency capability and power consumption, a frequency band of the NR in 5G is divided into a plurality of BWPs (Band Width Part), and the UE is configured to work at at least one BWP at the same time. There is one RORESET (Control Resource Set) present in each BWP correspondingly, and the RORESET is a set of all the control information in the BWP to which it belongs, including such as control information, reference signals, etc. In general, a base station sends the RORESET to the UE via preset time-frequency resources in the BWP, and the UE working at the BWP may acquire the control information corresponding to itself in the RORESET from the preset time-frequency resources.

[0004] D1 (US20110026475A1) discloses a method and apparatus for performing carrier management in a broadband wireless communication system supporting multiple carriers. The method for a mobile station to perform carrier management procedure with a base station supporting multiple carriers includes receiving a carrier management command message from the base station, the carrier management command message including an action code for carrier management and a polling bit in a MAC Control Extended Header (MCEH) indicating whether an acknowledgement message is required, transmitting the acknowledgement message in response to the carrier management command message to the base station when the carrier management command message is successfully received and the polling bit is set to 1, and transmitting a carrier management indication message corresponding to the action code in-

cluded in the carrier management command message to the base station.

[0005] D2 (WO 2010/050887 A1) discloses a method and arrangement in a base station for scheduling communication between the base station and a user equipment in a multi-carrier communication network system. The base station and the user equipment are comprised in the multi-carrier communication network system, and adapted to communicate with each other on downlink carriers and uplink carriers in at least a first frequency band and a second frequency band over a radio interface. The method comprises signaling an indication to the user equipment on the downlink carrier in the first frequency band, which the user equipment currently is scheduled on, to switch to a second carrier in order to communicate data and/or control signaling on the second carrier. In addition, a method and an arrangement in a user equipment for assisting the base station in scheduling radio resources are described.

[0006] D3 (by HUAWEI ET AL: "Bandwidth adaptation and scalable design in NR", 3GPP DRAFT: R1-1701644) discloses bandwidth adaptation and scalable design in NR.

SUMMARY

[0007] To overcome the problems existing in the related art, the present disclosure provides a method, an apparatus and a system for acquiring control information. The technical solutions are as follows:

According to a first aspect of the present invention, there is provided a method comprising the features of claim 1.

[0008] According to a second aspect of the present invention, there is provided a method comprising the features of claim 5.

[0009] According to a third aspect of the present invention, there is provided a terminal, comprising the features of claim 8.

[0010] The technical solutions provided by the embodiments of the present disclosure may include the following beneficial effects.

[0011] A terminal receives indication information sent by a base station, wherein the indication information is configured to indicate a standby BWP that is used when a BWP switching failure occurs, and the BWP indicated by the indication information is a BWP at which a terminal works currently, a BWP at which the terminal works previously, and any of preset BWPs; the BWP indicated by the indication information is switched to when the BWP switching is detected to have failed; and control information corresponding to the terminal that is sent by the base station at the BWP indicated by the indication information is received. In this way, when the BWP switching failure occurs, the terminal may acquire control information corresponding to itself from the BWP indicated by the base station, leading to low possibility of getting offline by the terminal.

BRIEF DESCRIPTION OF THE DRAWINGS

[0012] In order to describe the technical solutions in the embodiments of the present more clearly, the following briefly introduces the accompanying drawings required for describing the embodiments. Apparently, the accompanying drawings in the following description show merely some embodiments of the present disclosure, and a person of ordinary skill in the art may also derive other drawings from these accompanying drawings without creative efforts.

FIG. 1 is a schematic diagram of a system for acquiring control information according to an embodiment of the present disclosure;

FIG. 2 is a flowchart of a method for acquiring control information according to an embodiment of the present disclosure;

FIG. 3 is a schematic diagram of BWP switching according to an embodiment of the present disclosure; FIG. 4 is a schematic structural diagram of a terminal according to an embodiment of the present disclosure.

FIG. 5 is a schematic structural diagram of a terminal according to another embodiment of the present disclosure.

FIG. 6 is a schematic structural diagram of a base station according to an embodiment of the present disclosure; and

FIG. 7 is a schematic structural diagram of a terminal according to another embodiment of the present disclosure.

DETAILED DESCRIPTION

[0013] Reference will now be made in detail to exemplary embodiments, examples of which are illustrated in the accompanying drawings. The following description refers to the accompanying drawings in which the same numbers in different drawings represent the same or similar elements unless otherwise represented. The implementations set forth in the following description of exemplary embodiments do not represent all implementations consistent with the present disclosure. Instead, they are merely examples of apparatuses and methods consistent with aspects related to the disclosure as recited in the appended claims.

[0014] Sometimes, when the UE has a service requirement, the base station sends a BWP switching instruction to the UE. For example, the UE needs to switch from a BWP with a small frequency range to a BWP with a large frequency range when the size of the data to be sent thereby is large, and the like. After receiving the BWP switching instruction sent by the base station, the UE parses the BWP switching instruction to obtain the BWP to be switched to, and switches from a current BWP at which it works to the BWP obtained through parsing. However, in a BWP switching process, there may be

BWP switching failures. For example, the UE receives the BWP switching instruction sent by the base station, but due to an error occurring during the parsing of the BWP switching instruction, obtains a wrong BWP through parsing and switches to the wrong BWP, and the like. In this way, the UE may not obtain the control information belonging to itself from the control resource set corresponding to the post-switching BWP, and may neither be dispatched nor receive the data sent by the base station, leading to the UE getting offline.

[0015] An exemplary embodiment of the present disclosure provides a method for acquiring control information. As shown in FIG. 1, the method for acquiring control information may be implemented by a base station and a terminal jointly.

[0016] The terminal may be a mobile phone, a tablet computer and other devices capable of using the mobile communication network, and the terminal may be provided with a processor, a memory, a transceiver, etc.; the processor may be configured to handle a process of acquiring control information; the memory may be configured to store data required and data produced in the process of acquiring control information; the transceiver may be configured to receive and send messages; and the terminal may be further provided with an input/output device such as a screen, which may be configured to display signal quality and the like and may be a touch screen.

[0017] The base station may be provided with a processor, a transceiver, a memory, etc.; the processor may be configured for relevant handling in the process of acquiring control information; the transceiver may be configured to receive and send data; and the memory may be configured to store data required and data produced in the process of acquiring control information.

[0018] As shown in FIG. 2, a process flow of the method may include the following steps.

[0019] In step 201, the base station sends the indication information to the terminal.

[0020] Among them, the indication information is configured to indicate a standby BWP that is used when the terminal has a BWP switching failure, that is, the standby BWP is a BWP to which the terminal switches when the BWP switching failure occurs. The BWP indicated by the indication information is any of a BWP at which a terminal works currently, a BWP at which the terminal works previously, and preset BWP. In general, the terminal may work at multiple BWPs at the same time. The BWP at which the terminal works currently refers to multiple BWPs at which the terminal works currently at the same time; the BWP at which the terminal works previously refers to BWPs at which the terminal works before the current time point; and the preset BWP may be any of all the BWPs.

[0021] In implementation, after each terminal starts up and accesses the network, the base station may send the indication information to the terminal via the broadcast signaling, the upper-layer signaling, or the physical-

layer instruction, and the upper-layer signaling may be a signaling based on RRC (Radio Resource Control), or a signaling sent via MAC (Media Access Control). In an embodiment of the present disclosure, a terminal is described in detail, and the processes of other terminals are the same. If the standby BWP is the preset BWP when the terminal has a BWP switching failure, the indication information may be information that carries an identifier of the preset BWP, such as a frequency range of the preset BWP. If the standby BWP is the BWP at which the terminal works currently ("currently" here refers to the time when the switching failure occurs) or previously when the terminal has a BWP switching failure, the indication information may indicate how to select the BWP to be switched to, such as the indication information being the information notifying to select the BWP with the broadest frequency band among the BWPs at which the terminal works currently when the BWP switching failure occurs, or being the information notifying to select the BWP closest to the current time point among the BWPs at which the terminal works previously when the BWP switching failure occurs, or the like.

[0022] In step 202, the terminal receives the indication information sent by the base station.

[0023] In implementation, the terminal may receive the indication information sent by the base station, and store the indication information.

[0024] In step 203, the terminal switches to the BWP indicated by the indication information when detecting that the BWP switching failure occurs.

[0025] In implementation, as shown in FIG. 3, if the terminal has not detected the control information of its own when it reaches the condition for acquiring the control information (this process will be described later in detail), it is determined that the BWP switching failure occurs. When detecting that the BWP switching failure occurs, the terminal acquires the stored indication information, parses the indication information to obtain the BWP indicated by the indication information, and then switches to the BWP indicated by the indication information.

[0026] The BWP indicated by the indication information is switched to when a duration since last successful demodulation to the control information corresponding to the terminal reaches a first duration.

[0027] Among them, the first duration is a preset value, or a value computed based on a first reference duration, a BWP parameter corresponding to a pre-switching BWP, and a preset computing method. The preset value may also be preset by a technician and stored in the terminal, or received from the base station. The first reference duration may also be preset by a technician and stored in the terminal, or received from the base station. The BWP parameter includes a sub-carrier spacing of the pre-switching BWP, a bandwidth of the pre-switching BWP, and the like. The preset computing method may also be preset by the technician and stored in the terminal, or received from the base station. For example, the

preset computing method may be $t1=T/(\text{BWP parameter}/15(\text{KHz}))$, with $t1$ being the first duration, T being the first reference duration, and the BWP parameter being the sub-carrier spacing of the pre-switching BWP; and the preset computing method may also be $t1=T*(\text{BWP parameter}/5(\text{MHz}))$, with $t1$ being the first duration, T being the first reference duration, and the BWP parameter being the bandwidth of the pre-switching BWP.

[0028] In implementation, in general, the base station periodically sends the control information corresponding to the terminal in the BWP at which the terminal works currently; sometimes when determining that the terminal needs to perform the BWP switching, the base station may send a BWP switching instruction to the terminal; when the terminal does not receive the BWP switching instruction but the base station considers that the terminal has switched to the BWP indicated by the BWP switching instruction, the base station sends the control information corresponding to the terminal in the post-switching BWP, rather than in pre-switching BWP; in this way, the terminal may detect that the duration since last successful demodulation to the control information corresponding to itself reaches the first duration, and the terminal may acquire the stored indication information, parse the indication information to obtain the BWP indicated by the indication information, and then switch to the BWP indicated by the indication information.

[0029] It should be noted that each time when the control information corresponding to the terminal is successfully demodulated from the BWP, the terminal re-times from zero to determine whether the duration since the last successful demodulation to the control information corresponding to the terminal reaches the first duration.

[0030] The terminal receives configuration information of the first duration that is sent by the base station via a broadcast signaling, an upper-layer signaling, or a physical-layer signaling.

[0031] Among them, the configuration information includes a first reference duration and a preset computing method. The first reference duration, such as 1 ms, may be preset by a technician and stored in the base station. The preset computing method may also be preset by the technician, and stored in the base station.

[0032] In implementation, after the terminal starts up and accesses the network, the base station may send the configuration information of the first duration to the terminal via the broadcast signaling, the upper-layer signaling, or the physical-layer instruction, and the upper-layer signaling may be a signaling based on RRC (Radio Resource Control), or a signaling sent via the MAC (Media Access Control). After receiving the configuration information sent by the base station, the terminal may store the configuration information of the first duration.

[0033] In addition, the configuration information may further include a BWP parameter of the pre-switching BWP, such as a bandwidth of the pre-switching BWP, a sub-carrier spacing of the pre-switching BWP, etc.

[0034] The first duration is expressed by a length of

time, a number of unit time-domain resources, or a number of code block groups.

[0035] In implementation, the first duration may be expressed by a length of time, such as 5 ms and the like as the first duration.

[0036] The first duration may also be expressed by a number of unit time-domain resources. For example, the unit time-domain resource may be a symbol, a time slot, a sub-frame, etc.; the first duration may be a time slot, i.e. 0.5 ms; and the first duration is a sub-frame, i.e. 1 ms.

[0037] The first duration may also be expressed by a number of code block groups. In general, one TTI may contain multiple code block groups, and the duration of each TTI is 1 ms, and thus, the number of code block groups may be used for timing. For example, if one TTI includes 5 code block groups, each of which has a duration of 0.2 ms, and the number of the code block groups is 3, then the first duration is 0.6 ms.

[0038] In step 204, the base station sends control information corresponding to the terminal to the terminal at the BWP indicated by the indication information.

[0039] In implementation, when the BWP indicated by the indication information is a preset BWP, a pre-switching BWP, or a post-switching BWP, the base station may send the corresponding control information to the terminal at the BWP indicated by the indication information when determining that the terminal has a BWP switching failure (the process will be described later in detail).

[0040] In addition, when the BWP indicated by the indication information is a preset BWP, the base station may send the control information corresponding to the terminal in the preset BWP in each cycle. In this way, it is unnecessary for the base station to determine whether the terminal has a BWP switching failure.

[0041] Optionally, when the switching success notification is not received, the control information corresponding to the terminal may be sent to the terminal, and the corresponding step 204 may include the following process:

sending control information corresponding to the terminal to the terminal at the BWP indicated by the indication information when a BWP switching success notification sent by the terminal is not received within a third duration after a BWP switching instruction is sent to the terminal.

[0042] Among them, the third duration may be preset by the technician and stored in the base station, or may be computed from the first duration, such as by adding an offset to the first duration to obtain the third duration, where the offset here represents the sum of a transmission duration and a parsing duration of the BWP switching instruction.

[0043] In implementation, when determining that the terminal needs to perform the BWP switching, the base station may send a BWP switching instruction to the terminal; the timing starts after the BWP switching instruction is sent; when the duration reaches the third duration and the BWP switching success notification sent by the terminal has not been received, the base station deter-

mines that the terminal has a BWP switching failure. The base station may send corresponding control information to the terminal periodically at the BWP indicated by the indication information.

5 **[0044]** Optionally, the third duration may also be expressed by a length of time, a number of unit time-domain resources, or a number of code block groups.

[0045] Optionally, when the terminal may not switch to the BWP indicated by the indication information all along due to its own reasons (such as a fault), the base station may stop sending the corresponding control information to the terminal, and a corresponding process may be as follows:

10 stopping sending the control information corresponding to the terminal to the terminal at the BWP indicated by the indication information when a BWP switching failure notification sent by the terminal is not received within a fourth duration after the control information corresponding to the terminal is sent to the terminal at the BWP indicated by the indication information.

15 **[0046]** Among them, the fourth duration may be preset by a technician and stored in the base station.

[0047] In implementation, after the base station sends the corresponding control information to the terminal for the first time at the BWP indicated by the indication information, the base station may start timing; when the duration reaches the fourth duration and the BWP switching failure notification sent by the terminal has not been received, the base station does not send the control information corresponding to the terminal to the terminal at the BWP indicated by the indication information, thereby saving transmission resources.

25 **[0048]** Optionally, the fourth duration may also be expressed by a length of time, a number of unit time-domain resources, or a number of code block groups.

[0049] In step 205, the terminal receives control information corresponding to the terminal that is sent by the base station at the BWP indicated by the indication information.

30 **[0050]** In implementation, after switching to the BWP indicated by the indication information, the terminal may obtain the control information of its own by demodulating the BWP, so that the terminal may not get offline.

[0051] Optionally, after the terminal switches to the BWP indicated by the indication information, the terminal may further notify the base station that its BWP switching fails, and a corresponding process may be as follows: sending a BWP switching failure notification to the base station.

40 **[0052]** In implementation, after switching to the BWP indicated by the indication information, the terminal may obtain the control information of its own by demodulation, and then may send a BWP switching failure notification to the base station. After receiving the BWP switching failure notification sent by the terminal, the base station may send a BWP switching instruction to the terminal, with an identifier of the BWP to be switched to carried therein. After receiving the BWP switching instruction

sent by the base station, the terminal may perform the BWP switching again.

[0053] In the embodiments of the present disclosure, a terminal receives indication information sent by a base station, wherein the indication information is configured to indicate a standby BWP that is used when a BWP switching failure occurs, and the BWP indicated by the indication information is any of a BWP at which a terminal works currently, a BWP at which the terminal works previously, and preset BWP; the BWP indicated by the indication information is switched to when the BWP switching is detected to have failed; and control information corresponding to the terminal that is sent by the base station at the BWP indicated by the indication information is received. In this way, when the BWP switching failure occurs, the terminal may acquire control information corresponding to itself from the BWP indicated by the base station, leading to low possibility of getting offline by the terminal.

[0054] Based on the same technical idea, another exemplary embodiment of the present disclosure further provides a terminal, as shown in FIG. 4, which includes:

a first receiving module 410 configured to receive indication information sent by a base station, wherein the indication information is configured to indicate a BWP that is used when a BWP switching failure occurs, and the BWP indicated by the indication information is any of a BWP at which a terminal works currently, a BWP at which the terminal works previously, and preset BWP;

a switching module 420 configured to switch to the BWP indicated by the indication information when detecting that the BWP switching failure occurs; and a second receiving module 430 configured to receive control information corresponding to the terminal that is sent by the base station at the BWP indicated by the indication information.

[0055] The switching module 420 is configured to: switch to the BWP indicated by the indication information when a duration since last successful demodulation to the control information corresponding to the terminal reaches a first duration, wherein the first duration is a preset value, or a value computed based on a first reference duration, a BWP parameter corresponding to a pre-switching BWP, and a preset computing terminal.

[0056] The first receiving module 410 is further configured to:

receive configuration information of the first duration that is sent by the base station via a broadcast signaling, an upper-layer signaling, or a physical-layer signaling, wherein the configuration information includes the first reference duration and the preset computing terminal.

[0057] The first duration is expressed by a length of time, a number of unit time-domain resources, or a number of code block groups.

[0058] Optionally, as shown in FIG. 5, the terminal fur-

ther includes:

a sending module 440 configured to send a BWP switching failure notification to the base station.

[0059] In the embodiments of the present disclosure, a terminal receives indication information sent by a base station, wherein the indication information is configured to indicate a standby BWP that is used when a BWP switching failure occurs, and the BWP indicated by the indication information is any of a BWP at which a terminal works currently, a BWP at which the terminal works previously, and preset BWP; the BWP indicated by the indication information is switched to when the BWP switching is detected to have failed; and control information corresponding to the terminal that is sent by the base station at the BWP indicated by the indication information is received. In this way, when the BWP switching failure occurs, the terminal may acquire control information corresponding to itself from the BWP indicated by the base station, leading to low possibility of getting offline by the terminal.

[0060] It should be noted that the terminal provided by the present embodiment only takes division of all the functional modules as an example for explanation during acquiring of the control information. In practice, the above functions can be finished by the different functional modules as required. That is, the internal structure of the terminal is divided into different functional modules to finish all or part of the functions described above. In addition, the terminal provided by the present embodiment has the same concept as the method for acquiring control information provided by the foregoing embodiment. Refer to the method embodiment for the specific implementation process of the terminal, which will not be repeated herein.

[0061] Based on the same technical idea, another exemplary embodiment of the present disclosure further provides a base station, as shown in FIG. 6, which includes:

a first sending module 610 configured to send indication information to a terminal, wherein the indication information is configured to indicate a standby BWP that is used when the terminal has a BWP switching failure, and the BWP indicated by the indication information is any of a BWP at which the terminal works currently, a BWP at which the terminal works previously, and preset BWP; and a second sending module 620 configured to send control information corresponding to the terminal to the terminal at the BWP indicated by the indication information.

[0062] Optionally, the second sending module 620 is configured to:

send control information corresponding to the terminal to the terminal at the BWP indicated by the indication information when a BWP switching success notification sent by the terminal is not received within a third duration

after a BWP switching instruction is sent to the terminal.

[0063] Optionally, the second sending module 620 is further configured to:

stop sending the control information corresponding to the terminal to the terminal at the BWP indicated by the indication information when a BWP switching failure notification sent by the terminal is not received within a fourth duration after the control information corresponding to the terminal is sent to the terminal at the BWP indicated by the indication information.

[0064] In the embodiments of the present disclosure, a terminal receives indication information sent by a base station, wherein the indication information is configured to indicate a standby BWP that is used when a BWP switching failure occurs, and the BWP indicated by the indication information is any of a BWP at which a terminal works currently, a BWP at which the terminal works previously, and preset BWP; the BWP indicated by the indication information is switched to when the BWP switching is detected to have failed; and control information corresponding to the terminal that is sent by the base station at the BWP indicated by the indication information is received. In this way, when the BWP switching failure occurs, the terminal may acquire control information corresponding to itself from the BWP indicated by the base station, leading to low possibility of getting offline by the terminal.

[0065] It should be noted that the base station provided by the present embodiment only takes division of all the functional modules as an example for explanation during acquiring of the control information. In practice, the above functions can be finished by the different functional modules as required. That is, the internal structure of the base station is divided into different functional modules to finish all or part of the functions described above. In addition, the base station provided by the present embodiment has the same concept as the method for acquiring control information provided by the foregoing embodiment. Refer to the method embodiment for the specific implementation process of the base station, which will not be repeated herein.

[0066] A further exemplary embodiment of the present disclosure provides a schematic structural diagram of a terminal. The terminal may be a mobile phone and the like.

[0067] Referring to FIG. 7, the terminal 700 may include one or more of the following components: a processing component 702, a memory 704, a power component 706, a multimedia component 708, an audio component 710, an input/output (I/O) interface 712, a sensor component 714, and a communication component 716.

[0068] The processing component 702 typically controls the overall operations of the terminal 700, such as the operations associated with display, telephone calls, data communications, camera operations, and recording operations. The processing component 702 may include one or more processors 720 to execute instructions to

perform all or part of the steps in the above described methods. Moreover, the processing component 702 may include one or more modules which facilitate the interaction between the processing component 702 and other components. For instance, the processing component 702 may include a multimedia module to facilitate the interaction between the multimedia component 708 and the processing component 702.

[0069] The memory 704 is configured to store various types of data to support the operation of the terminal 700. Examples of such data include instructions for any applications or methods operated on the terminal 700, contact data, phonebook data, messages, pictures, videos, etc. The memory 704 may be implemented by using any type of volatile or non-volatile memory devices, or a combination thereof, such as a static random access memory (SRAM), an electrically erasable programmable read-only memory (EEPROM), an erasable programmable read-only memory (EPROM), a programmable read-only memory (PROM), a read-only memory (ROM), a magnetic memory, a flash memory, a magnetic or optical disk.

[0070] The power component 706 provides power to various components of the terminal 700. The power component 706 may include a power management system, one or more power sources, and any other components associated with the generation, management, and distribution of power in the terminal 700.

[0071] The multimedia component 708 includes a screen providing an output interface between the terminal 700 and the user. In some embodiments, the screen may include a liquid crystal display (LCD) and a touch panel (TP). If the screen includes the touch panel, the screen may be implemented as a touch screen to receive input signals from the user. The touch panel includes one or more touch sensors to sense touches, swipes, and gestures on the touch panel. The touch sensors may not only sense a boundary of a touch or swipe action, but also sense the duration and pressure associated with the touch or swipe action. In some embodiments, the multimedia component 708 includes a front camera and/or a rear camera. The front camera and the rear camera may receive external multimedia data while the terminal 700 is in an operation mode, such as a photographing mode or a video mode. Each of the front camera and the rear camera may be a fixed optical lens system or have focus and optical zoom capability.

[0072] The audio component 710 is configured to output and/or input audio signals. For example, the audio component 710 includes a microphone (MIC) configured to receive external audio signals when the terminal 700 is in an operation mode, such as a call mode, a recording mode, and a voice recognition mode. The received audio signal may be further stored in the memory 704 or transmitted via the communication component 716. In some embodiments, the audio component 710 further includes a speaker for outputting audio signals.

[0073] The I/O interface 712 provides an interface between the processing component 702 and peripheral in-

terface modules, such as a keyboard, a click wheel, buttons, and the like. The buttons may include, but are not limited to, a home button, a volume button, a start button, and a lock button.

[0074] The sensor component 714 includes one or more sensors to provide status assessments of various aspects of the terminal 700. For instance, the sensor component 714 may detect an on/off status of the terminal 700, relative positioning of components, e.g., the display device and the mini keyboard of the terminal 700, and the sensor component 714 may also detect a position change of the terminal 700 or a component of the terminal 700, presence or absence of user contact with the terminal 700, orientation or acceleration/deceleration of the terminal 700, and temperature change of the terminal 700. The sensor component 714 may include a proximity sensor configured to detect the presence of nearby objects without any physical contact. The sensor component 714 may also include a light sensor, such as a CMOS or CCD image sensor, used for imaging applications. In some embodiments, the sensor component 714 may also include an accelerometer sensor, a gyroscope sensor, a magnetic sensor, a pressure sensor, or a temperature sensor.

[0075] The communication component 716 is configured to facilitate communication, wired or wirelessly, between the terminal 700 and other devices. The terminal 700 can access a wireless network based on a communication standard, such as WiFi, 2G, or 3G, or a combination thereof. In an exemplary embodiment, the communication component 716 receives broadcast signals or broadcast associated information from an external broadcast management system via a broadcast channel. In an exemplary embodiment, the communication component 716 further includes a near field communication (NFC) module to facilitate short-range communications.

[0076] In exemplary embodiments, the terminal 700 may be implemented with one or more application specific integrated circuits (ASICs), digital signal processors (DSPs), digital signal processing devices (DSPDs), programmable logic devices (PLDs), field programmable gate arrays (FPGAs), controllers, micro-controllers, microprocessors, or other electronic components, for performing the above described methods.

[0077] In exemplary embodiments, a non-transitory computer-readable storage medium including instructions is also provided, such as the memory 704 including instructions, executable by the processor 720 in the terminal 700, for performing the above-described methods. For example, the non-transitory computer-readable storage medium may be a ROM, a RAM, a CD-ROM, a magnetic tape, a floppy disc, an optical data storage device, and the like.

[0078] There is provided a non-transitory computer readable storage medium. When instructions in the storage medium are executed by a processor of a terminal, the terminal is enabled to execute the method described above, which includes:

receiving indication information sent by a base station, wherein the indication information is configured to indicate a BWP that is used when a BWP switching failure occurs, and the BWP indicated by the indication information is any of a BWP at which a terminal works currently, a BWP at which the terminal works previously, and preset BWP; switching to the BWP indicated by the indication information when detecting that the BWP switching failure occurs; and receiving control information corresponding to the terminal that is sent by the base station at the BWP indicated by the indication information.

[0079] The switching to the BWP indicated by the indication information when detecting that the BWP switching failure occurs includes:

switching to the BWP indicated by the indication information when a duration since last successful demodulation to the control information corresponding to the terminal reaches a first duration, wherein the first duration is a preset value, or a value computed based on a first reference duration, a BWP parameter corresponding to a pre-switching BWP, and a preset computing method.

[0080] The method further includes: receiving configuration information of the first duration that is sent by the base station via a broadcast signaling, an upper-layer signaling, or a physical-layer signaling, wherein the configuration information includes the first reference duration and the preset computing method.

[0081] The first duration is expressed by a length of time, a number of unit time-domain resources, or a number of code block groups.

[0082] Optionally, the receiving control information corresponding to the terminal that is sent by the base station at the BWP indicated by the indication information further includes:

sending a BWP switching failure notification to the base station.

[0083] In the embodiments of the present disclosure, a terminal receives indication information sent by a base station, wherein the indication information is configured to indicate a standby BWP that is used when a BWP switching failure occurs, and the BWP indicated by the indication information is any of a BWP at which a terminal works currently, a BWP at which the terminal works previously, and preset BWP; the BWP indicated by the indication information is switched to when the BWP switching is detected to have failed; and control information corresponding to the terminal that is sent by the base station at the BWP indicated by the indication information is received. In this way, when the BWP switching failure occurs, the terminal may acquire control information corresponding to itself from the BWP indicated by the base station, leading to low possibility of getting offline by the terminal.

[0084] Persons of ordinary skills in the art may understand that all or some of the steps described in the em-

bodiments above can be completed through hardware, or through relevant software instructed by a program stored in a non-transitory computer readable storage medium, and the storage medium mentioned above may be a read-only memory, a disk or a CD, or the like.

[0085] The foregoing descriptions are merely preferred embodiments of the present disclosure, and are not intended to limit the present disclosure, the scope of the invention is however defined by the appended claims.

Claims

1. A method for acquiring control information, performed by a terminal, the method comprises: receiving control information corresponding to the terminal sent by a base station in a bandwidth part, BWP, at which the terminal works currently; the method being **characterized in that** it further comprises:

receiving (202) indication information sent by the base station, wherein the indication information is configured to indicate a standby bandwidth part, BWP, that is used when a BWP switching failure occurs, and the standby BWP indicated by the indication information is any of the BWP at which a terminal works currently, a BWP at which the terminal worked previously, and a preset BWP;

switching (203) to the standby BWP indicated by the indication information when detecting that the BWP switching failure occurs; and receiving (205) control information corresponding to the terminal that is sent by the base station at the standby BWP indicated by the indication information,

wherein the switching (203) to the standby BWP indicated by the indication information when detecting that the BWP switching failure occurs comprises:

switching to the standby BWP indicated by the indication information when a duration since last successful demodulation to the control information corresponding to the terminal reaches a first duration,

wherein the method further comprises:

receiving configuration information of the first duration that is sent by the base station via a broadcast signaling, an upper-layer signaling, or a physical-layer signaling.

2. The method according to claim 1, **characterized in that**, the first duration is a preset value, or a value computed based on a first reference duration, a BWP parameter corresponding to a pre-switching BWP, and a preset computing method, wherein the config-

uration information comprises the first reference duration and the preset computing method.

3. The method according to claim 1 or 2, **characterized in that**, the first duration is expressed by a length of time, a number of unit time-domain resources, or a number of code block groups.

4. The method according to claim 1, **characterized in that**, after the receiving (202) control information corresponding to the terminal that is sent by the base station at the standby BWP indicated by the indication information, the method further comprises:

sending a BWP switching failure notification to the base station.

5. A method for acquiring control information, performed by a base station, the method comprises: sending control information corresponding to a terminal to the terminal in a

bandwidth part, BWP, at which the terminal works currently; the method being **characterized in that** it further comprises:

sending (201) indication information to the terminal, wherein the indication information is configured to indicate a standby BWP that is used when the terminal has a BWP switching failure, and the standby BWP indicated by the indication information is any of a BWP at which the terminal works currently, a BWP at which the terminal worked previously, and a preset BWP; sending a switching instruction to the terminal; and

sending (204) control information corresponding to the terminal to the terminal at the standby BWP indicated by the indication information, wherein the method further comprises:

sending configuration information of a first duration to the terminal via a broadcast signaling, an upper-layer signaling, or a physical-layer signaling, wherein the first duration is for determining a BWP switching failure at the terminal when a duration since last successful demodulation to the control information corresponding to the terminal reaches the first duration.

6. The method according to claim 5, **characterized in that**, the sending (204) control information corresponding to the terminal to the terminal at the standby BWP indicated by the indication information comprises:

sending control information corresponding to the terminal to the terminal at the standby BWP indicated by the indication information when a BWP switching success notification sent by the terminal is not received within a third duration after a BWP switching instruction is sent to the terminal.

7. The method according to claim 6, **characterized in that**, after the sending (204) control information corresponding to the terminal to the terminal at the standby BWP indicated by the indication information, the method further comprises:
- 5 stopping sending the control information corresponding to the terminal to the terminal at the standby BWP indicated by the indication information when a BWP switching failure notification sent by the terminal is not received within a fourth duration after the control information corresponding to the terminal is sent to the terminal at the standby BWP indicated by the indication information.
- 10
8. A terminal, comprising a processor and a memory, wherein the memory stores at least one instruction, at least one program, a code set, or an instruction set, wherein when the at least one instruction, the at least one program, the code set or the instruction set is loaded and executed by the processor, the terminal is enabled to implement the method for acquiring control information according to any one of claims 1 to 4.
- 15
- 20
- 25

Patentansprüche

1. Verfahren zur Erfassung von Steuerinformationen, das von einem Terminal durchgeführt wird, wobei das Verfahren umfasst:
- Empfangen von dem Terminal entsprechenden Steuerinformationen, die von einer Basisstation in einem Bandbreitenteil, BWP, gesendet werden, in dem das Terminal gerade arbeitet, wobei das Verfahren **dadurch gekennzeichnet ist, dass** es ferner umfasst:
- Empfangen (202) von Anzeigedaten, die von der Basisstation gesendet werden, wobei die Anzeigedaten so konfiguriert sind, dass sie einen Standby Bandbreitenteil, BWP, anzeigen, der verwendet wird, wenn ein BWP-Umschaltfehler auftritt, und der Standby-BWP, der durch die Anzeigedaten angezeigt wird, entweder der BWP ist, mit dem ein Terminal derzeit arbeitet, oder ein BWP, mit dem das Terminal zuvor gearbeitet hat, und ein voreingestellter BWP ist; Umschalten (203) auf den Standby-BWP, der durch die Anzeigeinformation angezeigt wird, wenn festgestellt wird, dass der BWP-Umschaltfehler auftritt; und
- Empfangen (205) von Steuerinformationen, die dem Terminal entsprechen, das von der Basisstation an dem durch die Anzeigeinformationen angegebenen Standby-BWP gesendet wird, wobei das Umschalten (203) auf den Standby-BWP, das durch die Anzeigeinformation angezeigt wird, wenn festgestellt wird, dass der BWP-
- 30
- 35
- 40
- 45
- 50
- 55

Umschaltfehler auftritt, umfasst:

- Umschalten auf den durch die Anzeigeinformation angegebenen Standby-BWP, wenn eine Dauer seit der letzten erfolgreichen Demodulation der dem Terminal entsprechenden Steuerinformation eine erste Dauer erreicht, wobei das Verfahren ferner umfasst: Empfangen von Konfigurationsinformationen der ersten Dauer, die von der Basisstation über eine Broadcast-Signalisierung, eine Signalisierung der oberen Schicht oder eine Signalisierung der physikalischen Schicht gesendet werden.
2. Verfahren nach Anspruch 1, **dadurch gekennzeichnet, dass** die erste Dauer ein voreingestellter Wert oder ein Wert ist, der auf der Grundlage einer ersten Referenzdauer, eines BWP-Parameters, der einem Vorschaltungs-BWP entspricht, und eines voreingestellten Berechnungsverfahrens berechnet wird, wobei die Konfigurationsinformationen die erste Referenzdauer und das voreingestellte Berechnungsverfahren umfassen.
3. Verfahren nach Anspruch 1 oder 2, **dadurch gekennzeichnet, dass** die erste Dauer durch eine Zeitspanne, eine Anzahl von Zeitbereichsressourcen oder eine Anzahl von Codeblockgruppen ausgedrückt wird.
4. Verfahren nach Anspruch 1, **dadurch gekennzeichnet, dass** nach dem Empfang (202) von Steuerinformationen, die dem Terminal entsprechen, das von der Basisstation mit dem durch die Anzeigeinformationen angegebenen Standby-BWP gesendet wird, das Verfahren ferner umfasst: Senden einer Benachrichtigung über einen BWP-Umschaltfehler an die Basisstation.
5. Verfahren zur Erfassung von Steuerinformationen, das von einer Basisstation durchgeführt wird, wobei das Verfahren umfasst: Senden von Steuerinformationen, die einem Terminal entsprechen, an das Terminal in einem Bandbreitenteil, BWP, in dem das Terminal gerade arbeitet; wobei das Verfahren **dadurch gekennzeichnet ist, dass** es ferner umfasst:
- Senden (201) von Anzeigedaten an das Terminal, wobei die Anzeigedaten so konfiguriert sind, dass sie einen Standby-BWP anzeigen, der verwendet wird, wenn das Terminal einen BWP-Umschaltfehler hat, und der durch die Anzeigedaten angezeigte Standby-BWP entweder ein BWP ist, mit dem das Terminal derzeit arbeitet,

oder ein BWP, mit dem das Terminal zuvor gearbeitet hat, oder ein voreingestellter BWP ist; Senden einer Umschaltanweisung an das Terminal; und

Senden (204) von Steuerinformationen, die dem Terminal entsprechen, an das Terminal mit dem Standby-BWP, das durch die Anzeigeeinformationen angegeben wird,

wobei das Verfahren ferner umfasst:

Senden von Konfigurationsinformationen einer ersten Dauer an das Terminal über eine Broadcast-Signalisierung, eine Signalisierung der oberen Schicht oder eine Signalisierung der physikalischen Schicht, wobei die erste Dauer dazu dient, einen BWP-Umschaltfehler an dem Terminal zu bestimmen, wenn eine Dauer seit der letzten erfolgreichen Demodulation der dem Terminal entsprechenden Steuerinformationen die erste Dauer erreicht.

6. Verfahren nach Anspruch 5, **dadurch gekennzeichnet, dass** das Senden (204) von Steuerinformationen, die dem Terminal entsprechen, an das Terminal am Standby-BWP, das durch die Anzeigeeinformationen angegeben wird, umfasst:

Senden von Steuerinformationen, die dem Terminal entsprechen, an das Terminal am Standby-BWP, der durch die Anzeigeeinformationen angezeigt wird, wenn eine vom Terminal gesendete BWP-Umschalt-Erfolgsmeldung nicht innerhalb einer dritten Dauer nach dem Senden einer BWP-Umschaltanweisung an das Terminal empfangen wird.

7. Verfahren nach Anspruch 6, **dadurch gekennzeichnet, dass** das Verfahren nach dem Senden (204) von Steuerinformationen, die dem Terminal entsprechen, an das Terminal am Standby-BWP, der durch die Anzeigeeinformationen angegeben wird, ferner umfasst:

Beenden des Sendens der dem Terminal entsprechenden Steuerinformationen an das Terminal mit dem durch die Anzeigedaten angegebenen Standby-BWP, wenn eine von dem Terminal gesendete Benachrichtigung über einen BWP-Umschaltfehler nicht innerhalb einer vierten Dauer nach dem Senden der dem Terminal entsprechenden Steuerinformationen an das Terminal mit dem durch die Anzeigedaten angegebenen Standby-BWP empfangen wird.

8. Terminal mit einem Prozessor und einem Speicher, wobei der Speicher mindestens einen Befehl, mindestens ein Programm, einen Codesatz oder einen Befehlsatz speichert, wobei, wenn der mindestens eine Befehl, das mindestens eine Programm, der Codesatz oder der Befehlsatz durch den Prozessor geladen und ausgeführt wird, das Terminal in die Lage versetzt wird, das Verfahren zum Erfassen von

Steuerinformationen nach einem der Ansprüche 1 bis 4 zu implementieren.

5 Revendications

1. Méthode d'acquisition d'informations de contrôle, exécutée par un terminal, la méthode comprenant : recevoir des informations de contrôle correspondant au terminal qui sont émises par une station de base dans une partie de la bande passante, BWP, à laquelle le terminal travaille actuellement ; le procédé est **caractérisé en ce qu'il** comprend en outre :

réception (202) d'informations d'indication envoyées par la station de base, les informations d'indication étant configurées pour indiquer une partie de la largeur de bande en attente, BWP, qui est utilisée lorsqu'une défaillance de commutation BWP se produit, et la BWP en attente indiquée par les informations d'indication est l'une quelconque de la BWP à laquelle un terminal travaille actuellement, une BWP à laquelle le terminal travaillait précédemment, et une BWP prédéfinie ;

commutation (203) vers le BWP de réserve indiqué par l'information d'indication lors de la détection de l'échec de la commutation BWP ; et réception (205) de l'information de contrôle correspondant au terminal envoyé par la station de base au BWP en attente indiqué par l'information d'indication, dans lequel la commutation (203) vers le BWP de réserve indiqué par l'information d'indication lors de la détection de l'échec de la commutation BWP comprend :

passer au BWP d'attente indiqué par l'information d'indication lorsque la durée écoulée depuis la dernière démodulation réussie de l'information de contrôle correspondant au terminal atteint une première durée, dans laquelle la méthode comprend en outre

réception des informations de configuration de la première durée envoyées par la station de base via une signalisation de diffusion, une signalisation de couche supérieure ou une signalisation de couche physique.

2. La méthode selon la revendication 1, **caractérisée par le fait que** la première durée est une valeur prédéfinie, ou une valeur calculée sur la base d'une première durée de référence, d'un paramètre BWP correspondant à un BWP de pré-commutation, et d'une méthode de calcul prédéfinie, dans laquelle les informations de configuration comprennent la première durée de référence et la méthode de calcul

prédéfinie.

3. La méthode selon la revendication 1 ou 2, **caractérisée par le fait que** la première durée est exprimée par une longueur de temps, un nombre de ressources temporelles unitaires ou un nombre de groupes de blocs de code. 5
4. La méthode selon la revendication 1, **caractérisé en ce que**, après la réception (202) de l'information de contrôle correspondant au terminal qui est envoyé par la station de base au BWP d'attente indiqué par l'information d'indication, la méthode comprend en outre :
envoyer une notification d'échec de commutation BWP à la station de base. 10 15
5. La méthode d'acquisition d'informations de contrôle, exécutée par une station de base, la méthode comprenant :
envoyer des informations de contrôle correspondant à un terminal au terminal dans une partie de la bande passante, BWP, à laquelle le terminal travaille actuellement ; la méthode est **caractérisé en ce qu'elle** comprend en outre :
envoyer (201) des informations d'indication au terminal, dans lesquelles les informations d'indication sont configurées pour indiquer un BWP de réserve qui est utilisé lorsque le terminal a un échec de commutation BWP, et le BWP de réserve indiqué par les informations d'indication est n'importe lequel d'un BWP auquel le terminal travaille actuellement, d'un BWP auquel le terminal a travaillé précédemment, et d'un BWP prédéfini ; envoyer une instruction de commutation au terminal ; et
envoyer (204) l'information de contrôle correspondant au terminal au BWP en attente indiqué par l'information d'indication,
dans laquelle la méthode comprend en outre
envoyer des informations de configuration d'une première durée au terminal via une signalisation de diffusion, une signalisation de couche supérieure ou une signalisation de couche physique, la première durée servant à déterminer une défaillance de commutation BWP au niveau du terminal lorsque la durée écoulée depuis la dernière démodulation réussie des informations de contrôle correspondant au terminal atteint la première durée. 20 25 30 35 40 45 50
6. La méthode selon la revendication 5, **caractérisé en ce que** l'envoi (204) d'une information de contrôle correspondant au terminal au BWP d'attente indiqué par l'information d'indication comprend :
envoyer des informations de contrôle correspondant au terminal au BWP d'attente indiqué par les infor-

mations d'indication lorsqu'une notification de réussite du changement de BWP envoyée par le terminal n'est pas reçue dans un troisième délai après l'envoi d'une instruction de changement de BWP au terminal.

7. La méthode selon la revendication 6, **caractérisé en ce que**, après l'envoi (204) de l'information de contrôle correspondant au terminal au BWP d'attente indiqué par l'information d'indication, la méthode comprend en outre :
arrêter d'envoyer l'information de contrôle correspondant au terminal au BWP de réserve indiqué par l'information d'indication lorsqu'une notification d'échec de commutation BWP envoyée par le terminal n'est pas reçue dans un quatrième délai après l'envoi de l'information de contrôle correspondant au terminal au BWP de réserve indiqué par l'information d'indication.
8. Terminal comprenant un processeur et une mémoire, dans lequel la mémoire stocke au moins une instruction, au moins un programme, un ensemble de codes ou un ensemble d'instructions, dans lequel, lorsque l'au moins une instruction, l'au moins un programme, l'ensemble de codes ou l'ensemble d'instructions est chargé et exécuté par le processeur, le terminal est en mesure de mettre en oeuvre la méthode d'acquisition d'informations de contrôle selon l'une quelconque des revendications 1 à 4. 55

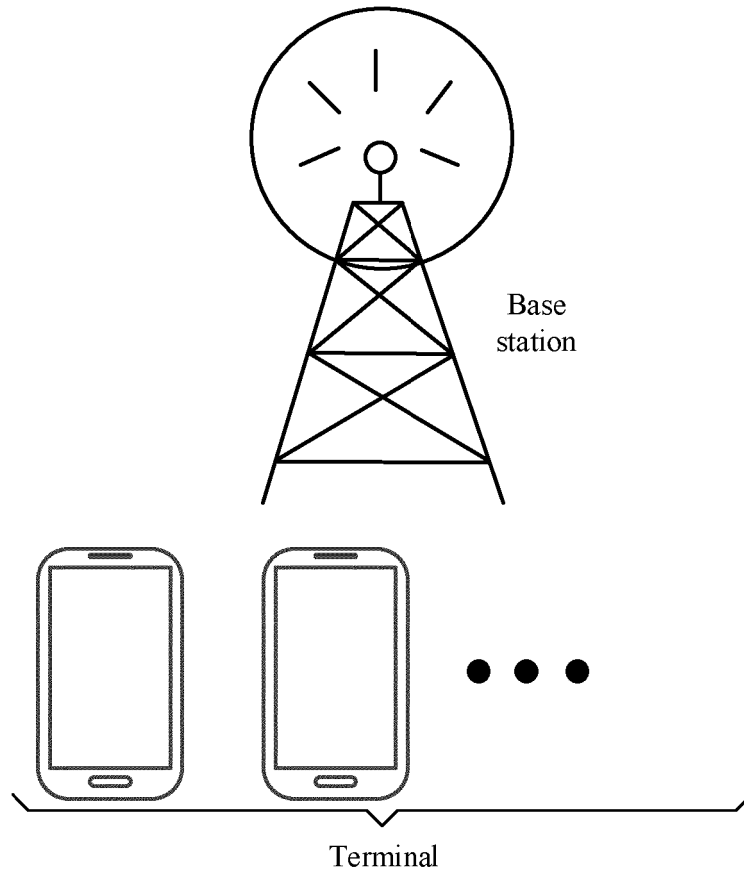

FIG. 1

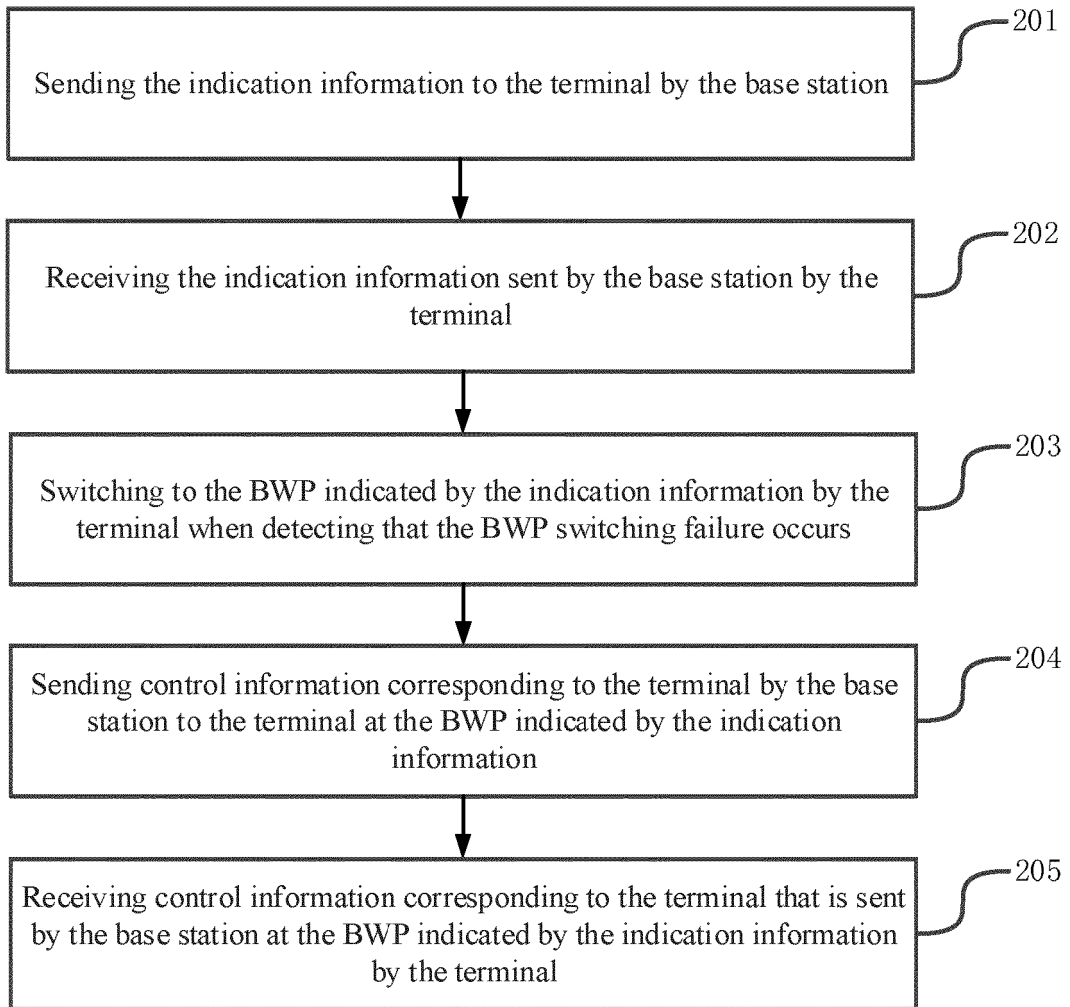

FIG. 2

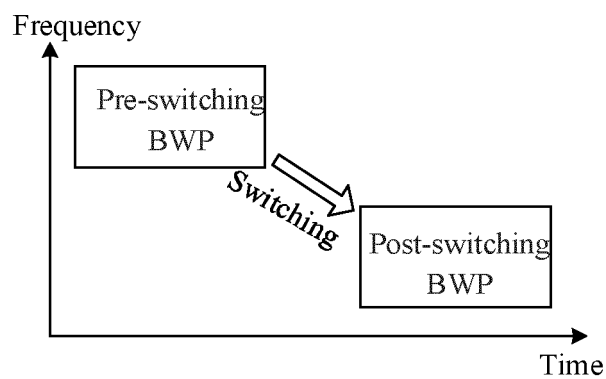

FIG. 3

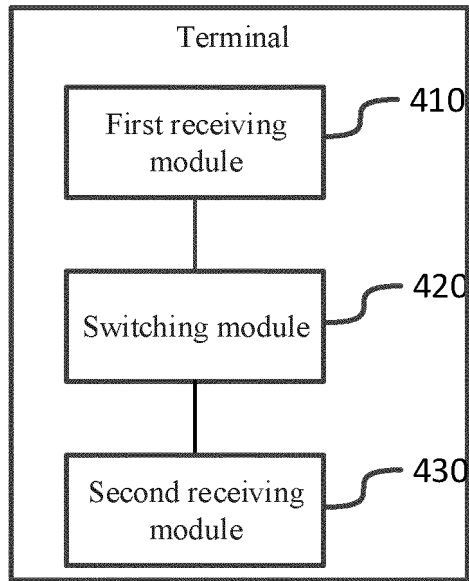

FIG. 4

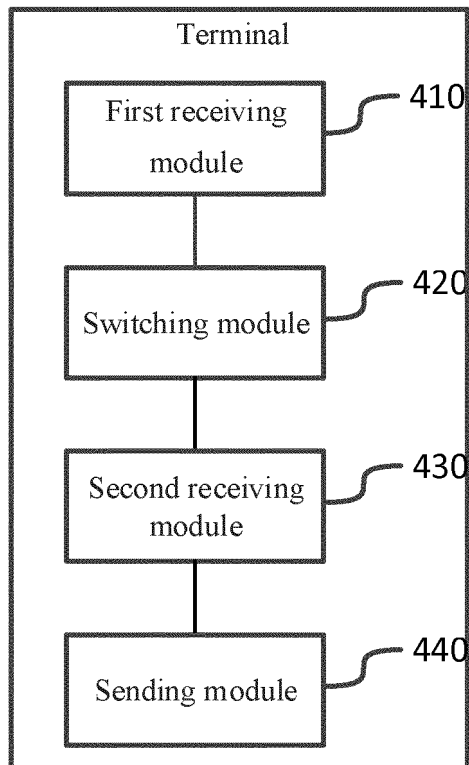

FIG. 5

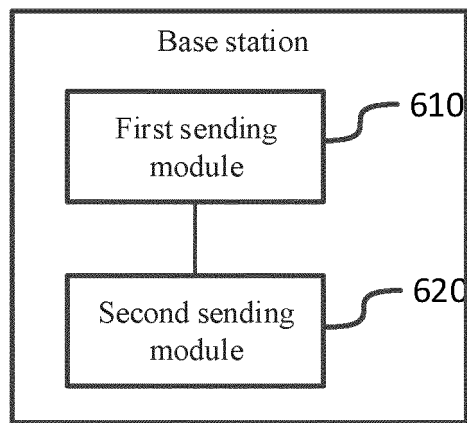

FIG. 6

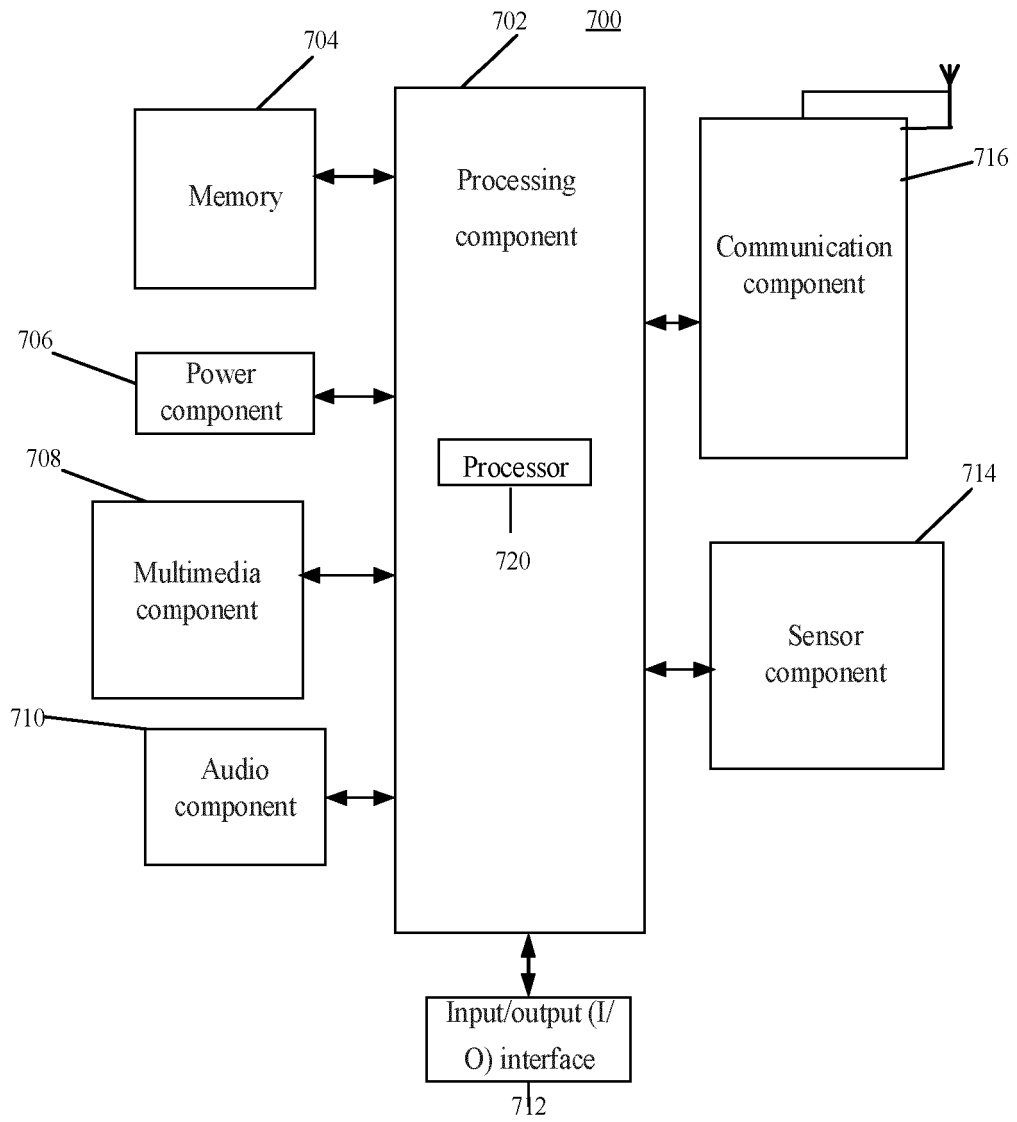

FIG. 7

REFERENCES CITED IN THE DESCRIPTION

This list of references cited by the applicant is for the reader's convenience only. It does not form part of the European patent document. Even though great care has been taken in compiling the references, errors or omissions cannot be excluded and the EPO disclaims all liability in this regard.

Patent documents cited in the description

- US 20110026475 A1 [0004]
- WO 2010050887 A1 [0005]

Non-patent literature cited in the description

- **HUAWEI et al.** Bandwidth adaptation and scalable design in NR. *3GPP DRAFT: R1-1701644* [0006]