

A. M. CARLSEN.  
Calendar-Clock.

No. 209,458.

Patented Oct. 29, 1878.

Fig 1.

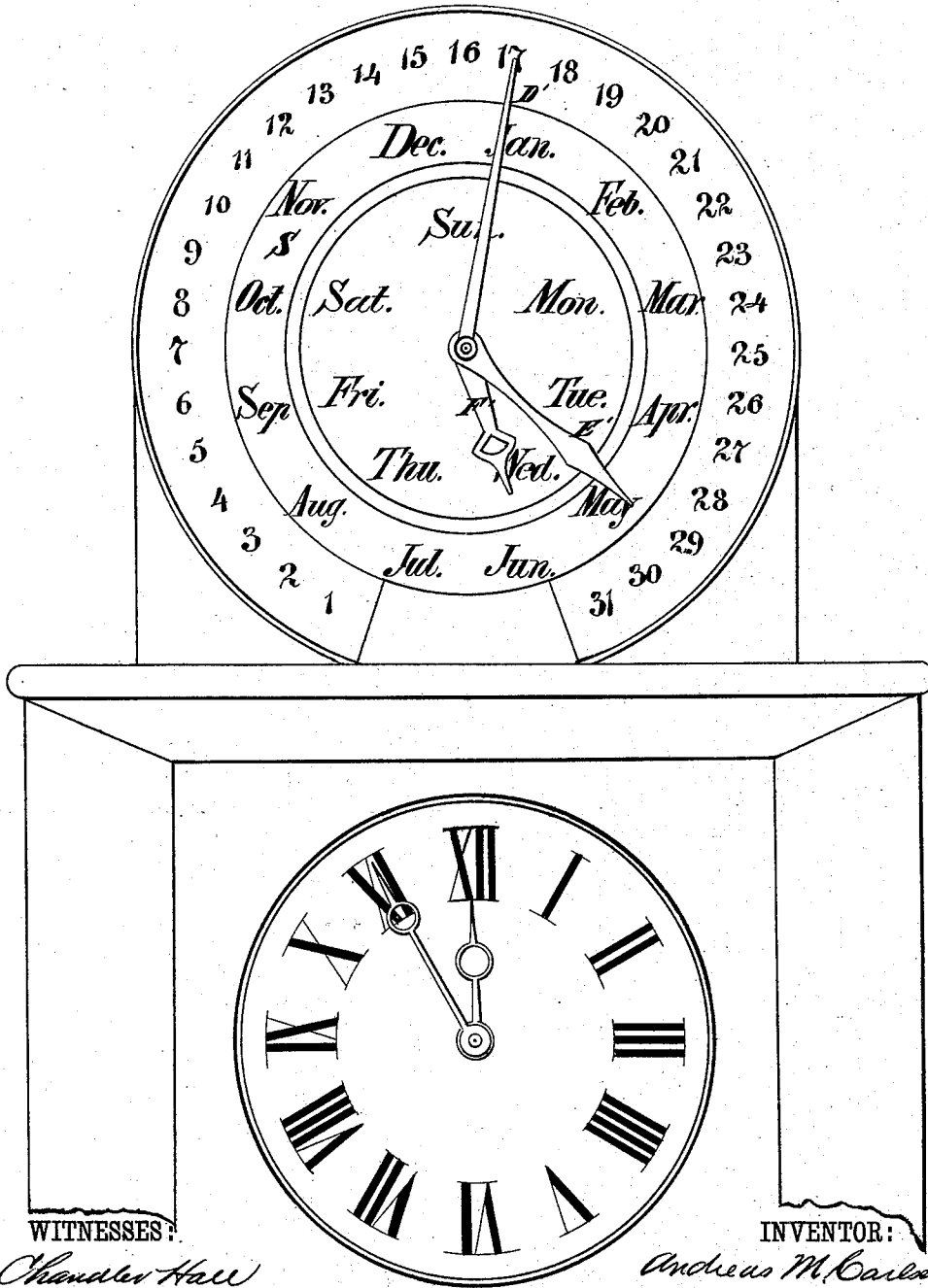

WITNESSES:

*Chandler Hall*  
*Thomas E. Birch*

INVENTOR:

*Andreas M. Carlsen*  
*by his attorney,*  
*Edwin H. Brown*

A. M. CARLSEN.  
Calendar-Clock.

No. 209,458.

Patented Oct. 29, 1878.

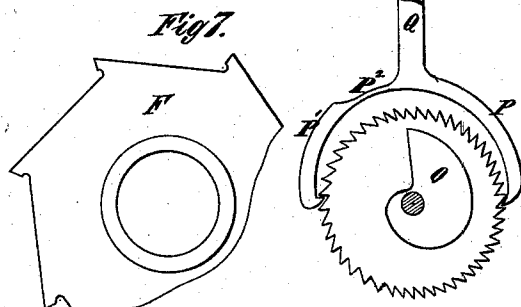
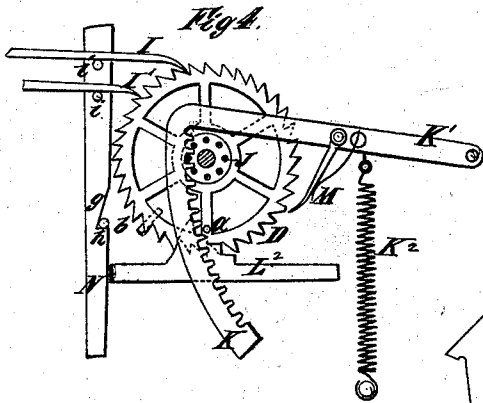
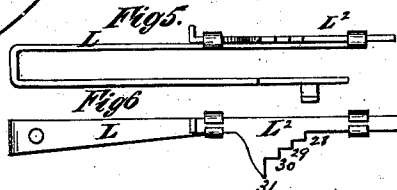
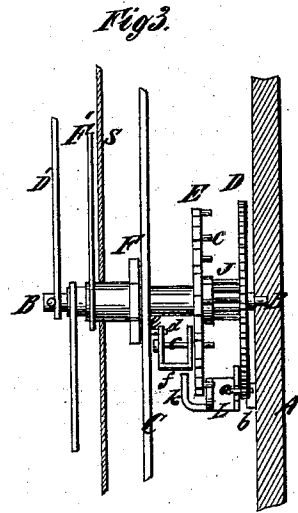
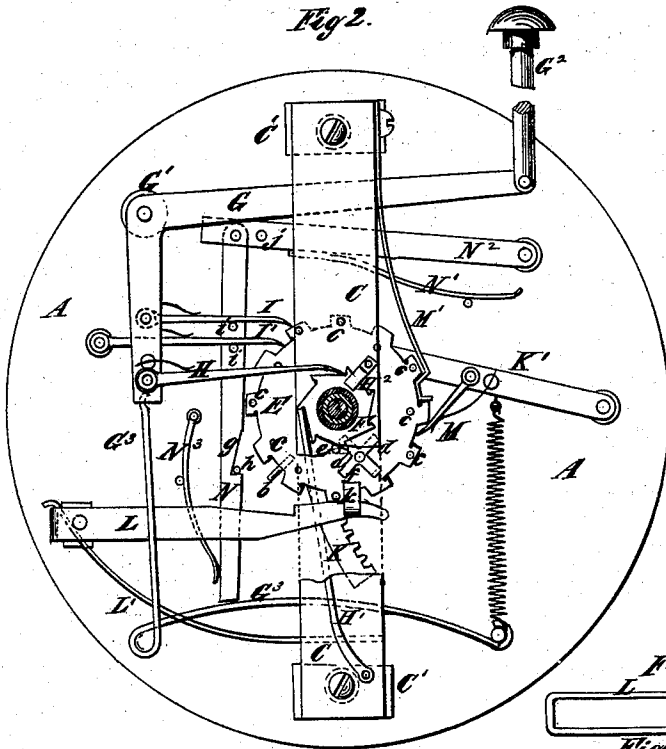

Witnesses:  
Chandler Hall  
Thomas E. Birch

Inventor:  
Andreas M. Carlsen  
by his Attorney,  
Edwin M. Brown

# UNITED STATES PATENT OFFICE.

ANDREAS M. CARLSEN, OF BROOKLYN, NEW YORK.

## IMPROVEMENT IN CALENDAR-CLOCKS.

Specification forming part of Letters Patent No. 209,458, dated October 29, 1878; application filed September 3, 1878.

*To all whom it may concern:*

Be it known that I, ANDREAS M. CARLSEN, of Brooklyn, in Kings county, and State of New York, have invented certain new and useful Improvements in Calendar-Instruments, of which the following is a specification:

The object of my invention is to produce a simple, cheap, and perfect calendar-instrument, adapted to be operated either by hand or a clock.

To this end my invention consists in various combinations of parts; whereby the desired end is attained.

In the accompanying drawing, Figure 1 shows a face view of my calendar-instrument combined with a clock. Fig. 2 is a front view of said calendar-instrument. Fig. 3 is a side view of certain portions of said instrument; and Figs. 4, 5, 6, 7, 8, 9, and 10 are detail views of such instrument.

Similar letters of reference designate corresponding parts in all the figures.

A designates a stock piece or support, to which the operative parts of the instrument are secured, and which may be of circular or any other suitable form. B designates a shaft or arbor, supported at the rear end by the stock-piece and at the front by a cross-piece, C, secured near the ends to pillars or standards C'. This shaft or arbor has affixed to it near the stock-piece what I term a "date-wheel," D, because through its instrumentality the date of days or their numbers in months is indicated. On the said shaft or arbor is a loose sleeve, carrying what I term a "month-wheel," E, because through its instrumentality the names of months are indicated. Also, on the shaft or arbor, in the present instance outside the cross-piece C, is a loose sleeve, carrying what I term the "day-wheel" F, because it serves to indicate the names of days.

G designates the prime mover of the instrument, consisting of a bell-crank lever pivoted at the junction of its arms to a pillar or boss, G<sup>1</sup>, close to the stock-piece A, and actuated by a downward push through a push-piece, G<sup>2</sup>, connected to it, and extending outward to where it may be operated by hand or through a clock, and caused to resume its normal position by means of a spring, G<sup>3</sup>.

As the mechanism for operating the day-

wheel is very simple, I will describe it first. The lower end of the prime mover G is bent forward toward the dial and turned upward so as to support a pawl, H, which engages with the teeth—seven in number—of the day-wheel F, it being held in engagement by a spring. Every time the prime mover is depressed the pawl H plays over the periphery of the wheel, and, dropping into a tooth, forces the wheel forward as the prime mover resumes its normal position, and through a finger, F', having a tooth or spline interlocked into the day-wheel sleeve, indicates upon the dial S of the instrument the names of the days. H<sup>1</sup> is a stop-pawl engaging with the day-wheel to preclude its backward movement. H<sup>2</sup> is a finger projecting over the front of the wheel to preclude it from working forward.

Turning now to a consideration of the operation of the date-wheel D, which must have at least thirty-two teeth, I designates a pawl carried by the downwardly-extending arms of the prime mover G, and held in engagement with the teeth of the date-wheel by means of a suitable spring, so that when the prime mover is depressed it plays over a tooth, and when the prime mover resumes its normal position forces the wheel forward one tooth. I' is a stop-pawl pivoted to the stock-piece A, held in engagement with this wheel by a suitable spring. A finger, D', shown as fitted on an angular boss at the end of the shaft or arbor B, indicates the dates of days on the dial S. In front of the date-wheel is a gear or trundle wheel, J, (see Figs. 3 and 4,) which engages with a toothed sector, K, extending from a lever, K<sup>1</sup>. Hence, as the date-wheel is forced round by the pawl I the lever K<sup>1</sup> is swung upward against the resistance of a spring, K<sup>2</sup>, and when the date-wheel D has completed its oscillation, so as to cause the date-finger D' to travel around the dial S to the proper stopping-place, and the pawl I and the stop-pawl I' are disengaged from the said wheel, the spring K<sup>2</sup>, acting upon the lever K<sup>1</sup>, forces the sector K downward and oscillates the date-wheel back to the starting-point, setting the date-finger D' at No. 1 on the dial S. At the end of its backward oscillation a pin, a, projecting both forwardly and rearwardly from it, comes in contact with a stop, b, on the stock-piece, and the wheel is

stopped. While the sector K and lever K<sup>1</sup> are rising a pawl, M, for actuating the month-wheel, plays over the next tooth rearward, a stop-pawl, M', holding the wheel meanwhile, and on the descent of the sector and lever the month-wheel is, by the pawl M, advanced a tooth.

Turning to the month-wheel E, as is now necessary to a clear understanding of the manner in which the mechanism just described is actuated, I would observe that this wheel has twelve nearly parallelogrammic teeth, preferably having rounded notches at the base of their fronts, and pins *c* projecting from their rear or back sides. These pins *c* are arranged at different distances from the periphery of the teeth, certain of them arranged on those teeth which relate to months having thirty-one days being quite close to the periphery of the teeth from which they project, certain others arranged on those teeth which relate to months having thirty days being farther from the periphery of the teeth from which they project, and the one arranged on the tooth relating to February being very much farther from the periphery of its tooth, and carrying on the front of the wheel a device adapting the tooth for February in leap-year as well as at other times. This device consists of a secondary wheel composed of four arms, *d*, pivoted loosely on said pin, and severally coming in contact, one in every revolution of the month-wheel E, with a pin, *e*, projecting rearwardly from the cross-piece C, so that each time the month-wheel revolves the secondary wheel is turned a quarter around. From one of the arms *d* of said wheel extends a bridge or extension, *f*, parallel with its supporting-pin *c*, and once in every four revolutions of the month-wheel—or, in other words, once in every four years—the bridge or extension projects downward. The inner end of said extension may be bent parallel with the month-wheel, and so as to be contiguous thereto and form a friction-spring for holding the secondary wheel, of which it forms part, in position.

The pins *c* of the month-wheel E operate on the lever L, composed of two parallel arms, pivoted near one end to a pillar or boss projecting from the stock-piece A, and impelled upward by a spring, L'. Fig. 5 is a plan or top view of this lever, and Fig. 6 a view of the rear side of said lever in an inverted position. The pins *c* impinge upon the upper face of the outer arm of the lever L, near the free end, and, according as they are distant from the periphery of the teeth of the month-wheel, depress the lever more or less. The rear arm of the lever L carries a slide-piece, L<sup>2</sup>, capable of adjustment longitudinally, and provided with a series of notches or steps 28 29 30 31. According as the lever is depressed, so is this slide-piece lowered and its notches severally presented to the forwardly-projecting portion of the pin *a* on the date-wheel. (See Figs. 3 and 4.) For example, a pin, *c*, far from the

periphery of its tooth, will permit the lever to rise so that the notch 28 will be presented to the pin *a*; if the bridge *f* of the secondary wheel or leap-year attachment be downward, the lever will be depressed so as to present notch 29 to the pin *a*; if one of the pins nearer the periphery of its tooth comes in contact with the lever, the latter will be depressed so as to present notch 30 to the pin *a*; or if one of the pins nearest the periphery of the tooth comes in contact with the lever, the latter will be so depressed as to present notch 31 to the pin *a*. Whenever the pin *a* comes in contact with any one of these notches in the slide-piece L<sup>2</sup>, the further passage of the date-finger D' over the dial S is precluded, save as may be necessary for its automatic resetting; hence it will be seen that the travel of this finger is regulated for months of different days; and even for February in a leap-year. After a contact of the pin *a* on the date-wheel with any notch of the slide-piece L<sup>2</sup>, the next movement of the prime mover forces back the slide-piece along the lever L, so as to bring its rear end in contact with a rod, N, and swing or throw the latter sidewise. This rod has a notch, *g*, with which it is provided, and which is thereby disengaged from a stop or pin, *h*, and it is immediately drawn upward by means of a spring, N<sup>1</sup>, acting on a lever, N<sup>2</sup>, to which the rod N is connected, and through two pins, *i*, with which it is furnished, lifts the pawls I I', disengaging them from the date-wheel, and permits it and the date-finger to be reversed by the sector K and spring K<sup>2</sup>. The next time the prime mover is depressed it forces down the lever N<sup>2</sup> by coming in contact with a pin, *j*, thereon, and depresses the rod N, whereupon a spring, N<sup>3</sup>, swings the said rod sidewise, so as to cause the notch *g* of said rod to engage with the pin *h*.

The fingers of this instrument may be set at pleasure, except in moving the date-hand from 1 to 2.

When once in a century leap-year's day is omitted this instrument may be set right by adjusting the date-finger to the next higher date.

In Fig. 10 I have represented devices for transmitting motion from a clock to the prime mover, consisting of an eccentric, O, for impinging against the prime mover or its push-piece, and a ratchet-wheel intended to have forty-eight teeth, operated by pawls P P<sup>1</sup> attached to a rod, Q. The pawl P<sup>1</sup> has its arm thinned to form a spring, P<sup>2</sup>, whereby both pawls are kept in contact with the ratchet-wheel, one operating the latter on the down-stroke and one on the upstroke. This rod is to be connected to a small crank on the back end of the clock shaft or arbor carrying the minute-hand. Thus the prime mover would be actuated once in every twenty-four hours.

Of course, this is only one of many ways of working the calendar-instrument, and may be modified at pleasure.

It will be seen that by my invention I pro-

duce a very simple, cheap, and perfect calendar-instrument.

What I claim as my invention, and desire to secure by Letters Patent, is—

1. In a calendar-instrument, the combination, with an oscillating date-wheel, of a gear or trundle wheel carried thereby, a toothed sector engaging therewith, and a spring for actuating such sector, substantially as specified.

2. In a calendar-instrument, the combination of an oscillating date-wheel, pawls for actuating the same, a gear-wheel and sector for effecting the return or reverse motion of the date-wheel, and means for releasing the pawls from the date-wheel, substantially as specified.

3. In a calendar-instrument, the combination of a month-wheel provided with teeth and a corresponding number of pins arranged at different distances from the periphery of the teeth, a lever actuated by said pins and carrying steps or notches of different projection, whereby the date-wheel and finger may be stopped through the month-wheel at the proper time to indicate the dates of days of various months, substantially as specified.

4. In a calendar-instrument, a month-wheel carrying a secondary wheel or a series of arms—four in number—one carrying an ex-

tension or bridge piece for acting through a lever on the date-wheel and finger so as to provide for automatically indicating the twenty-ninth day of February in leap-years.

5. In a calendar-instrument, the combination, with an oscillating date-wheel, a gear-wheel or trundle carried thereby, a toothed sector engaging with said gear-wheel or trundle and connected with a lever, and a spring for actuating said sector, of a month-wheel, a pawl carried by the sector-lever and actuating said month-wheel, and preferably, also, a stop-pawl engaging with said month-wheel, substantially as specified.

6. In a calendar-instrument, the combination of a month-wheel provided with teeth and a corresponding number of pins arranged at different distances from the periphery of the teeth, a lever actuated by said pins and carrying an adjustable slide-piece provided with steps or notches of different projection, whereby the date-wheel and finger may be stopped through the month-wheel at the proper time to indicate the dates of days of various months, substantially as specified.

ANDREAS M. CARLSEN.

Witnesses:

CHANDLER HALL,  
THOMAS E. BIRCH.