

B. R. BENJAMIN.
 GRAIN BINDER.
 APPLICATION FILED NOV. 10, 1910.

994,711.

Patented June 13, 1911.

2 SHEETS—SHEET 1.

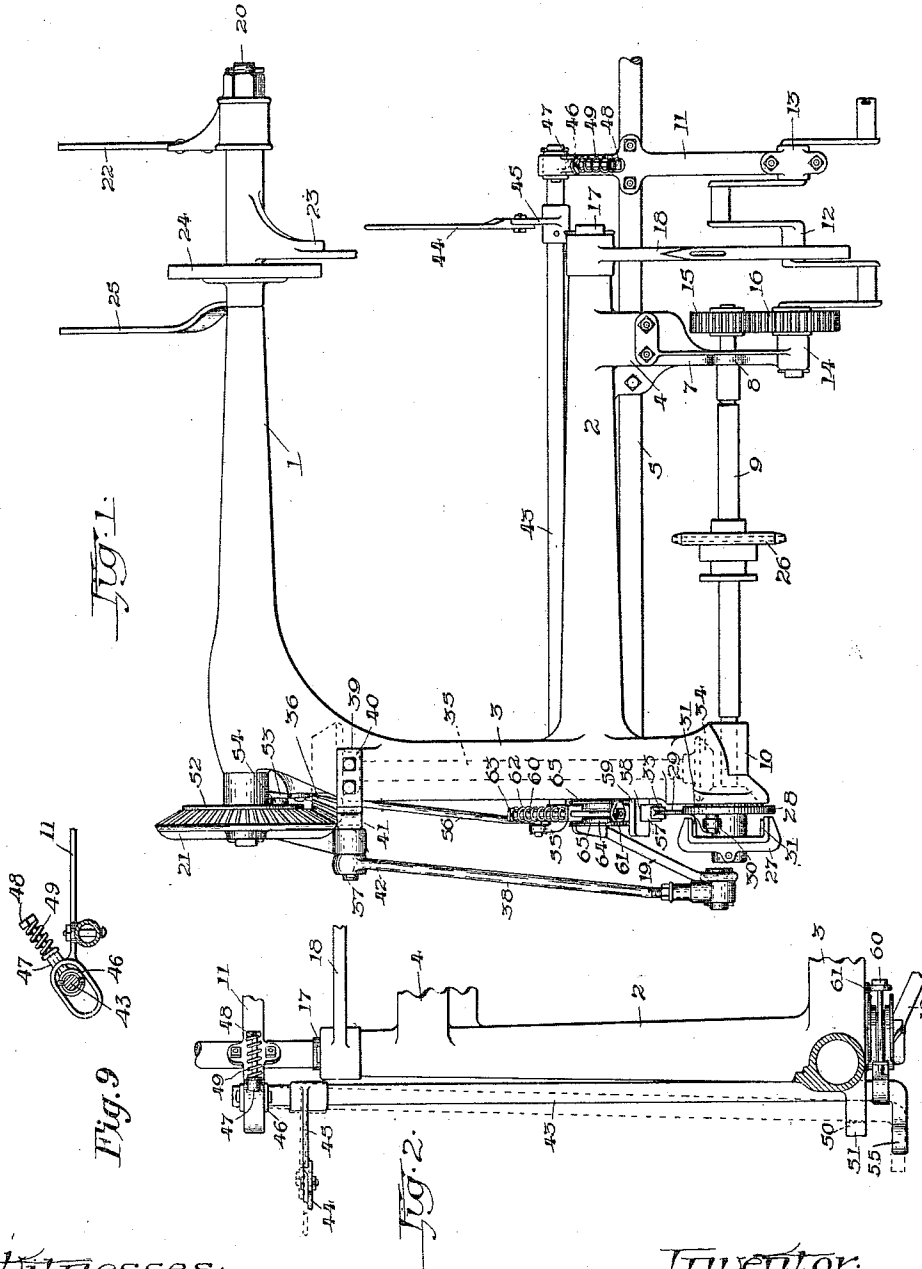

Witnesses:
F. W. Hoffmaster
W. H. Hoffmaster

Inventor:
Bert R. Benjamin
 By *Edw. R. Burgess*
 Attorney.

B. R. BENJAMIN.
GRAIN BINDER.

APPLICATION FILED NOV. 10, 1910.

994,711.

Patented June 13, 1911.

2 SHEETS—SHEET 2.

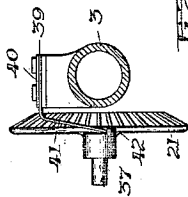
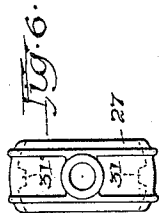
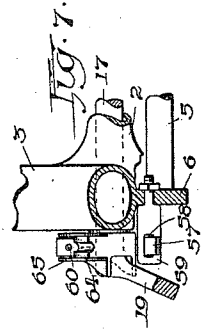
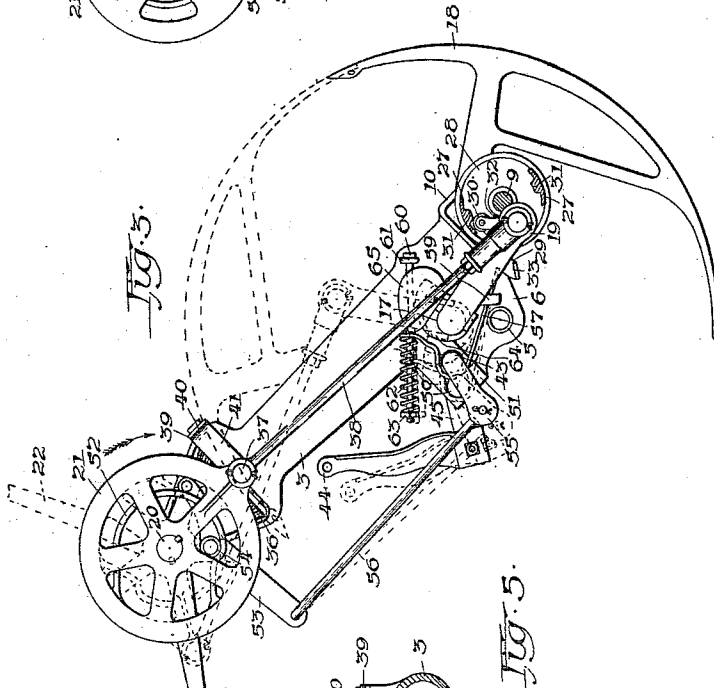
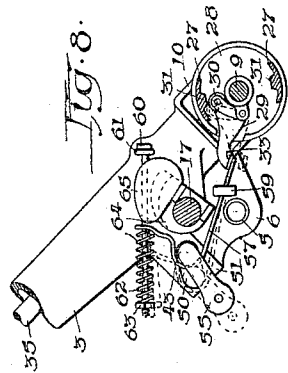
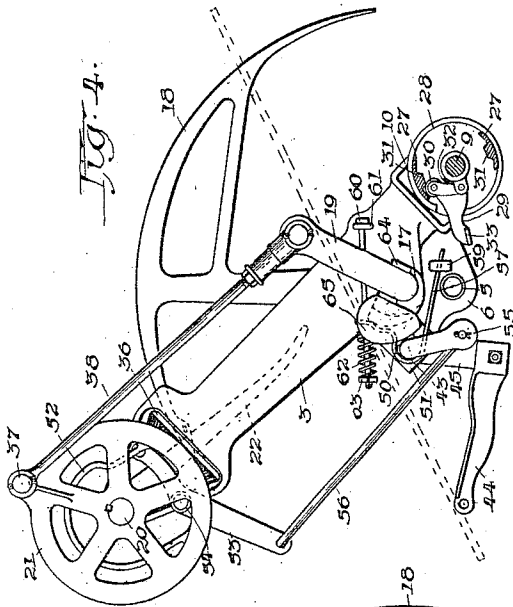

Witnesses
F. W. Hoffmeyer
W. H. Hoffmeyer

Inventor.
Bert R. Benjamin.
By E. W. Burgess
Attorney.

UNITED STATES PATENT OFFICE.

BERT R. BENJAMIN, OF OAK PARK, ILLINOIS, ASSIGNOR TO INTERNATIONAL HARVESTER COMPANY, A CORPORATION OF NEW JERSEY.

GRAIN-BINDER.

994,711.

Specification of Letters Patent. Patented June 13, 1911.

Application filed November 10, 1910. Serial No. 591,564.

To all whom it may concern:

Be it known that I, BERT R. BENJAMIN, a citizen of the United States, residing at Oak Park, in the county of Cook and State of Illinois, have invented certain new and useful Improvements in Grain-Binders, of which the following is a specification.

My invention relates to grain binders, and in particular to mechanism for automatically operating the clutch controlling member in a manner to release it from engagement with the clutch pawl forming part of the clutch mechanism, as commonly included in the usual construction of grain binder attachments for harvesters; the object of my invention being to provide a mechanism simple and strong in its construction and efficient in operation. I attain these objects by means of the mechanism illustrated in the accompanying drawings, in which—

Figure 1 represents a view of a grain binder at its receiving side and having my invention forming a part of the construction thereof; Fig. 2 represents a top plan view of the lower part of the binder frame, showing the manner of mounting the combined tripping and compressor shaft; Fig. 3 is an end elevation of Fig. 1 illustrating by full and dotted lines the different positions of the operative parts in their movement of binding the bundle; Fig. 4 is a similar view showing the position of the associated parts of the mechanism as the bundle is being discharged; Fig. 5 is a detail of the stop dog mechanism; Fig. 6 is a detail of the clutch mechanism; Fig. 7 is a detached detail, partly in section, designed to illustrate the manner of mounting the tripping slide; and Fig. 8 is a detached detail illustrating the operation of the tripping mechanism; Fig. 9 is a detached detail of the tripping and compressor mechanism at the opposite end of the frame structure from that shown in Fig. 8.

The same reference characters designate like parts throughout the several views.

The binder frame is one having a common form, including upper and lower longitudinally arranged tubular arms 1 and 2, respectively, that are connected by means of a hollow head piece 3, and 4 a transversely arranged arm integral with arm 2 and to which is secured a longitudinally arranged tubular frame member 5 that is supported at its forward end by means of an ear 6

integral with the lower end of the head piece and a bracket 7, having a bearing 8, in which is journaled one end of a shaft 9, having its opposite end journaled in a bearing 10 at the lower end of the head piece.

11 represents a bracket secured to the frame member 5, and 12 a multiple crank shaft forming part of the grain packing mechanism, journaled in bearings 13 and 14 forming part of brackets 11 and 7, respectively, the shaft being driven by means of a pinion 15 secured to shaft 9, and meshing with a pinion 16 secured to shaft 12.

17 represents the needle shaft journaled in arm 2, having a needle arm 18 secured to its inner end and a crank arm 19 upon its opposite end.

20 represents the knotter operating shaft journaled in arm 1, having a bevel gear wheel 21 secured to its outer end and a bundle discharging arm 22 to its opposite end.

23 represents the knotter frame in which the shaft is journaled, 24 the knotter cam wheel, and 25 a supplemental bundle discharging arm, both being secured to the knotter operating shaft.

The shaft 9 derives motion from an operative part of the harvester mechanism by means of sprocket wheel 26, that is slidably mounted thereon, and 27 represents a rotating clutch member secured to the outer end of said shaft and adapted to operatively engage with a pinion 28 loosely mounted thereon, the pinion having a pawl 29 pivotally mounted thereon and which is provided with a roller 30 that is adapted to engage with internal teeth 31 forming part of the clutch member 27, the pawl being yieldingly pressed toward the teeth, by means of a compression spring 32, operative between the hub of the pinion and the pawl, the latter being provided with an outwardly projecting arm 33 whereby its movement may be controlled. Pinion 28 meshes with pinion 34, secured to the lower end of a shaft 35 that is journaled in the head piece 3, and 36 represents a pinion secured to the opposite end of the shaft and meshing with the bevel gear wheel 21 secured to the knotter driving shaft.

37 represents a crank pin secured to the wheel 21 and operatively connected with the crank arm 19 of the needle shaft by means of the pitman 38.

39 represents a stop dog including an arm

40 secured to the head piece, and a depending resilient arm 41 adapted to mesh with an abutment 42 formed upon the adjacent face of wheel 21 in a manner to hold said wheel against a retrograde movement when it has reached a predetermined point in a forward direction.

43 represents a combined rocking, compressor and binder tripping shaft mounted upon the binder frame in a manner permitting it to move bodily away therefrom under pressure of the grain against the binder tripping and compressor arm 44, that is adjustably secured to an arm 45 secured to the shaft. The shaft is supported at its inner end by a yoke member 46, that is slidably connected with the outer end of bracket 11, the bracket being provided with an ear 47, through which passes a bolt 48 that is threaded into the yoke, the inner end of the bolt being surrounded by a compression spring 49, that is operative between the head of the bolt and the ear in a manner to resist a bodily movement of the shaft outward under pressure of the incoming grain. The opposite end of the shaft passes through a slotted opening 50 formed in an ear 51 integral with the binder frame and in which the shaft may move outward, as shown by dotted lines in Fig. 2.

52 represents the usual cam track upon the wheel 21, and 53 a compressor lever pivotally connected at its inner end with the binder frame and having a roller 54 journaled thereon intermediate its ends that is adapted to engage with the cam track in a manner to cause the opposite end of the lever, that is connected with a crank arm 55 formed upon the outer end of shaft 43 by means of a link 56, to rise and fall in a manner to cause the rock shaft to rotate toward or from the binder to compress the bundle or permit it to be discharged in a wellknown way. The movement of the shaft toward or from the binder frame controls the clutch tripping mechanism in the following manner:

57 represents a curved clutch tripping member bent in a manner to partially surround the rock shaft 43, having its inner end slidably received by opening 58 in stud 59, secured to the binder frame and adapted to contact with the clutch pawl arm 33 in a manner to disengage the pawl from the rotating clutch member 27, the opposite end of the clutch tripping member being curved inwardly and upwardly and provided with an opening therein, and 60 represents a bolt passing through an ear 61, forming part of the binder frame, and the opening in the tripping member, and having a compression spring 62 surrounding its upper end that is operative between an adjusting nut 63 and the tripping member in a manner to yieldingly press the shaft and

tripping member in a direction to cause the latter to engage with the pawl arm and to resist bodily movement of the shaft in an opposite direction.

64 represents a cam mounted upon the needle shaft, rotatable therewith and contacting with the tripping member, and operative to hold it disengaged from the pawl arm until the bundle has been discharged and the needle returned to its initial position, the cam being provided with a flange 65 that overlaps the tripping member during its operative movement.

In the operation of the machine the grain is compressed against the arm 44 by the packer mechanism in a well-known way until a predetermined amount is collected, when the arm and shaft will move bodily under the continued pressure against the action of springs 49 and 62 in a manner to withdraw the tripping member 57 from engagement with the pawl arm 33, and the pawl then engages with the rotating clutch member in a wellknown way and the binder mechanism begins its cycle of movement to bind and discharge the bundle, and at the end of the cycle the parts assume their initial position.

What I claim as my invention, and desire to secure by Letters Patent, is:

1. A grain binder including, in combination, a binder frame, a rocking binder tripping member supported upon said frame and adapted to move bodily in a lateral direction relative thereto, a clutch mechanism including a pivotally mounted pawl, a clutch controlling arm slidably mounted upon said frame and adapted to engage with said pawl, the movement of said arm being controlled by the bodily movement of said binder tripping member.

2. A grain binder including, in combination, a binder frame including longitudinally arranged arms, a rock shaft mounted upon one of said arms and adapted to move bodily in a lateral direction relative thereto, a binder tripping arm secured to said shaft and held normally within the path of the incoming grain, and clutch mechanism including a pivotally arranged pawl, a clutch controlling arm slidably mounted upon said frame and adapted to engage with said pawl, the movement of said arm being controlled by the bodily movement of said rock shaft.

3. A grain binder including, in combination, a binder frame including longitudinally arranged arms, a rock shaft mounted upon one of said arms and adapted to move bodily in a lateral direction relative thereto, a binder tripping arm secured to said shaft and held normally within the path of the incoming grain, and clutch mechanism including a pivotally arranged pawl, a clutch controlling arm slidably mounted upon said

frame and adapted to engage with said pawl, said clutch controlling arm engaging with said rock shaft in a manner to be moved in one direction as said shaft moves 5
bodily, and a spring operative to move it in an opposite direction.

4. A grain binder including, in combination, a binder frame including longitudinally arranged arms, a rock shaft mounted 10
upon one of said arms and adapted to move bodily in a lateral direction relative thereto, a binder tripping arm secured to said shaft and held normally within the path of the incoming grain, and clutch mechanism including a pivotally arranged pawl, a clutch 15
controlling arm slidably mounted upon said frame and having one end adapted to engage with said pawl, its body portion partially surrounding said rock shaft and its 20
opposite end having a spring connection with said frame whereby said controlling arm is yieldingly held in contact with said pawl.

5. A grain binder including, in combination, a binder frame including upper and 25
lower longitudinally arranged tubular arms, a head piece connecting said arms, a knotted actuating shaft journaled in said upper arm, a knotted actuating gear wheel 30
secured to the outer end of said shaft and having a cam track forming a part thereof, a compressor shaft supported upon said lower arm parallel therewith and adapted to move bodily laterally relative thereto, a 35
presser arm secured to the inner end of said shaft and normally held within the path of the incoming grain, a crank arm at the opposite end of said shaft, a lever having one end pivoted on said head piece, having 40
a roller mounted thereon intermediate its ends and engaging with said cam track, and a link connection between the opposite end of said lever and said crank arm forming part of said compressor shaft.

45 6. A grain binder including, in combination, a binder frame including upper and lower longitudinally arranged tubular arms, a frame member supported by said lower

arm, a bracket secured to said frame member, a yoke yieldingly connected with said 50
bracket, a compressor shaft having its inner end journaled in said yoke and its opposite end received by a slotted opening in an ear forming part of said lower arm, said shaft being adapted to move bodily laterally 55
relative to said lower arm, a presser arm secured to the inner end of said shaft and normally held within the path of the incoming grain, a crank arm at the opposite end of said shaft, a lever having one end pivoted 60
upon said binder frame and having a roller mounted thereon intermediate its ends, a knotted actuating shaft journaled in said upper tubular arm, a knotted actuating gear wheel secured to the outer end of said shaft 65
and having a cam track forming a part thereof, said roller engaging with said cam track, and the opposite end of said lever having a link connection with said crank arm.

7. A grain binder including, in combination, a binder frame including upper and 70
lower longitudinally arranged tubular arms, a head piece connecting said arms, a knotted actuating shaft journaled in said upper arm, and a needle shaft journaled in said lower 75
arm, and means for rocking it in its bearings, a combined tripping, compressor and rock shaft parallel with and supported by said lower arm and adapted to move bodily in a lateral direction relative thereto, and 80
clutch mechanism including a pivotally arranged pawl, a clutch controlling arm slidably mounted upon said head piece and adapted to engage with said pawl, the movement of said arm being controlled by the 85
bodily movement of said combined tripping, compressor and rock shaft, and an arm secured to said needle shaft and operative to hold said clutch controlling arm disengaged from said pawl when said shaft is rocked in 90
one direction.

BERT R. BENJAMIN.

Witnesses:

RAY D. LEE,
A. M. CHRISTIAN.