

(19) World Intellectual Property
Organization
International Bureau



(43) International Publication Date
1 December 2005 (01.12.2005)

PCT

(10) International Publication Number
WO 2005/113244 A1

- (51) International Patent Classification⁷: **B41F 35/00**, C11D 3/20, B41N 3/06
- (21) International Application Number: PCT/US2005/014126
- (22) International Filing Date: 22 April 2005 (22.04.2005)
- (25) Filing Language: English
- (26) Publication Language: English
- (30) Priority Data: 10/839,739 5 May 2004 (05.05.2004) US
- (71) Applicant (for all designated States except US): **BBA NONWOVENS SIMPSONVILLE, INC.** [US/US]; 840 S.E. Main Street, Simpsonville, SC 29681 (US).
- (72) Inventors; and
- (75) Inventors/Applicants (for US only): **HOWEY, Jon, A.** [US/US]; 106 Steeple Chase Court, Simpsonville, SC 29681 (US). **DELGADO, Emil** [US/US]; 107 Sorrento Drive, Moore, SC 29369 (US).
- (74) Agents: **LINKER, Raymond, O., Jr.** et al.; Alston & Bird LLP, Bank of America Plaza, 101 South Tryon Street, Suite 4000, Charlotte, NC 28280-4000 (US).
- (81) Designated States (unless otherwise indicated, for every kind of national protection available): AE, AG, AL, AM, AT, AU, AZ, BA, BB, BG, BR, BW, BY, BZ, CA, CH, CN, CO, CR, CU, CZ, DE, DK, DM, DZ, EC, EE, EG, ES, FI, GB, GD, GE, GH, GM, HR, HU, ID, IL, IN, IS, JP, KE, KG, KM, KP, KR, KZ, LC, LK, LR, LS, LT, LU, LV, MA, MD, MG, MK, MN, MW, MX, MZ, NA, NI, NO, NZ, OM, PG, PH, PL, PT, RO, RU, SC, SD, SE, SG, SK, SL, SM, SY, TJ, TM, TN, TR, TT, TZ, UA, UG, US, UZ, VC, VN, YU, ZA, ZM, ZW.
- (84) Designated States (unless otherwise indicated, for every kind of regional protection available): ARIPO (BW, GH, GM, KE, LS, MW, MZ, NA, SD, SL, SZ, TZ, UG, ZM, ZW), Eurasian (AM, AZ, BY, KG, KZ, MD, RU, TJ, TM), European (AT, BE, BG, CH, CY, CZ, DE, DK, EE, ES, FI, FR, GB, GR, HU, IE, IS, IT, LT, LU, MC, NL, PL, PT, RO, SE, SI, SK, TR), OAPI (BF, BJ, CF, CG, CI, CM, GA, GN, GQ, GW, ML, MR, NE, SN, TD, TG).

[Continued on next page]

(54) Title: COMPOSITION AND MATERIAL FOR CLEANING PRINTING MACHINES

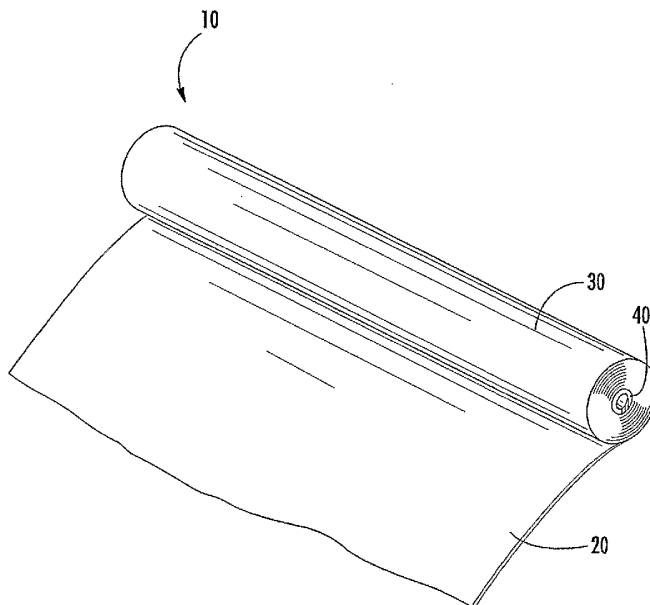

(57) Abstract: A cleaning material (20) and cleaning composition for cleaning printing machines utilizes branched chain monobasic and/or dibasic esters that contain 2-ethyl hexanoate. The cleaning material (20) is comprised of a fabric that has been impregnated with the cleaning composition. The cleaning composition can also include additional low volatility solvents and surfactants. A particularly useful cleaning composition is comprised of isobutyl stearate in combination with branched chain monobasic and/or dibasic esters that contain 2-ethyl hexanoate. The cleaning material (20) can be wound onto a roll (10) that can be adaptable to fit commercially available printing machine cleaning devices.

WO 2005/113244 A1



Published:

— *with international search report*

For two-letter codes and other abbreviations, refer to the "Guidance Notes on Codes and Abbreviations" appearing at the beginning of each regular issue of the PCT Gazette.

COMPOSITION AND MATERIAL FOR CLEANING PRINTING MACHINES

BACKGROUND OF THE INVENTION

The invention relates generally to a cleaning material that can be used to clean a printing machine, and more particularly to a cleaning material in the form of a fabric impregnated with a cleaning composition.

5 One of the more common printing techniques is offset lithography printing. In offset printing, an ink roll transfers ink to a plate cylinder. The plate cylinder typically contains lithographic plates that are wrapped around the circumference of the cylinder. After the lithographic plates contact the ink roller, the plate cylinder then transfers the inked impression onto a blanket cylinder. The blanket cylinder is
10 typically made of a soft material such as rubber. The blanket cylinder transfers the inked impression to a printable surface such as a continuous web of paper. In a blanket-to-blanket press, the paper web is fed between two blanket cylinders so that both sides of the paper are printed at once.

 During the printing process, ink, dirt, and other residues may accumulate
15 on the blanket cylinders. The accumulation of such residues can cause various problems, such as poor print image quality and damage to the blanket. Additionally, the blanket cylinder should be cleaned when the plates on the plate cylinder are changed.

 Traditionally, when a printing press needed cleaning, the press would be
20 taken off-line and the equipment would be hand cleaned with solvents. Hand cleaning the printing press has several disadvantages. Hand cleaning can be labor intensive and possibly very time consuming, which could result in the printing press having to be off-line for a significant amount of time.

 Several automated systems have been developed to improve printing press
25 cleaning, reduce the amount of solvent consumed, and to lessen the amount of printing press downtime. Typically, these systems involve the use of a cleaning

fabric that has been impregnated with a cleaning composition. The cleaning fabric is usually applied to the rollers and cylinders under tension or pressure so that the cleaning fabric has adequate contact with the surfaces that are being cleaned. The cleaning fabric can be unrolled from a roll and directed into contact with the
5 blanket surface. The used portions of the fabric are then typically rolled onto a separate uptake roll for later disposal. Cleaning fabrics of this type are described, for example, in U.S. Patent Nos. 5,368,157 and 6,263,795.

The cleaning compositions are typically comprised of low volatility organic solvents that are designed to remove inks and other residues from the surface of the
10 blanket. Typically, solvents having higher volatilities are more effective in removing ink from the blanket. As a consequence, performance can be sacrificed because of the desire to use a solvent that will not quickly evaporate under ambient temperature and pressure. In some cases, the cleaning composition can also deteriorate the surface of the blanket.

15 Although current cleaning compositions have enjoyed widespread use in the cleaning of printing presses, there exists a need for an improved cleaning fabric having a cleaning composition that has excellent cleaning performance, low volatility, and does not adversely affect the blanket.

BRIEF SUMMARY OF THE INVENTION

20 The present invention provides a cleaning composition that is particularly useful for cleaning printing press cylinders. Typically, a fabric is impregnated with the cleaning composition to produce a cleaning material that is adeptly suited for cleaning printing press blankets. The cleaning composition is comprised of branched chain monobasic and dibasic esters that contain 2-ethyl hexanoate.
25 Monobasic and dibasic esters containing 2-ethyl hexanoate are adeptly suited for cleaning printing presses because they have low-volatility, excellent cleaning properties for removing ink and other residues from the cylinders, and do not adversely affect the surface of the polymeric blanket.

The cleaning composition can also include additional low volatility
30 solvents and surfactants. A particularly useful cleaning composition is comprised

of isobutyl stearate in combination with branched chain monobasic and dibasic esters that contain 2-ethyl hexanoate.

The cleaning composition can be used with a cleaning cloth that is typically comprised of a fabric material. The fabric is typically impregnated with the
5 cleaning composition, or is soaked in the cleaning composition before application to the blanket. The impregnated cleaning material can also be tightly wound onto a roll that can be used with commercially available cleaning devices.

The cleaning composition can be used with a variety of fabrics. Typically, the fabric is a nonwoven that has good strength and abrasion resistance. A
10 spunbond nonwoven fabric is a particularly useful cleaning cloth. Typically, the spunbonded fabric comprises a web of substantially continuous filaments thermally point bonded together to provide a fabric with excellent strength and abrasion resistance while being able to carry and release adequate amounts of a cleaning solvent. The spunbonded nonwoven fabric has a relatively low loft or volume,
15 making it adeptly suited for being tightly wound on a roll without the need for post calendering.

Thus, the invention provides, among other things, an improved printing machine cleaning composition having excellent cleaning properties and low volatility, and that can be used to impregnate a fabric material to provide a
20 cleaning material that is exceptionally effective in cleaning a printing blanket and that does not deteriorate the surface of the printing blanket.

BRIEF DESCRIPTION OF THE SEVERAL VIEWS OF THE DRAWING(S)

Having thus described the invention in general terms, reference will now be made to the accompanying drawing, which is not necessarily drawn to scale, and
25 wherein:

FIG. 1 illustrates a cleaning material that is wound onto a roll around a central core.

DETAILED DESCRIPTION OF THE INVENTION

The present invention now will be described more fully hereinafter with
30 reference to the accompanying drawing, in which some, but not all embodiments of the invention are shown. Indeed, the invention may be embodied in many

different forms and should not be construed as limited to the embodiments set forth herein; rather, these embodiments are provided so that this disclosure will satisfy applicable legal requirements.

The cleaning composition is comprised of a low volatility solvent that does not readily evaporate at ambient temperature and pressure. Esters are particularly useful as organic solvents because they are typically biodegradable and many exhibit low vapor pressure. Particularly suitable are branched chain monobasic and dibasic esters that contain 2-ethyl hexanoate because they provide exceptional cleaning power. These include, without limitation, di(propylene glycol) di-2-ethylhexanoate, di (ethylene glycol) di-2-ethylhexanoate, neopentylglycol di-2-ethylhexanoate, 1,6-hexanediol di-2-ethylhexanoate (1:1), di-2-ethylhexyl adipate, octyl / decyl 2-ethylhexanoate. An exemplary cleaning composition includes octyl / decyl 2-ethylhexanoate. The amount of branched chain monobasic and/or dibasic esters that contain 2-ethyl hexanoate in the composition can be up to 100 %.

Typically, the amount of 2-ethyl hexanoate in the cleaning composition is from about 5 to 100 %, and somewhat more desirably is an amount from about 25 to 100 %.

An additional novel feature of these esters used in the cleaning composition of the present invention is that though exhibiting strong ink solvency, they have minimal interaction with the polymeric blanket substrates used for lithographic printing. This minimal interaction with polymeric substrates allows for efficient cleaning of the blanket without surface deterioration or other adverse effects after repeated wiping cycles.

Isobutyl stearate is an excellent additive when in combination with branched chain monobasic and/or dibasic esters that contain 2-ethyl hexanoate. Isobutyl stearate is a common, low cost fluid with exceptional lubricity. Lubricity is helpful in reducing abrasion between the nonwoven fabric and the blanket. Isobutyl stearate cannot be used alone because of its low cleaning power. The amount of isobutyl stearate in the composition can be from about 0 to 50 %.

Other low volatility solvents can be used in cleaning composition including, without limitation, esters, methyl esters, glycols, aromatic hydrocarbons,

branched or unbranched aliphatic hydrocarbons, and combinations and blends thereof.

The cleaning composition can also contain surfactants. The addition of a surfactant will help emulsify water that may be present on the presses. Water may
5 be sprayed on the blanket to assist in removing any dirt or paper dust that may have accumulated. The amount of surfactant present in the solvent composition is typically from about 0 to 40 % by weight. A somewhat more typical range is from about 5 to 15 % by weight. The surfactant can also help remove ink residue by
10 suspending it in water that can be removed from the surface. Additionally, the surfactants can act as an emulsifier between the aqueous, acidic or alkaline phase and the hydrocarbon phase. It is believed that the emulsion drops help loosen the printing ink and suspend it in the aqueous phase and support the surfactant molecules in stabilizing the emulsion while also stabilizing any droplets containing
15 printing ink. Typically, the surfactant can be non-ionic, anionic, or cationic. An exemplary surfactant suitable for use in the present invention is Ethox 2680, which is an alkyl, polyoxyalkylene glycol ether.

One exemplary cleaning composition formulation contains 75 percent by weight octyl / decyl 2-ethylhexanoate, 20 percent by weight isobutyl stearate, and
5 percent by weight alkyl-polyoxyalkylene glycol ether surfactant.

The cleaning composition can be used in many different applications that
20 are used in printing press cleaning. For instance, the cleaning composition can be used to impregnate a roll of cleaning cloth or fabric that can be used in automated cleaning systems. Alternatively, the cleaning composition can be applied to the fabric on-site by soaking the fabric in the cleaning composition before application
25 to the blanket. The cleaning composition can also be used in other applications, and as such, its use is not limited to printing press cleaning.

With reference to FIG. 1, reference number **10** broadly designates a roll of cleaning material that is in accordance with the invention. As depicted in FIG. 1, the cleaning material **20** is wound around a central core **40** to form a roll of
30 cleaning material. The cleaning material **20** has been impregnated with the cleaning composition.

The size, shape, and configuration of the roll **10** and core **40** can be adjusted so that the roll of cleaning material **10** can be used interchangeably with commercially available printing press cleaning devices. The cleaning material can be integrated into an automatic blanket cleaning system so that at a desired time
5 the cleaning material is applied to the blanket with even pressure. Cleaning is accomplished by friction between the cleaning material and the blanket, and the dissolution of inks on the blanket. The used portion of the cleaning material can be reeled onto a take-up shaft or similar device.

The amount of cleaning composition present in the cleaning material roll is
10 typically from about 20 to 200 grams per square meter (gsm). Less cleaning composition, typically from about 20 to 100 gsm, is required on sheet fed presses that run at speeds up to 20,000 impression cylinder revolutions per hour. More cleaning composition, typically from about 80 to 200 gsm, is required on web fed presses that run at speeds exceeding 20,000 impression cylinder revolutions per
15 hour.

Typically, the cleaning material is packaged in a wrapper or container that is impermeable to fluids and substantially impermeable to vapors. The wrapper and container can be made from a variety of different materials such as film made from a thermoplastic resin. The cleaning material is typically stored in the sealed
20 wrapper or container until it is needed. At the appropriate time, the cleaning cloth can be removed from the wrapper and used to clean a printing press cylinder or blanket.

Suitable cleaning fabrics can be made from a wide variety of different materials, and should have good strength and abrasion resistance. For example, the
25 fabric can be made of paper, cloth, film, a mixture of wood pulp and polymeric materials such as polyester. The fabric can be a cloth that is prepared from woven or nonwoven cloth fabric that is comprised of synthetic or natural fibers or mixtures thereof. Exemplary synthetic fibers include, without limitation, nylon fibers, rayon fibers, polyester fibers, acrylic fibers, and the like. Exemplary natural
30 fibers include, without limitation, cotton, wood pulp, hemp, wool, and the like.

A particularly useful cleaning fabric is comprised of a nonwoven fabric. A wide variety of different nonwovens can be used in the invention including, but not

limited to, melt-blown nonwovens, spunbonded nonwovens, spun-laced nonwovens, air-laid nonwovens, and wet-laid nonwovens. The fibers/filaments are typically bonded together using chemical bonding, thermal bonding, or mechanical bonding. Thermal bonding processes include hot calendaring, belt calendaring, oven bonding, ultrasonic bonding, radiant heat bonding, and the like.

The spunbond nonwovens used in the present invention are made from continuous polymeric filaments that are thermally bonded together. Generally, spunbond nonwoven fabrics are prepared by extruding a thermoplastic polymer through a large number of fine spinneret orifices to form a multiplicity of continuous filaments, and the filaments of molten polymer are solidified and then drawn or attenuated, typically by high velocity air, and then randomly deposited on a collection surface. The filaments are then bonded to give the web coherency and strength. Area bonding and point bonding are two common techniques for thermally bonding the web. Area bonding typically involves passing the web through a heated calendar composed of two smooth steel rollers or passing heated steam, air or other gas through the web to cause the filaments to become softened and fuse to one another. Point bonding consists of using a heated calender nip to produce numerous discrete bond sites. The point bonding calender nip is comprised of two nip rolls, wherein at least one of the rolls has a surface with a patterned of protrusions. Typically, one of the heated rolls is a patterned roll and the cooperating roll has a smooth surface. As the web moves through the calender roll, the individual filaments are thermally bonded together at discrete locations or bond sites where the filaments contact the protrusions of the patterned roll. Preferably, the calender rolls are engraved with a pattern that produces point bonds over about 10 to 40 percent of the area of web surface, and more preferably about 20 to 30 percent.

For the present invention, thermal point bonding either with heat and pressure or by ultrasonics is the preferred bonding process because it coheres the filaments in small, discrete, and closely spaced areas of the web to produce a fabric that is quite strong and abrasion resistant. Point bonding imparts considerable strength to the fabric while retaining the integrity of the fibrous structure on both surfaces. In contrast, other bonding methods that are used to achieve high strength

fabrics, such as area bonding, can result in glazing the surface of the fibers. As a result, the fibers can lose much of their fibrous nature and become "film-like." This is usually an undesirable result because a cleaning cloth that is film-like will not typically clean as well as a fibrous cleaning cloth. On the other hand, if the thermally bonded nonwoven is too lightly bonded, the fibers near the surface might maintain their fibrous nature, and as a result, the abrasion resistance of the fabric could be compromised. The fibrous surface of the highly abrasion resistant point bonded fabric contributes to the ability of the fabric to remove ink and debris from the surfaces of the printing press undergoing cleaning. Additionally, patterned point bonding creates a fabric structure having a large number of "pockets" of relatively uncompacted filaments located between the more compacted and densified point bond sites. This structure enhances the ability of the fabric to hold and retain cleaning solvent during storage of the cleaning material prior to use, and to release the solvent onto the surfaces of the printing press during the cleaning operation. As a result, cleaning materials that are prepared in accordance with the invention are adeptly suited for removing ink and other residues from printing machinery.

Spunbonded nonwoven fabrics can be prepared from a variety of different thermoplastic polymers that are capable of being melt spun to form filaments. Examples of polymers that can be used to form the spunbonded nonwoven fabric include, without limitation, polyester, polyamide, polyolefins such as polypropylene, polyethylene, and olefin copolymers, or other thermoplastic polymers, copolymers and blends. These polymers may also be used in any combination or shape to form bicomponent or tricomponent filaments.

A particularly useful spunbond nonwoven fabric is comprised of polyester filaments, and more particularly is formed from polyester homopolymer filaments. A variety of additives can be used with the homopolymer including, but not limited to, optical brighteners, delusterants, opacifiers, colorants, antistats, and other common melt additives. A fibrous binder may also be included within the spunbond nonwoven fabric during the manufacturing process as continuous binder filaments in an amount effective to induce an adequate level of bonding. The binder is typically present in an amount ranging from about 2 to 20 weight percent,

such as an amount of about 10 weight percent. The binder filaments are generally formed from a polymer composition exhibiting a melting or softening temperature at least about 10° C lower than the homopolymer continuous filaments. Exemplary binder filaments may be formed from one or more lower melting polymers or
5 copolymers, such as polyester copolymers. In one advantageous embodiment of the invention, the spunbond layer is produced by extruding polyester homopolymer matrix filaments (polyethylene terephthalate) interspersed with binder filaments formed from a lower melting polyester copolymer, such as polyethylene isophthalate. Typically, the homopolymer filaments constitute the matrix fiber and
10 the copolymer filaments have a lower melting point and constitute a binder filament. Generally, as the web passes through the calender rolls, discrete point bonds are formed where the patterned roller contacts the individual filaments. The portions of the binder filaments that contact the heated protrusions on the calender roll are melted or rendered tacky while in contact with the heat calender roll, and
15 as a result, the binder and matrix fibers are bonded together to form a strong coherent fabric.

Suitable nonwoven fabrics should have a machine direction tensile strength typically of about 11,000 grams per inch (2.54 centimeter) and preferably at least 5,000 grams per inch (2.54 centimeter). The nonwoven fabrics should also
20 typically have a basis weight of from 40 to 125 gsm, and more desirably from about 60 to 90 gsm. The fabric typically has a machine direction elongation from about 19 to 49 percent, and somewhat more typically about 34 percent. The fabric typically has a Frasier porosity of at least 100 cubic feet of air per minute per square foot of fabric at a pressure differential of 0.5 inches of water.

25 As should be evident from the above disclosure, the cleaning compositions of the invention can be used in a wide variety of cleaning applications, and are not limited to printing press cleaning.

Many modifications and other embodiments of the invention set forth herein will come to mind to one skilled in the art to which the invention pertains
30 having the benefit of the teachings presented in the foregoing descriptions and the associated drawing. Therefore, it is to be understood that the invention is not to be limited to the specific embodiments disclosed and that modifications and other

embodiments are intended to be included within the scope of the appended claims. Although specific terms are employed herein, they are used in a generic and descriptive sense only and not for purposes of limitation.

THAT WHICH IS CLAIMED:

1. A cleaning material for cleaning printing machines comprising a fabric wound into the form of a roll, and cleaning composition impregnating the roll of fabric, said cleaning composition comprising a branched chain monobasic and/or dibasic esters containing 2-ethyl hexanoate.
5
2. The cleaning material of claim 1, additionally including a sealed wrapper surrounding the roll of impregnated fabric.
3. The cleaning material of claim 1 or 2, additionally including a core around which the fabric is wound into the form of a roll.
- 10 4. The cleaning material of any preceding claim, wherein the fabric is comprised of nylon fibers, rayon fibers, polyester fibers, acrylic fibers, cotton fibers, wood pulp, hemp fibers, or wool, or blends thereof.
5. The cleaning material of any preceding claim, wherein the fabric is a spunbond nonwoven fabric that is comprised of polyester filaments.
- 15 6. The cleaning material of any preceding claim, wherein the cleaning composition is present in the fabric at from about 20 to 200 gsm.
7. The cleaning material of any preceding claim, wherein the cleaning composition includes branched chain monobasic and/or dibasic esters containing 2-ethyl hexanoate and a surfactant.
- 20 8. The cleaning material of any one of claims 1 to 6, wherein the cleaning composition includes branched chain monobasic and/or dibasic esters containing 2-ethyl hexanoate and isobutyl stearate.
9. The cleaning material of any one of claims 1 to 6, wherein the cleaning composition includes branched chain monobasic and/or dibasic esters
25 containing 2-ethyl hexanoate, isobutyl stearate and a surfactant.

10. The cleaning material according to claim 9, wherein the amount of branched chain monobasic and/or dibasic esters containing 2-ethyl hexanoate is up to 100 weight percent; the amount of isobutyl stearate is from about 0 to 50 weight percent, and the amount of surfactant is from about 0 to 40 weight percent.
- 5 11. The cleaning material of claim 10, wherein the fabric has a basis weight of from 40 to 125 gsm, and cleaning composition is present in the fabric at from about 20 to 200 gsm.
12. A cleaning composition for cleaning printing machines comprising branched chain monobasic and/or dibasic esters containing 2-ethyl hexanoate.
- 10 13. The cleaning composition according to claim 12, wherein the cleaning composition includes branched chain monobasic and/or dibasic esters containing 2-ethyl hexanoate and isobutyl stearate.
14. The cleaning composition of claim 12, wherein the cleaning composition includes branched chain monobasic and/or dibasic esters containing 2-ethyl hexanoate, isobutyl stearate and a surfactant.
- 15 15. The cleaning composition according to claim 14, wherein the surfactant is alkyl-polyoxyalkylene glycol ether.
16. The cleaning composition according to any one of claims 12 to 15 wherein the branched chain monobasic or dibasic esters containing 2-ethyl hexanoate is at least one member selected from the group consisting of di(propylene glycol) di-2-ethylhexanoate, di (ethylene glycol) di-2-ethylhexanoate, neopentylglycol di-2-ethylhexanoate, 1,6-hexanediol di-2-ethylhexanoate (1:1), di-2-ethylhexyl adipate, and octyl / decyl 2-ethylhexanoate.
- 20 17. The cleaning composition according to claim 14 or 15, wherein the amount of branched chain monobasic and/or dibasic esters containing 2-ethyl hexanoate is up to 100 weight percent; the amount of isobutyl stearate is from about 0 to 50 weight percent, and the amount of surfactant is from about 0 to 40 weight percent.
- 25

18. The use of branched chain monobasic and/or dibasic esters containing 2-ethyl hexanoate for cleaning printing machines.

19. The use of branched chain monobasic and/or dibasic esters containing 2-ethyl hexanoate as claimed in claim 18 as an impregnant in a cleaning
5 fabric for cleaning printing machines.

1/1

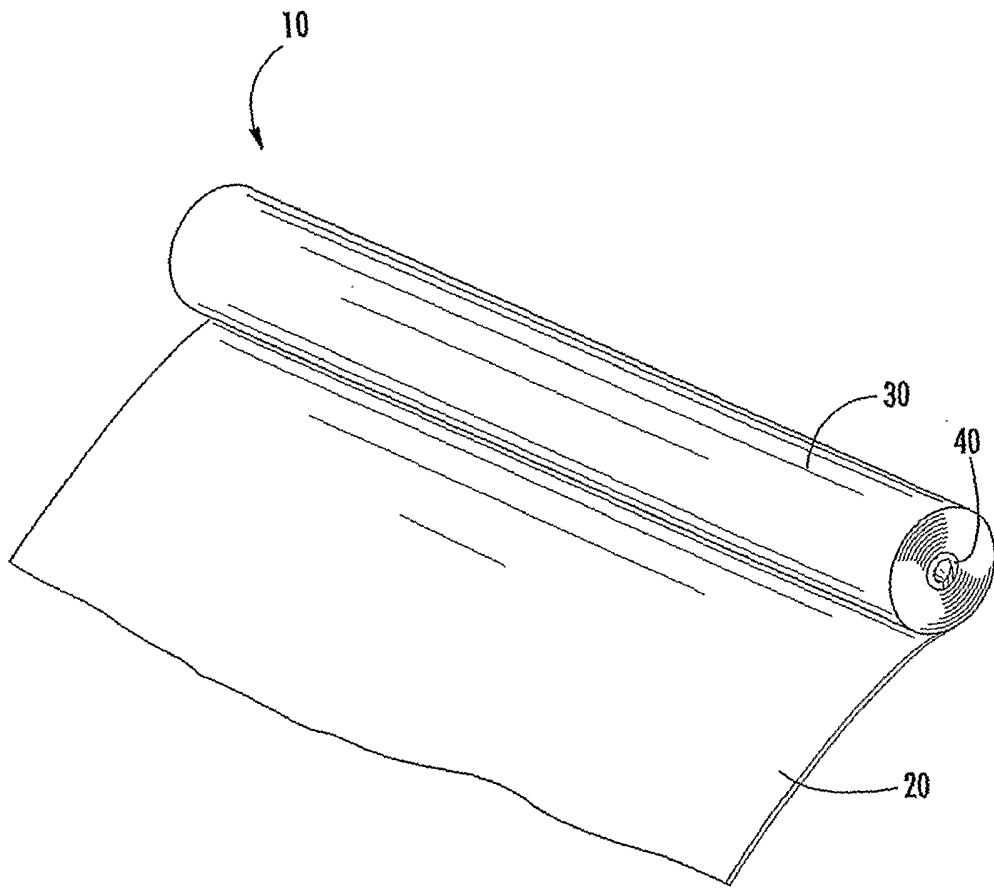

FIG. 1

INTERNATIONAL SEARCH REPORT

International Application No
PCT/US2005/014126

A. CLASSIFICATION OF SUBJECT MATTER
 IPC 7 B41F35/00 C11D3/20 B41N3/06

According to International Patent Classification (IPC) or to both national classification and IPC

B. FIELDS SEARCHED
 Minimum documentation searched (classification system followed by classification symbols)
 IPC 7 B41F G03G C11D B41N

Documentation searched other than minimum documentation to the extent that such documents are included in the fields searched

Electronic data base consulted during the international search (name of data base and, where practical, search terms used)
 EPO-Internal, WPI Data

C. DOCUMENTS CONSIDERED TO BE RELEVANT

Category °	Citation of document, with indication, where appropriate, of the relevant passages	Relevant to claim No.
Y	EP 0 747 218 A (BALDWIN GRAPHIC SYSTEMS, INC) 11 December 1996 (1996-12-11) column 7, line 22 - column 9, line 8 figure 1	1-4,7, 11,19
X	DE 40 34 765 A1 (BERND SCHWEGMANN GMBH & CO KG, 5300 BONN, DE) 7 May 1992 (1992-05-07) page 2, lines 33-36,56-64	12,18
Y	----- -/--	1-4,7, 11,19

Further documents are listed in the continuation of box C. Patent family members are listed in annex.

° Special categories of cited documents :

"A" document defining the general state of the art which is not considered to be of particular relevance "E" earlier document but published on or after the international filing date "L" document which may throw doubts on priority claim(s) or which is cited to establish the publication date of another citation or other special reason (as specified) "O" document referring to an oral disclosure, use, exhibition or other means "P" document published prior to the international filing date but later than the priority date claimed	"T" later document published after the international filing date or priority date and not in conflict with the application but cited to understand the principle or theory underlying the invention "X" document of particular relevance; the claimed invention cannot be considered novel or cannot be considered to involve an inventive step when the document is taken alone "Y" document of particular relevance; the claimed invention cannot be considered to involve an inventive step when the document is combined with one or more other such documents, such combination being obvious to a person skilled in the art. "&" document member of the same patent family
---	---

Date of the actual completion of the international search 20 July 2005	Date of mailing of the international search report 27/07/2005
--	---

Name and mailing address of the ISA European Patent Office, P.B. 5818 Patentlaan 2 NL - 2280 HV Rijswijk Tel. (+31-70) 340-2040, Tx. 31 651 epo nl, Fax: (+31-70) 340-3016	Authorized officer Curt, D
--	--

INTERNATIONAL SEARCH REPORT

International Application No
PCT/US2005/014126

C.(Continuation) DOCUMENTS CONSIDERED TO BE RELEVANT		
Category °	Citation of document, with indication, where appropriate, of the relevant passages	Relevant to claim No.
X	US 2001/008877 A1 (HARTMANN THOMAS ET AL) 19 July 2001 (2001-07-19) the whole document page 1, paragraph 2 page 2, paragraphs 28,29 page 3, paragraph 45 page 4, paragraph 51-53 page 6, paragraph 73	12,18,19
A		1,7
X	----- EP 0 498 545 A (DU PONT LIMITED) 12 August 1992 (1992-08-12) page 2, line 1 - page 5, line 45 -----	12-14,18

INTERNATIONAL SEARCH REPORT

 International Application No
 PCT/US2005/014126

Patent document cited in search report		Publication date	Patent family member(s)	Publication date
EP 0747218	A	11-12-1996	US 6035483 A	14-03-2000
			CN 1347976 A	08-05-2002
			CN 1137976 A ,C	18-12-1996
			DE 69609249 D1	17-08-2000
			DE 69609249 T2	22-02-2001
			EP 0747218 A2	11-12-1996
			HK 1014519 A1	08-12-2000
			JP 8336960 A	24-12-1996

DE 4034765	A1	07-05-1992	NONE	

US 2001008877	A1	19-07-2001	DE 19963124 A1	12-07-2001
			CA 2329535 A1	24-06-2001
			EP 1111036 A2	27-06-2001
			JP 3527198 B2	17-05-2004
			JP 2001234199 A	28-08-2001

EP 0498545	A	12-08-1992	AT 128672 T	15-10-1995
			AU 1050692 A	06-08-1992
			BR 9200264 A	06-10-1992
			CA 2060266 A1	30-07-1992
			DE 69205184 D1	09-11-1995
			DE 69205184 T2	07-03-1996
			EP 0498545 A1	12-08-1992
			ES 2080438 T3	01-02-1996
			FI 920358 A	30-07-1992
			IE 920273 A1	29-07-1992
			JP 5246018 A	24-09-1993
			NO 920373 A	30-07-1992
			US 5194173 A	16-03-1993
			ZA 9200518 A	28-10-1992
