



(51) International Patent Classification:

A24F 40/40 (2020.01) A24F 40/20 (2020.01)
A24F 40/57 (2020.01) A24F 47/00 (2020.01)

(21) International Application Number:

PCT/SG2022/050164

(22) International Filing Date:

25 March 2022 (25.03.2022)

(25) Filing Language:

English

(26) Publication Language:

English

(30) Priority Data:

21165276.3 26 March 2021 (26.03.2021) EP

(71) Applicant: STARKER INTERNATIONAL PTE. LTD.

[SG/SG]; 401 Commonwealth Drive, #07-01/02, Haw Par Technocentre, Singapore 149598 (SG).

(72) Inventor: SEANG, Kiew Yong; c/o 401 Commonwealth Drive, #07-01/02, Haw Par Technocentre, Singapore 149598 (SG).

(74) Agent: VIERING, JENTSCHURA & PARTNER LLP; P.O. Box 1088, Rochor Post Office, Rochor Road, Singapore 911833 (SG).

(81) Designated States (unless otherwise indicated, for every kind of national protection available): AE, AG, AL, AM, AO, AT, AU, AZ, BA, BB, BG, BH, BN, BR, BW, BY, BZ, CA, CH, CL, CN, CO, CR, CU, CZ, DE, DJ, DK, DM, DO, DZ, EC, EE, EG, ES, FI, GB, GD, GE, GH, GM, GT, HN, HR, HU, ID, IL, IN, IR, IS, IT, JM, JO, JP, KE, KG, KH, KN, KP, KR, KW, KZ, LA, LC, LK, LR, LS, LU, LY, MA, MD, ME, MG, MK, MN, MW, MX, MY, MZ, NA, NG, NI, NO, NZ, OM, PA, PE, PG, PH, PL, PT, QA, RO, RS, RU, RW, SA, SC, SD, SE, SG, SK, SL, ST, SV, SY, TH, TJ, TM,

(54) Title: HEATING DEVICE, HEATING ELEMENT AND AEROSOL GENERATING PRODUCT

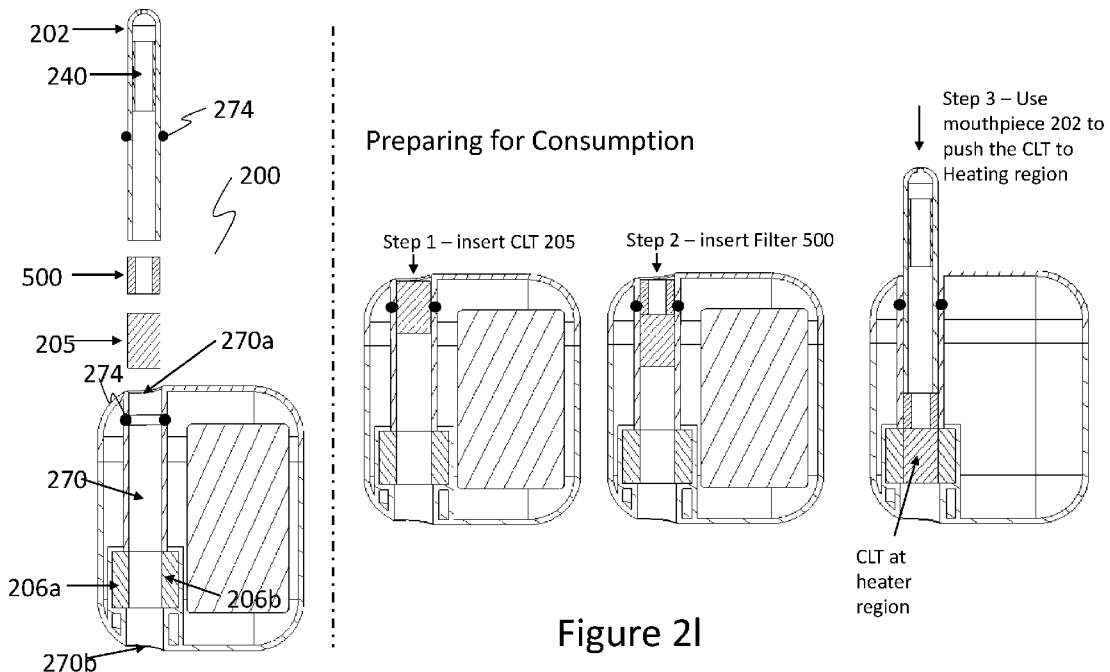

Figure 2

(57) Abstract: The disclosure relates to a heating device suitable for heating an aerosol generating substrate without combusting the aerosol generating substrate, the heating device comprises a mouthpiece adapted for a user to consume aerosol generated by the aerosol generating substrate; a substrate holder for receiving an aerosol generating substrate; a heating element shaped and dimensioned to heat the aerosol generating substrate to produce aerosol; an aerosol delivery channel positioned to receive aerosol generated from heating the aerosol generating substrate and to direct the aerosol towards the mouthpiece; and a filter holder for receiving at least one consumable filter, the filter holder positioned proximate the mouthpiece in a manner such as to filter particulates from the generated aerosol before consumption.



TN, TR, TT, TZ, UA, UG, US, UZ, VC, VN, WS, ZA, ZM, ZW.

- (84) Designated States** (*unless otherwise indicated, for every kind of regional protection available*): ARIPO (BW, GH, GM, KE, LR, LS, MW, MZ, NA, RW, SD, SL, ST, SZ, TZ, UG, ZM, ZW), Eurasian (AM, AZ, BY, KG, KZ, RU, TJ, TM), European (AL, AT, BE, BG, CH, CY, CZ, DE, DK, EE, ES, FI, FR, GB, GR, HR, HU, IE, IS, IT, LT, LU, LV, MC, MK, MT, NL, NO, PL, PT, RO, RS, SE, SI, SK, SM, TR), OAPI (BF, BJ, CF, CG, CI, CM, GA, GN, GQ, GW, KM, ML, MR, NE, SN, TD, TG).

Published:

- *with international search report (Art. 21(3))*
- *in black and white; the international application as filed contained color or greyscale and is available for download from PATENTSCOPE*

HEATING DEVICE, HEATING ELEMENT AND AEROSOL GENERATING PRODUCT

CROSS-REFERENCE TO RELATED APPLICATION

- 5 This application claims the benefit of priority to European patent application EP21165276.3 filed on 26 March 2021, the contents of it being hereby incorporated by reference in its entirety for all purposes.

TECHNICAL FIELD

- 10 **[0001]** The present disclosure relates to an aerosol generating product, a heating device, a heating element associated with heating the aerosol generating product.

BACKGROUND

- 15 **[0002]** The following discussion of the background is intended to facilitate understanding of the present disclosure. However, it should be appreciated that the discussion is not an acknowledgment or admission that any of the material referred to was published, known or a part of the common general knowledge in any jurisdiction as at the priority date of the application.

- 20 **[0003]** Many heat-not-burn devices and associated heating elements have been proposed. A typical heat-not-burn device comprises a heating device/element operable to heat an aerosol generating product having an aerosol generating substrate. The aerosol generating product may include tobacco material and one or more filter elements. In the case where the aerosol
25 generating product is replaced upon consumption of the tobacco material, the filter included in the replaced device may be wastefully disposed.

[0004] In addition, current heating devices comprise mouthpieces that may be heated such that when a user first consumes the generated aerosol, i.e. the 'first puff', the heated mouthpiece may inadvertently burn the lips of the user.

Further, the heat profile for heating the aerosol generating product may not be optimized for a good taste profile for the user's enjoyment.

5 [0005] There exists a need to develop a heating device, heating element and/or aerosol generating product that ameliorates the afore-mentioned drawbacks at least in part.

SUMMARY

10 [0006] According with one aspect of the disclosure, there is provided a heating device as defined in claims 1 to 9. According with another aspect of the disclosure, there is provided an aerosol generating product as defined in claims 10 to 14. According with another aspect of the disclosure, there is provided a two-segment and three-segment products with aerosol generating substrate as defined in claims 15 to 21.

15 [0007] It is contemplated that the various aspects may be combined in at least one way, for example in the form of a kit comprising an aerosol generating product as described and a heating device suitable for heating the aerosol generating product as described.

20 [0008] Other aspects of the disclosure will be apparent to those of ordinary skill in the art upon review of the following description of specific embodiments of the disclosure in conjunction with the accompanying drawings.

BRIEF DESCRIPTION OF THE DRAWINGS

[0009] Various embodiments are described, by way of example only, with reference to the accompanying drawings, in which:

25 [0010] Figure 1a to 1k illustrate various embodiments of a single-segment aerosol generating product.

[0011] Figures 2a to 2l illustrate a heating device for heating an aerosol generating product according to some embodiments of the present disclosure.

[0012] Figures 3a to 3d illustrate various embodiments of a heating element for use with the heating device illustrated in Figures 2a to 2l.

[0013] Figures 4a to 4e illustrate various embodiments of heating profiles associated with the heating element.

5 [0014] Figures 5a to 5c illustrate a filter unit for use with the heating device of Figures 2a to 2l and/or the aerosol generating product.

[0015] Figures 6a to 6f illustrate various embodiments of a jig for use with the heating device of any one of Figures 2a to 2k.

10 [0016] Figures 7a to 7m illustrate various embodiments of two-segment aerosol generating product.

[0017] Figures 8a to 8o illustrate various embodiments of a three-segment aerosol generating product.

15 [0018] Figure 9 show various shape profiles of a metallic tube for use with an aerosol generating product for better heat dissipation and/or aerosol taste enhancement.

[0019] Other arrangements are possible, and it is appreciable that the accompanying drawings are not to be understood as superseding the generality of the preceding description of the disclosure.

DETAILED DESCRIPTION

20 [0020] Embodiments are described with reference to the accompanying drawings. The terminology used herein is for the purpose of describing particular embodiments only and is not intended to limit the scope of the present disclosure. Other definitions for selected terms used herein may be found within the detailed description of the disclosure and apply throughout the description.

25 Additionally, unless defined otherwise, all technical and scientific terms used herein have the same meanings as commonly understood by one ordinary skilled in the art to which the present disclosure belongs. Where possible, the

same reference numerals are used throughout the figures for clarity and consistency.

[0021] Throughout the specification, unless the context requires otherwise, the word “comprise” or variations such as “comprises” or “comprising”, will be understood to imply the inclusion of a stated integer or group of integers but not the exclusion of any other integer or group of integers.

[0022] Throughout the specification, unless the context requires otherwise, the word “include” or variations such as “includes” or “including”, will be understood to imply the inclusion of a stated integer or group of integers but not the exclusion of any other integer or group of integers.

[0023] Throughout the specification, unless the context requires otherwise, the word “have” or variations such as “has” or “having”, will be understood to imply the inclusion of a stated integer or group of integers but not the exclusion of any other integer or group of integers.

[0024] Throughout the specification, unless the context requires otherwise, the term “tobacco” will be understood to include intermediate and/or final products prepared from a part of the tobacco plant, such as leaves, through the process of drying or curing, and further optional processes of aging, fermenting, flavorings etc., and to include any other products derived from any forms of tobacco leaves such as ground and reconstituted tobacco material.

[0025] Throughout the specification, the term “alloy” will be understood to refer to an admixture of metals and elements including, but not limited to, aluminum, copper, iron, magnesium, manganese, nickel, silicon, silver, tin, titanium, vanadium and zinc. The dominant or main component metal may be the metal having the highest percentage, in composition, relative to other elements.

[0026] Throughout the specification, the term “fiber” will be understood to depict a slender and substantially elongated shape.

[0027] Throughout the specification, the term “sheet” and “layer” will be understood to depict a planar surface with a substantially higher length and/or width compared to thickness. In addition, the term ‘layer’ can refer to single or multiple layers, with or without coating.

5 **[0028]** Throughout the specification, the term ‘wrapped’ or ‘unwrapped’ refers to a covering/non-covering of a unit. The cover is for purpose of maintaining a structural integrity of the unit.

[0029] Throughout the specification, the term ‘aerosol generating substrate’ refers to a substrate that, when heated, produces an aerosol or vapor suitable for consumption by a user. The aerosol generating substrate may include one or more layers and each layer can include tobacco and/or non-tobacco material.

10

[0030] Throughout the specification, the term ‘not-for-burn’ refers to a methodology of heating an aerosol generating substrate/product without combustion.

15 **[0031]** Throughout the specification, the term ‘acetate tow’ includes colored acetate tow.

[0032] According to an embodiment and with reference to Figure 1a there is an aerosol generating product 100 adapted for use with a not-for-burn device. Figure 1a(i) shows a perspective view of the product 100, Figure 1a (ii) shows a side view of the product 100 when viewed from a direction A, Figure 1a(iii) shows a side view of the product 100 when viewed from a direction B, and Figure 1a(iv) is a cross-sectional view of the product 100 seen from the direction B.

20

[0033] The aerosol generating product 100 may be directly inserted to a not-for-burn device, for example the not-for-burn device shown in Figure 2a to 2k. The aerosol generating product 100 may comprise at least one aerosol generating substrate 104 forming the core layer 102 of the product 100. An outer layer 106, in the form of a cover or wrapper may be arranged to at least partially surround the core layer 102 to provide structural integrity thereof. The

25

at least one aerosol generating substrate 104 comprises at least one of the following: a reconstituted tobacco sheet, a cast leaf tobacco sheet, tobacco powder, a cut tobacco roll, an acetate tow, a natural fiber, a natural leaf, a cellulose fiber, tobacco pellets, and derivatives thereof.

5 **[0034]** The outer cover 106 may be formed from or of acetate tow, fiber (including synthetic and natural fiber), cotton, fabric, mesh and/or paper (including coated paper).

[0035] The embodiment shown in Figure 1a comprises at least one intermediate layer 108 disposed between the outer layer 106 and the aerosol
10 generating substrate 104, and wherein the intermediate layer 108 comprises one or more of the following materials: - metal (including aluminum copper, in foil/sheet form or otherwise), alloy, reconstituted tobacco sheet, paper (including coated paper), plastic (including PLA, polypropylene such as biaxially-oriented polypropylene or BOPP), polymer, fiber (including natural
15 fiber) and ceramic. It is contemplated that additional intermediate layers 108 may be further disposed between the outer layer 106 and the aerosol generating substrate 104, each intermediate layer 108 may be formed of or from a material different from other intermediate layer 108. The aerosol
20 generating substrate 104 may include at least one of a tobacco material and a non-tobacco material. The core layer may also be single layered or multi-layered.

[0036] Another embodiment of the aerosol generating product 100, where like numerals reference like parts, is shown in Figure 1b.

[0037] Figure 1b(i) shows a perspective view of the product 100, Figure 1b
25 (ii) shows a side view of the product 100 when viewed from the direction A, Figure 1b(iii) shows a side view of the product 100 when viewed from the direction B, and Figure 1b(iv) is a cross-sectional view of the product 100 seen from the direction B.

[0038] Unlike the embodiment of Figure 1a, the core layer 102 is not completely or substantially filled with aerosol generating substrate 104, but further comprises a hollow portion 110 arranged adjacent to the aerosol generating substrate 104. In addition, there is an additional intermediate layer
5 112 that may be thicker compared to intermediate layer 108 arranged on the aerosol generating substrate.

[0039] Figure 1b(v) is an alternative to Figure 1b(iii) and shows a side view of the product 100 when viewed from the direction B. Figure 1b(vi) is an alternative to Figure 1b (iv) and is a cross-sectional view of the product 100
10 seen from the direction B. The hollow portion 110 shown in Figure 1b(v) and Figure 1b (vi) does not have the intermediate layer 112.

[0040] Another embodiment of the aerosol generating product 100, where like numerals reference like parts, is shown in Figure 1c. The embodiment shown in Figure 1c does not comprise a wrapping of outer layer 106. Instead,
15 the intermediate layer 108 comprising at least one of metal (including aluminum copper, in foil/sheet form or otherwise), alloy, reconstituted tobacco sheet, paper (including coated paper), plastic (including PLA, polypropylene such as biaxially-oriented polypropylene or BOPP), polymer, fiber (including natural fiber) and ceramic is the outer layer. In other words, in the embodiment shown
20 in Figure 1c, the layer 108 may form an outer layer where there is only one layer, and may form both the outer layer and intermediate layer where there are two or more layers. For example, the outer layer may be formed of coated paper and the intermediate layer be formed from a metal alloy, such as an aluminum alloy.

[0041] Another embodiment of the aerosol generating product 100, where like numerals reference like parts, is shown in Figure 1d. The embodiment shown in Figure 1d comprises a relatively thicker outer layer 106 and a relatively thinner aerosol generating substrate layer 104. The embodiment of Figure 1c is without an intermediate layer 108 or 112.
25

[0042] Figure 1d(i) shows a perspective view of the product 100, Figure 1d(ii) shows a side view of the product 100 when viewed from the direction A, Figure 1d(iii) shows a side view of the product 100 when viewed from the direction B, and Figure 1d(iv) is a cross-sectional view of the product 100 seen from the direction B.

[0043] The core layer 102 of the embodiment of Figure 1d comprises a through hollow 114. In the case of a through hollow 114, the core layer 102 may be regarded as a core region/central area with no material or layer formed therein. The aerosol generating substrate 104, in the form of reconstituted tobacco sheet, is layered on the outer perimeter/circumference of the core layer 102. The outer layer 106, in the form of acetate tow, fiber (including synthetic and natural fiber), cotton, fabric, mesh and/or paper (including coated paper), is layered on the reconstituted tobacco sheet.

[0044] Another embodiment of the aerosol generating product 100, where like numerals reference like parts, is shown in Figure 1e. The embodiment shown in Figure 1e comprises an outer layer 106 in the form is without an intermediate layer 108 or 112.

[0045] Figure 1e (i) shows a perspective view of the product 100, Figure 1e (ii) shows a side view of the product 100 when viewed from the direction A, Figure 1e (iii) shows a side view of the product 100 when viewed from the direction B, and Figure 1e (iv) is a cross-sectional view of the product 100 seen from the direction B.

[0046] The core layer 102 of the embodiment of Figure 1e comprises a through hollow 114. The aerosol generating substrate 104, in the form of tobacco powder, is dispersed throughout the outer layer 106. The outer layer 106 comprises acetate tow, fiber (including synthetic and natural fiber), cotton, fabric, mesh and/or paper (including coated paper) as the base material and the tobacco powder may be coated onto the acetate tow.

[0047] Another embodiment of the aerosol generating product 100, where like numerals reference like parts, is shown in Figure 1f. The embodiment shown in Figure 1f comprises an outer layer 106 in the form that is without an intermediate layer 108 or 112.

5 **[0048]** Figure 1f (i) shows a perspective view of the product 100, Figure 1f (ii) shows a side view of the product 100 when viewed from the direction A, Figure 1f (iii) shows a side view of the product 100 when viewed from the direction B, and Figure 1f (iv) is a cross-sectional view of the product 100 seen from the direction B.

10 **[0049]** The embodiment shown in Figure 1f has no hollow portion 114. In addition, there is a single core layer 102 comprising acetate tow as the base material. The aerosol generating substrate 104, in the form of tobacco powder, is dispersed throughout the core layer 102.

[0050] Another embodiment of the aerosol generating product 100, where
15 like numerals reference like parts, is shown in Figure 1g.

[0051] Figure 1g (i) shows a perspective view of the product 100, Figure 1g (ii) shows a side view of the product 100 when viewed from the direction A, Figure 1g (iii) shows a side view of the product 100 when viewed from the direction B, and Figure 1g (iv) is a cross-sectional view of the product 100 seen
20 from the direction B. The core layer 102 of the embodiment of Figure 1f comprises through hollow 114. The aerosol generating substrate 104, in the form of reconstituted tobacco sheet, is layered on the through hollow 114. The intermediate layer 108 is formed from or of acetate tow, fiber (including synthetic and natural fiber), cotton, fabric, mesh and/or paper (including coated
25 paper). The outer layer 106 may be a single layer with paper, or multi-layer including material such as metal (including aluminum copper, in foil/sheet form or otherwise), alloy, reconstituted tobacco sheet, paper (including coated paper), plastic (including PLA, polypropylene such as biaxially-oriented polypropylene or BOPP), polymer, fiber (including natural fiber) and ceramic.

[0052] Another embodiment of the aerosol generating product 100, where like numerals reference like parts, is shown in Figure 1h.

[0053] Figure 1h (i) shows a perspective view of the product 100, Figure 1h (ii) shows a side view of the product 100 when viewed from the direction A, Figure 1h (iii) shows a side view of the product 100 when viewed from the direction B, and Figure 1h (iv) is a cross-sectional view of the product 100 seen from the direction B.

[0054] The core layer 102 of the embodiment of Figure 1h comprises through hollow 114. The aerosol generating substrate 104, in the form of tobacco powder, is dispersed on the intermediate layer 108. The intermediate layer 108 is formed from or of acetate tow, fiber (including synthetic and natural fiber), cotton, fabric, mesh and/or paper (including coated paper). The outer layer 106 may be a single layer with paper, or multi-layer including material such as metal (including aluminum copper, in foil/sheet form or otherwise), alloy, reconstituted tobacco sheet, paper (including coated paper), plastic (including PLA, polypropylene such as biaxially-oriented polypropylene or BOPP), polymer, fiber (including natural fiber) and ceramic.

[0055] Another embodiment of the aerosol generating product 100, where like numerals reference like parts, is shown in Figure 1i.

[0056] Figure 1i (i) shows a perspective view of the product 100, Figure 1i (ii) shows a side view of the product 100 when viewed from the direction A, Figure 1i (iii) shows a side view of the product 100 when viewed from the direction B, and Figure 1i (iv) is a cross-sectional view of the product 100 seen from the direction B.

[0057] The core layer 102 of the embodiment of Figure 1i comprises acetate tow. The aerosol generating substrate 104, in the form of tobacco powder, is dispersed on the core layer 102. The outer layer 106 may be a single layer with paper, or multi-layer including material such as metal (including aluminum, copper, in foil/sheet form or otherwise), alloy, reconstituted tobacco sheet,

paper (including coated paper), plastic (including PLA, polypropylene such as biaxially-oriented polypropylene or BOPP), polymer, fiber (including natural fiber) and ceramic.

5 **[0058]** It is appreciable that Figure 1h and 1i may be without tobacco powder. In such cases, the aerosol generating substrate 104 may form part of the outer layer 106 or the intermediate layer 108.

[0059] Figure 1j and 1k shows preform shapes in various forms. The aerosol generating substrate is held together by binding agents and compressed by pressure to form these shapes.

10 **[0060]** It is appreciable that with the embodiments depicted in Figures 1a to 1k, a skilled person will envisage acetate tow to be used as an outer layer 106, as a base material forming part of the core layer 102, and/or as base material forming part of the intermediate layer 108.

15 **[0061]** In some embodiments, the outer layer 106 or wrapper comprises at least one layer of paper, metal, alloy, reconstituted tobacco sheet, cast leaf tobacco (CLT) sheet, acetate tow, heat stick wrapper plastic (including PLA, polypropylene such as biaxially-oriented polypropylene or BOPP), polymer, fiber (including natural fiber) and ceramic. If the wrapper is a metal, the metal may include aluminum or copper in a foil form.

20 **[0062]** In some embodiments, the aerosol generating product is a cylindrical rod having a length in a range from 5mm to 250mm.

25 **[0063]** In some embodiments, the single segment comprises a base ingredient having at least one of Propylene Glycol (PG) and Vegetable Glycerine/Glycerin (VG). Where both PG and VG are present, their total amount is less than 20 milligrams. In some embodiments, the ratio of PG: VG is 1:1.

[0064] In some embodiments, the aerosol generating product 100 may have an overall planer shape, i.e. having a dimension, such as thickness, much

smaller than other dimensions, such as length and width. In some embodiments, the planar shape is a prism or cylindrical shape.

[0065] The aerosol generating product 100 may be casted, molded, or shaped, formed by rolling, pressing, stamping, formed by injection or extruding, reconstituting or combinations of one or more of the above, and any other process. The form of the aerosol generating substrate 102 may be one of the following: cut rag, compacted into shape, powder, dust, flakes, pellet, granules, tablet, pill, paper, block, porous block, sheet, net, fibers, fibers woven into sheet, slices, ribbons or combinations thereof. The aerosol generating product 100 may be designed for products made from loose tobacco/flavored non-tobacco and rolling paper (such as, but not limited to, roll your own (RYO) products) or other heat-not-burn devices. The aerosol generating product 100 may be configured in the form of a capsule.

[0066] It is appreciable that the embodiments depicted in Figures 1a to 1j are single segment aerosol generating products. Such single segments are advantageously compact and may be used with the heating device 200.

[0067] According to another aspect and as shown in Figure 2 (Figure 2a to 2k), there is a heating device 200 suitable for heating an aerosol generating substrate or product. The heating device 200 comprises a suction portion 202 in the form of a mouthpiece/nose-piece 202 allowing a user to consume aerosol generated by the aerosol generating substrate; a substrate holder 204 for receiving an aerosol generating substrate, a heating element 206 shaped and dimensioned to heat the aerosol generating substrate to produce aerosol; an aerosol delivery channel 208 positioned to receive aerosol generated from heating the aerosol generating substrate and to direct the aerosol towards the mouthpiece/nose-piece 202.

[0068] The heating device 200 may be powered by electrical power, using a battery 214 that is contained within the heating device 200. The battery 214 may be a lithium-ion polymer (LiPo) battery. A charging port 216 may be provided in the device 200 to charge the LiPo battery. The charging port 216

may be a USB-type charging port or may be other known charging ports (including wireless charging ports). The battery 214 may be electrically connected to the heating element 206 such as to increase the temperature of the heating element 206 to a desired temperature or temperature profile.

5 **[0069]** Due to the generation of heat of the heating element 206, heat sinking areas or regions may be provided within the device 200. The heat sinking areas may comprise one or more metal or alloy coatings, plates and/or holders 240 positioned in a manner such as to reduce heat within the device 200.

10 **[0070]** In some embodiments, heat sinks in the form of fin-like structures may be positioned at a region proximate the mouthpiece/nose-piece 202. The heat sinks may be formed from manufacturing methods such as, but not limited to, extrusion, diecasting, machining process, 3D printing, investment casting and injection molding.

15 **[0071]** There may comprise a heat insulation region in the form of one or more walls 209 surrounding the substrate holder 204 to insulate heat generated from the substrate holder 204 to prevent minimize heat transfer to the surface of the device 200. The heat insulation wall 209 may be positioned adjacent the heat sink 207 so as to dissipate heat away from the substrate holder 204 and insulate heat from the surface of the device 200.

20 **[0072]** Referring to the embodiment shown in Figure 2a, the device 200 may comprise a jig 250 as an alternative to substrate holder 204 for receiving an aerosol generating product and/or at least one filter unit. The aerosol generating product may be the single-segment aerosol generating product 100. The jig 250 may comprise or may house a metal hollow or cup-shaped cylinder 207 to hold
25 the aerosol generating product such that the cylinder 207 can be made of aluminum, copper, magnesium, stainless steel or other conductive material to dissipate heat away from the generated aerosol. The jig 250 may be adjustable for the length of the aerosol generating product for ease of insertion and removal of the aerosol generating product from the substrate holder 204. The
30 jig may comprise a filter holder 210 for receiving at least one filter 212, the filter

holder 210 positioned proximate the mouthpiece 202 in a manner such as to filter particulates from the generated aerosol before consumption by the user. The heating element 206 may have a sliding mechanism 213 such that the heating element 206 can be adjusted to move up and down to heat the aerosol generating product of different lengths. The sliding mechanism 213 may have biasing mechanisms as known to a skilled person to bias the element 206 at different positions to adapt to different aerosol generating product.

[0073] In the embodiment of Figure 2a, the portion of the device 200 receiving the jig may be lined with insulation 244 (see Figure 2a(iii)), in the form of material such as plastic, metal, fiber, glass, ceramic, carbon, aerogel, etc. to insulate the heat generated from the heating element 206. As an alternative, the insulation 244 may comprise a vacuum chamber surrounding the heating element and/or the jig 250.

[0074] It is appreciable that the base of the jig may comprise a slot or hole for insertion of heat element to contact the aerosol generating product 100. When inserted, the aerosol generating product 100 is clamped between the jig 250 and the receiving portion 246 to prevent leakage of air. The receiving portion 246 may comprise two or more biasing mechanisms such that when the jig 250 is inserted, a force is exerted on the jig 250 to hold the jig 250 securely within the device 200. In operation, air may enter the device 200 from any air gaps 224 formed around the jig 250.

[0075] Referring to Figure 2b, which shows another embodiment of the device 200 comprising two parts 200a and 200b. The first part 200a which may be referred to as a device cap, houses the aerosol delivery channel 208, filter holder 210 (with filter 212 when present), substrate holder 204 (with substrate 205 when present). The second part 200b may be referred to as a device body, houses the battery 214, the charging port(s) 216, any pin reset/actuators for operating the device 218, and the heat sink(s) 240. In the embodiment shown in Figure 2b, the aerosol delivery channel 208 is a U-shaped channel arranged to connect an air pocket 220 (also referred to as an airflow pocket) located

adjacent to the substrate holder 204 to the filter holder 210. Figure 2c is a cross-section view showing the device of Figure 2b in operation, with the aerosol generating substrate 205 contacting the heating element 206, and the filter 212 held in place by the filter holder 210.

5 **[0076]** When parts 200a and 200b are connected and the device 200 is operated via the use of actuator(s) 218, the heating element 206 is heated to a desired temperature. Consequently, the substrate 205, and the air surrounding the substrate within the air pocket 220 is heated. Air from the exterior of the device 200 is drawn into the device from around one or more air gaps/inlets 224
10 defined at the interface between the parts 200a, 200b, towards the substrate 205. The air flowing towards the substrate 205 may simultaneously be heated with the substrate 205, and may then flow pass the heat sinks 240, thereby reducing the temperature of the same. The air drawn to the substrate 205 carries aerosol generated via heating the substrate 205 towards the air pocket
15 220, and then to the U-shaped aerosol delivery channel 208. The aerosol delivery channel 208 may be coated with a layer of metal, such as aluminium, copper, magnesium, stainless steel or other conductive material (which effectively forms a heat sink) to extract heat away from the aerosol flowing pass the aerosol delivery channel 208 before entering the mouthpiece 202. The heat
20 sink(s) 240, positioned adjoining the aerosol delivery channel 208, further aids to dissipate heat away from the aerosol delivery channel 208.

[0077] Figure 2d shows another embodiment of the device 200. Instead of a two-part configuration shown in Figure 2b and 2c, the part 200a may further comprise parts 200a1 and 200a2. Such an arrangement advantageously
25 provides for a cover for easy replacement of a filter 212. Part 200a1 may be a referred to as a device cover, and part 200a2 a device cap. In conjunction part 200a1 and part 200a2 house the aerosol delivery channel 208, filter holder 210 (with filter 212 when present), substrate holder 204 (with substrate 205 when present). The second part 200b may be referred to as a device body, houses
30 the battery 214, the charging port(s) 216, any pin actuators (including actuators for reset, on/off, operational control) for operating the device 218, and the heat

sink(s) 240. In the embodiment shown in Figure 2d, the aerosol delivery channel 208 is a straight channel and may be analogous to the air pocket 220 located adjacent to the substrate holder 204 to the filter holder 210. A singular piece of heat sink 240 comprising one or more metal, such as aluminium, copper, magnesium, stainless steel or other conductive material may be positioned proximate or adjoining the aerosol delivery channel 208 and the substrate holder 204 to aid dissipation of heat away from the aerosol delivery channel 208. In the embodiment shown in Figure 2d, the mouthpiece 202 may be coated with a layer of metal, such as aluminium, copper, magnesium, stainless steel or other conductive material (which effectively forms a heat sink) to extract heat away from the aerosol flowing pass the mouthpiece 202.

[0078] Figure 2e is a cross-sectional view showing the device of Figure 2d in operation, with the aerosol generating substrate 205 contacting the heating element 206, and the filter 212 held in place by the filter holder 210.

[0079] When parts 200a and 200b are connected and the device 200 is operated via the use of actuator(s) 218, the heating element 206 is heated to a desired temperature. Consequently, the substrate 205, and the air surrounding the substrate within the aerosol delivery channel 208 (air pocket 220) is heated. Air from the exterior of the device 200 is drawn into the device from around one or more air gaps/inlets 224 defined at the interface between the parts 200a, 200b towards the substrate 205. The air flowing towards the substrate 205, that may simultaneously be heated, may flow pass the heat sink(s) 240, thereby reducing the temperature of the same. The air drawn to the substrate 205 carries aerosol generated via heating the substrate 205 towards the air pocket 220, and then to the aerosol delivery channel 208 adjoining the substrate holder 204. The heat sink 240, positioned adjoining the aerosol delivery channel 208, further aids to dissipate heat away from the aerosol delivery channel 208.

[0080] Figure 2f is another embodiment of the device 200. Instead of a U-shaped aerosol delivery channel or a straight delivery channel 208, the aerosol delivery channel shown in Figure 2f is Z-shape. The embodiment of Figure 2f

also shows the part 200a housing the substrate holder 204 only, with other components housed by the part 200b. The substrate holder 204 may be shaped and dimensioned as a hollow tube for receiving a corresponding substrate 205 within the holder. To facilitate proper airflow within the device 200, mechanical gaskets such as O-rings 260 maybe positioned at various joints. The cup-like or cylinder structure 207 may line the substrate holder 204 to receive the substrate 205.

[0081] Figure 2g is a cross-sectional view showing the device of Figure 2f in operation, with the aerosol generating substrate 205 contacting the heating element 206, and the filter 212 held in place by the filter holder 210.

[0082] When parts 200a and 200b are connected and the device 200 is operated via the use of actuator(s) 218, the heating element 206 is heated to a desired temperature. Consequently, the substrate 205, and the air surrounding the substrate within the aerosol delivery channel 208 (air pocket 220) is heated. Air from the exterior of the device 200 is drawn into the device from around one or more air gaps/inlets 224 defined at the interface between the parts 200a, 200b towards the substrate 205. The air drawn to the substrate 205 carries aerosol generated via heating the substrate 205 towards the air pocket 220, which forms part of the aerosol delivery channel 208 adjoining the substrate holder 204. A layer of metal is coated over part of the aerosol delivery channel 208 to facilitate heat transfer. One or more heat sink(s) 240, positioned adjoining the aerosol delivery channel 208, further aids to dissipate heat away from the aerosol delivery channel 208.

[0083] It is contemplated that various features of the embodiments shown in Figure 2b, 2d and 2f may be combined. As a non-limiting example, the aerosol delivery channel 208 and the mouthpiece 202 of each embodiment may both be coated with conductive material to form yet further embodiments. As another example, O-rings 260 or other suitable gaskets may be positioned in the devices 200 as shown in Figure 2b and 2d.

[0084] In the embodiments shown in Figures 2a to 2k, the coating over the aerosol delivery channel and/or mouthpiece may be regarded as a first heat conductor. The metallic plates proximate the aerosol delivery channel may be regarded as a second heat conductor operable to dissipate heat away from the first heat conductor.

[0085] Figure 2h shows an embodiment having an external profile similar to the device shown in Figure 2d. The device cover 200a1 may be rotatable with respect to device cap 200a2 to removably detach the device cover 200a1 from the device cap 200a2. The device cap 200a2 comprises a slot for receiving the jig 250, except that in the embodiment shown in Figure 2h the mouthpiece 202 is not part of the jig 250. A compartment of the jig 250 for receiving the aerosol generating substrate may be lined/coated with suitable heat conducting material.

[0086] Figure 2i illustrates an embodiment of the jig 250, wherein the part of the jig 250 receiving the aerosol generating substrate allows for excess material to be pushed out from the substrate when in use. Suitable openings/gaps are formed on the jig 250 so as to allow for the excess material to be pushed out of the jig 250.

[0087] Figure 2j illustrates another embodiment that is suitable for use with the various embodiments in Figure 2a to 2i, wherein heat sinks in the form of fin-like structures may be positioned at a region proximate the mouthpiece/nose-piece 202. The heat sinks may be formed from manufacturing methods such as, but not limited to, extrusion, diecasting, machining process, 3D printing, investment casting and injection molding.

[0088] Figure 2k illustrates embodiments wherein the region/walls surrounding the heating element 206 may be coated/layered with metal, such as aluminium, copper, stainless steel, or alloy 252 in the form of fibre, strips, sheet, chips, powder or granules. The outer surface of the device 200, i.e. the surface coming into direct contact with the environment, may be formed from or of a metal or alloy, such as aluminum alloy, or plastic.

[0089] Figure 2I shows another embodiment of device 200, comprising a through-hollow or through-hole 270 spanning across the device 200, the through-hole 270 includes both the aerosol delivery channel 208 and substrate holder 204, wherein a first end 270a of the through-hole 270 is dimensioned to slidably receive the suction portion 202, an aerosol generating substrate 205, and/or a filter unit 212.

[0090] In the embodiment shown in Figure 2I, the heating element 206 may be a cylindrical hollow surrounding a part of the through-hole 270. As seen from the cross-sectional view, there comprises cross-sectional side 206a and second cross-sectional side 206b configured to conduct heat via the through-hole 270 to heat the aerosol generating substrate 205 when the aerosol generating substrate 205 is positioned within the through-hole 270 and at a position corresponding with the hollow portion of the cylindrical hollow. From the cross-sectional view, the aerosol generating substrate 205 is positioned between the cross-sectional side 206a and second cross-sectional side 206b.

[0091] It is contemplated that a user may insert the aerosol generating substrate 205 via the first end 270a of the through-hole 270. The suction portion 202 may be shaped and dimensioned to urge the aerosol generating substrate 205 toward a position between the first cross-sectional side 206a and second cross-sectional side 206b.

[0092] The through-hole 270 may be dimensioned to receive a filter unit 500, wherein the filter unit 500 is positioned in operation such that heated aerosol is directed pass the filter unit 500 before reaching the suction portion 202.

[0093] The heating device 200 of claim 5, wherein the through-hole 270 comprises a second end 270b for at least one of the aerosol generating substrate 205 and filter unit 500 to be urged out of the through-hole 270 after consumption.

[0094] As an alternative or in addition to the various heat sink configurations as described, one or more temperature sensors may be positioned in the device 200 to provide feedback on the aerosol temperature. The feedback may then be sent to a controller (not shown) for the provision of temperature control in accordance with one or more heating profiles (see Figures 4a to 4e). The controller may be in the form of an integrated circuit chip (IC), such as, but not limited to, an application specific integrated circuit (ASIC) chip. Such an arrangement advantageously facilitates dynamic control by the controller of the heating profile of the heating element 206 and may optimize power consumption of energy.

[0095] It is appreciable that the devices 200 work on the principle to separate an aerosol generating substrate (e.g. tobacco), from the filter. This is especially suited for a single segment embodiment of the aerosol generating product 100. For an aerosol generating product 100 having segments including a filter, the additional filter 212 may not be required in operation and the slot 210 may be left empty.

[0096] In some embodiments, the aerosol delivery channel 208 and/or mouthpiece may be coated with heat dissipation material or heat sink. A suitable material may be a metal or alloy, such as an aluminium alloy, magnesium, stainless steel or other conductive material to extract heat away from the mouthpiece 202.

[0097] Figures 3a to 3c show various embodiments of heating elements for use with a heating device, such as, but not limited to heating device 200 to heat at least one aerosol generating substrate without combustion of the at least one aerosol generating substrate, such as, but not limited to aerosol generating substrate 102, wherein the heater element 302 is shaped and dimensioned to be in thermal contact with the at least one aerosol generating product. Figure 3d shows various embodiments where at least one heating pin 314 is positioned adjacent to the heater element 302 to provide homogenous temperature control within the aerosol generating product, the at least one heating pin 314 is formed

from or of a metal, an alloy, ceramic, nickel plating, and silver, or other composite material with or without coating. The heating pin 314 may be shaped and dimensioned as having a substantially thinner width compared to the heater element 302.

5 **[0098]** The heating element can comprise an elongate body portion, a first end 304 adapted to receive electrical power, and a second end adapted to provide optimum contact with the aerosol generating substrate.

[0099] In some embodiments, the second end 306 of the heating element comprises a rounded tip or a tapered tip. The tapered tip 306 may be a frusto-
10 conical tip or may comprise one or more chamfered surfaces, or a circular cross-section with at least two indented portions. The inside of the tip 306 may be hollow or partially hollow. The internal of the elongate body portion may be hollow or partially hollow.

[00100] In some embodiments, the elongate body portion of the heating
15 element has a at least one of a L-shaped cross-section, a V-shaped cross-section, a phi-shaped cross-section, a C-shaped cross-section, a J-shaped cross-section, an X-shaped cross-section, a Y-shaped cross-section, a T-shaped cross-section, a triangular-shaped cross-section or a rectangular-shaped cross-section.

20 **[00101]** In some embodiments of the heating element, the heating element has a coin or planar shape 308. In other embodiments, the heating element has a cylindrical profile 310 such that an inner surface of the cylinder is in thermal contact with the aerosol generating product 102. In some embodiments, the heating may be effected by an inductor or inductor element. In some
25 embodiments, the heating element has a tube profile 320, which may be viewed as similar in shape as the cylindrical profile 310 with a base portion removed to form a through-hollow.

[00102] In some embodiments of the heating element, the body portion is formed from or of aluminium. In other embodiments, the body portion may be form of/from other materials such as glass/glass fiber.

5 **[00103]** While the heating element shown in Figures 3a to 3c are in the form of an elongate tube and can be hollow to receive electrical circuitry or substrate, it is appreciable that other shapes and sizes may be contemplated to receive aerosol generating substrate of different shapes and sizes.

10 **[00104]** According to another aspect of the disclosure there is a controller for use with a heating device, such as a heating device 200 as described in Figures 2a to 2k. The controller may include sensors for sensing a temperature and/or pressure of the heating element of the heating device. Alternatively, the heating device may include one or more of the sensors.

15 **[00105]** The pressure sensor may be configured for sensing a pressure corresponding to a suction force exerted on a mouthpiece of the heating device. The suction force may in turn correspond with a user consuming the aerosol via his/her mouth (i.e. 'taking a puff'). To heat the heating element, an electrical circuit may be arranged to directly send electrical current to the heating element or to induce electrical current flowing through the heating element.

20 **[00106]** It is contemplated that in operation, the controller may be arranged to raise the temperature from room temperature to achieve a first resting temperature and a first operating temperature, wherein the first operating temperature is associated with the suction force detected by the pressure sensor.

25 **[00107]** Figures 4a to 4e show five heating profiles corresponding various resting temperatures and operating temperatures.

[00108] Figure 4a shows the controller programmed to provide a first heating profile. The first heating profile comprises the first resting temperature at between 200 degrees Celsius (°C) and 400°C, and the first operating temperature above 200°C and up to 400 °C. In operation the heating element

is heated from room/ambient temperature to the first resting temperature. When the pressure detects that a suction force is applied on the mouthpiece 202, the controller operates to heat the heating element to an operating temperature of up to 400 °C. When the suction force is no longer applied, the temperature of the heating element falls back to the first resting temperature. This process repeats itself until reset or the aerosol generating substrate is consumed. In the embodiment shown in Figure 4a, the first resting temperature may be in a range from 300°C to 350°C.

[00109] Figure 4b shows the controller programmed to provide a second heating profile. The second heating profile comprises the first resting temperature at a temperature range of 250 °C to 400 °C, and the first operating temperature lower than the first resting temperature and at a temperature in a range of 200 °C to 350 °C, and a second resting temperature above the first operating temperature, the second resting temperature below the first resting temperature. In operation the heating element is heated from room/ambient temperature to the first resting temperature. When the pressure detects that a suction force is applied on the mouthpiece 202, the controller operates to cool the heating element to an operating temperature of around 200 °C. When the suction force is no longer applied, the temperature of the heating element rises to the first resting temperature. However, after a predetermined number of 'puffs' taken by the user, the temperature of the heating element is maintained at a second resting temperature regardless of whether subsequent suction force is detected by the pressure sensor. The predetermined number of 'puffs' may be three puffs, and the second resting temperature may be a temperature below the first resting temperature but higher than the first operating temperature.

[00110] Figure 4c shows the controller programmed to provide a third heating profile. The third heating profile comprises the first resting temperature at a range from 200 degrees Celsius (°C) to 400°C, a second resting temperature below the first resting temperature at above 200 °C, the first operating temperature less than the first resting temperature and at least 200 °C, and a

second operating temperature above the second resting temperature up to 400 °C. In operation the heating element is heated from room/ambient temperature to the first resting temperature. When the pressure detects that a suction force is applied on the mouthpiece 202, the controller operates to cool the heating element to an operating temperature of around 200 °C. When the suction force is no longer applied, the temperature of the heating element rises to the first resting temperature. However, after a predetermined number of 'puffs' (e.g. 3) taken by the user, the temperature of the heating element drops to the second resting temperature. When the user takes further/subsequent puffs, the controller operates to heat the heating element to an operating temperature of up to 400 °C, and the second resting temperature is at a temperature below the first resting temperature but higher than the first operating temperature. It may be appreciable that the third heating profile may be regarded as a combination of the second heating profile and the first heating profile.

15 **[00111]** Figure 4d shows the controller programmed to provide a fourth heating profile. The fourth heating profile may comprise the first resting temperature at a range from 200 degrees Celsius (°C) to 400°C, the first operating temperature above the first resting temperature and up to 400 °C, and a second operating temperature above 200°C and below the first resting temperature. In operation the heating element is heated from room/ambient temperature to the first resting temperature. When the pressure detects that a suction force is applied on the mouthpiece 202, the controller operates to increase the heating element to an operating temperature of around 400 °C. When the suction force is no longer applied, the temperature of the heating element drops to the first resting temperature. However, after a predetermined number of 'puffs' (e.g. 3) taken by the user, subsequent puffs result in a temperature drop of the heating element below the first resting temperature and a release of suction force result in an increase of temperature to the first resting temperature. It may be appreciable that the fourth heating profile may be regarded as a combination of the first heating profile and the second heating profile.

[00112] Figure 4e shows the controller programmed to provide a fifth heating profile. The fifth heating profile may comprise the first resting temperature at a range from 200 degrees Celsius (°C) to 400°C, and a first operating temperature above the first resting temperature and up to 400 °C. In operation
5 the heating element is heated from room/ambient temperature to the first resting temperature. When the pressure detects that a suction force is applied on the mouthpiece 202, the controller operates to increase the heating element to an operating temperature of around 400 °C. When the suction force is no longer applied, the temperature of the heating element is maintained at the
10 operating temperature.

[00113] . It is appreciable that the temperature of 200 °C and/or 400°C are arbitrary. Other resting and operating temperatures having similar profiles as one of the five heating profiles as described may be contemplated.

[00114] It is appreciable that in some embodiments the controller may control
15 the heating profiles of the heating element by logical instructions or software programs pre-loaded into the controller. In some embodiments, the controller may control the heating profiles of the heating element dynamically based on input and feedback from the temperature sensors and pressure sensors placed in the heating device (e.g. device 200) to track the actual temperature and
20 pressure of the aerosol.

[00115] It is appreciable that one or more of the various heating profiles, to the extent they do not contradict in operation, may be combined and preloaded into the controller.

[00116] Figure 5a shows a filter unit 500 suited for use with the heating
25 device described in the previous embodiments. The filter unit 500 comprises a core layer 502, an outer layer 504 and an intermediate layer 506 sandwiched between the core layer 502 and the outer layer 504. In the embodiment shown in Figure 5a, the core layer 502 and outer layer 504 are formed from or of materials comprising acetate tow, fiber (including synthetic and natural fiber),
30 cotton, fabric, mesh and/or paper (including coated paper). The intermediate

layer 506 may comprise a single layer with paper or a multi-layered structure including materials such as metal (including aluminum copper, in foil/sheet form or otherwise), alloy, reconstituted tobacco sheet, paper (including coated paper), plastic (including PLA and BOPP), polymer, fiber (including natural
5 fiber) and ceramic. The filter unit 500 may be shaped and dimensioned as a rod. It is appreciable that the various layers may be arranged coaxially with respect to each other.

[00117] Figure 5b shows a variant of Figure 5a having the core layer 502 partially hollow, defining a hollow portion 510. There further comprises another
10 intermediate layer 512 arranged between the core layer 502 and the intermediate layer 506. It is to be appreciated that the intermediate layer 512 may or may not extend to the hollow portion 510. Figure 5c illustrate another variant of Figure 5a wherein the core layer 502 is partially hollow, defining a hollow portion 510. Unlike the embodiment shown in Figure 5b, the embodiment
15 shown in Figure 5c does not have the intermediate layer 512.

[00118] Figure 6 (6a to 6f) relate to a substrate holder 600, also referred to as a jig, for use one or more of the heating devices 200, in particular the embodiment shown in Figure 2a.

[00119] The substrate holder 600 may be configured to hold different one or
20 more single-segment aerosol generating product including as shown in Figures 1a to 1k, one or more two-segment aerosol generating product including as shown in Figures 7a to 7l, one or more three-segment aerosol generating product including as shown in Figures 8a to 8n, and/or one or more filter segments including as shown in Figures 5a, 5b and 5c. The substrate holder
25 600 comprises a mouthpiece 602, an elongate structure 604 comprising a plurality of compartments 606, and an end portion 608 arranged distally with respect to the mouthpiece 602.

[00120] Figure 6a shows a substrate holder 600 having a first compartment 610 positioned proximate the distal end portion 608 and one or more second
30 compartments 612 adjacent the mouthpiece 602. The first compartment 610 is

shaped and dimensioned to receive a single-segment aerosol generating product including as shown in any one of Figures 1a to 1k, two-segment aerosol generating product including as shown in Figures 7a to 7l, or three-segment aerosol generating product including as shown in Figures 8a to 8n. On the end portion 608 is formed a through-hole such that in operation, a heating element of the heating device 200 can contact the single-segment aerosol generating product 100 to generate aerosol therefrom. The first compartment 610 may be coated or installed with one or more heat conductors 614. The one or more heat conductors 614 may be shaped and dimensioned to be inserted into the first compartment 610 without hindering the first compartment 610 ability to receive the single-segment aerosol generating product.

[00121] The one or more second compartments 612 are shaped and dimensioned to receive a filter unit including as shown in Figures 5a, 5b and 5c and/or a heat dissipation tube 618. The heat dissipation tube 618 may be an aluminum tube. Where there are a plurality of second compartments 612 and the heat dissipation tube 618 is placed in one compartment of the plurality of second compartments 612, the filter unit will have to be placed in another compartment of the plurality of second compartments 612.

[00122] In between the first compartment 610 and the second compartment 612 there are one or more third compartments 616. The third compartment(s) 616 function as a connecting portion between the first compartment 610 and the second compartment 612, and may typically be formed of or from less material compared to the first compartment 610 and the second compartment(s) 612, as the third compartment 616 does not receive any aerosol generating product(s) or filter unit(s). The less material associated with the third compartment 616 advantageously reduce heat transfer to the second compartment(s) 612.

[00123] In the embodiment shown in Figure 6a, there comprise one first compartment 610, two second compartments 612, and one third compartment 616.

[00124] Figure 6b shows another embodiment of the jig with one first component 610 and three second compartments 612. There is no third compartment 616 in the embodiment of Figure 6b. At least one of the three second compartments 612 function as the connector between the first
5 compartment 610 and the other second compartment 612.

[00125] It is to be appreciated that there can be four or more second compartments 612. In some embodiments, one or more second compartments 612 can be enclosed or covered. The covered or enclosed second compartments 612 can contain the aluminum tube 618.

10 **[00126]** Figure 6c to 6f show various embodiments of the jig 600 wherein there are different configurations/positioning of an aluminum tube 618 or other heat conductive metal or metal alloy, the aerosol generating substrate, and the filter unit.

[00127] Figure 7 (7a to 7l) show various embodiments of a two-segment
15 aerosol generating product 700. The product 700 can incorporate any one of the single-segment products depicted in Figure 1a to 1k, and/or any one of the filter unit depicted in Figure 5a, Figure 5b and Figure 5c.

[00128] Figure 7a(i) and 7a(ii) show an embodiment of a two-segment
20 aerosol generating product 700 with an aerosol generating segment (first segment) 702 and an integrated support filter segment (second segment) 704. The second segment 704 comprises a core acetate tow portion 706 and an acetate hollow portion 710 having a central hollow portion defining a channel 712, the channel positioned 712 leading from an end of the aerosol generating segment 702 to an air space 714. An air space 714 may be positioned between
25 the acetate tow layer 710 and the core acetate tow portion 706.

[00129] An intermediate layer 716 comprises a first inner layer 718 layered on the core acetate tow portion 706, and a second inner layer 720 layered on the first inner layer 718 and the acetate tow layer 710. In other words, the

second inner layer 720 extends longitudinally across the entire second segment 704.

5 **[00130]** Each of the first inner layer 718 and/or the second inner layer 720 comprises at least one of paper (including coated paper), metal, alloy, reconstituted tobacco sheet, plastic (including PLA and BOPP), polymer and ceramic, etc. is overlay on the core acetate tow layer 706.

10 **[00131]** Above the intermediate layer 716 may be at least one outer layer 722 comprising acetate tow, fiber (including synthetic and natural fiber), cotton, fabric, mesh and/or paper (including coated paper). The outer layer 722 spans the entire second segment 704.

[00132] The entire two-segment aerosol generating product 700 may be wrapped by an outer cover 724. The outer cover 724 may be a layer of paper (including coated paper).

15 **[00133]** As shown in Figure 7a(i), at least one airflow inlet 726 may be formed on the outer cover in a manner such as to allow air flow through the outer layer 722 comprising acetate tow, fiber (including synthetic and natural fiber), cotton, fabric, mesh and/or paper (including coated paper). As an alternative, the embodiment shown in Figure 7a(ii) shows the airflow inlet 726 extending to the air space 714 in a manner such as to allow air flow through the core acetate tow portion 706.

20

[00134] The embodiment shown in Figure 7b(i) is similar to the embodiment of Figure 7a(i), except that the air space 714 is filled with or replaced by a tobacco or charcoal part 728, and the channel 712 may comprises two or more different parts. The embodiment shown in Figure 7b(ii) is similar to the embodiment of Figure 7a(ii), except that the air space 714 is filled with or replaced by a tobacco or charcoal part 728, and the channel 712 may comprises two or more different parts.

25

[00135] Figures 7c(i) and 7c(ii) illustrate embodiments wherein the air space 714 is replaced with or lined with a tube 730. The tube 730 may be formed of

or from one or more of the following metal or metallic alloy, such as but not limited to copper, aluminium, silver, nickel, tin, and/or alloys of the same. The tube 730 may be a hollow or partially hollow tube with different profiles such as cross, star, circle, mesh, forming, multiple circles etc. The tube may be wrapped
5 with paper or reconstituted tobacco sheets.

[00136] As shown in Figure 7c(i), at least one airflow inlet 726 may be formed on the outer cover in a manner such as to allow air flow through the outer layer 722 comprising acetate tow, fiber (including synthetic and natural fiber), cotton, fabric, mesh and/or paper (including coated paper). As an alternative, the
10 embodiment shown in Figure 7c(ii) shows the airflow inlet 726 extending to the tube 730 in a manner such as to allow air flow through the core acetate tow portion 706.

[00137] The embodiment shown in Figure 7d(i) is similar to the embodiment of Figure 7c(i), except that the channel 712 is partially filled with a tobacco or charcoal part 732. The embodiment shown in Figure 7d(ii) is similar to the
15 embodiment of Figure 7c(ii), except that the channel 712 is partially filled with a tobacco or charcoal part 732.

[00138] Figures 7e(i) and 7e(ii) illustrate embodiments wherein the tube 730 extends or spans a length of the entire second segment, and forms an inner layer sandwiched between the acetate tow layer 710 and outer layer 722
20 comprising acetate tow, fiber (including synthetic and natural fiber), cotton, fabric, mesh and/or paper (including coated paper). The tube 730 may be formed of or from one or more of the following metal or metallic alloy, such as but not limited to copper, aluminium, silver, nickel, tin, and/or alloys of the same.
25 The tube 730 may be a hollow or partially hollow tube with different profiles such as cross, star, circle, mesh, forming, multiple circles etc.

[00139] As shown in Figure 7e(i), at least one airflow inlet 726 may be formed on the outer cover in a manner such as to allow air flow through the outer layer 722 comprising acetate tow, fiber (including synthetic and natural fiber), cotton,
30 fabric, mesh and/or paper (including coated paper). As an alternative, the

embodiment shown in Figure 7e(ii) shows the airflow inlet 726 extending to the tube 730 in a manner such as to allow air flow through the core acetate tow portion 706.

5 **[00140]** The embodiment shown in Figure 7f(i) is similar to the embodiment of Figure 7e(i), except that the channel 712 is partially filled with a tobacco or charcoal part 732. The embodiment shown in Figure 7f(ii) is similar to the embodiment of Figure 7e(ii), except that the channel 712 is partially filled with a tobacco or charcoal part 732.

10 **[00141]** Figures 7g(i) and 7g(ii) illustrate embodiments wherein instead of the metal or metallic alloy tube 730, an inner wrapping material 734 is formed from or of one or more metallic layers (e.g. copper, aluminium, nickel, tin or silver) and/or at least one of a reconstituted tobacco sheet, paper (including coated paper), plastic (including PLA and BOPP), polymer ceramic, etc.

15 **[00142]** As shown in Figure 7g(i), at least one airflow inlet 726 may be formed on the outer cover in a manner such as to allow air flow through the outer layer 722 comprising acetate tow, fiber (including synthetic and natural fiber), cotton, fabric, mesh and/or paper (including coated paper). As an alternative, the embodiment shown in Figure 7g(ii) shows the airflow inlet 726 extending to the inner wrapping material 734 in a manner such as to allow air flow through the
20 core acetate tow portion 706.

[00143] The embodiment shown in Figure 7h(i) is similar to the embodiment of Figure 7g(i), except that the channel 712 is partially filled with a tobacco or charcoal part 732. The embodiment shown in Figure 7h(ii) is similar to the embodiment of Figure 7g(ii), except that the channel 712 is partially filled with
25 a tobacco or charcoal part 732.

[00144] Figures 7i(i), 7i(ii) show embodiments similar to Figures 7g(i) and 7g(ii) respectively, wherein in addition to the inner wrapping material 734, there comprises an additional acetate tow layer 736 with or without metal. The

material can include at least one of fiber, strips, sheet, chips, powder or granules.

[00145] Figures 7j(i) and 7j(ii) show embodiments similar to Figures 7h(i) and 7h(ii) respectively, with the additional acetate tow layer 736.

5 **[00146]** Figures 7k(i) and 7k(ii) shows embodiments similar to Figures 7g(i) and 7g(ii) respectively, with an extended air space 714 and a shortened acetate tow portion 706. It is contemplated that the metal tube 730 includes at least one of the following metal copper, aluminum, nickel, tin or silver in various surface configuration including straight, twisting, embossing, crimping forming to shape
10 or alloy or paper or multi-layer including with metal such as aluminum or copper foil, alloy, reconstituted tobacco sheet, paper (including coated paper), plastic (including PLA and BOPP), polymer, ceramic, etc.

[00147] Figures 7l(i) and 7l(ii) are similar to Figures 7k(i) and 7k(ii), except that the metal tube 730 is extended to line part of the channel 712.

15 **[00148]** Figures 7m(i) and 7m(ii) are similar to Figures 7c(i) and 7c(ii), except that the metal tube 730 is extended to line part of the channel 712 and the core acetate tow portion 706.

[00149] Figure 8 (8a to 8h) show various embodiments of a three-segment aerosol generating product 800. The product 800 can incorporate any one of
20 the single-segment aerosol generating products including those depicted in Figures 1a to 1k, and/or any one of the filter unit including those depicted in Figures 5a to 5c.

[00150] Figure 8a(i) and 8a(ii) show an embodiment of a three-segment aerosol generating product 800 with an aerosol generating segment (first
25 segment) 802, a filter segment (second segment) 804, and a support segment 808 (third segment). The second segment 804 comprises a core acetate tow portion 806 positioned at an opposite end from the first segment 802. The support segment 808 may be a support portion positioned between the first segment 802 and the core acetate tow portion 806. The support portion 808

comprises an acetate tow layer 810 having a central hollow portion defining a channel 812. An air space 814 may be positioned between the acetate tow layer 810 and the core acetate tow portion 806.

5 [00151] An intermediate layer 816 comprises a first inner layer 818 layered on the core acetate tow portion 806, and a second inner layer 820 layered on the first inner layer 818 and the empty space 814. The second inner layer 820 extends longitudinally across the entire second segment 804.

10 [00152] Each of the first inner layer 818 and/or the second inner layer 820 comprises at least one of paper (including coated paper), metal, alloy, reconstituted tobacco sheet, plastic (including PLA and BOPP), polymer, ceramic, etc., is overlay on the core acetate tow layer 806.

15 [00153] Above the intermediate layer 816 may be at least one outer layer of 822 comprising acetate tow, fiber (including synthetic and natural fiber), cotton, fabric, mesh and/or paper (including coated paper). The outer layer 822 spans the entire second segment 804.

[00154] The entire three-segment aerosol generating product 800 may be wrapped by an outer cover 824. The outer cover 824 may be a layer of paper (including coated paper).

20 [00155] As shown in Figure 8a(i), at least one airflow inlet 826 may be formed on the outer cover in a manner such as to allow air flow through the outer layer 822 comprising acetate tow, fiber (including synthetic and natural fiber), cotton, fabric, mesh and/or paper (including coated paper). As an alternative, the embodiment shown in Figure 8a(ii) shows the airflow inlet 826 extending to the air space 814 in a manner such as to allow air flow through the core acetate
25 tow portion 806.

[00156] The embodiment shown in Figure 8b(i) is similar to the embodiment of Figure 8a(i), except that the air space 814 is filled with or replaced by a tobacco or charcoal part 828. The embodiment shown in Figure 8b(ii) is similar

to the embodiment of Figure 8a(ii), except that the air space 814 is filled with or replaced by the tobacco or charcoal part 828.

[00157] Figures 8c(i) and 8c(ii) illustrate embodiments wherein the air space 814 is replaced with or lined with a tube 830. The tube 830 may be formed of
5 or from one or more of the following metal or metallic alloy, such as but not limited to copper, aluminium, silver, nickel, tin, and/or alloys of the same. The tube 830 may be a hollow or partially hollow tube with different profiles such as cross, star, circle, mesh, forming, multiple circles etc. The tube may be wrapped with paper (including coated paper) or reconstituted tobacco sheets.

10 **[00158]** As shown in Figure 8c(i), at least one airflow inlet 826 may be formed on the outer cover in a manner such as to allow air flow through the outer layer 822 comprising acetate tow, fiber (including synthetic and natural fiber), cotton, fabric, mesh and/or paper (including coated paper). As an alternative, the embodiment shown in Figure 8c(ii) shows the airflow inlet 826 extending to the
15 tube 830 in a manner such as to allow air flow through the core acetate tow portion 806.

[00159] The embodiment shown in Figure 8d(i) is similar to the embodiment of Figure 8c(i), except that the space 814 is partially or wholly filled with a tobacco or charcoal part 832. The embodiment shown in Figure 8d(ii) is similar
20 to the embodiment of Figure 8c(ii), except that the space 814 is partially or wholly filled with a tobacco or charcoal part 832.

[00160] Figures 8e(i) and 8e(ii) illustrate embodiments wherein the tube 830 extends or spans a length of the entire second segment, and forms an inner wrapping layer sandwiched between the acetate tow layer 810 and outer layer
25 822 comprising acetate tow, fiber (including synthetic and natural fiber), cotton, fabric, mesh and/or paper (including coated paper). The tube 830 may be formed of or from one or more of the following metal or metallic alloy, such as but not limited to copper, aluminium, silver, nickel, tin, and/or alloys of the same. The tube 830 may be a hollow or partially hollow tube with different profiles such
30 as cross, star, circle, mesh, forming, multiple circles etc.

[00161] As shown in Figure 8e(i), at least one airflow inlet 826 may be formed on the outer cover in a manner such as to allow air flow through the outer layer 822 comprising acetate tow, fiber (including synthetic and natural fiber), cotton, fabric, mesh and/or paper (including coated paper). As an alternative, the
5 embodiment shown in Figure 8e(ii) shows the airflow inlet 826 extending to the tube 830 in a manner such as to allow air flow through the core acetate tow portion 806 via the air space 814.

[00162] The embodiment shown in Figure 8f(i) is similar to the embodiment of Figure 8e(i), except that the air space 814 is partially or wholly filled with a
10 tobacco or charcoal part 832. The embodiment shown in Figure 8f(ii) is similar to the embodiment of Figure 8e(ii), except that the air space 814 is partially or wholly filled with a tobacco or charcoal part 832.

[00163] Figures 8g(i) and 8g(ii) illustrate embodiments wherein an inner wrapping material 834 formed from or of one or more metallic layers (e.g.
15 copper, aluminium, nickel, tin or silver) and/or at least one of a reconstituted tobacco sheet, paper (including coated paper), plastic (including PLA and BOPP), polymer, ceramic, etc., may be layered on an inner circumference of the acetate tow layer 810 which defines the channel 812.

[00164] As shown in Figure 8g(i), at least one airflow inlet 826 may be formed
20 on the outer cover in a manner such as to allow air flow through the outer layer 822 comprising acetate tow, fiber (including synthetic and natural fiber), cotton, fabric, mesh and/or paper (including coated paper). As an alternative, the embodiment shown in Figure 8g(ii) shows the airflow inlet 826 extending to the inner wrapping material in a manner such as to allow air flow through the core
25 acetate tow portion 806.

[00165] The embodiment shown in Figure 8h(i) is similar to the embodiment of Figure 8g(i), except that the channel 812 is partially filled with a tobacco or charcoal part 832. The embodiment shown in Figure 8h(ii) is similar to the
30 embodiment of Figure 8g(ii), except that the channel 812 is partially filled with a tobacco or charcoal part 832.

[00166] Figures 8i(i) and 8i(ii) show similar embodiments as Figures 8g(i) and 8g(ii) respectively, the acetate tow layer 810 includes acetate tow with or without metal, and wherein the material includes at least one of fiber, strips, sheet, chips, powder or granules.

5 **[00167]** Figures 8j(i) and 8j(ii) show similar embodiments as Figures 8h(i) and 8h(ii) respectively, the acetate tow layer 810 includes acetate tow with or without metal, and wherein the material includes at least one of fiber, strips, sheet, chips, powder or granules.

10 **[00168]** Figures 8k(i) and 8k(ii) shows embodiments similar to Figures 8c(i) and 8c(ii) respectively, with an extended air space 814 and a shortened acetate tow portion 806. It is contemplated that the metal tube 830 includes at least one of the following metal copper, aluminum, nickel, tin or silver in various surface configuration including straight, twisting, embossing, crimping forming to shape or alloy with paper (including coated paper) or multi-layer including with metal
15 such as aluminum or copper foil, reconstituted tobacco sheet, paper (including coated paper), plastic (including PLA and bOPP), polymer, ceramic, etc.

[00169] Figures 8l(i) and 8l(ii) are similar to Figures 8k(i) and 8k(ii), except that the metal tube 830 is extended to line part of the channel 812.

20 **[00170]** Figures 8m(i) and 8m(ii) show the metal tube 830 extending transversely across one end of the air space 814 to form a cup shape. Figures 8n(i) and 8n(ii) show the metal tube 830 extending transversely across another end of the air space 814 to form a cup shape.

25 **[00171]** Figures 8n(i) and 8n(ii) are similar to Figures 8c(i) and 8c(ii), except that the metal tube 830 is extended to line part of the channel 812 and the core acetate tow portion (806).

[00172] In the described embodiments, the tube material associated with the aerosol generating product can be metal (including copper, aluminum, silver, nickel or tin) or alloy, in hollow tube with different shapes i.e. cross, star, hollow circle, mesh/netting, and formed via multiple circle, twisting, crimping, forming,

embossing profile wrapped with paper or multi-layer, including with metal (including copper, aluminum foil), alloy, reconstituted tobacco sheet, paper (coated paper), plastic (including PLA and BOPP), polymer, ceramic, etc.

5 **[00173]** In the described embodiments, the cross-section of a tube material may be shaped as a circle embossing, circle flat, circle cross, spiral, metal foil spiral straw, metal foil twisting hollow, metal rope hollow, metal cup, shape hollow, etc (see Figure 9). It is appreciable that the tube material may be formed as an intermediate layer to minimize absorption of flavours by filter materials such as acetate tow, and yet providing heat dissipation.

10 **[00174]** It is to be appreciated that variations to the two-segment and three-segment aerosol generating product may be contemplated, wherein the metal/alloy tube constituting the inner wrapping in the filter can be shaped and dimensioned as a metal/alloy cup. The metal/alloy tube and cup constituting the inner wrapping in the filter can have additional profiles of twisted, embossed,
15 crimped, roped, piped, spiraled and other forms to shape. The materials of the metal/alloy tube and cup can be metal, aluminum foil, aluminum alloy, metal alloy, etc. The metal/alloy tube and cup can be made by embossing, crimping, compressed extrusion, forming, die casting, extrusion, flow wrapping and any other methods of manufacture of the metal/alloy tube and cup.

20 **[00175]** In the described embodiments, it is contemplated that the heating device can include a metal cup structure (such as the cylinder or cup structure 207) to hold the aerosol generating product. It is also contemplated that one or more ventilation device(s), e.g. a fan can be added into the device to provide cooling.

25 **[00176]** In the described embodiments, it is contemplated that the at least a layer of the single segment and/or multi-segment aerosol generating product may comprise two surface, with an outer surface coated with paper and an inner surface coated with metal (including copper, aluminium, silver, nickel, or tin), or metallic alloy foil laminate, reconstituted tobacco sheet, paper (including coated

paper), plastic (including PLA and BOPP), polymer, ceramic, etc.), before being formed onto a desired shape, such as tubular shape.

[00177] It is to be appreciated by the person skilled in the art that variations and combinations of features described above, not being alternatives or
5 substitutes, may be combined to form yet further embodiments falling within the intended scope of the invention.

CLAIMS

1. A heating device (200) for heating an aerosol generating substrate below a combustion temperature of the aerosol generating substrate, the heating device
5 comprises

a suction portion (202) having an opening for a user to consume aerosol generated by the aerosol generating substrate;

a substrate holder (204) for receiving an aerosol generating substrate;

a heating element (206) shaped and dimensioned to heat the aerosol
10 generating substrate (205) to produce aerosol; and

an aerosol delivery channel (208) arranged to receive aerosol generated from heating the aerosol generating substrate (205) and to direct the aerosol towards the suction portion (202) when a user apply a suction force via the suction portion (202);

15 wherein the suction portion (202) comprises a heat dissipation element (240) and is shaped to be slidably received in the heating device.

2. The heating device (200) of claim 1, comprising a through-hole (270) spanning across the device (200), the through-hole (270) forming the aerosol delivery channel (208) and substrate holder (204), wherein a first end (270a) of
20 the through-hole (270) is dimensioned to slidably receive the suction portion (202).

3. The heating device (200) of claim 2, wherein the heating element (206) comprises a cylindrical hollow portion surrounding a part of the through-hole (270), such that there comprises a first cross-sectional side (206a) and second
25 cross-sectional side (206b) configured to heat the aerosol generating substrate (205) when the aerosol generating substrate (205) is positioned therebetween.

4. The heating device (200) of claim 3, wherein the suction portion (202) is shaped and dimensioned to urge the aerosol generating substrate (205) toward

a position between the first cross-sectional side (206a) and the second cross-sectional side (206b).

5 5. The heating device (200) of any one of the preceding claims, wherein the through-hole (270) is dimensioned to receive a filter unit (500), wherein the filter unit (500) is positioned in operation such that heated aerosol is directed pass the filter unit (500) before reaching the suction portion (202).

10 6. The heating device (200) of claim 5, wherein the through-hole (270) comprises a second end (270b) for at least one of the aerosol generating substrate (205) and filter unit (212) to be urged out of the through-hole (270) after consumption.

15 7. The heating device (200) of claim 1, wherein the suction portion (202) and substrate holder are integrated in the form of a jig (600) having an elongate structure, the elongate structure comprises a plurality of compartments (604); wherein a first compartment (610) of the plurality of compartments is shaped and dimensioned to receive the aerosol generating substrate (205), and a second compartment (612) of the plurality compartments (604) is shaped and dimensioned to receive a filter unit (500).

20 8. The heating device (200) of claim 7, wherein the jig (600) further comprises an end portion (608) positioned distally with respect to the suction portion (602), wherein either the first compartment (610) or the end portion (608) comprises a C-shaped opening (628) for easy removal of residue of the aerosol generating substrate.

25 9. The heating device (200) of any one of claims 2 to 6, further comprises an air-seal (274) positioned on at least one of an outer periphery of the suction portion (202) and an inner surface of the through-hole (270).

10. An aerosol generating product (100) for use with the heating device of any one of claims 1 to 9, the aerosol generating product (100) comprising a core layer (102) having an aerosol generating substrate (104), wherein the aerosol generating substrate (104) comprises at least one of the following: a

reconstituted tobacco sheet, a cast leaf tobacco (CLT) sheet, tobacco powder, a cut tobacco roll, an acetate tow, a natural fiber, a natural leaf, a cellulose fiber, tobacco pallets, aluminum, copper, metallic alloy, acetate tow, paper, fiber, and ceramic.

5 11. The aerosol generating product (100) of claim 10, further comprises an outer layer (106) in the form of a cover or wrapper to at least partially surround the core layer (102) to provide structural integrity thereof, the outer layer (106) comprises at least one of the following: acetate tow, and/or fibre, natural fibre (including cotton), and/or cellulose fibre paper (including coated paper).

10

12. The aerosol generating product (100) of claim 10 or 11, further comprising an intermediate layer (108) between the core layer (102) and the outer layer (106), the intermediate layer (108) comprises a single layer with aluminium foil and/or paper, a multi-layer comprising an aluminium foil and/or paper, a reconstituted tobacco sheet, acetate tow, paper, fibre (including natural fibre) and ceramic.

15

13. The aerosol generating product (100) of any one of claims 10 to 12, wherein the core layer (102) comprises a hollow portion (110) arranged adjacent to the aerosol generating substrate (104).

20

14. The aerosol generating product (100) of claim 13, further comprises another intermediate layer (112) extending across the aerosol generating substrate (104) but not the hollow portion (110).

25 15. A two-segment product (700) comprising an aerosol generating segment (702) and an integrated support-filter segment (704) adjoining the aerosol generating segment (702), the integrated support-filter segment (704) comprises a core acetate tow portion (706) and an acetate tow hollow layer (710) having a central hollow portion defining a channel (712), the channel positioned (712) leading from an end of the aerosol generating segment (702) to an air space (714); wherein the air space (714) is lined with a tube (730).

30

formed of or from at least one of the following: - copper, aluminum, nickel, tin, silver, metal alloy, paper, multi-layer including with metal such as aluminum or copper foil, alloy, reconstituted tobacco sheet, paper (including coated paper) or ceramic.

5 16. The two-segment product (700) of claim 15, wherein the tube (730) extends across the air space (714), the channel (712) and the core acetate tow portion (706).

10 17. The two-segment product (700) of claim 16, wherein the tube (730) extension across the channel (712) is longer than the extension across the core acetate tow portion (706).

15 18. The two-segment product (700) of any one of claim 15 to claim 17, further comprising an outer layer (722), the outer layer (722) comprising acetate tow and wrapped by an outer cover (724); and at least one airflow inlet (726) formed on an outer cover (724) in a manner such as to allow air flow through the outer layer (722) and/or towards the tube (730) and enter the air space (714).

20 19. A three-segment product (800) comprising an aerosol generating segment (802), a support segment (808), and a filter segment (804); the filter segment (804) comprises a core acetate tow portion (806) positioned at an opposite end from the aerosol generating segment (802) and the support segment (808) positioned between the aerosol generating segment (802) and the core acetate tow portion (806), the support segment (808) comprises an acetate tow layer (810) having a central hollow portion defining a channel (812); and an air space (814) positioned between the acetate tow layer (810) and the core acetate tow portion (806); wherein the air space (814) is lined with a tube (830) formed of
25 or from at least one of the following:- copper, aluminum, nickel, tin, silver, metal alloy, paper, multi-layer including with metal such as aluminum or copper foil, alloy, reconstituted tobacco sheet, paper (including coated paper), or ceramic.

20. The three-segment product (800) of claim 19, wherein the tube (830) extends across the air space (814) and the core acetate tow portion (806).

21. The three-segment product (800) of claim 19 or 20, further comprising an outer layer (822), the outer layer (822) comprising acetate tow and wrapped by an outer cover (824); and at least one airflow inlet (826) formed on an outer cover (824) in a manner such as to allow air flow through the outer layer (822) and/or towards the tube (830) and enter the air space (814).
- 5

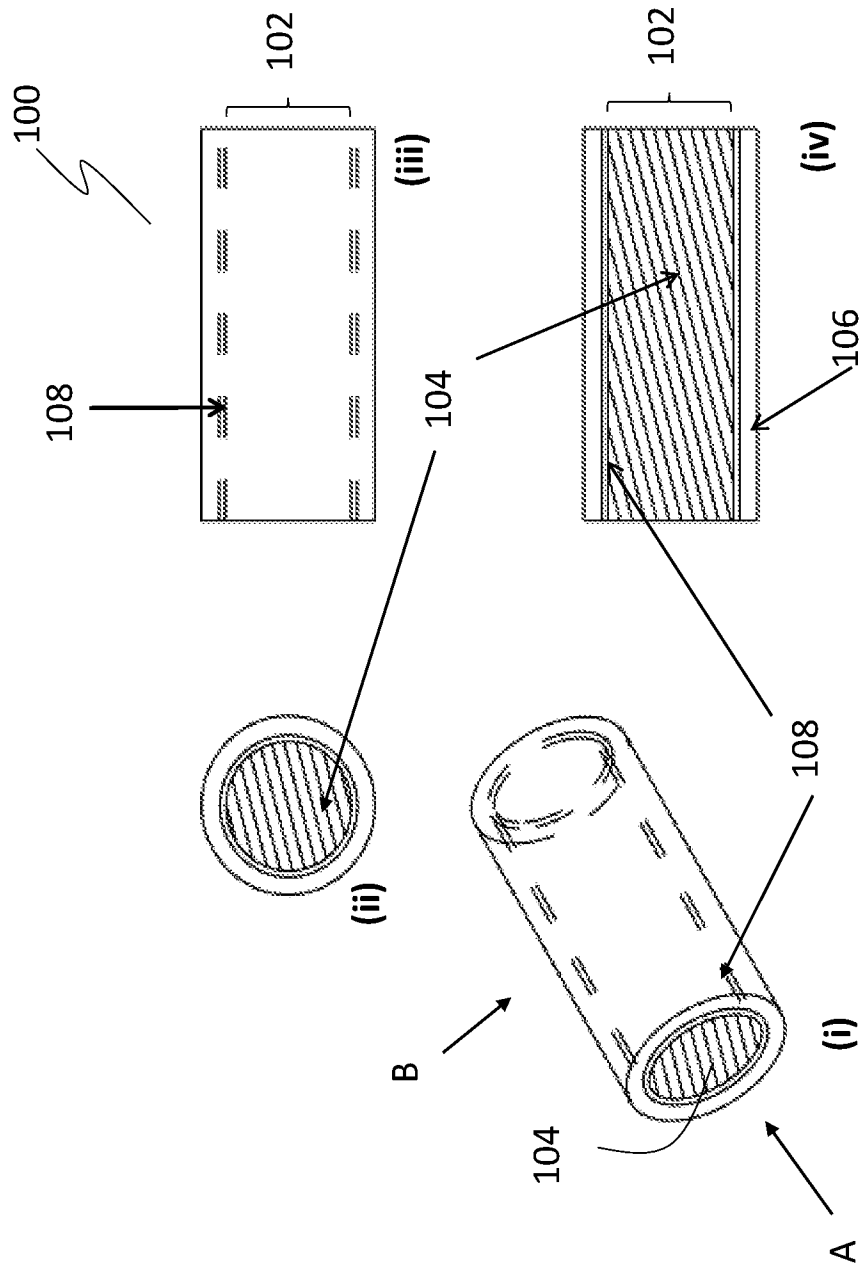

Figure 1a

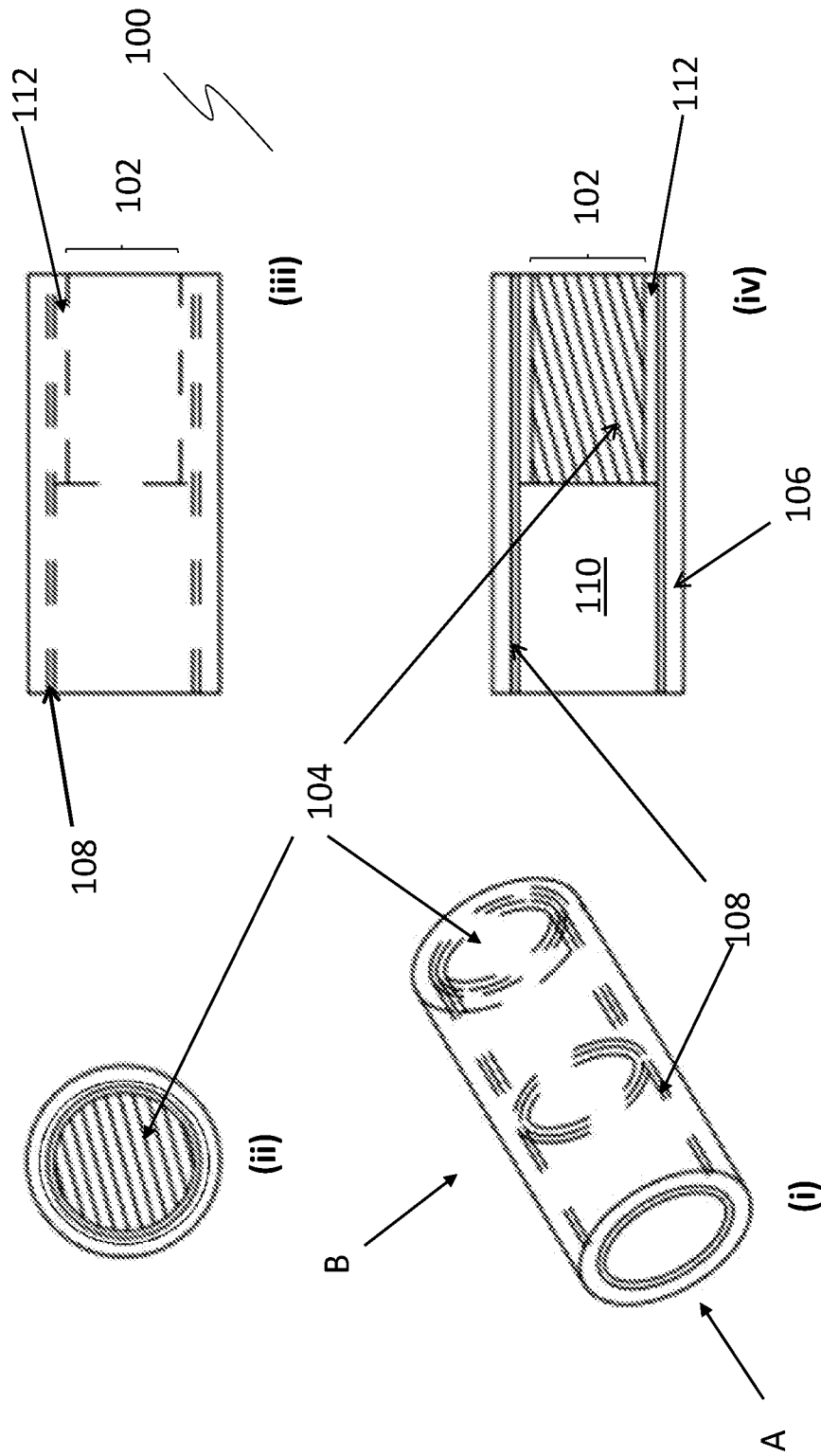

Figure 1b

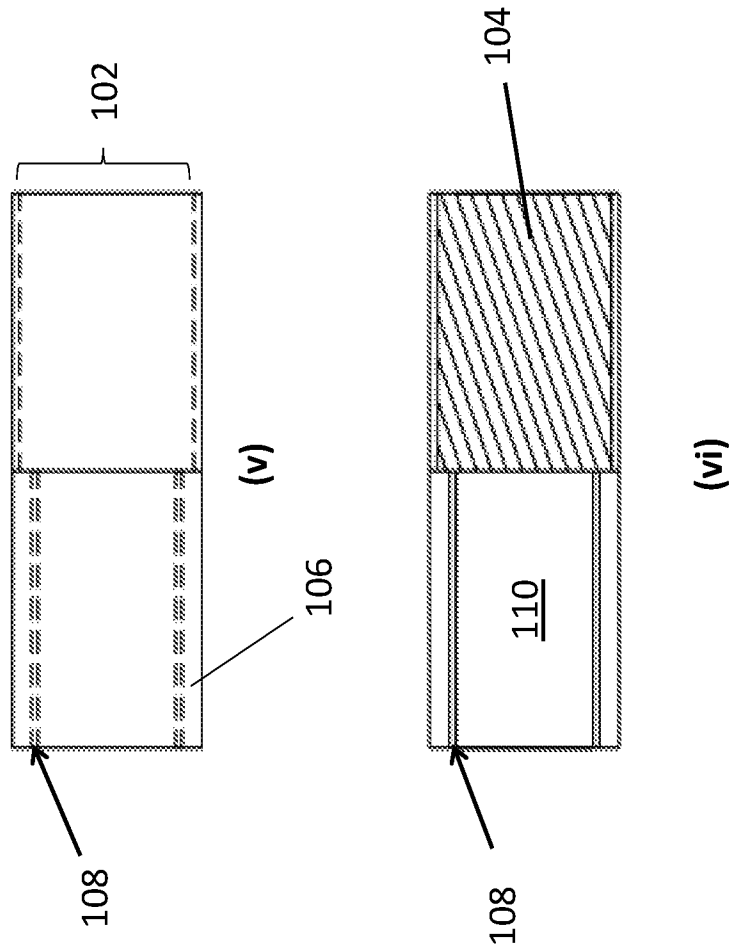

Figure 1b (continued)

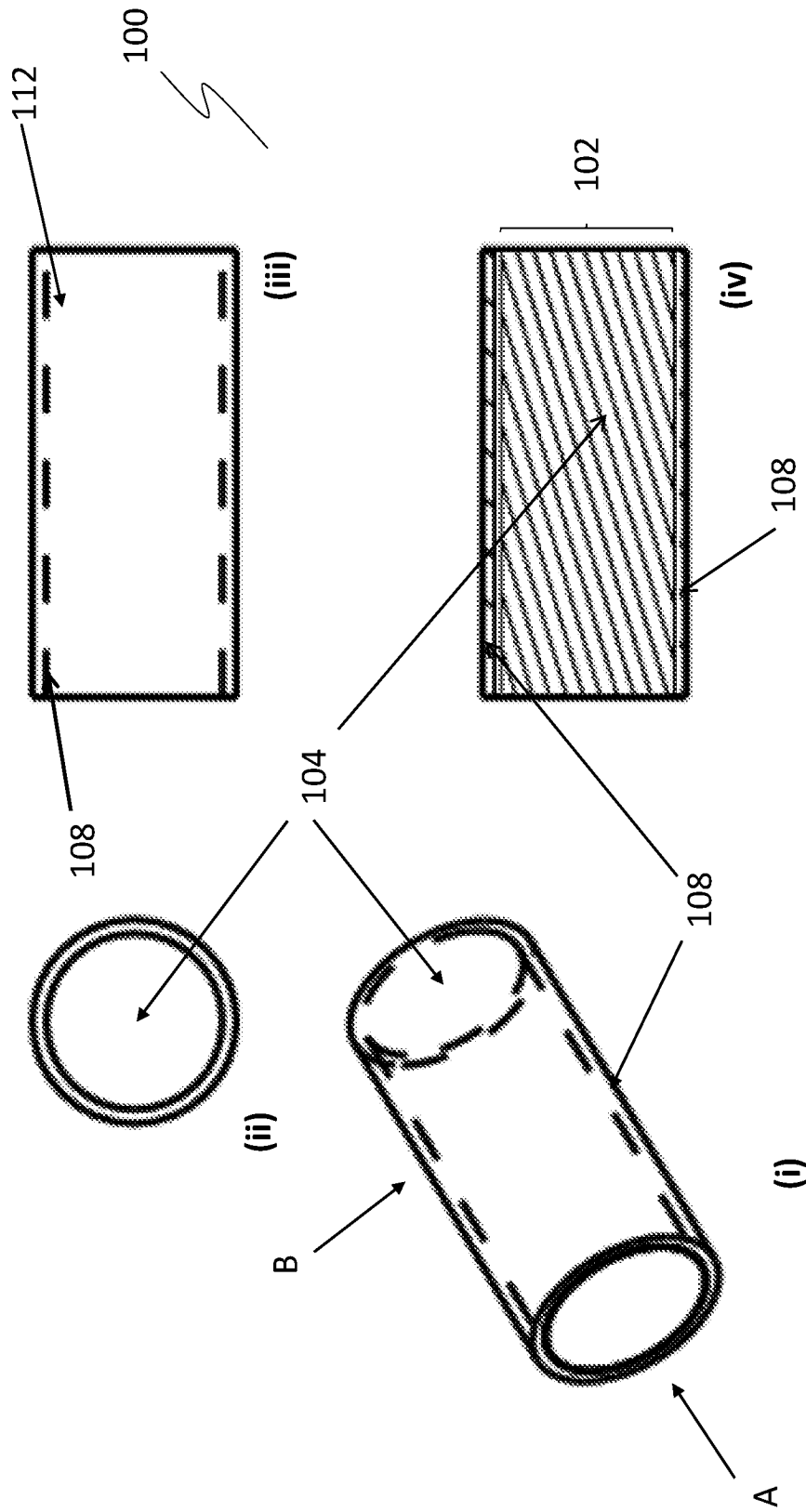

Figure 1c

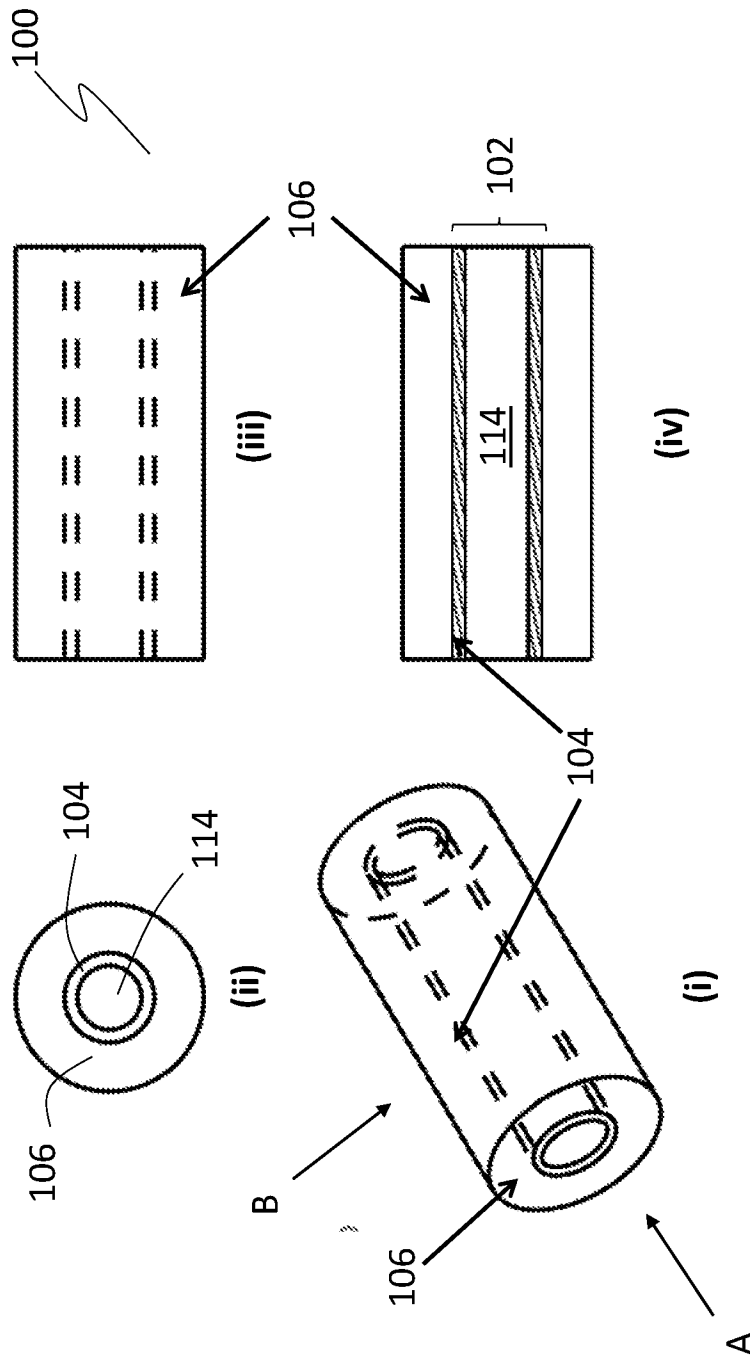

Figure 1d

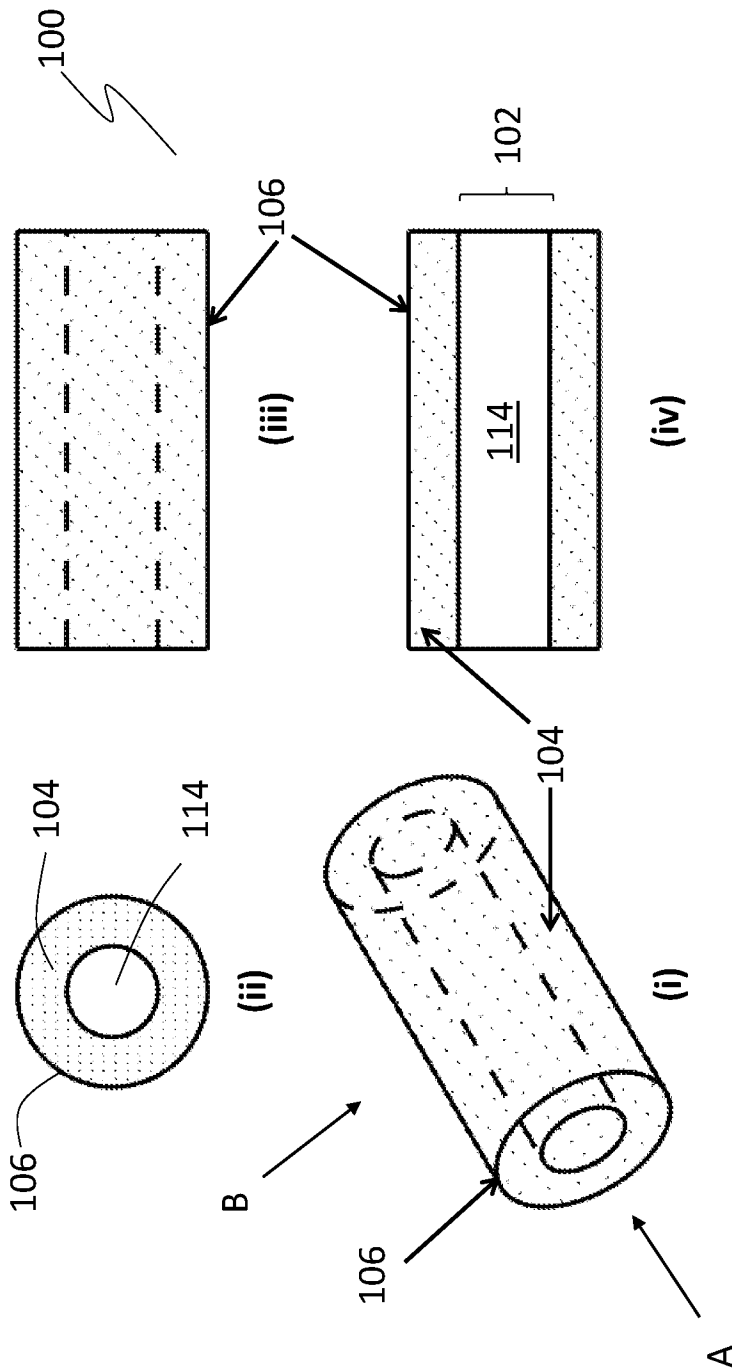

Figure 1e

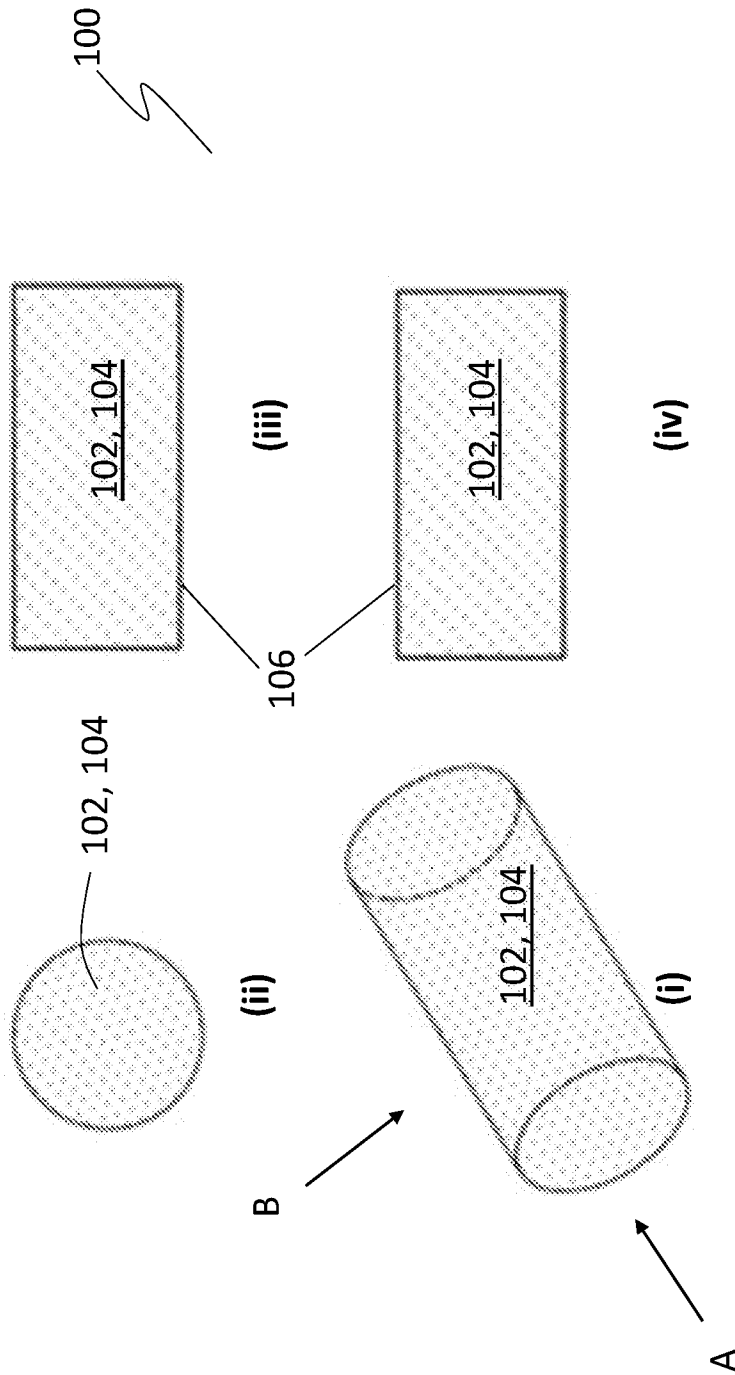

Figure 1f

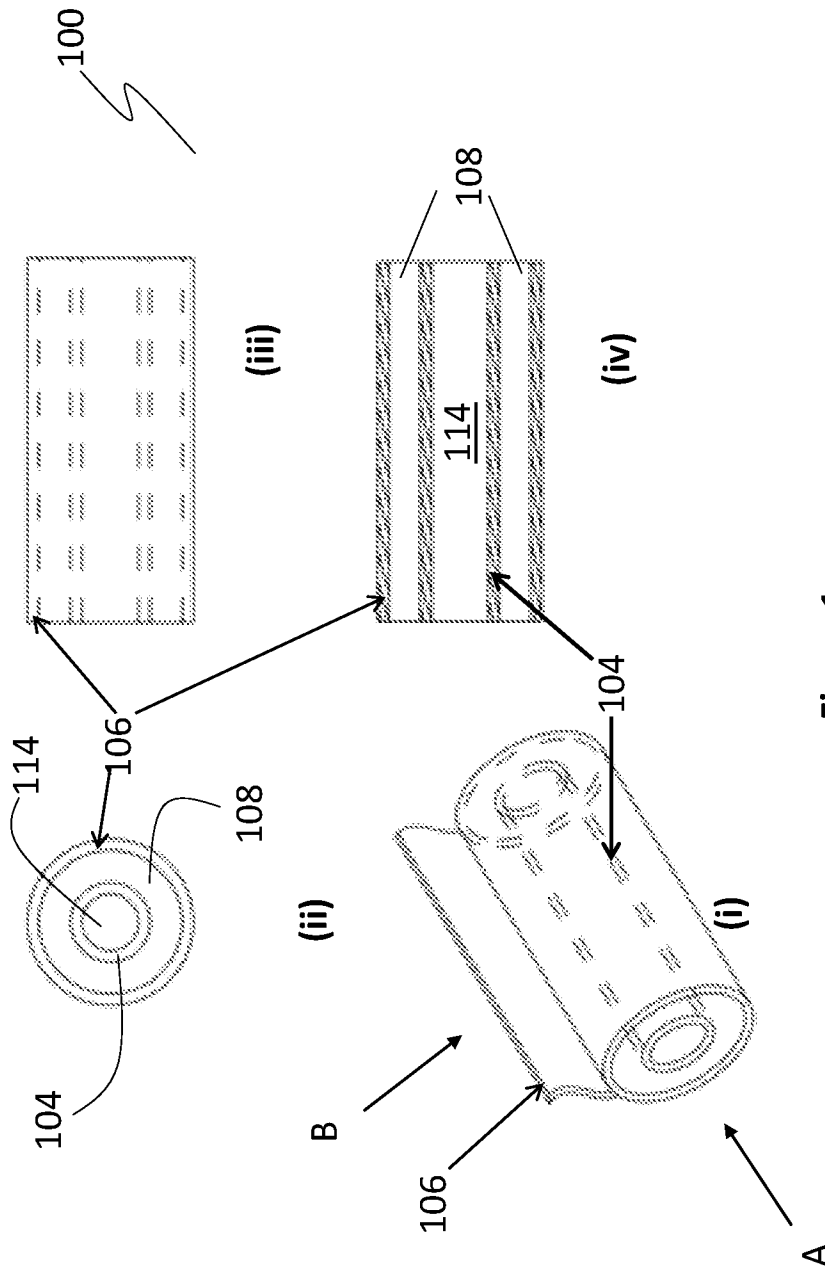

Figure 1g

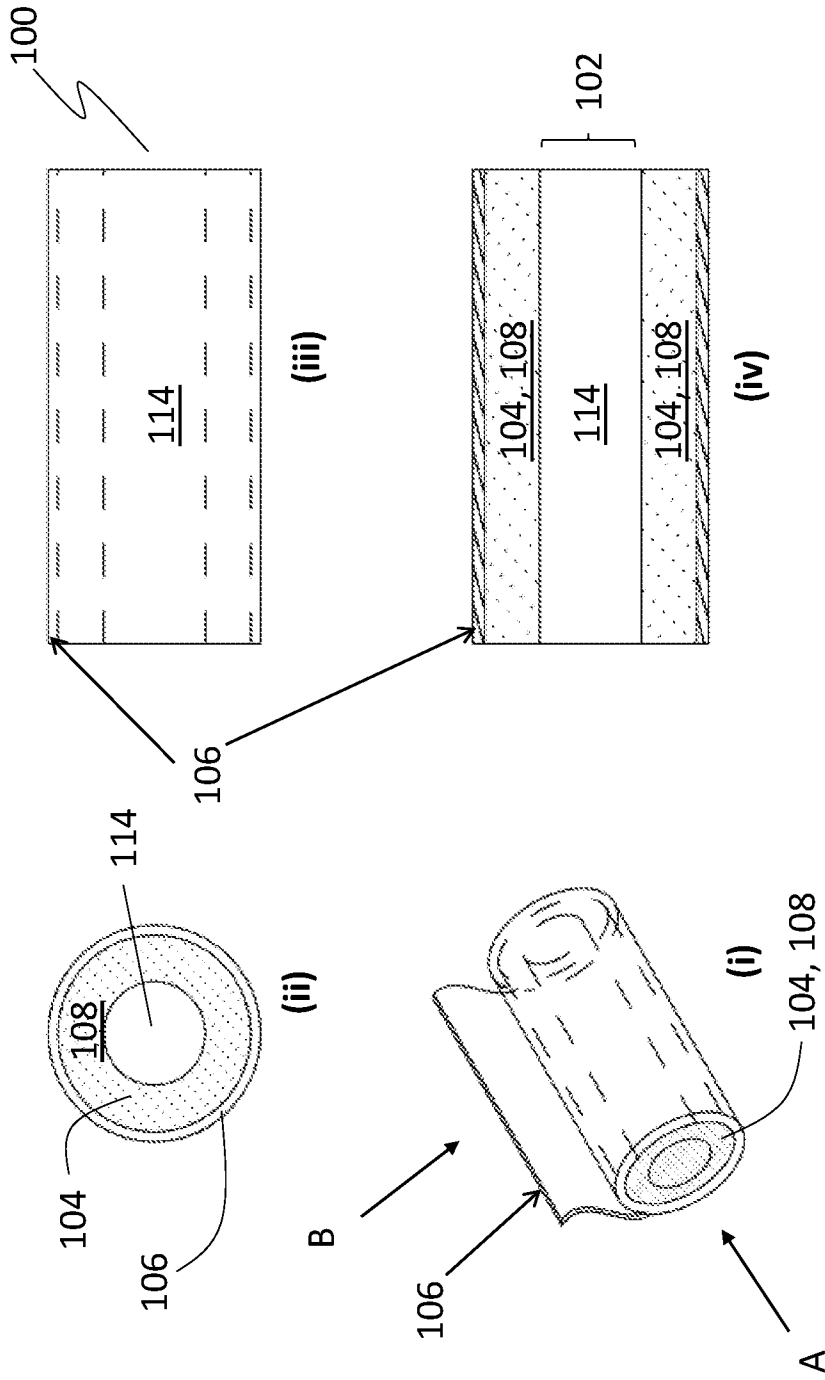

Figure 1h

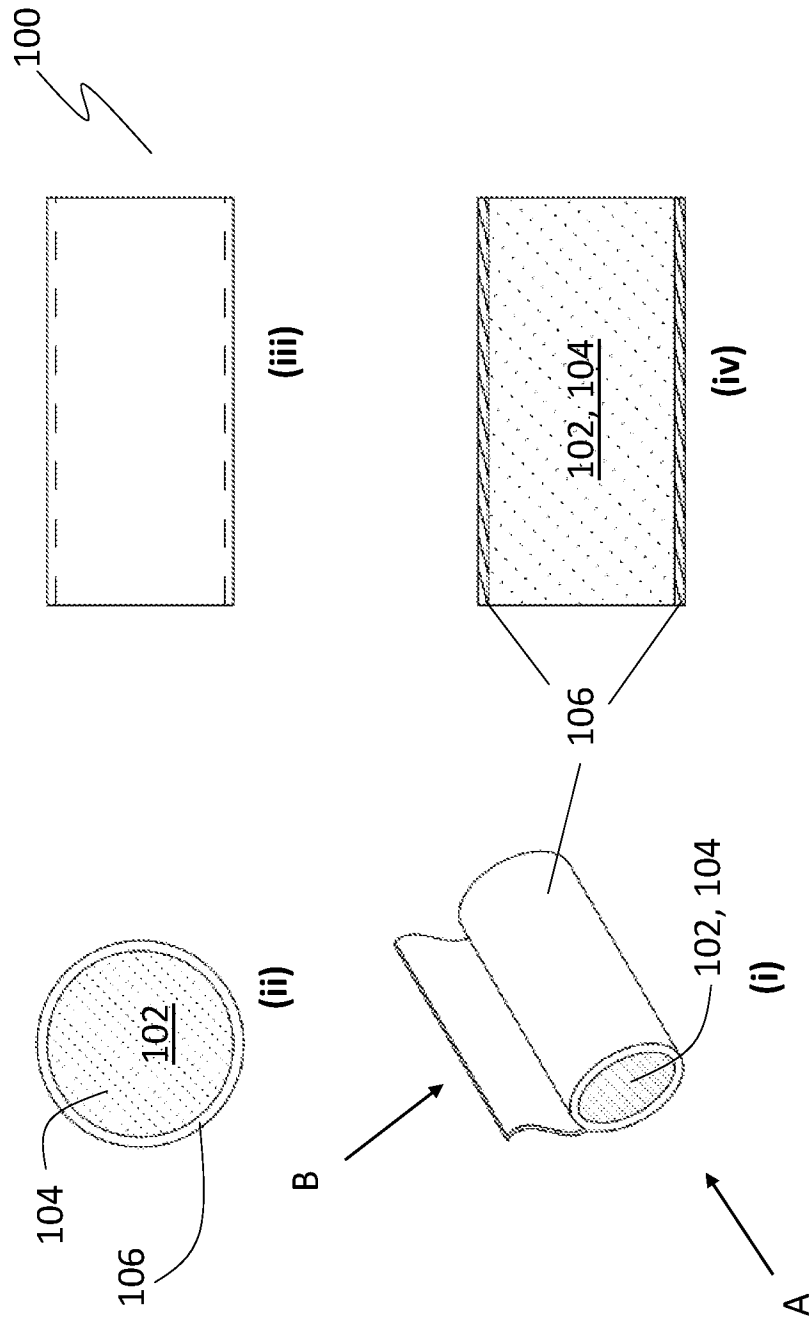

Figure 1i

11/53

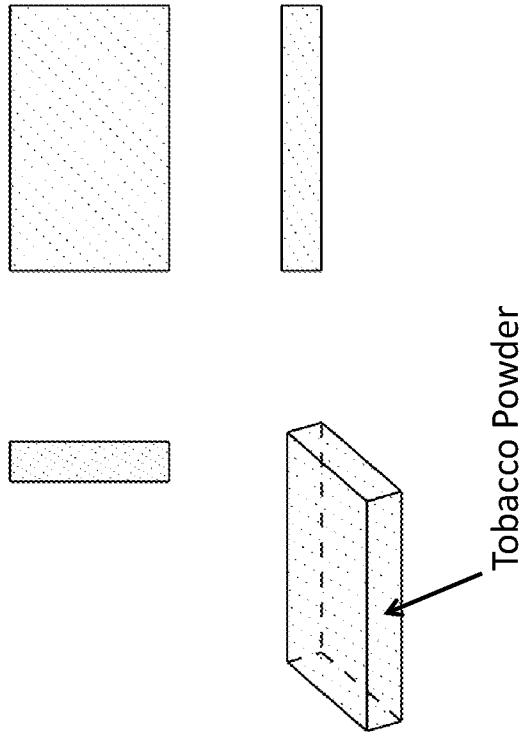

Figure 1k

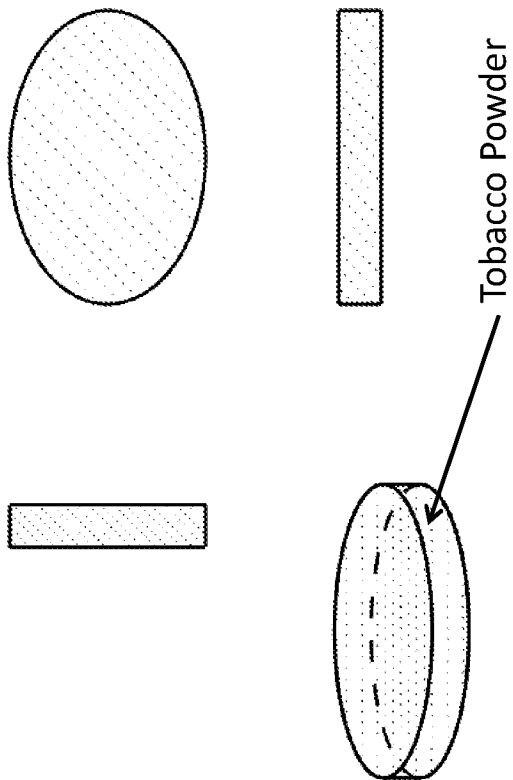

Figure 1j

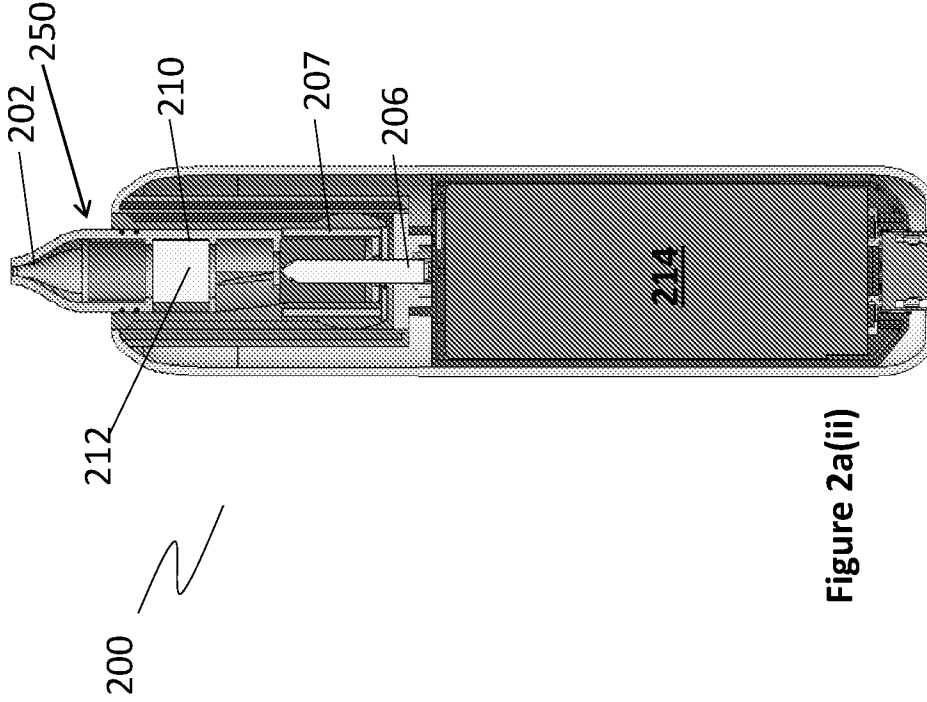

Figure 2a(ii)

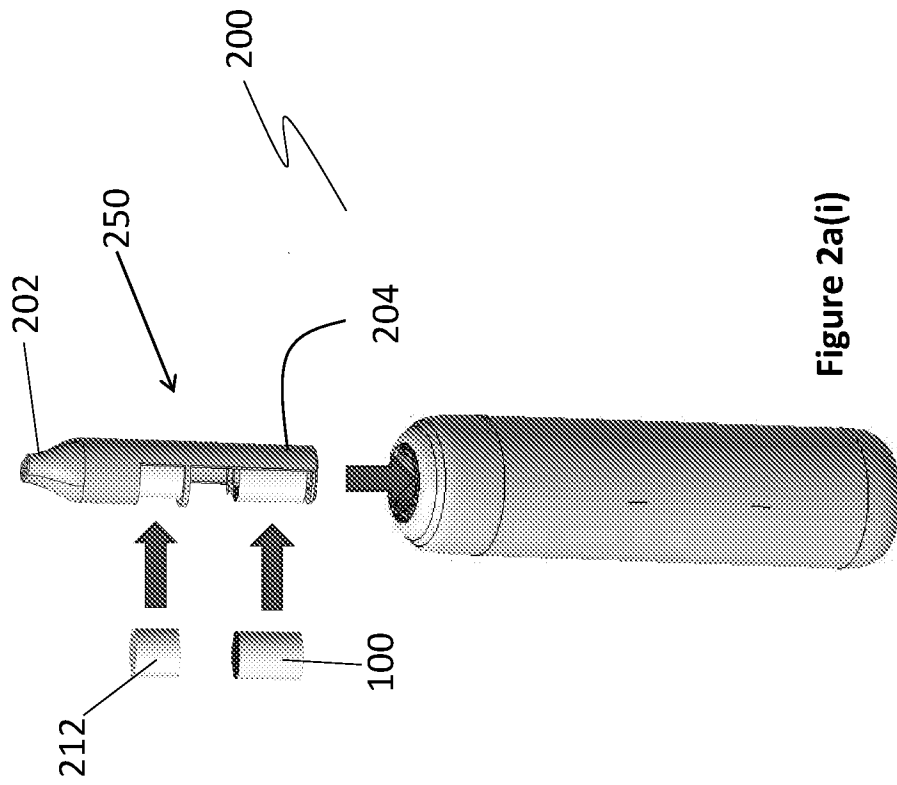

Figure 2a(i)

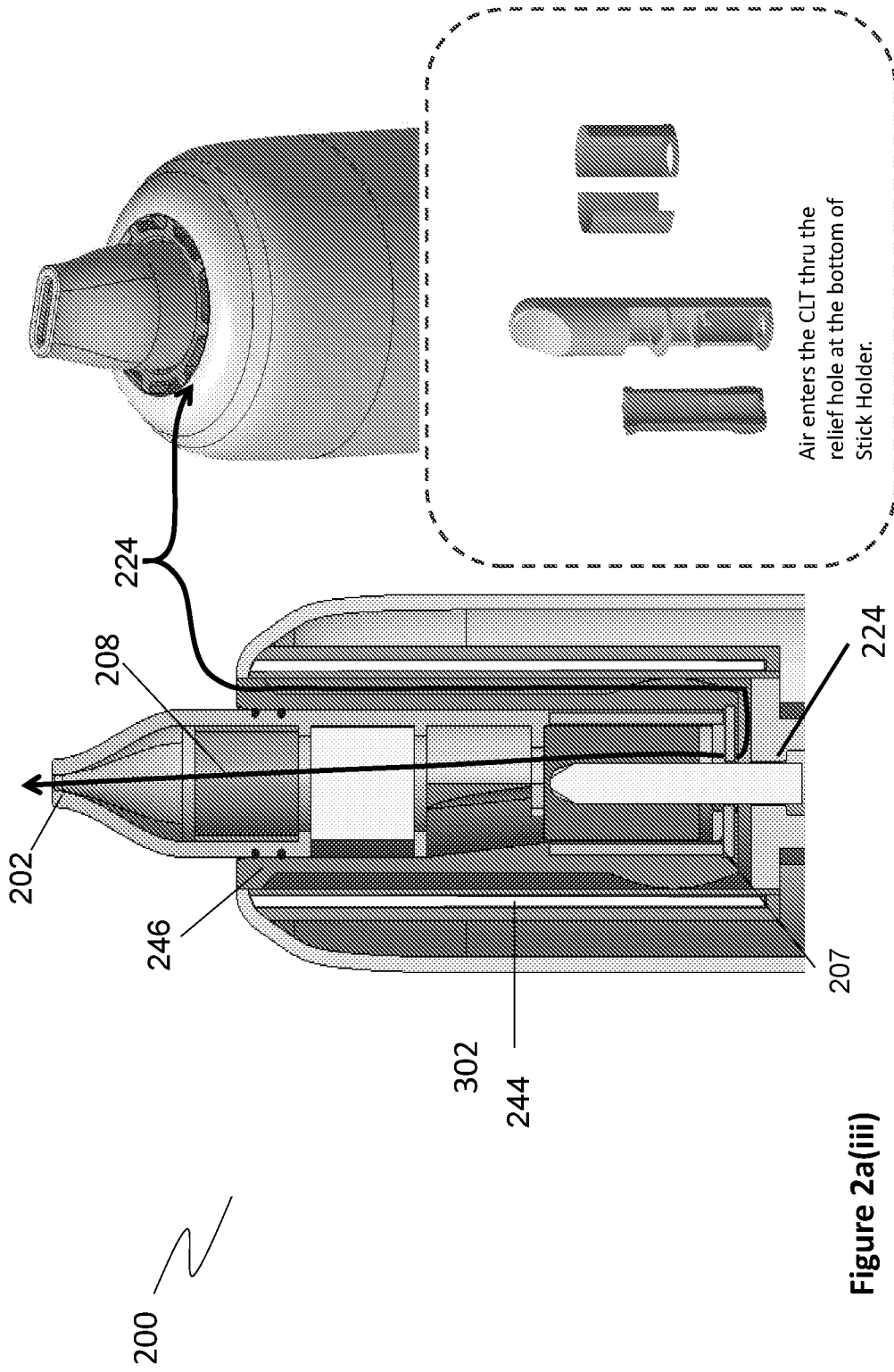

Figure 2a(iii)

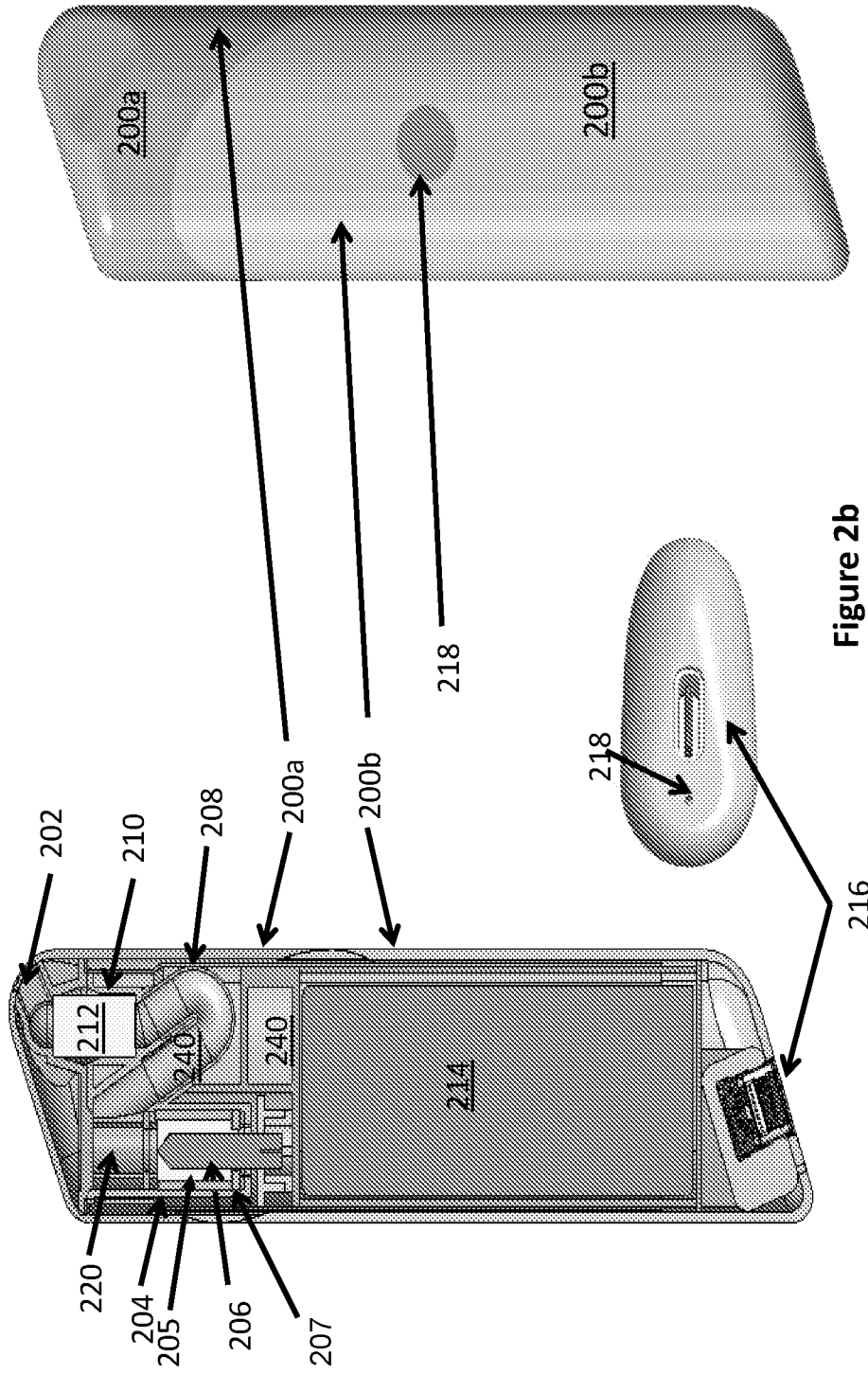

Figure 2b

15/53

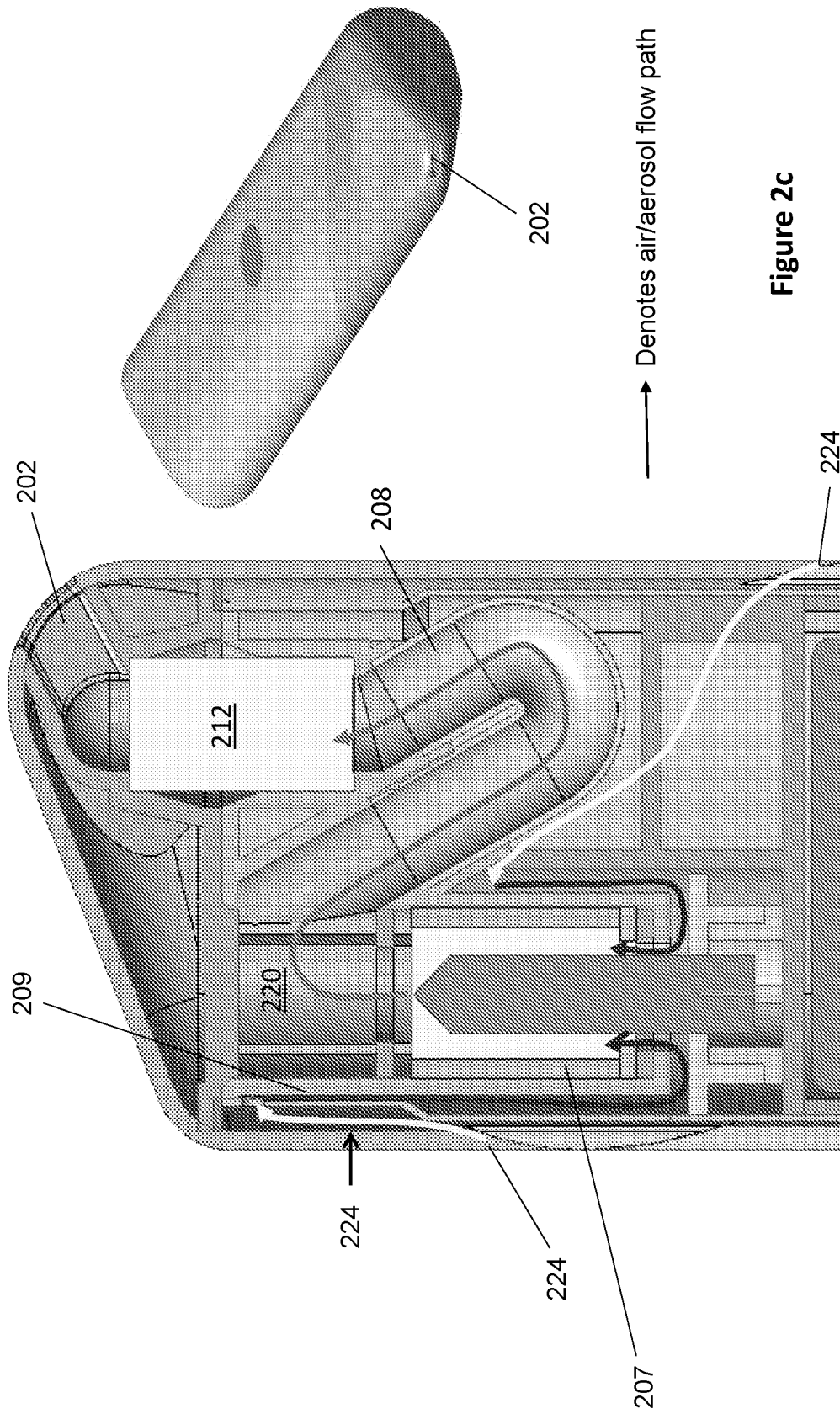

Figure 2c

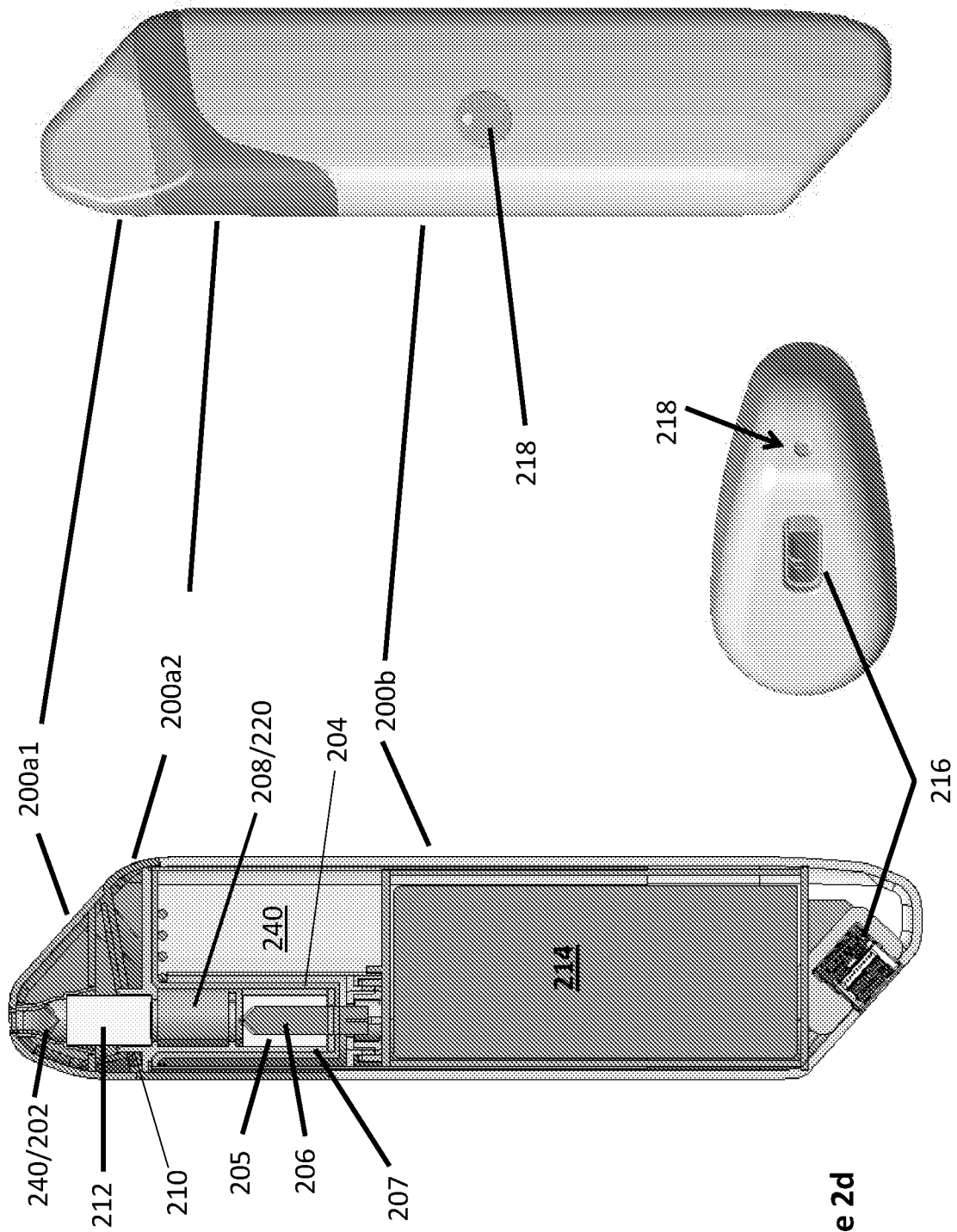

Figure 2d

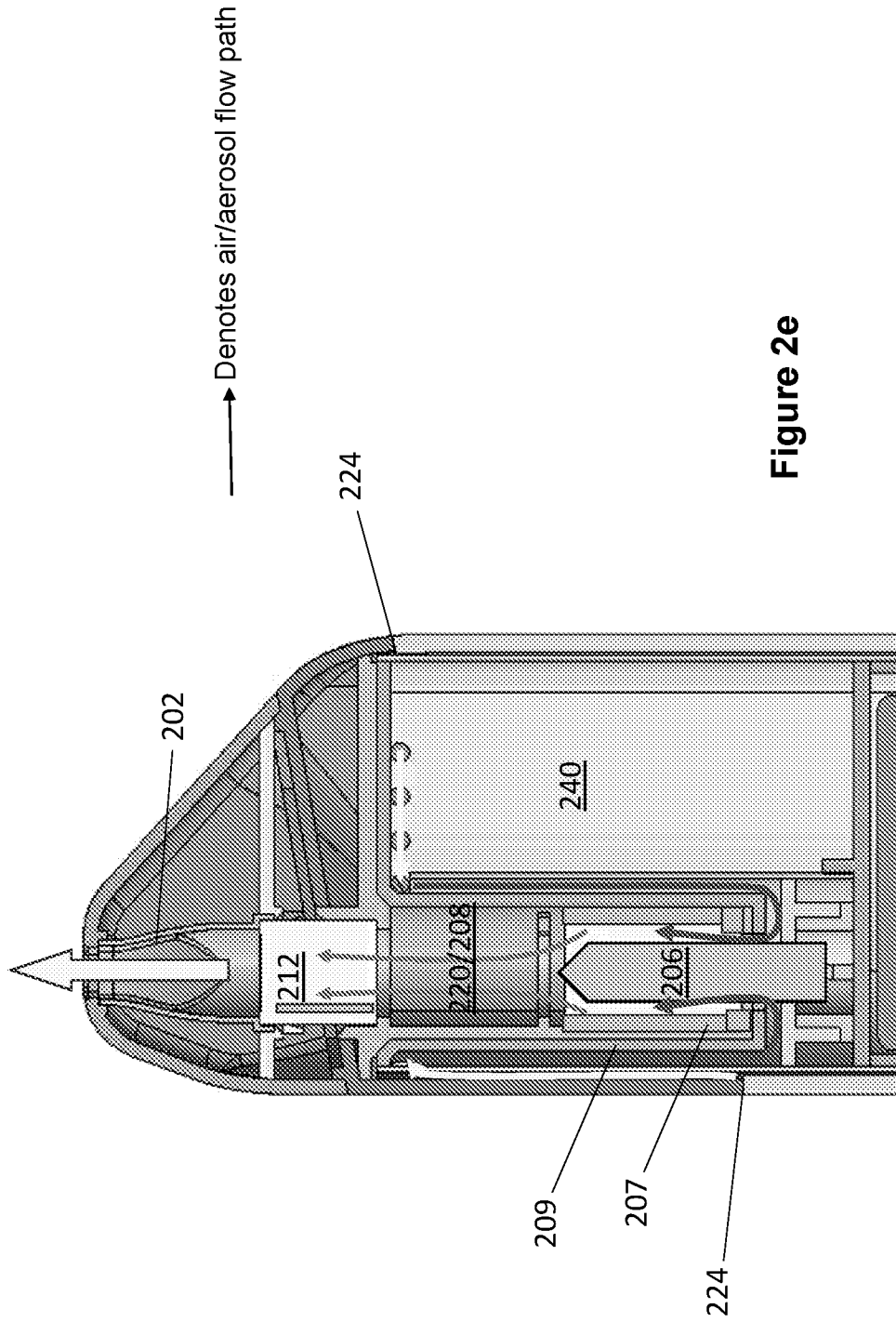

Figure 2e

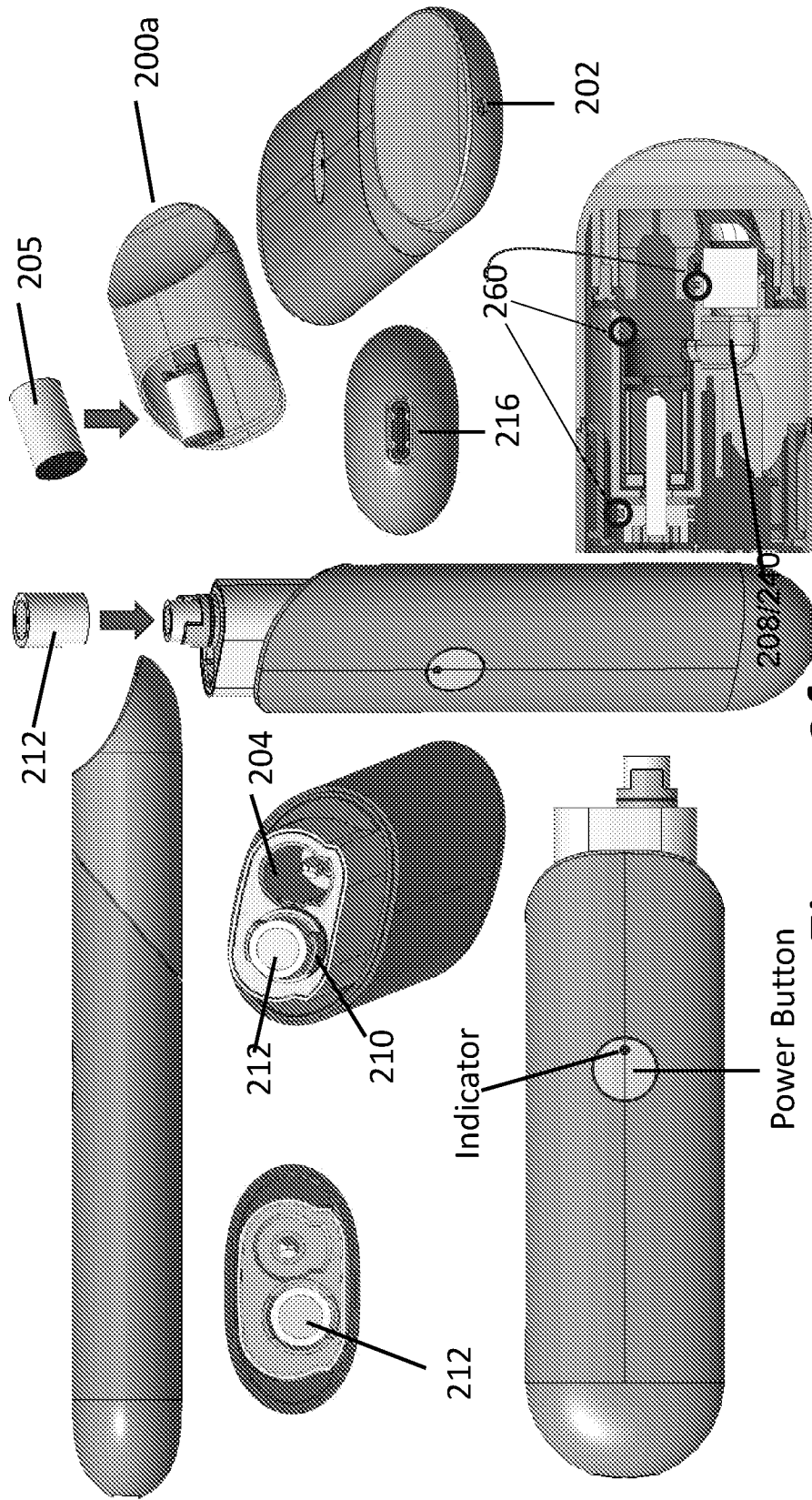

Figure 2f

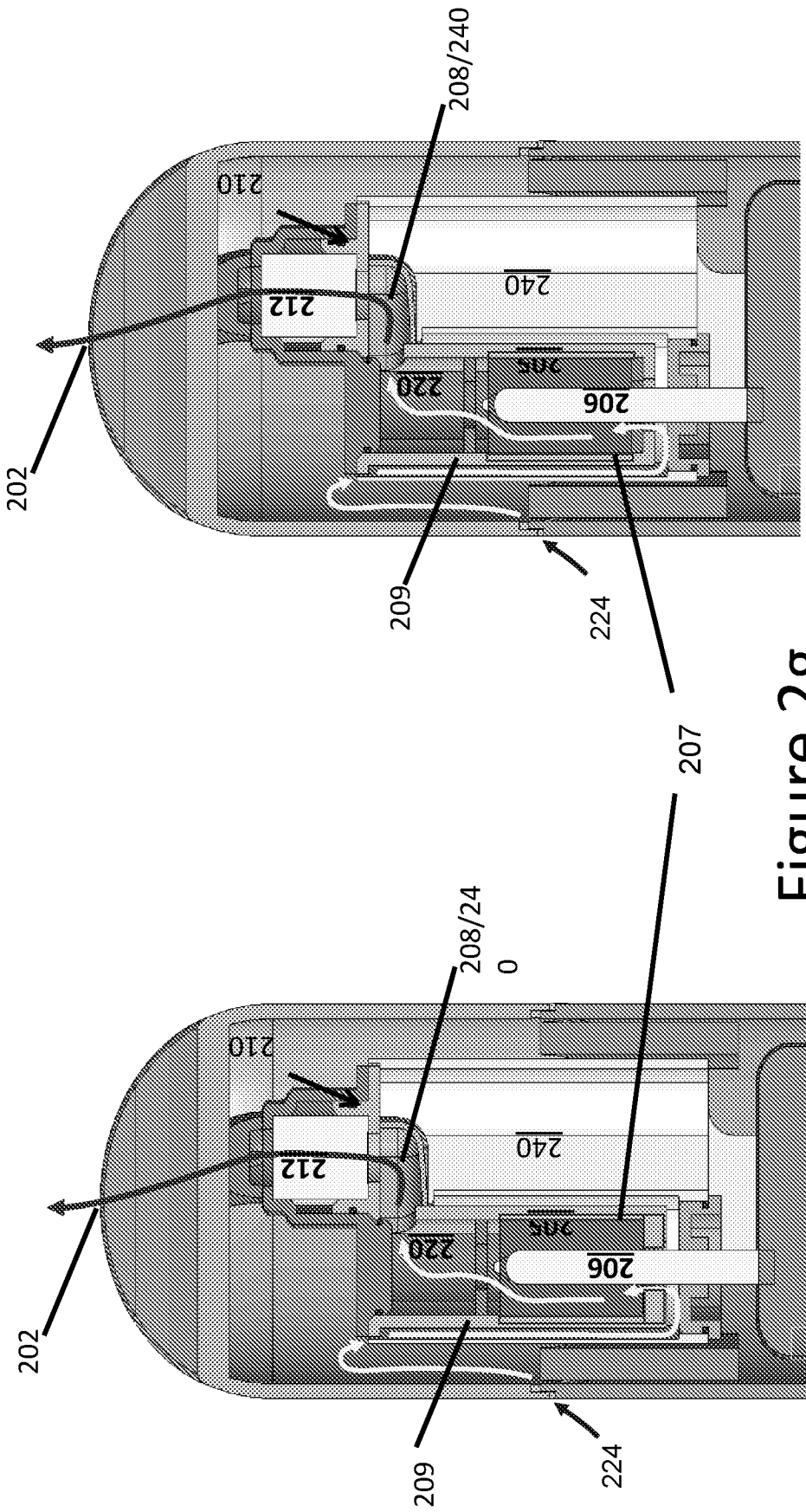

Figure 2g

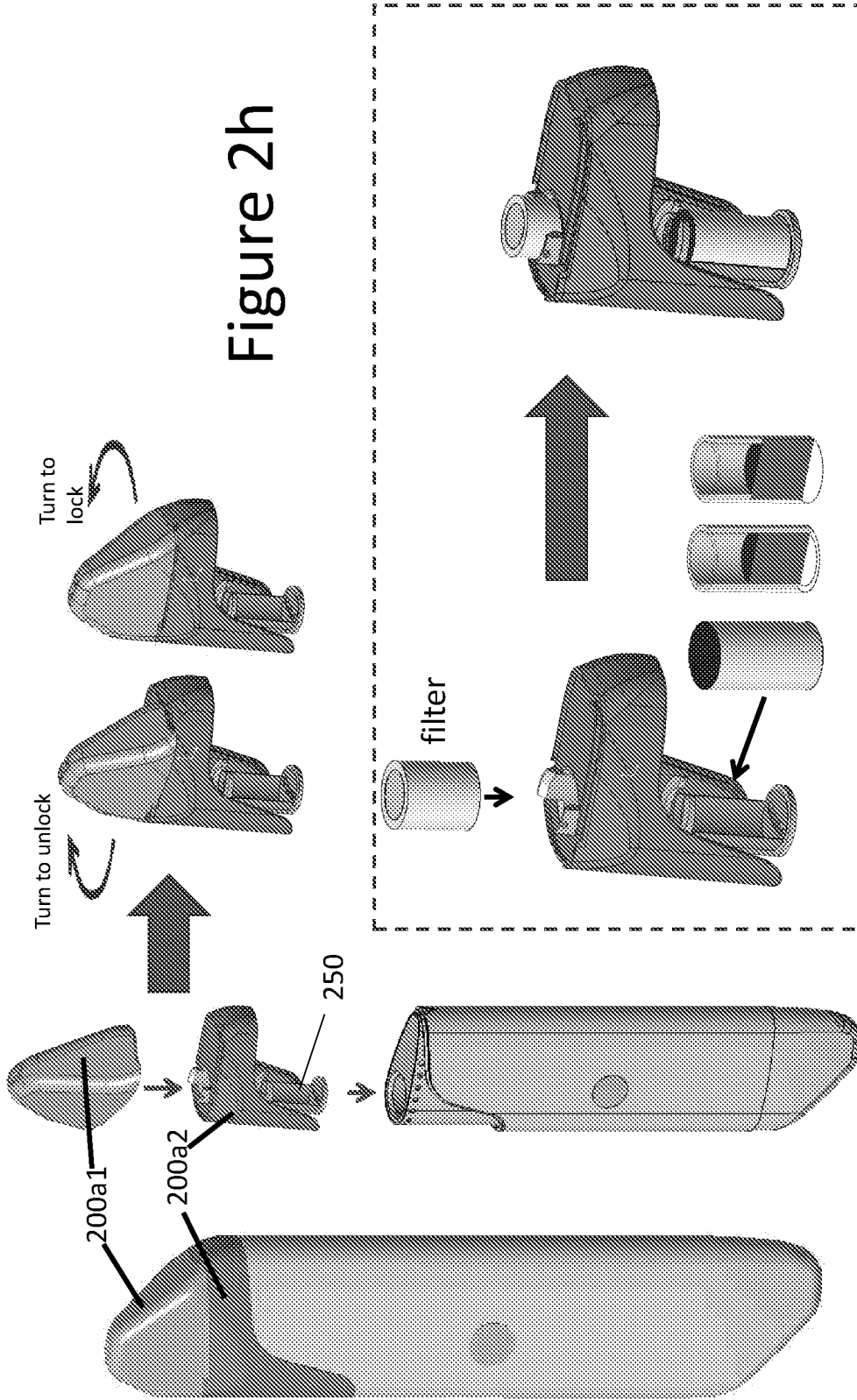
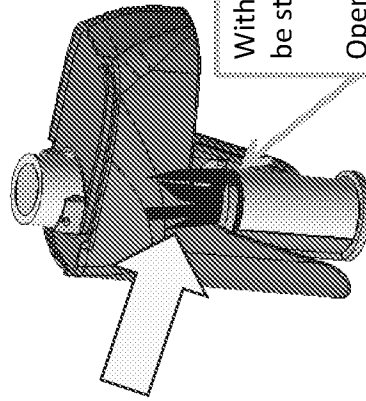
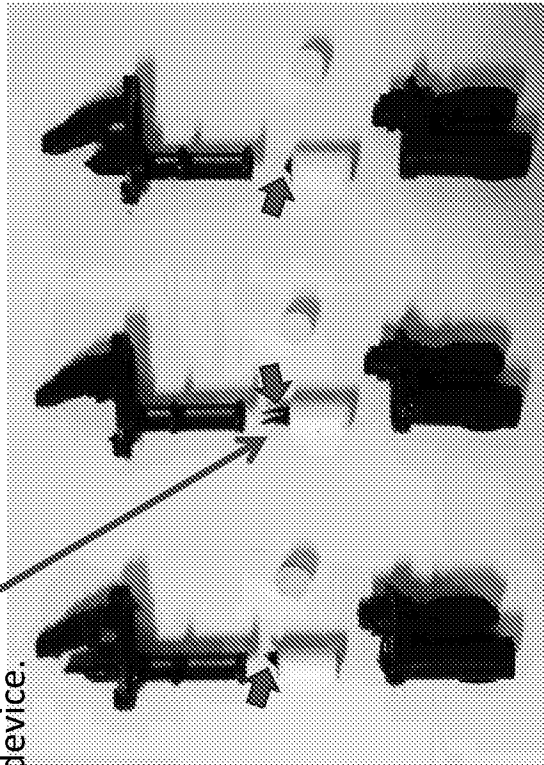

Figure 2h

Figure 2i

Excessive tobacco pushed out from the CLT when inserted into the device.



Without opening, the CLT may be stuck

Openings/gaps facilitates excess material to fall off easily as it will be very hot for user to touch after smoking.

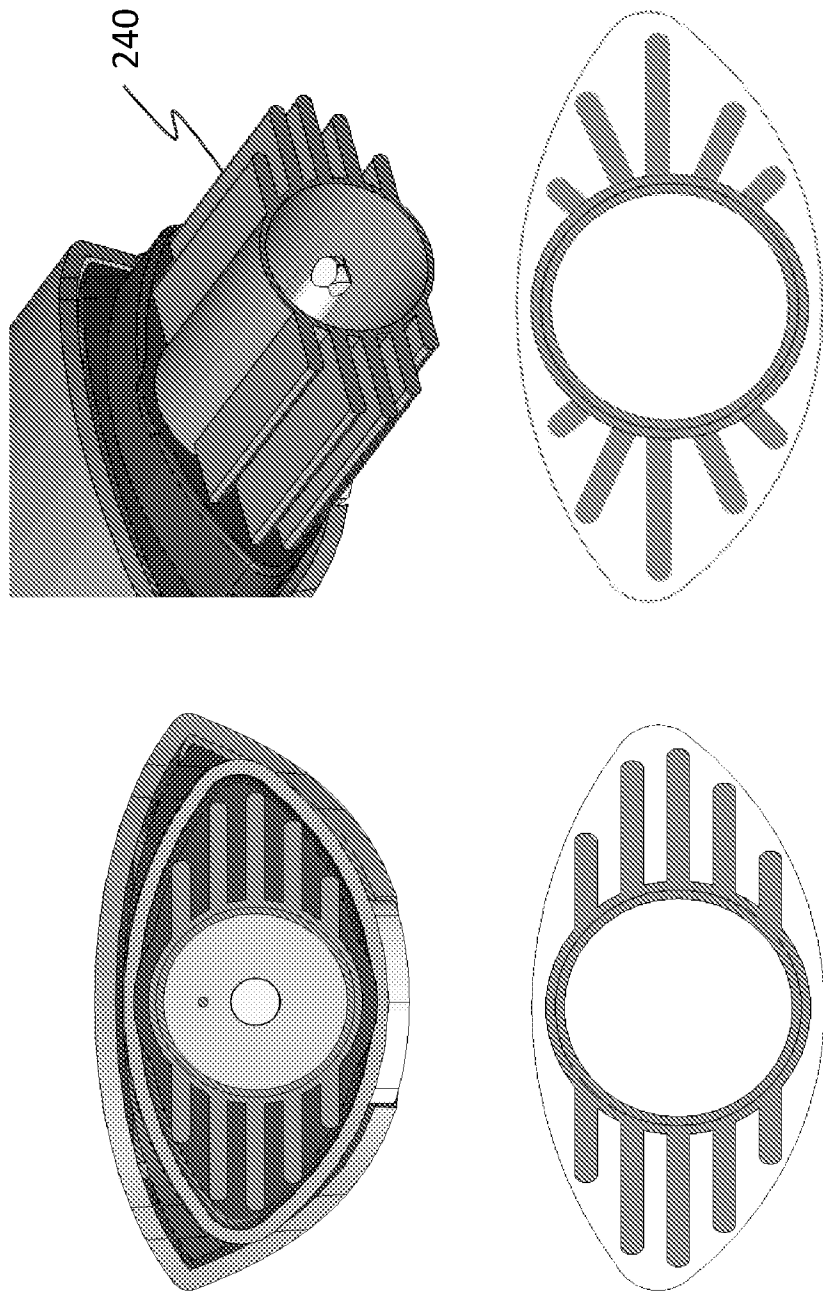

Figure 2j

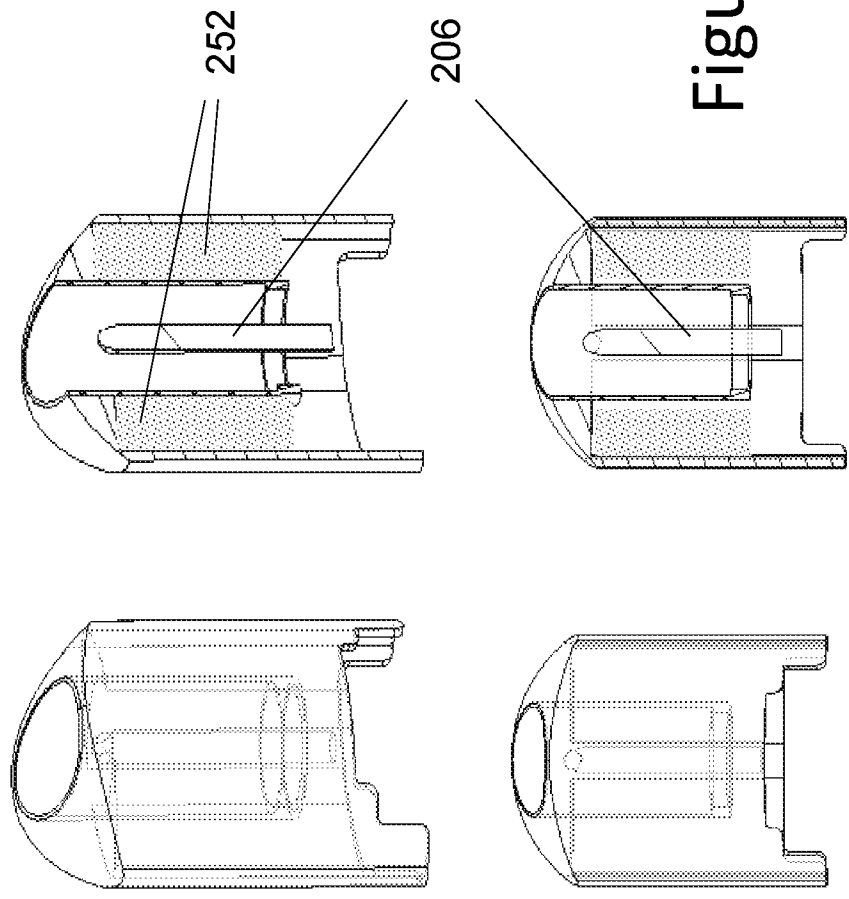

Figure 2k

24/53

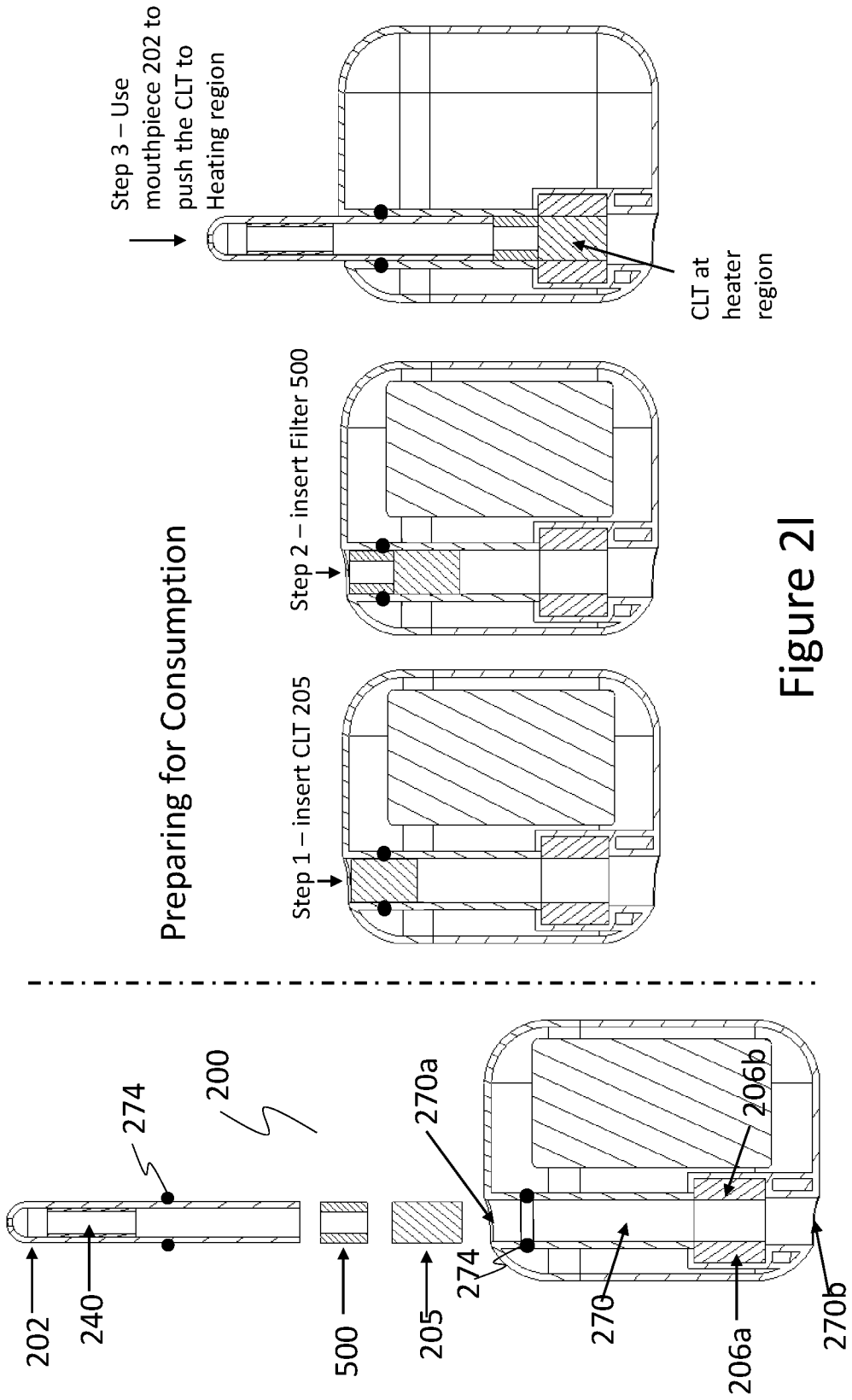

Figure 21

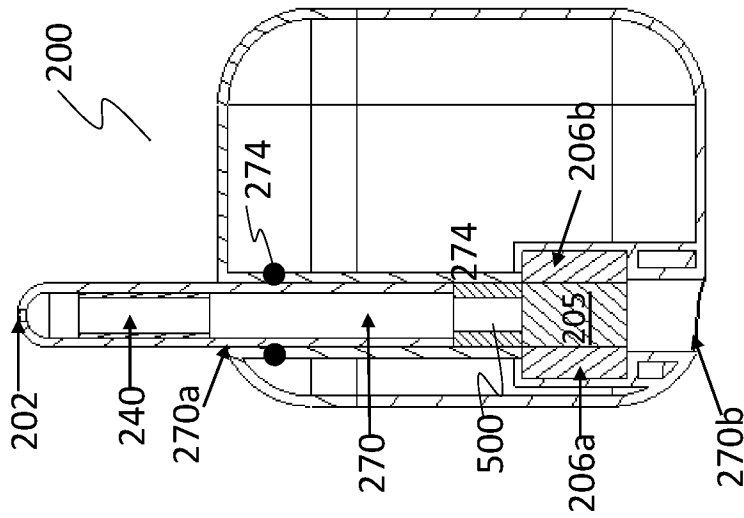
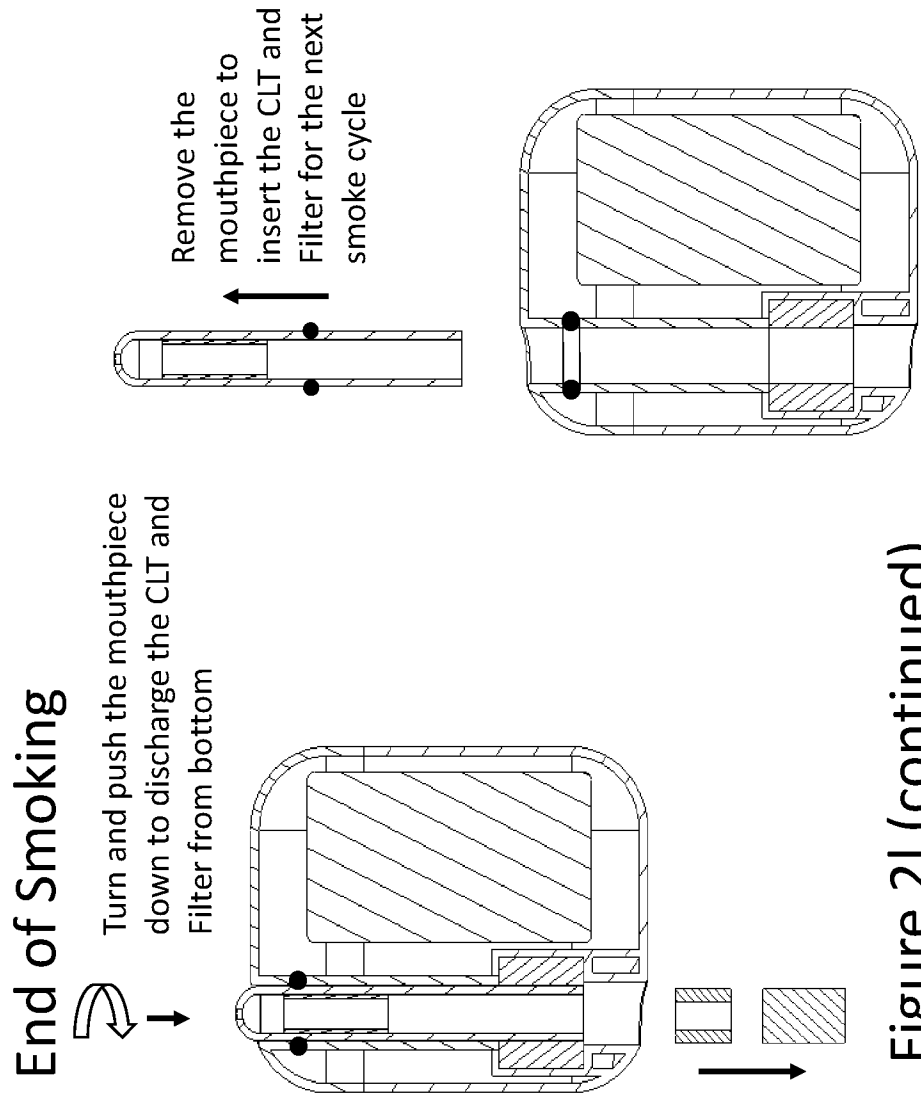

Figure 2I (continued)

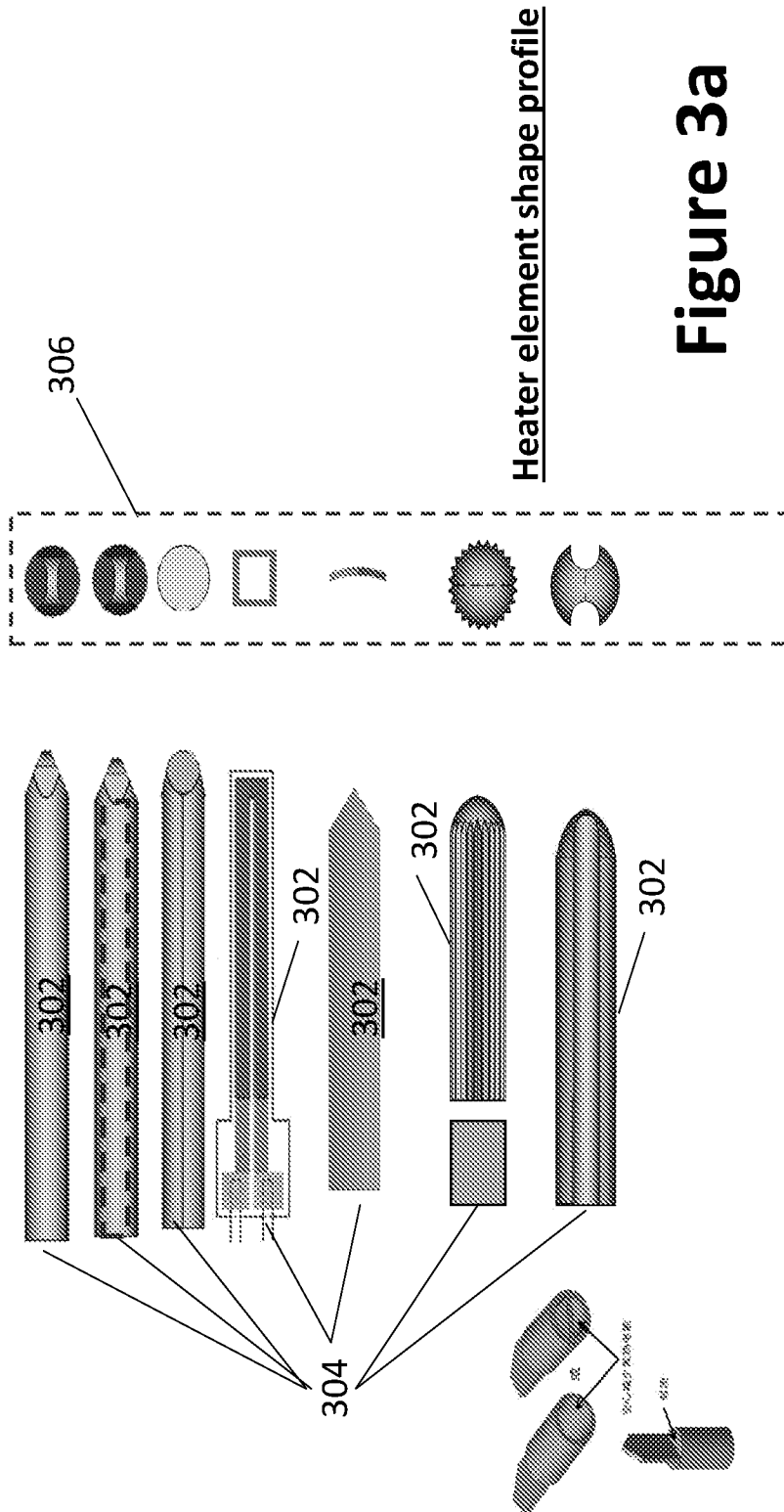

Figure 3a

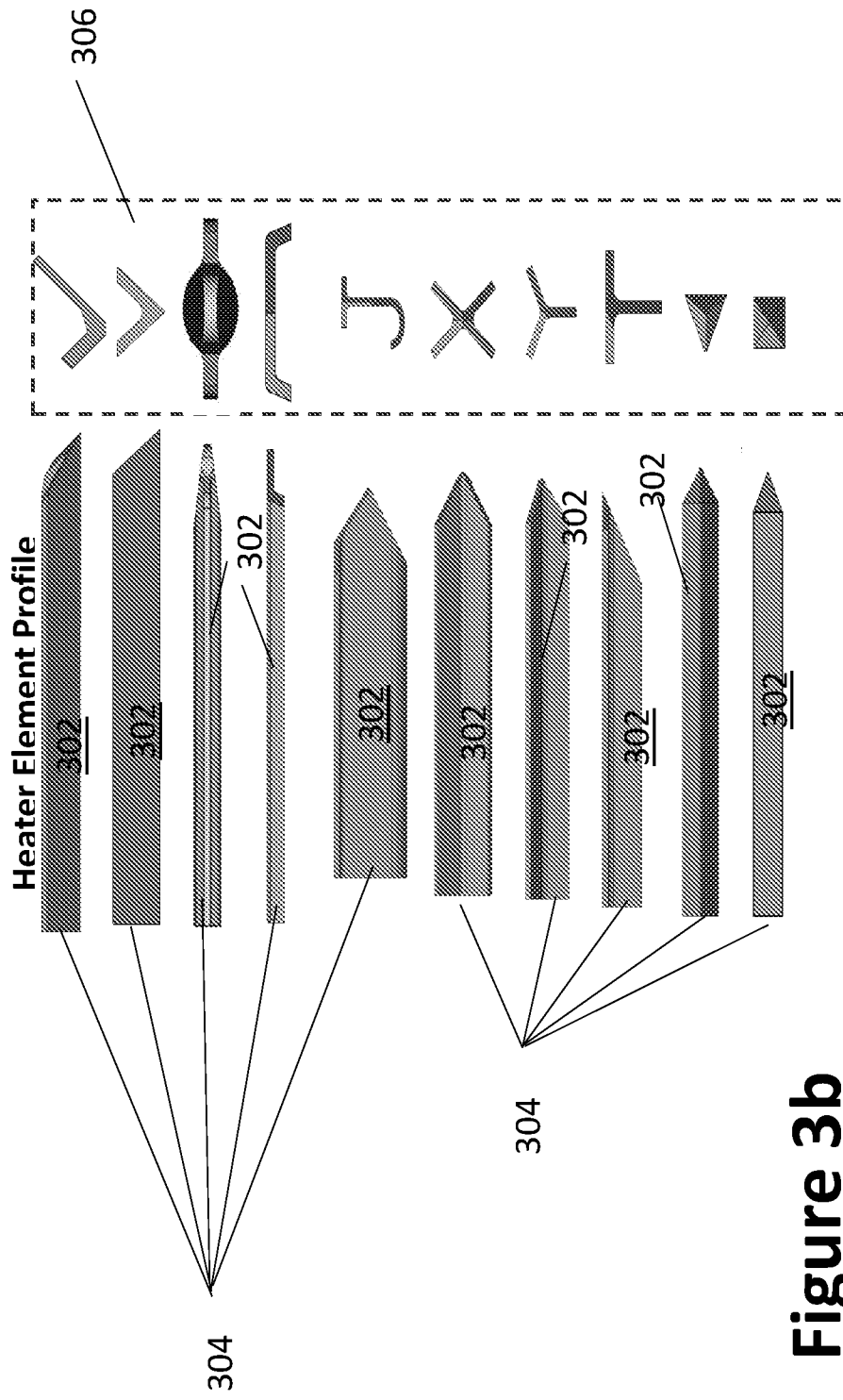

Figure 3b

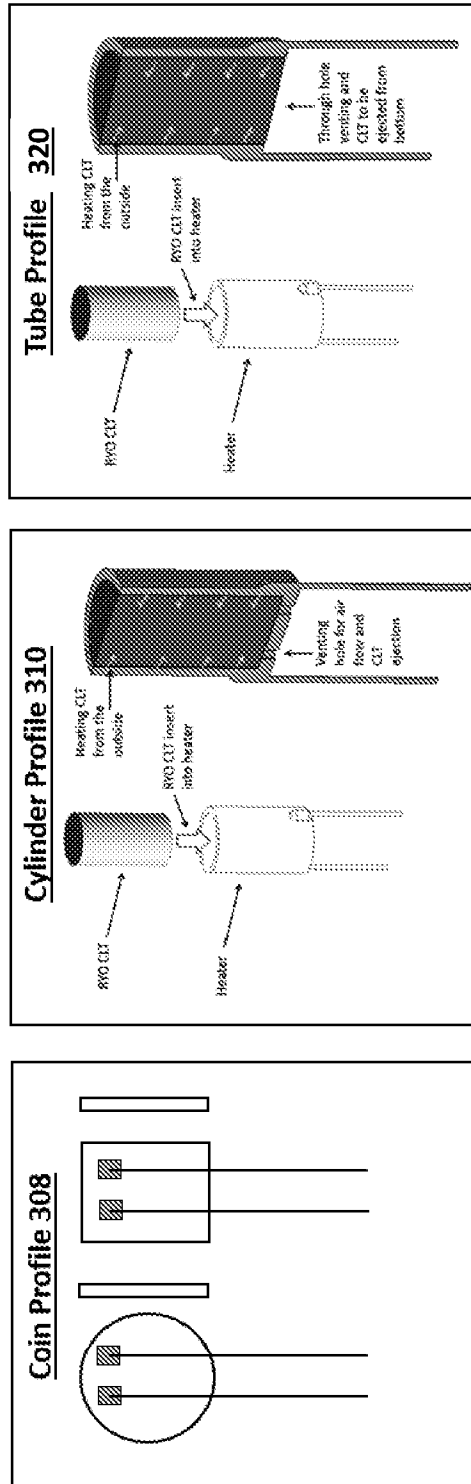

Figure 3c

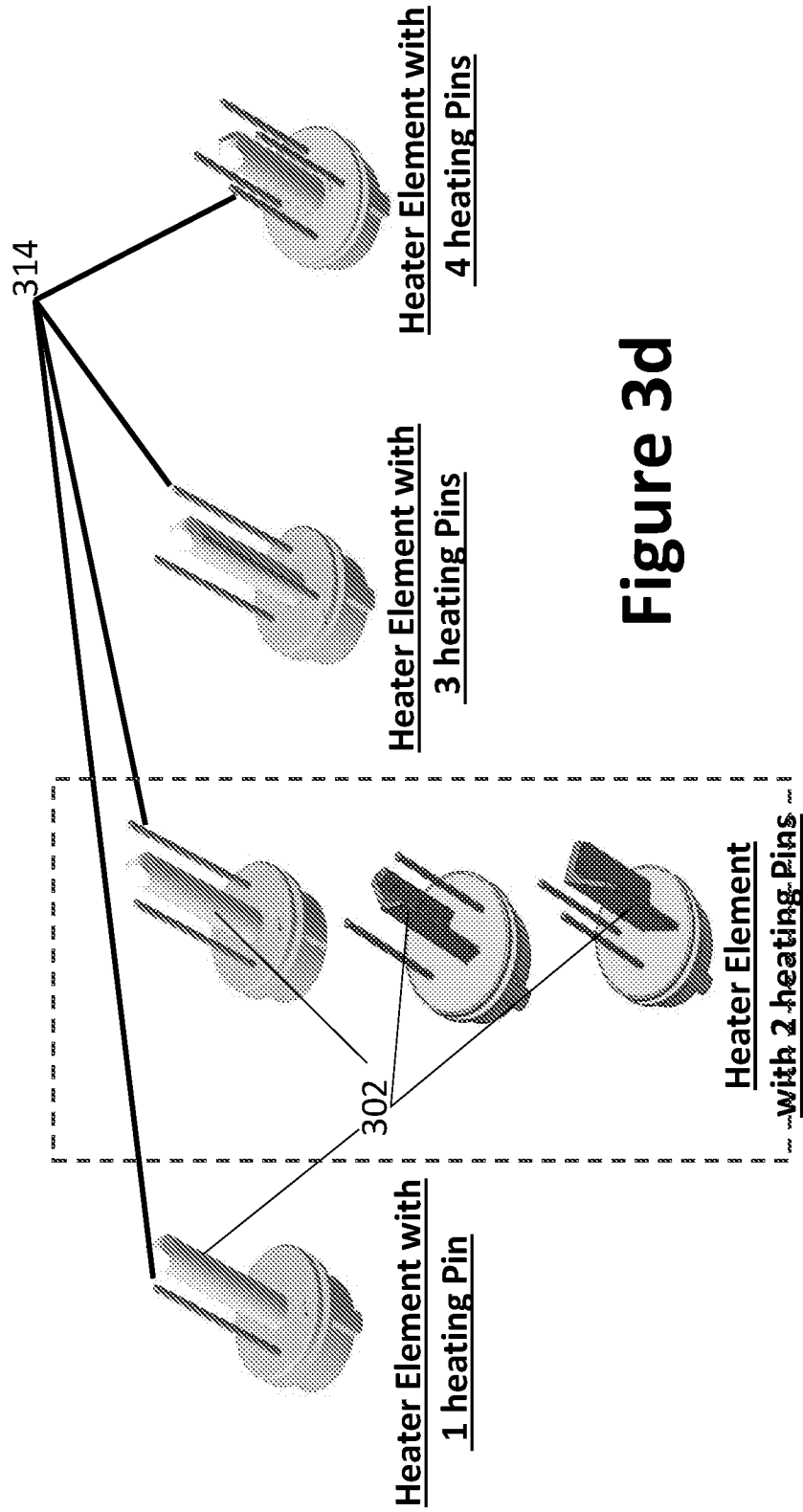

Figure 3d

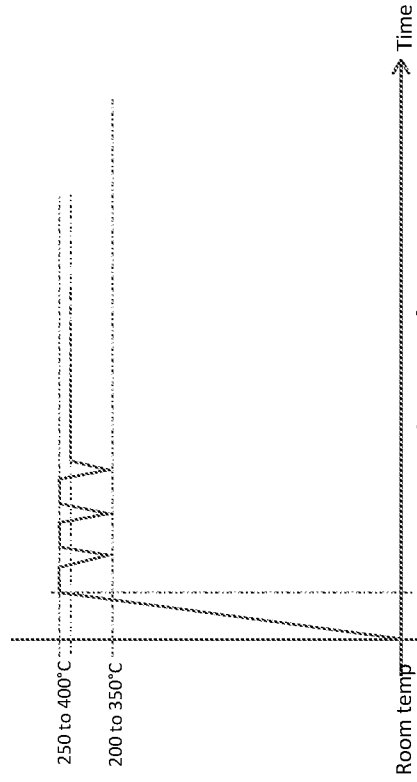

Figure 4b

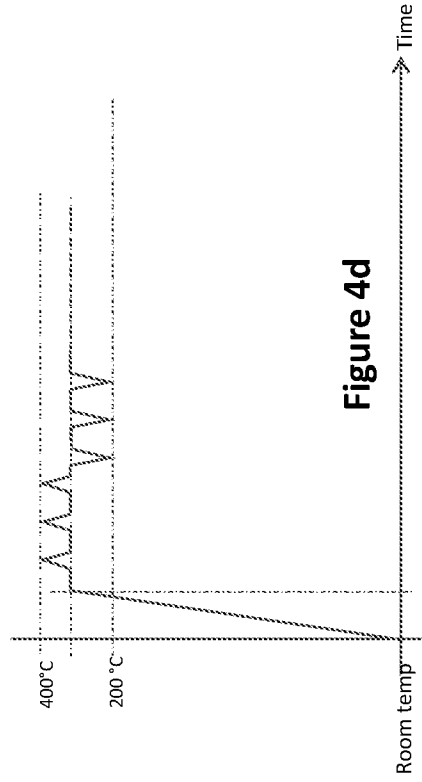

Figure 4d

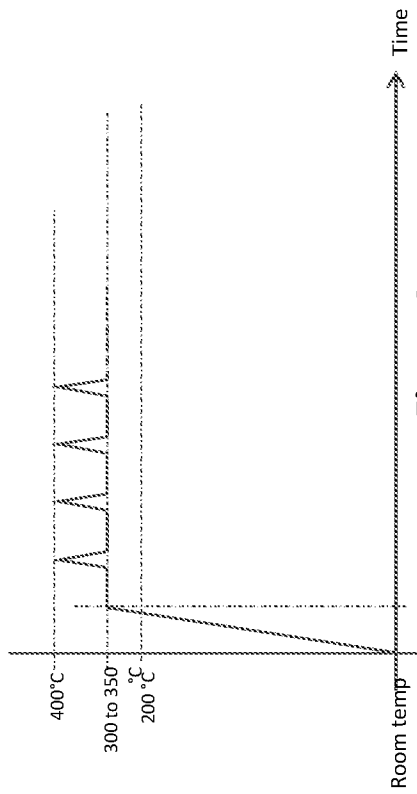

Figure 4a

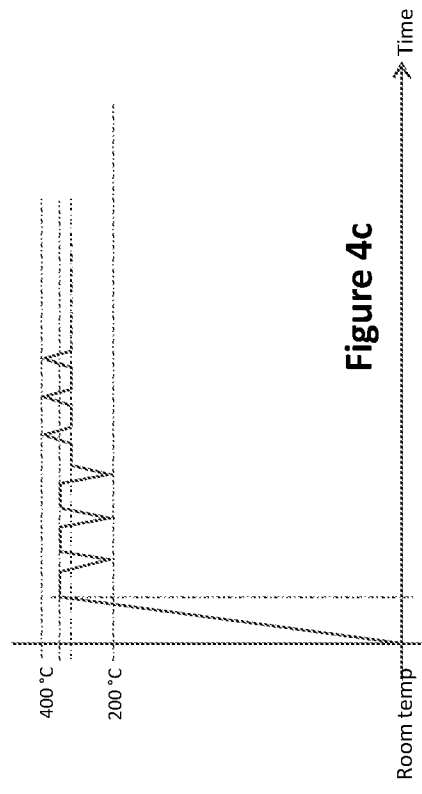

Figure 4c

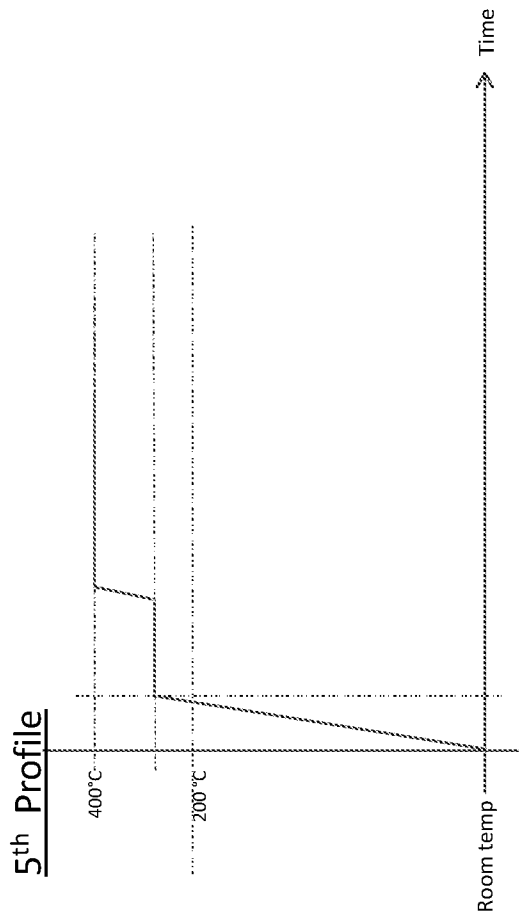

Figure 4e

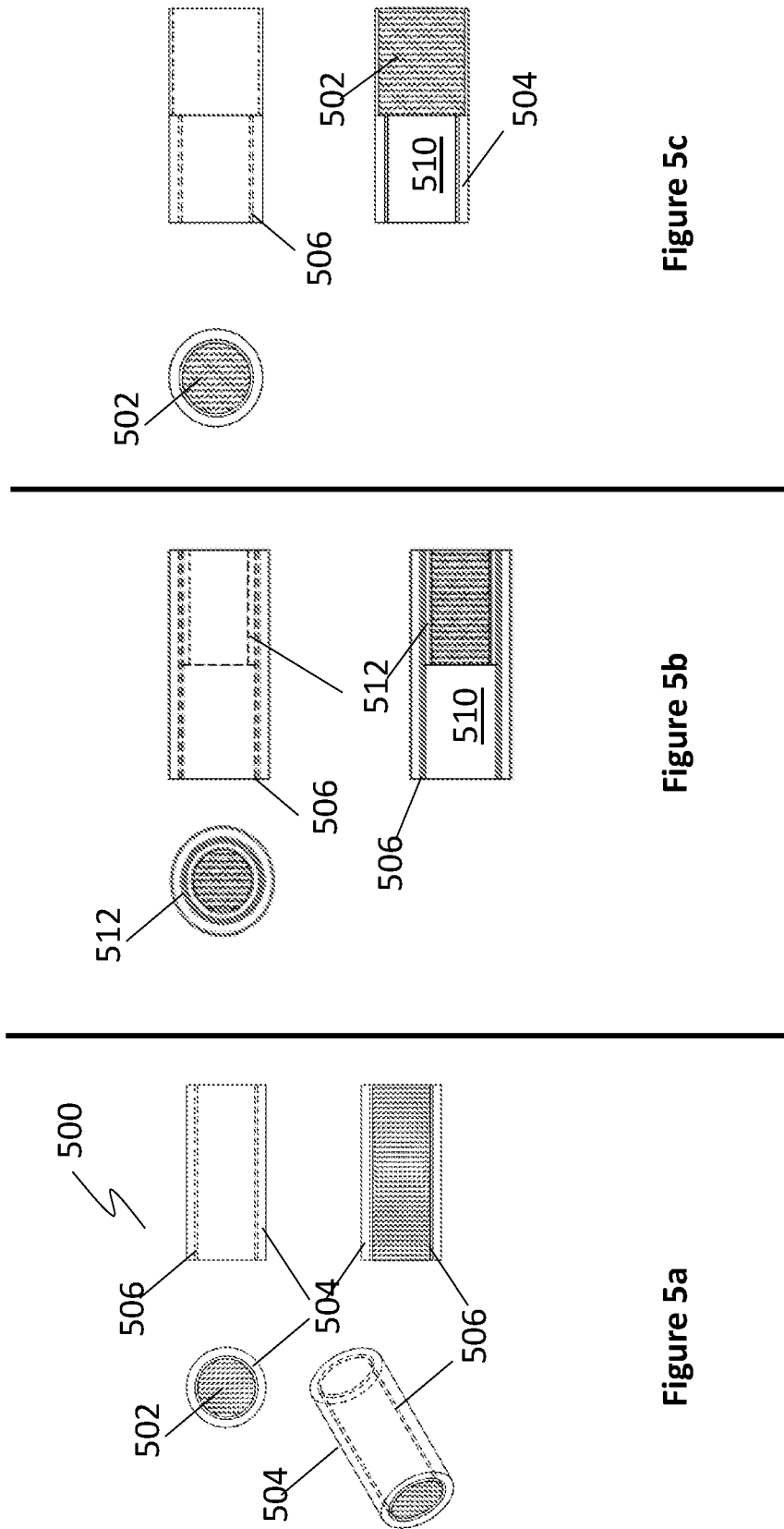

Figure 5c

Figure 5b

Figure 5a

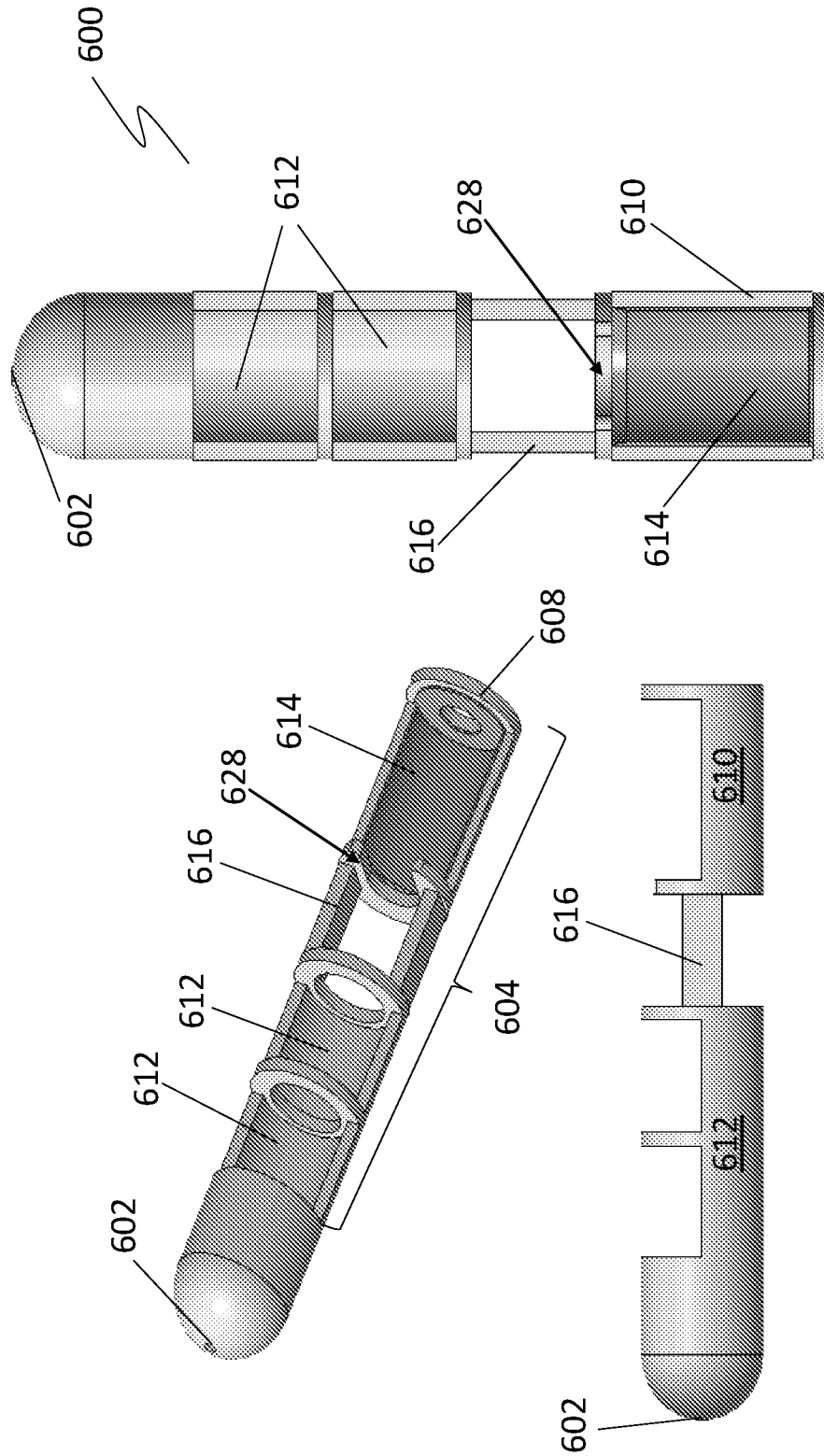

Figure 6a

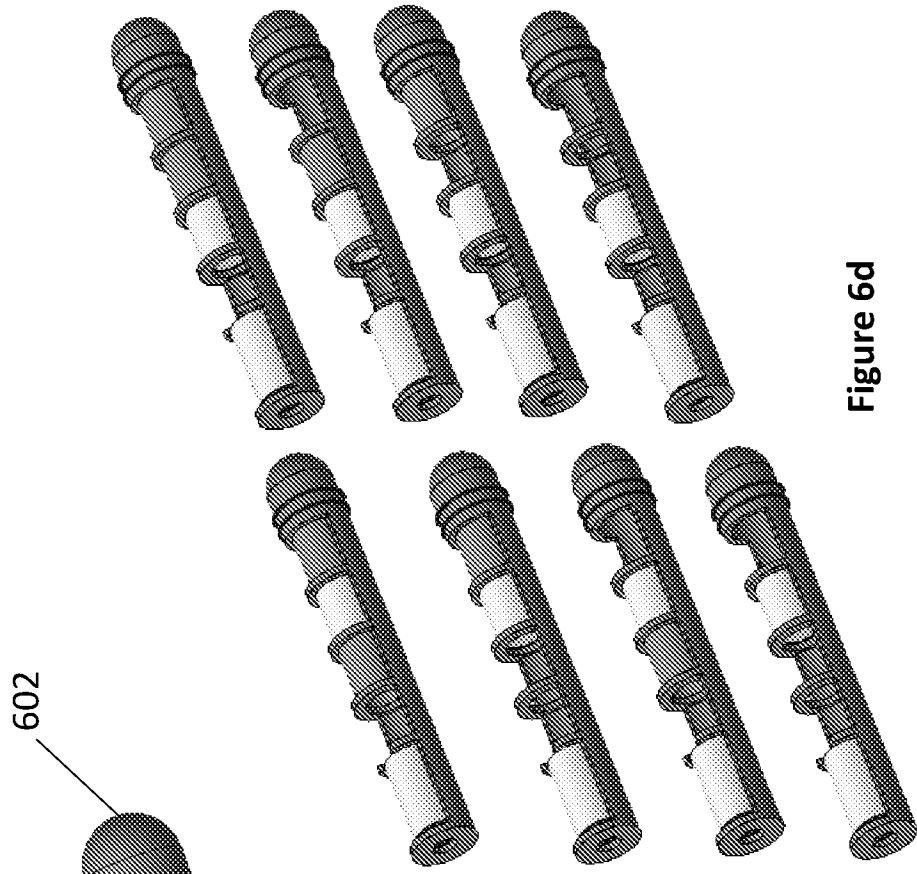

Figure 6d

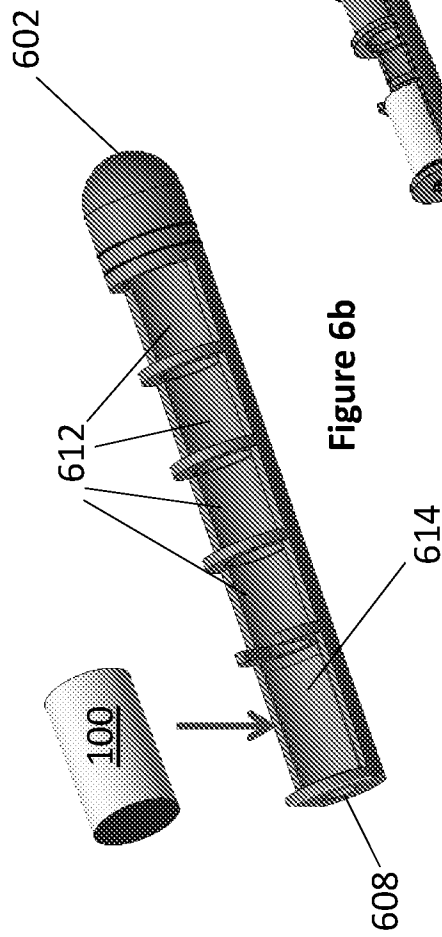

Figure 6b

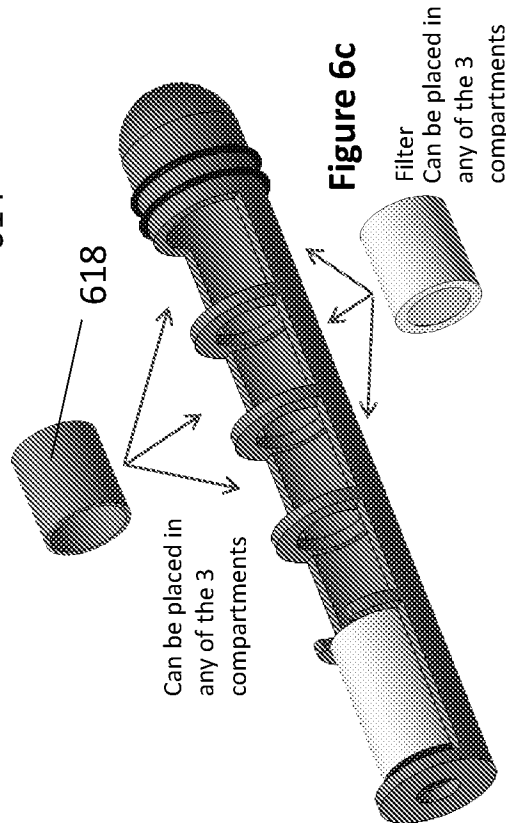

Figure 6c

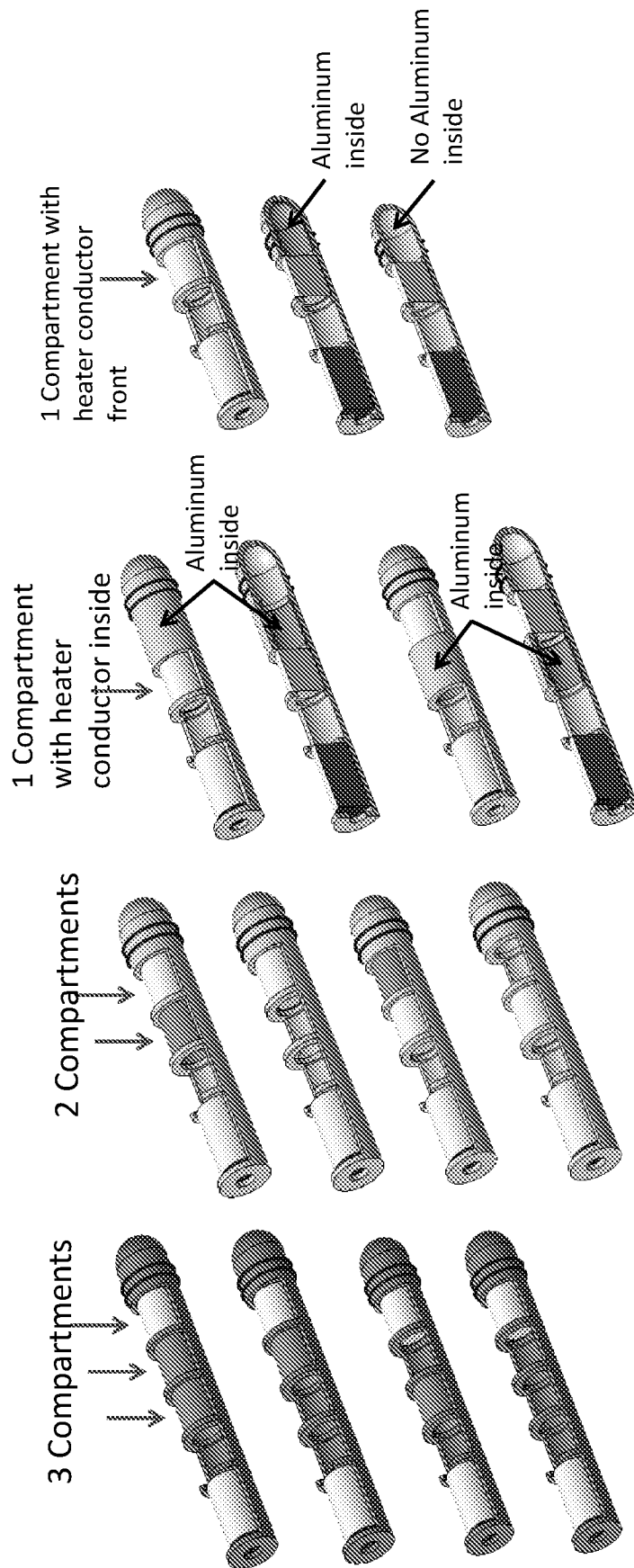

Figure 6e

36/53

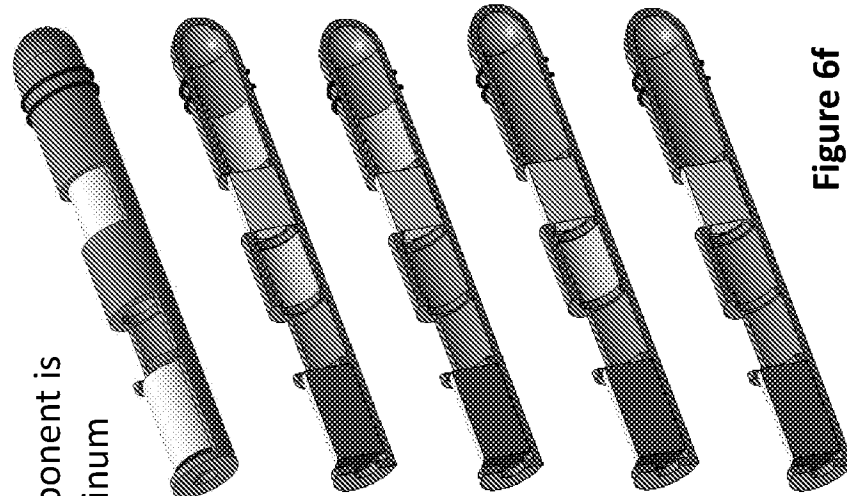
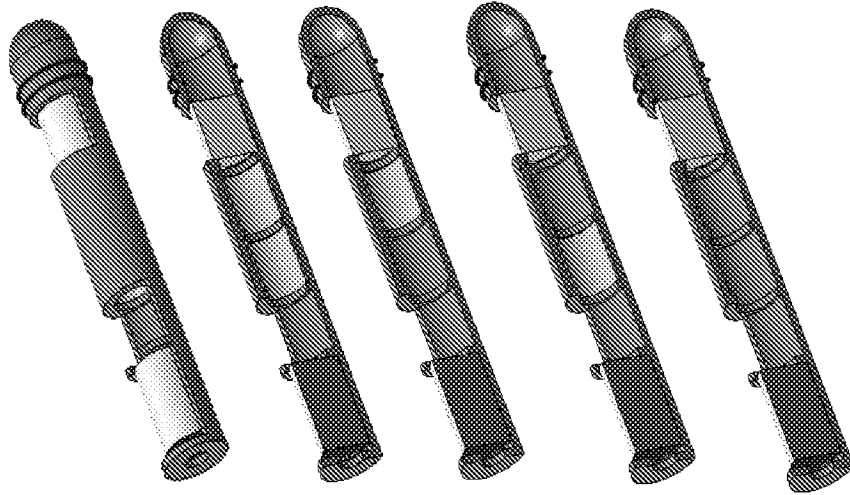
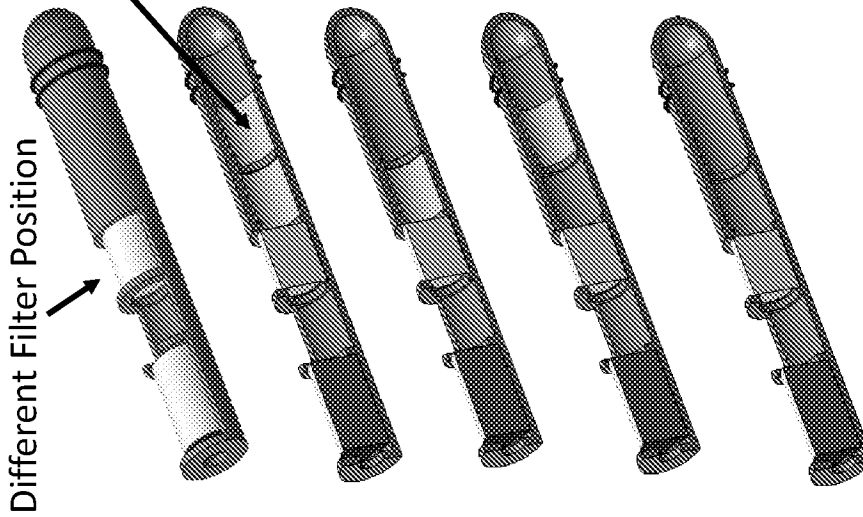

Figure 6f

Component is
aluminum



Different Filter Position

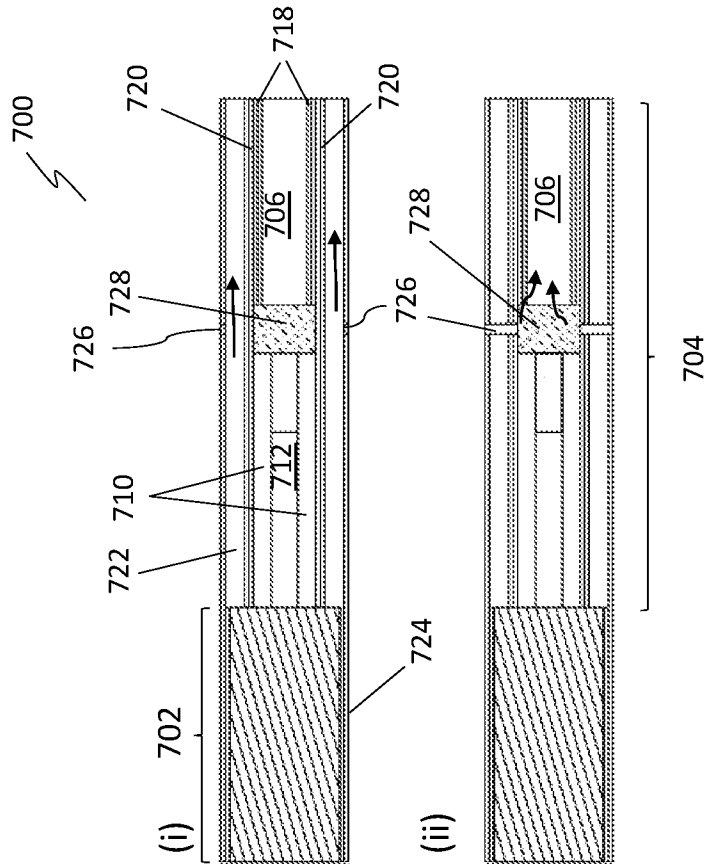

Figure 7b

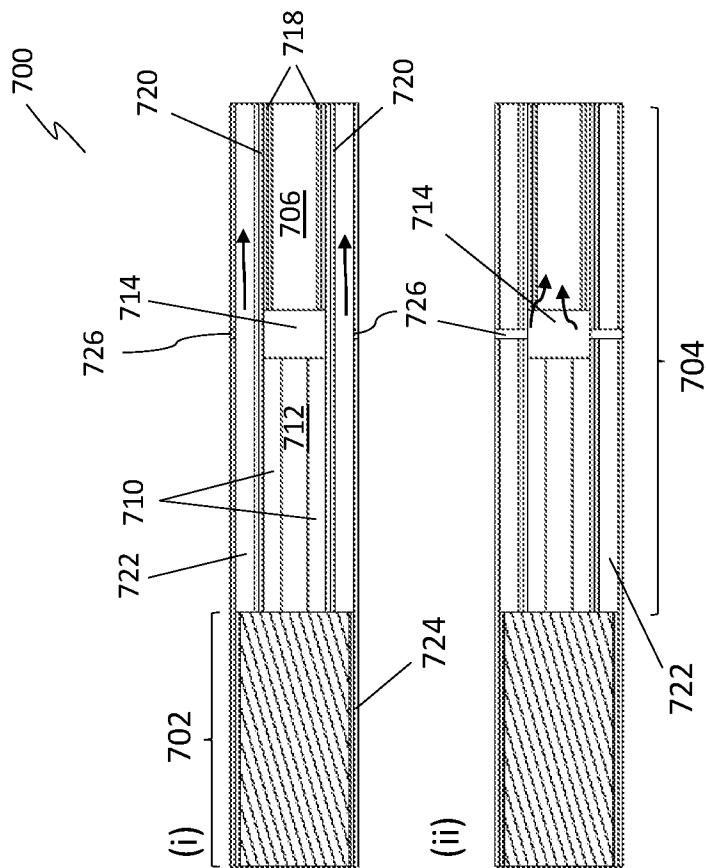

Figure 7a

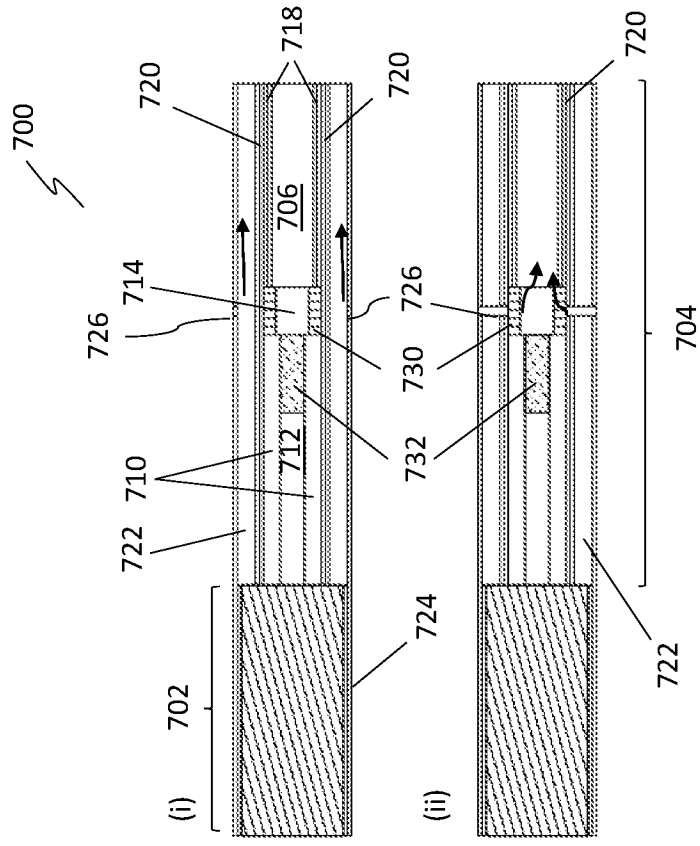

Figure 7c

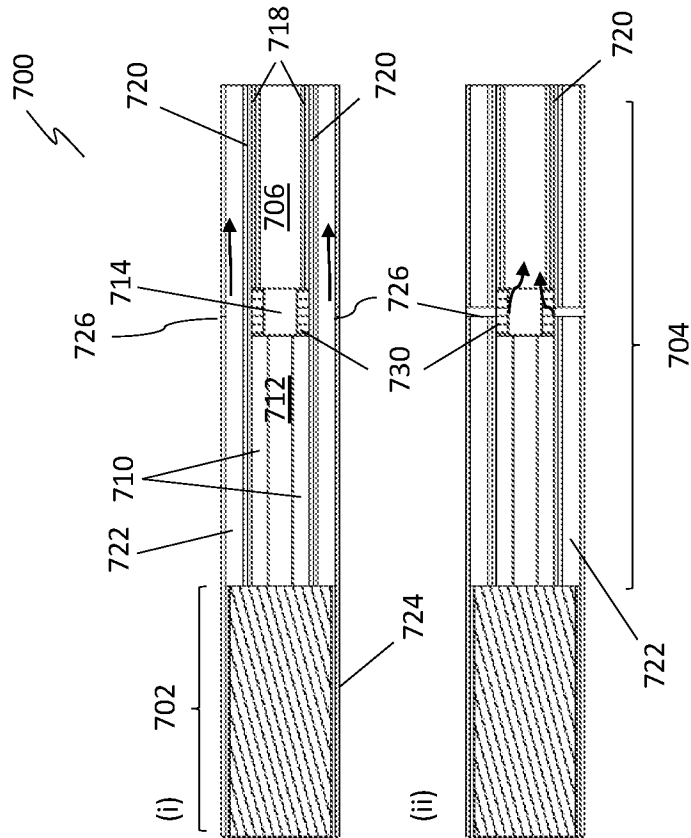

Figure 7d

39/53

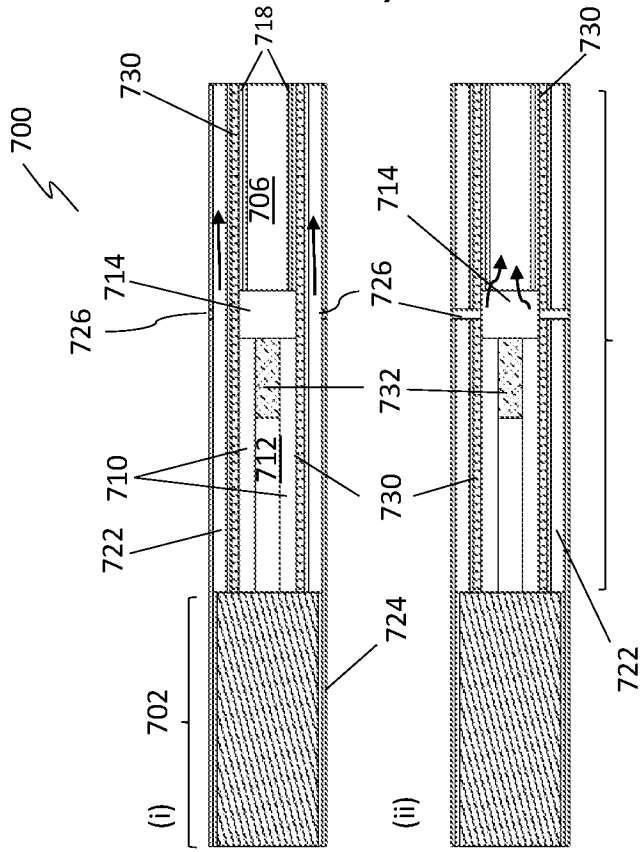

Figure 7f

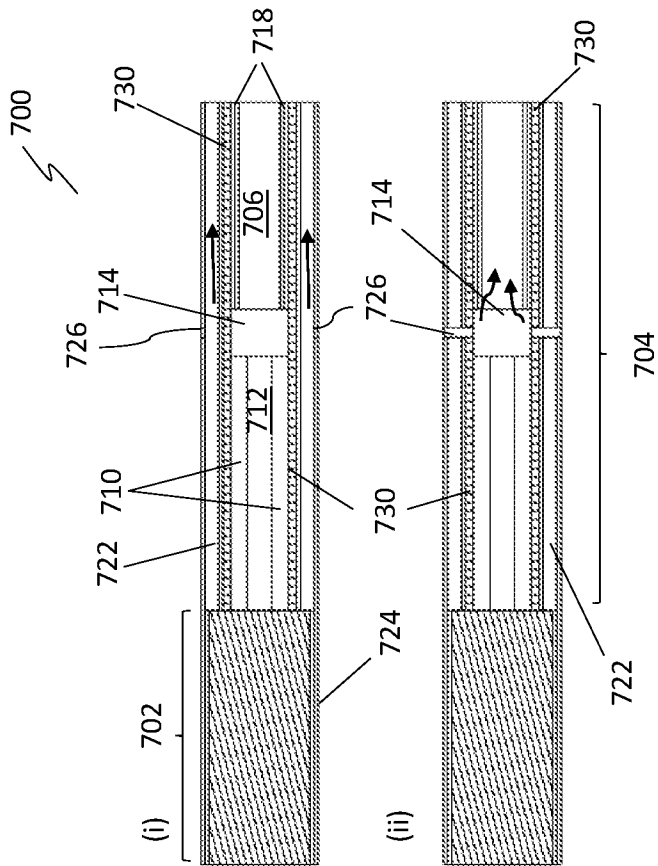

Figure 7e

40/53

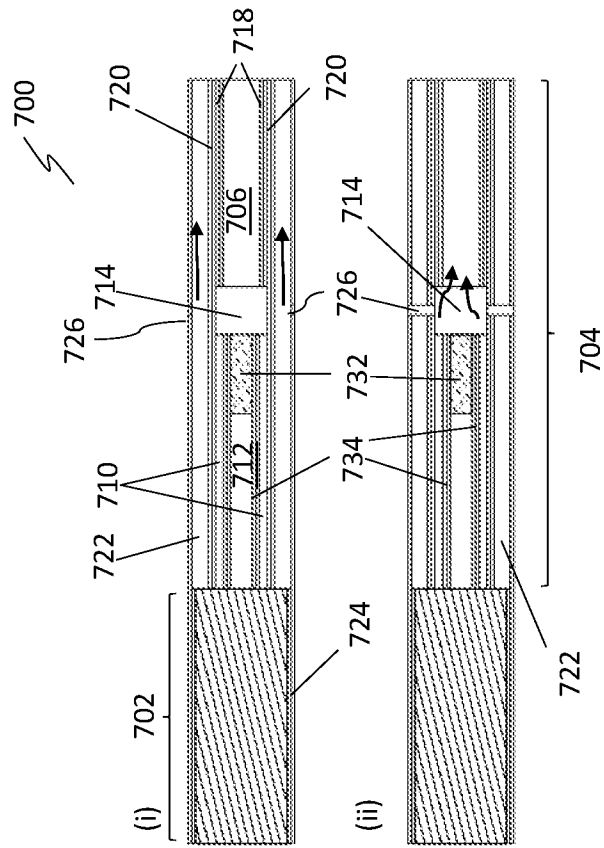

Figure 7h

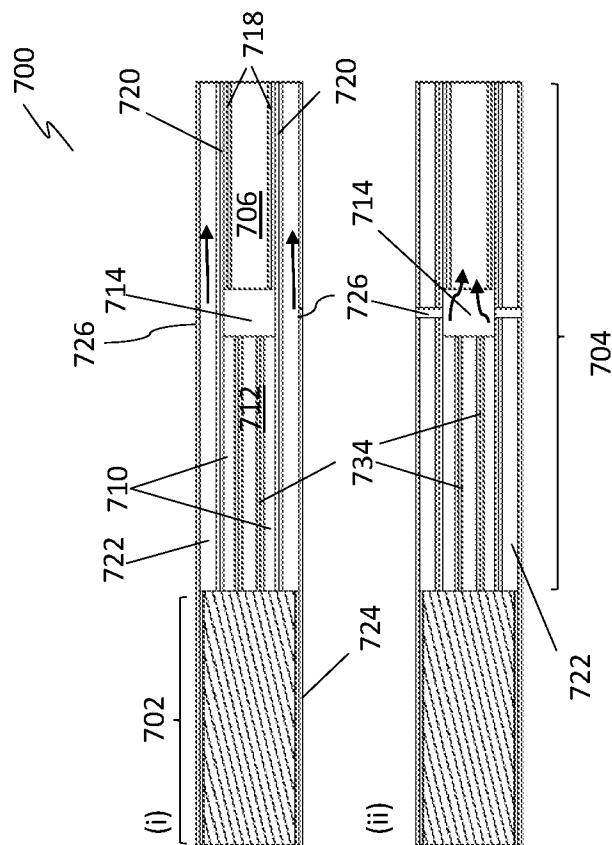

Figure 7g

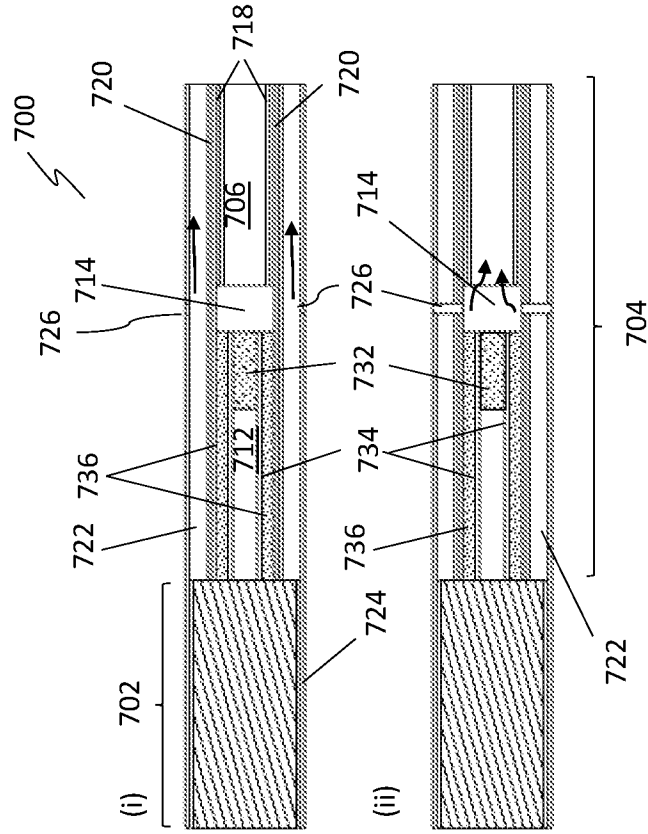

Figure 7j

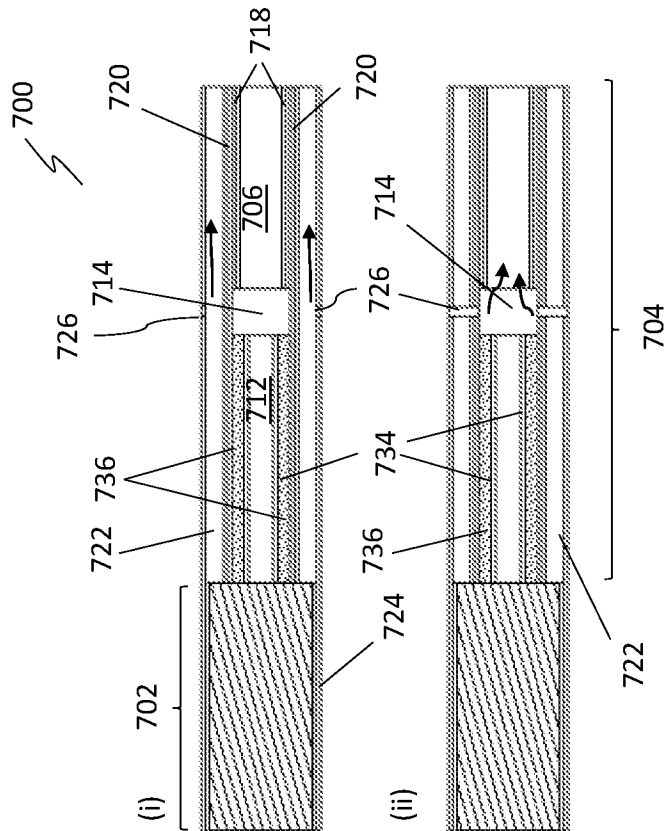

Figure 7i

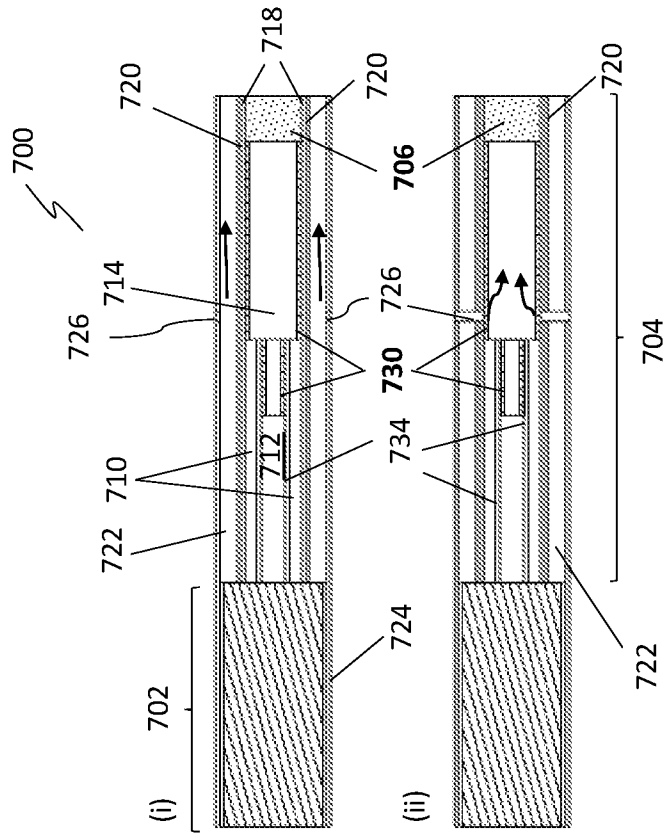

Figure 7i

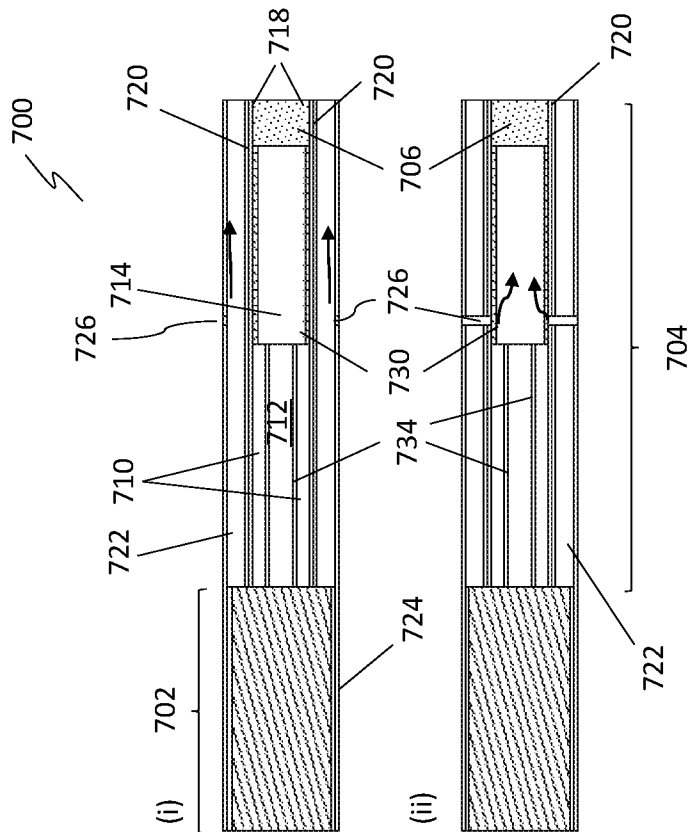

Figure 7k

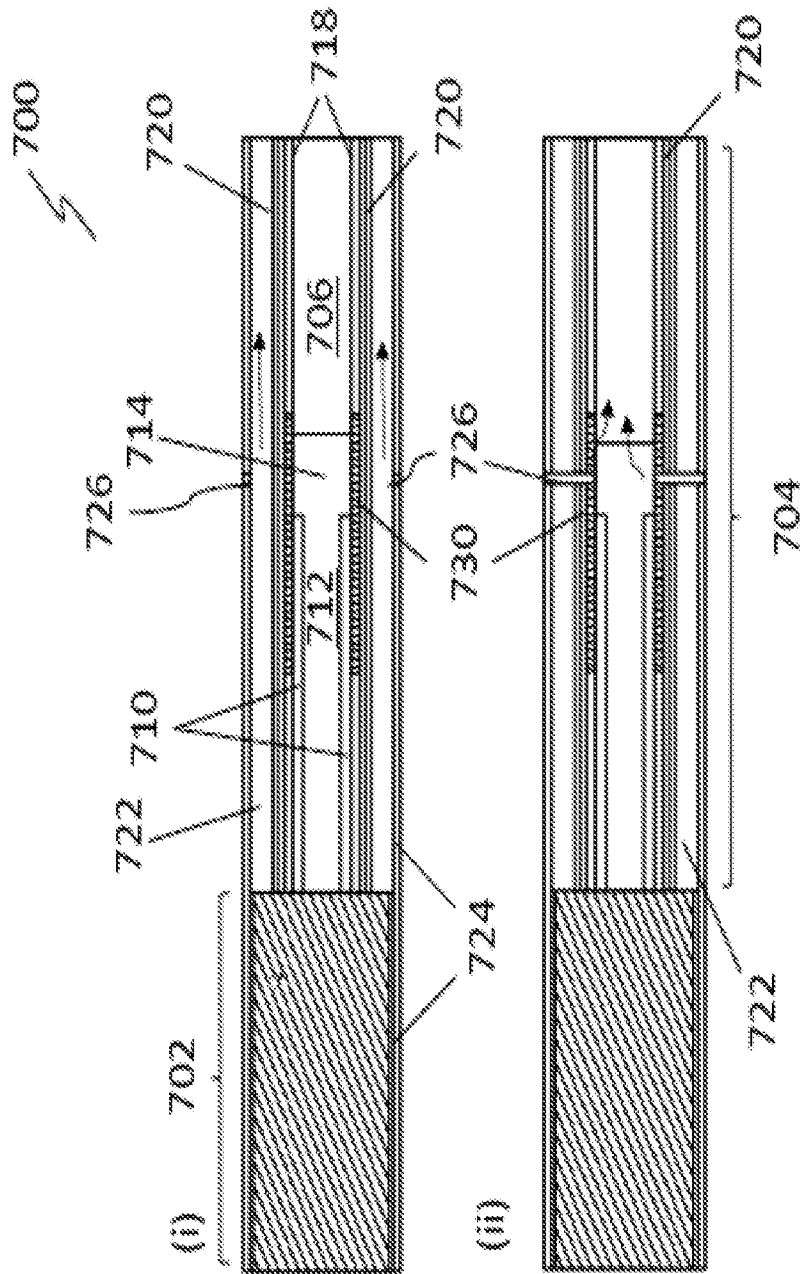

Figure 7m

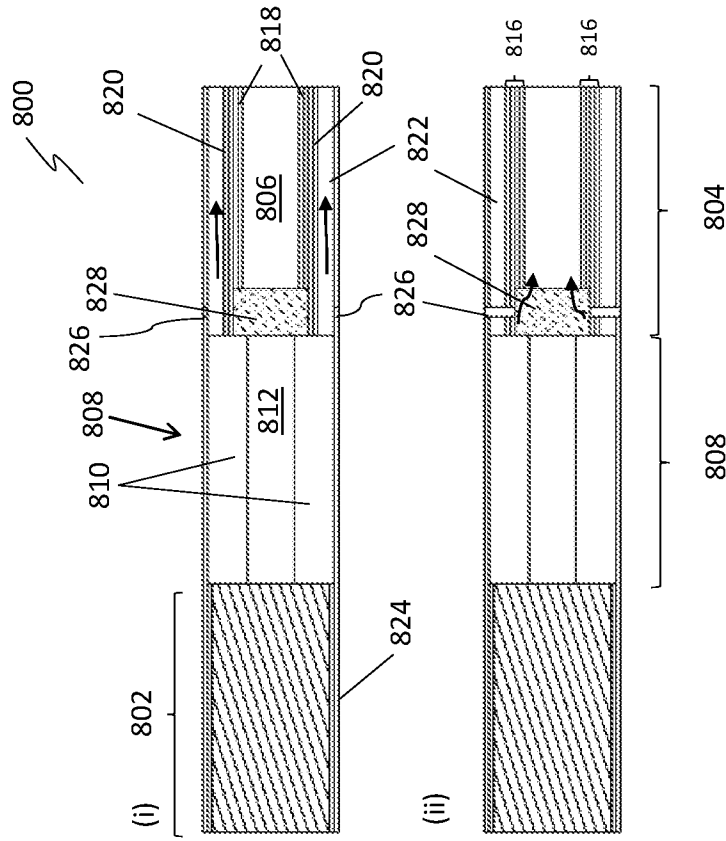

Figure 8b

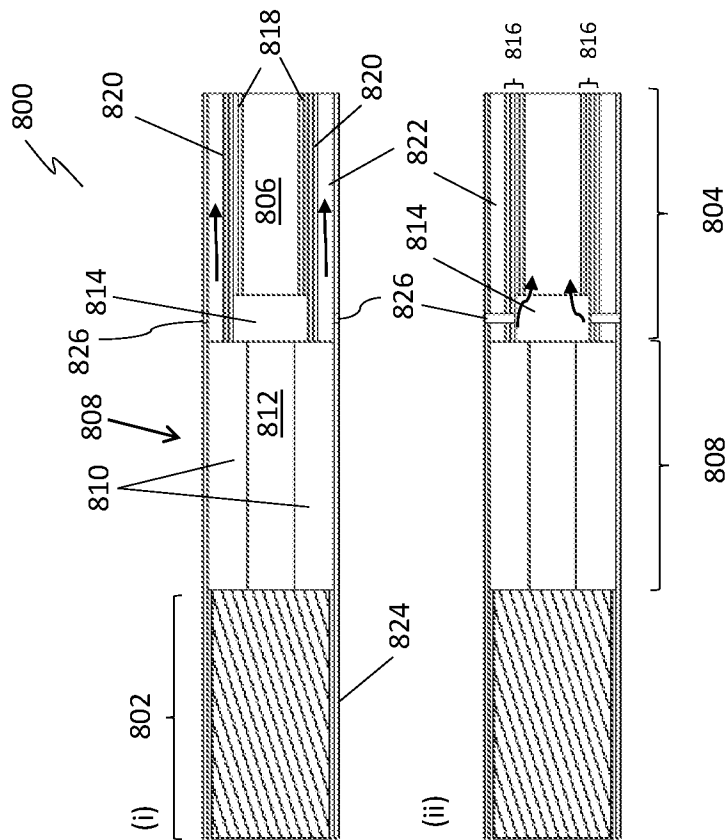

Figure 8a

45/53

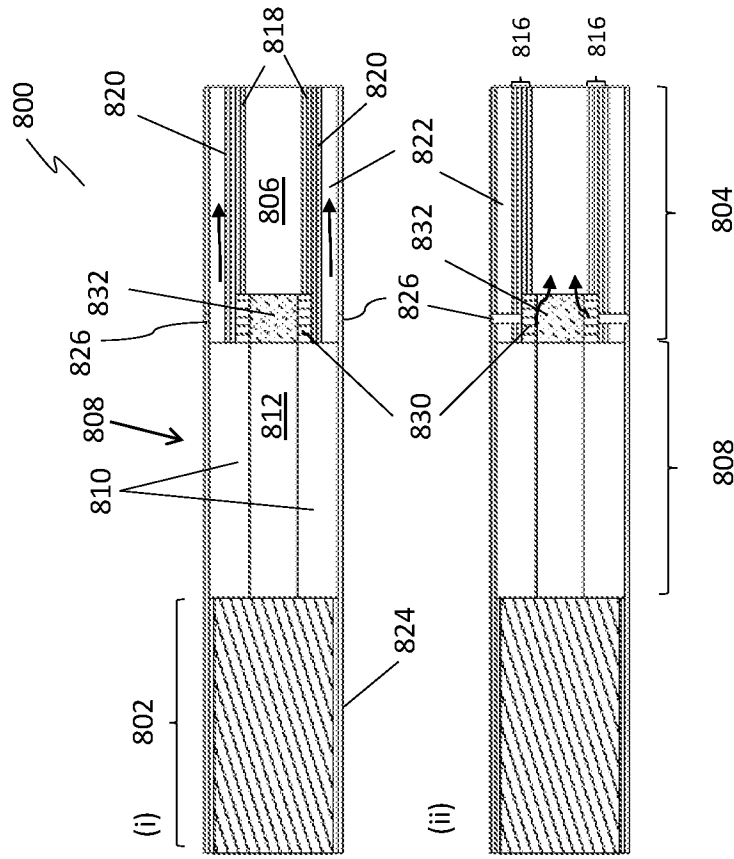

Figure 8d

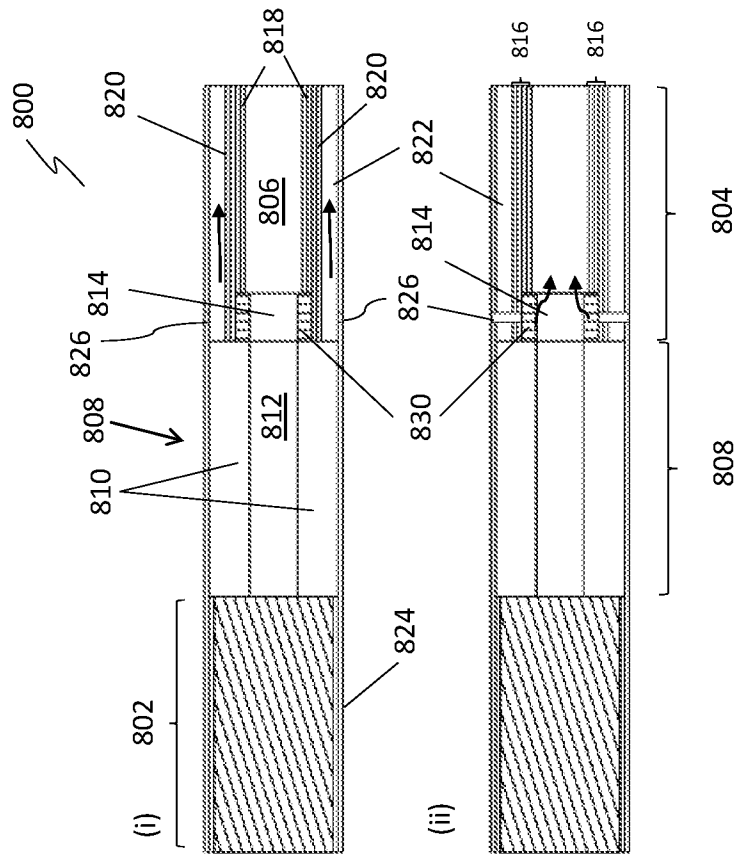

Figure 8c

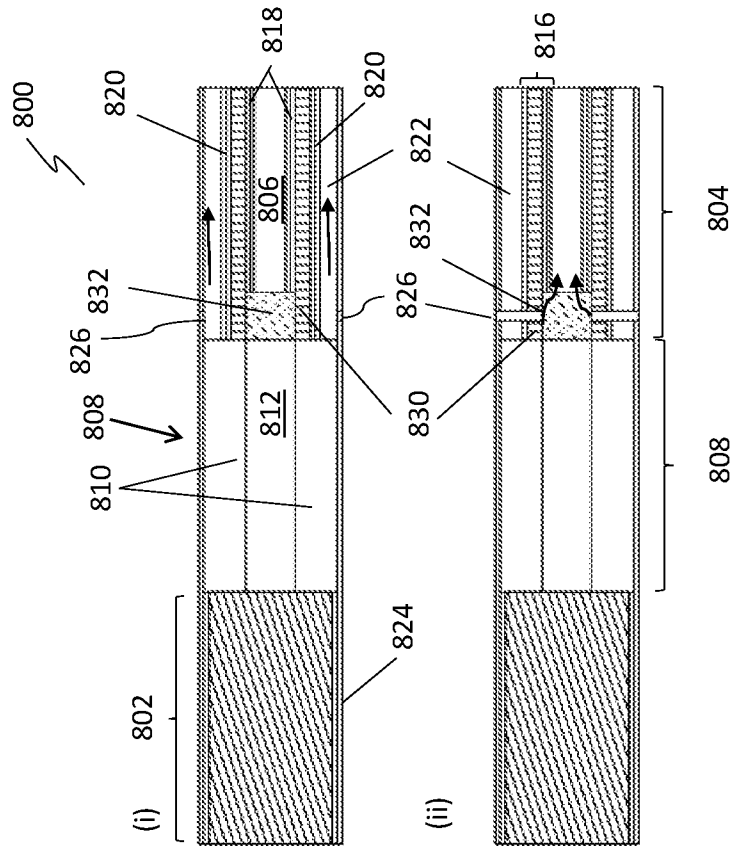

Figure 8f

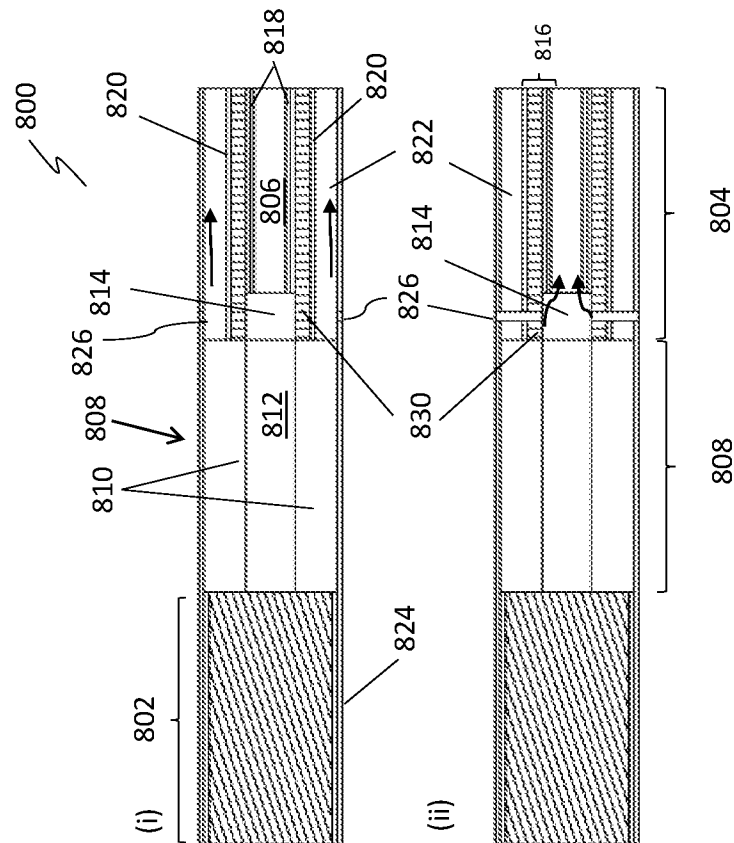

Figure 8e

47/53

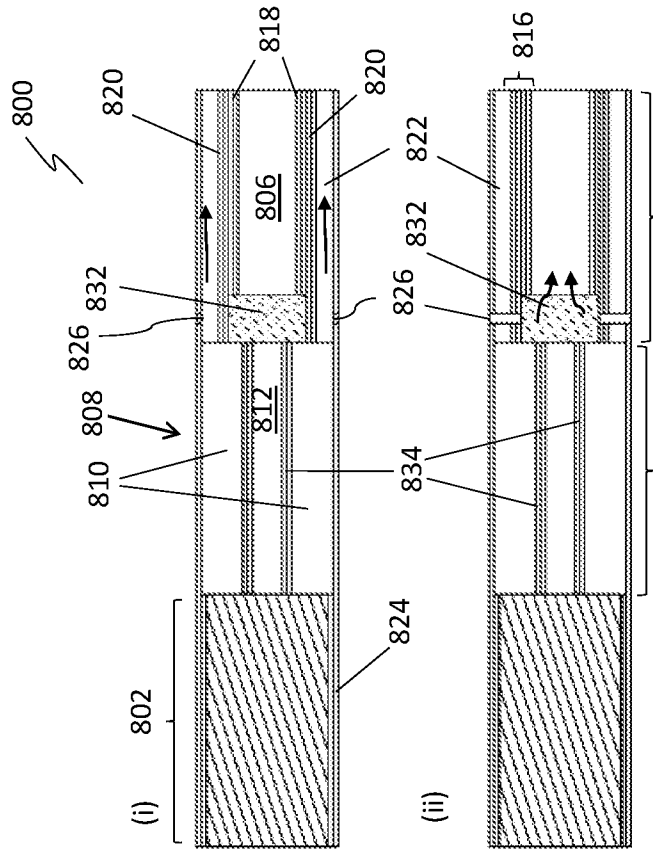

Figure 8g

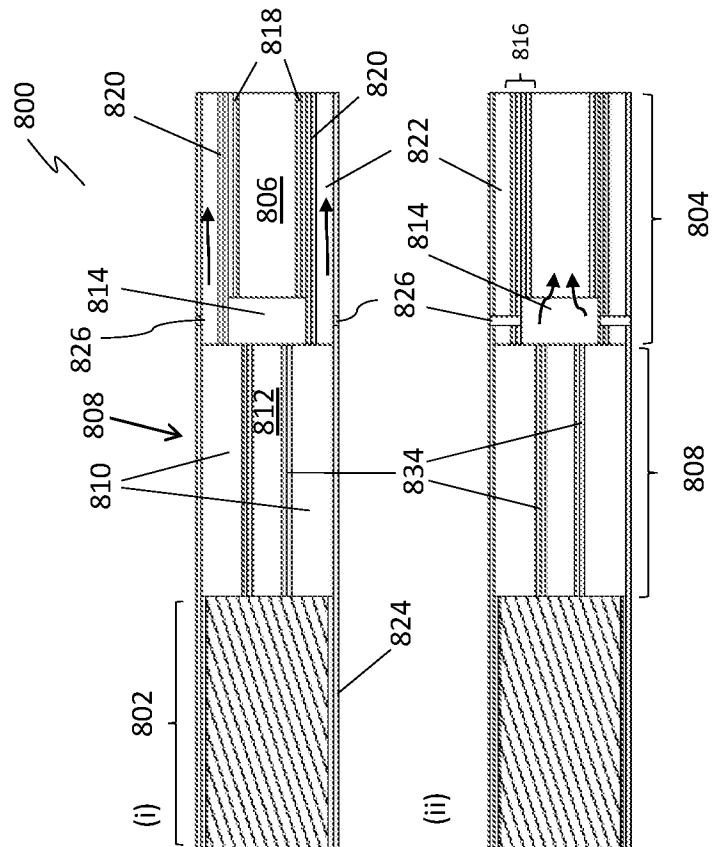

Figure 8h

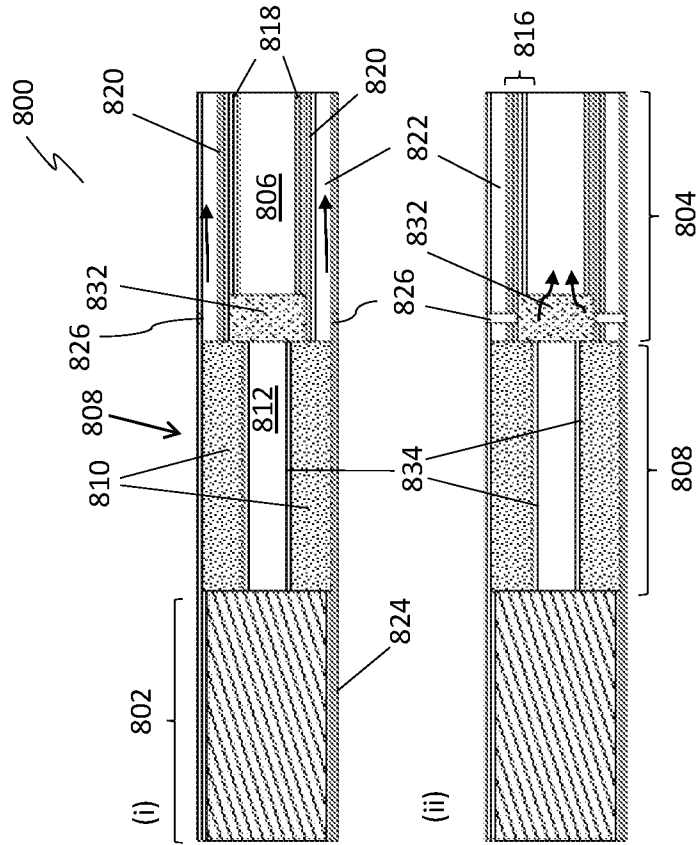

Figure 8j

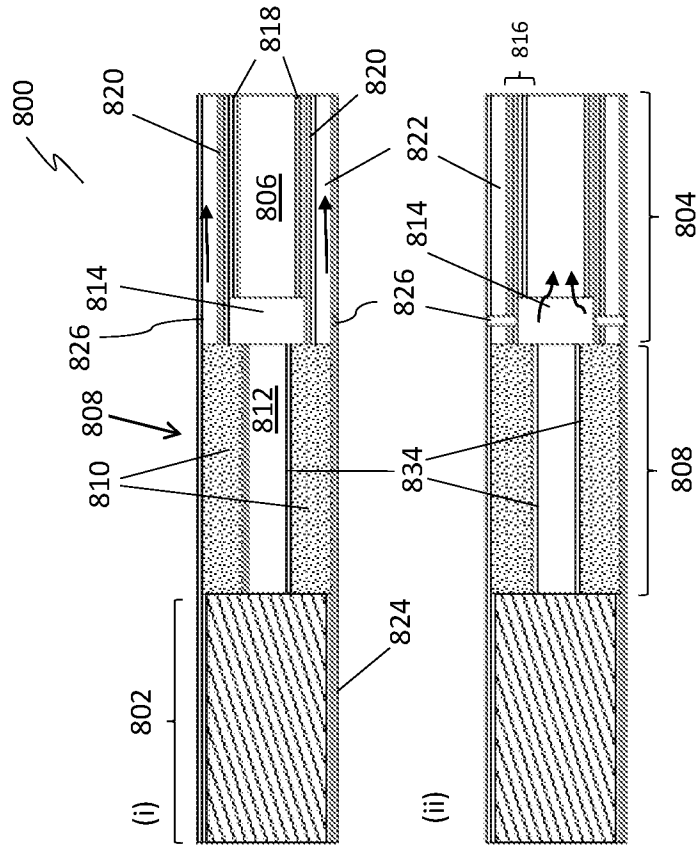

Figure 8i

49/53

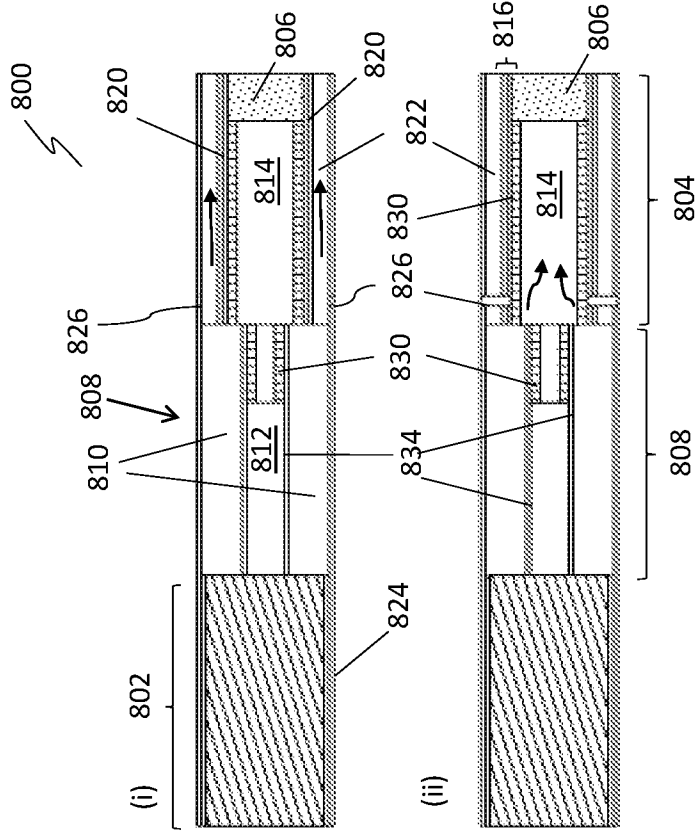

Figure 8l

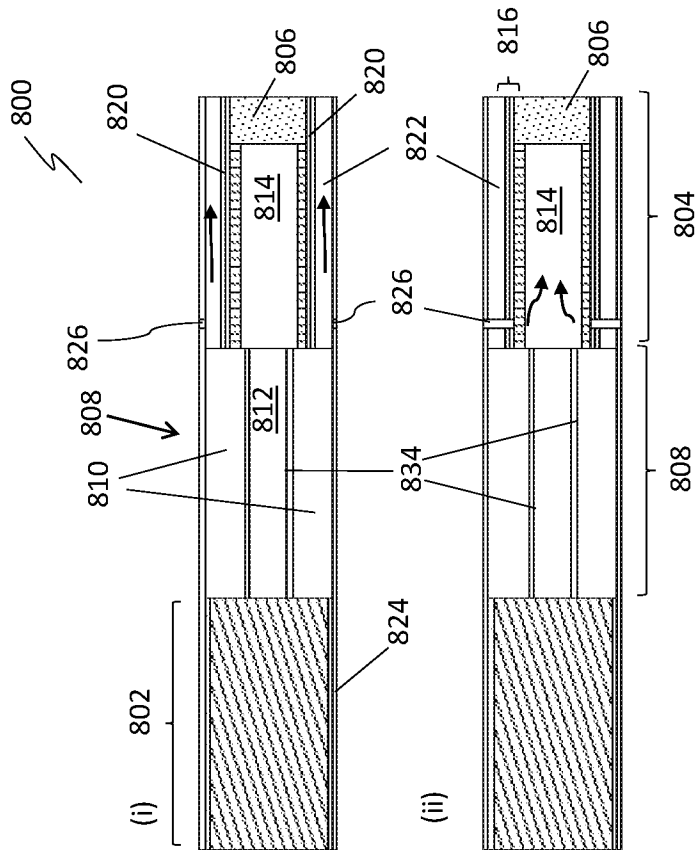

Figure 8k

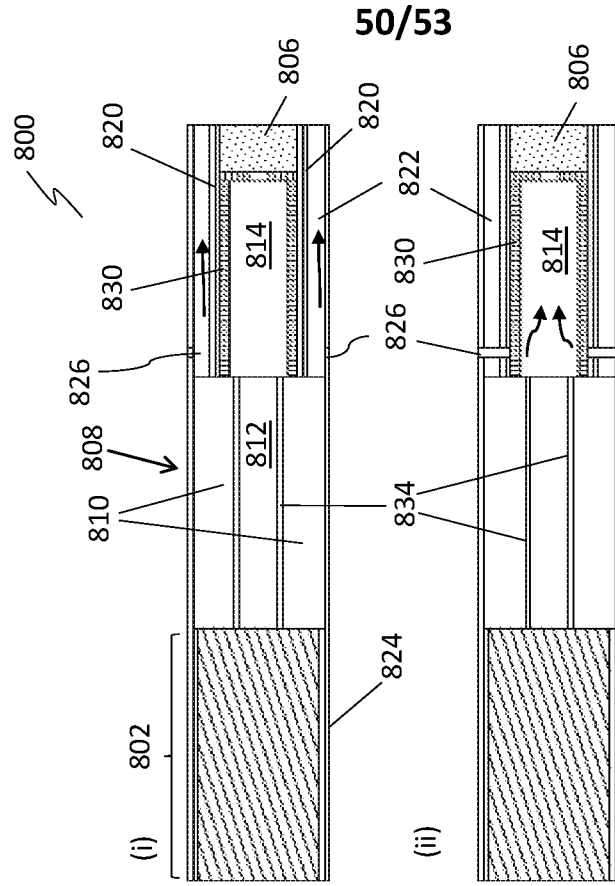

Figure 8n

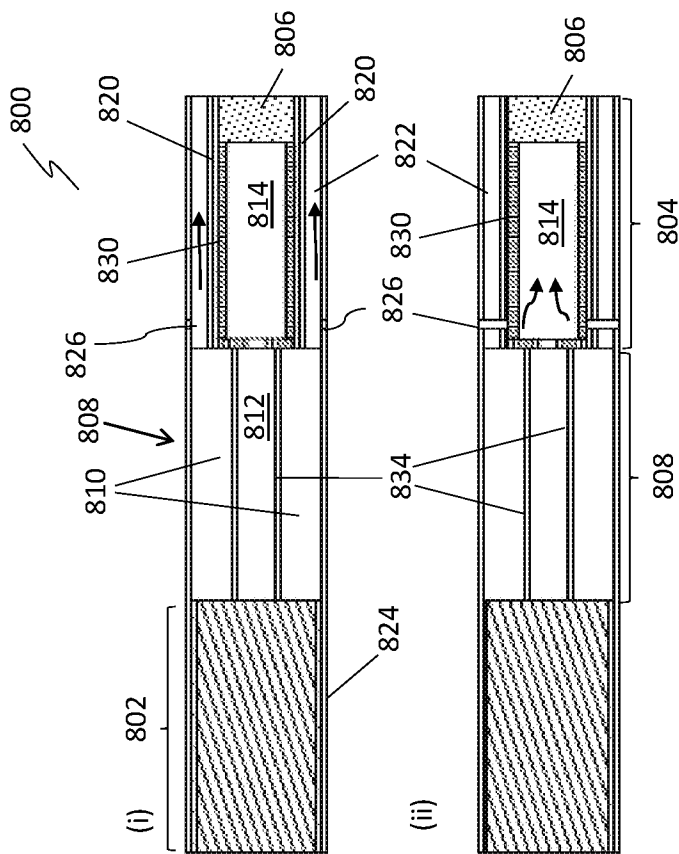

Figure 8m

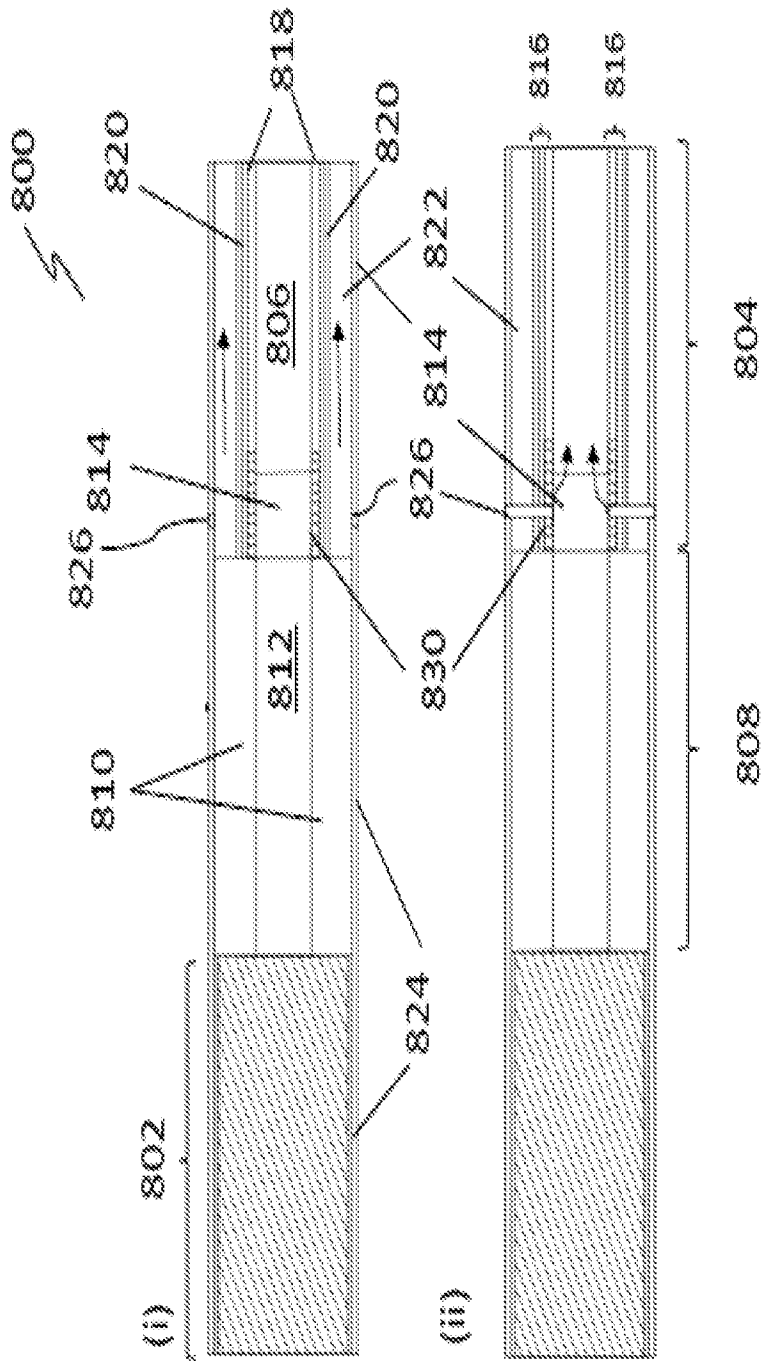
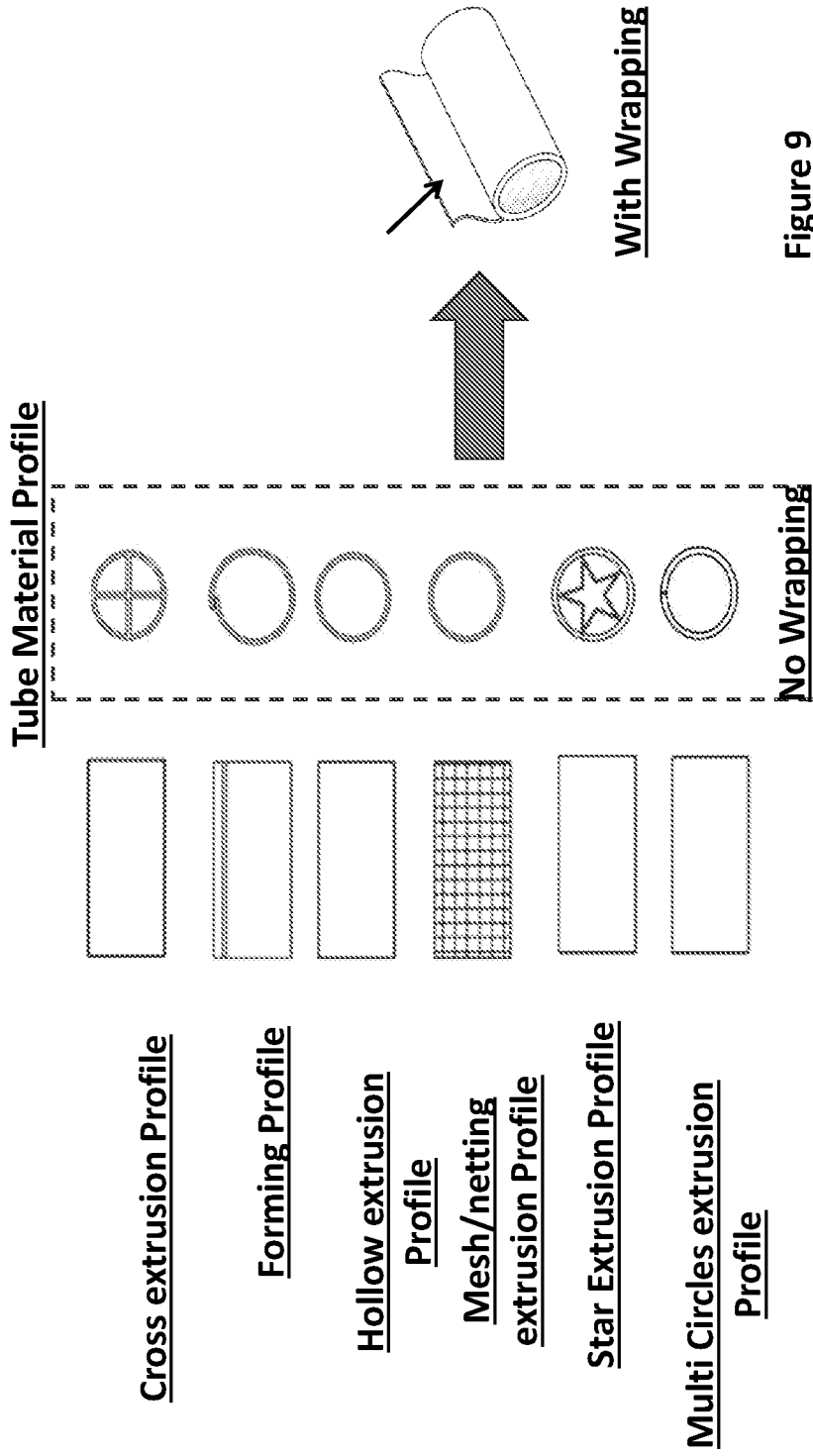

Figure 80



Tube Profile for Heat Stick

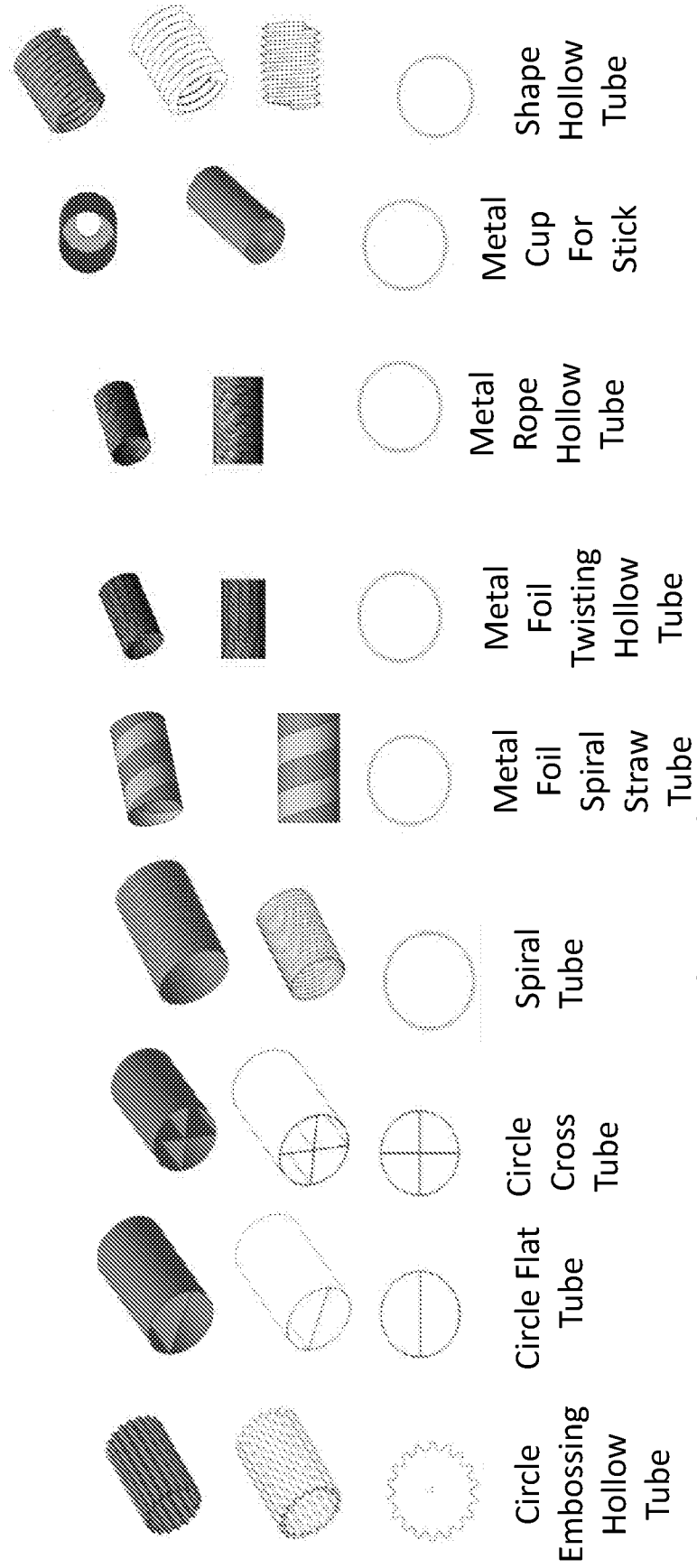

Figure 9 (continued)

INTERNATIONAL SEARCH REPORT

International application No.

PCT/SG2022/050164

A. CLASSIFICATION OF SUBJECT MATTER**A24F 40/40 (2020.01) A24F 40/57 (2020.01) A24F 40/20 (2020.01) A24F 47/00 (2020.01)**

According to International Patent Classification (IPC)

B. FIELDS SEARCHED

Minimum documentation searched (classification system followed by classification symbols)

A24F

Documentation searched other than minimum documentation to the extent that such documents are included in the fields searched

Electronic data base consulted during the international search (name of data base and, where practicable, search terms used)

FAMPAT: Heating, device, apparatus, element, suction, mouthpiece, nosepiece, aerosol, generating, forming, producing, substrate, product, article, aerosol, air, delivery, flow, direct, channel, passage, path, heat, thermal, dissipation, sink, exchange, cooling, fin, fins, rip, slidably, two, three, multiple, segment, part, portion, support, spacer, filter, acetate, tube, hollow, air, apace, metal, alloy, paper and related terms

C. DOCUMENTS CONSIDERED TO BE RELEVANT

Category*	Citation of document, with indication, where appropriate, of the relevant passages	Relevant to claim No.
X	WO 2020/213143 A1 (JAPAN TOBACCO INC) 22 October 2020 & US 2022/0030936 A1 Figure 1, paragraphs [0033]-[0039] of the patent family member	15-18
X	WO 2020/128045 A1 (PHILIP MORRIS PRODUCTS SA) 25 June 2020 Figure 1, page 23, line 26-page 24, line 9	19-21
X	WO 2020/239597 A1 (PHILIP MORRIS PRODUCTS SA) 3 December 2020 Figure 1, page 36, line 13-page 37, line 20, page 46, line 30-page 47, line 8	19-21
X	US 2019/0069597 A1 (MIRONOV, O.) 7 March 2019 Figure 1, paragraphs [0184]-[0193]	19-21

☒ Further documents are listed in the continuation of Box C.

☒ See patent family annex.

***Special categories of cited documents:**

"A" document defining the general state of the art which is not considered to be of particular relevance

"D" document cited by the applicant in the international application

"E" earlier application or patent but published on or after the international filing date

"L" document which may throw doubts on priority claim(s) or which is cited to establish the publication date of another citation or other special reason (as specified)

"O" document referring to an oral disclosure, use, exhibition or other means

"P" document published prior to the international filing date but later than the priority date claimed

"T" later document published after the international filing date or priority date and not in conflict with the application but cited to understand the principle or theory underlying the invention

"X" document of particular relevance; the claimed invention cannot be considered novel or cannot be considered to involve an inventive step when the document is taken alone

"Y" document of particular relevance; the claimed invention cannot be considered to involve an inventive step when the document is combined with one or more other such documents, such combination being obvious to a person skilled in the art

"&" document member of the same patent family

Date of the actual completion of the international search

07/07/2022

(day/month/year)

Date of mailing of the international search report

08/07/2022

(day/month/year)

Name and mailing address of the ISA/SG

Intellectual Property Office of Singapore
 1 Paya Lebar Link, #11-03
 PLQ 1, Paya Lebar Quarter
 Singapore 408533

Email: pct@ipos.gov.sg

Authorized officer

Chan Mei Yin (Dr)

IPOS Customer Service Tel. No.: (+65) 6339 8616

INTERNATIONAL SEARCH REPORT

International application No.

PCT/SG2022/050164**C (Continuation). DOCUMENTS CONSIDERED TO BE RELEVANT**

Category*	Citation of document, with indication, where appropriate, of the relevant passages	Relevant to claim No.
A	US 2020/0163384 A1 (ROSSOLL, A. M. ET AL.) 28 May 2020 Figures 3-5, paragraphs [0018], [0103]-[0119]	1-9
A	US 2020/0397054 A1 (RIVA, R. R. ET AL.) 24 December 2020 Whole document	
A	US 2015/0136154 A1 (MITREV, P. ET AL.) 21 May 2015 Whole document	

INTERNATIONAL SEARCH REPORT

International application No.

PCT/SG2022/050164

Box No. II Observations where certain claims were found unsearchable (Continuation of item 2 of first sheet)

This international search report has not been established in respect of certain claims under Article 17(2)(a) for the following reasons:

1. Claims Nos.:

because they relate to subject matter not required to be searched by this Authority, namely:

2. Claims Nos.:

because they relate to parts of the international application that do not comply with the prescribed requirements to such an extent that no meaningful international search can be carried out, specifically:

3. Claims Nos.:

because they are dependent claims and are not drafted in accordance with the second and third sentences of Rule 6.4(a).

Box No. III Observations where unity of invention is lacking (Continuation of item 3 of first sheet)

This International Searching Authority found multiple inventions in this international application, as follows:

Please refer to Supplemental Box (Continuation of Box No. III).

1. As all required additional search fees were timely paid by the applicant, this international search report covers all searchable claims.

2. As all searchable claims could be searched without effort justifying additional fees, this Authority did not invite payment of additional fees.

3. As only some of the required additional search fees were timely paid by the applicant, this international search report covers only those claims for which fees were paid, specifically claims Nos.:
1-9 and 15-21

4. No required additional search fees were timely paid by the applicant. Consequently, this international search report is restricted to the invention first mentioned in the claims; it is covered by claims Nos.:

Remark on Protest The additional search fees were accompanied by the applicant's protest and, where applicable, the payment of a protest fee.
 The additional search fees were accompanied by the applicant's protest but the applicable protest fee was not paid within the time limit specified in the invitation.
 No protest accompanied the payment of additional search fees.

INTERNATIONAL SEARCH REPORT
Information on patent family members

International application No.

PCT/SG2022/050164

Note: This Annex lists known patent family members relating to the patent documents cited in this International Search Report. This Authority is in no way liable for these particulars which are merely given for the purpose of information.

Patent document cited in search report	Publication date	Patent family member(s)	Publication date
WO 2020/213143 A1	22/10/2020	US 2022/0030936 A1 KR 20210151193 A EP 3957199 A1 CN 113710108 A	03/02/2022 13/12/2021 23/02/2022 26/11/2021
WO 2020/128045 A1	25/06/2020	EP 3752013 A1 US 2022/0015414 A1 CN 113163853 A PH 12021550874 A1 JP 2020114205 A JP 2022514750 A BR 112021010712 A2 CA 3116957 A1 AU 2019408541 A1 KR 20210107039 A	23/12/2020 20/01/2022 23/07/2021 18/10/2021 30/07/2020 15/02/2022 31/08/2021 25/06/2020 13/05/2021 31/08/2021
WO 2020/239597 A1	03/12/2020	CN 113993397 A EP 3975758 A1 KR 20220011620 A AU 2020281604 A1 CA 3132105 A1	28/01/2022 06/04/2022 28/01/2022 23/09/2021 03/12/2020
US 2019/0069597 A1	07/03/2019	PT 2814345 T ES 2583168 T3 JP 2019050818 A NZ 626016 A KR 20140131318 A CA 2862573 A1 ZA 201404169 B US 2015/0013697 A1 RU 2014137153 A HU E029955 T2 IL 233393 A AU 2017248474 A1 PH 12014501279 A1 DK 2814345 T3 CN 110786562 A AU 2013220525 A1 BR 112014017614 B1 RS 54800 B1 HK 1200662 A1 PL 2814345 T3 AR 089983 A1 SG 11201404189P A MX 2014009760 A TW 201340892 A TW 201336438 A UA 113536 C2 WO 2013/120854 A1 MY 167675 A	07/07/2016 19/09/2016 04/04/2019 24/04/2015 12/11/2014 22/08/2013 29/06/2016 15/01/2015 10/04/2016 28/04/2017 31/03/2020 02/11/2017 08/09/2014 04/07/2016 14/02/2020 18/09/2014 06/10/2020 31/10/2016 14/08/2015 30/11/2016 01/10/2014 30/10/2014 14/11/2014 16/10/2013 16/09/2013 10/02/2017 22/08/2013 21/09/2018

INTERNATIONAL SEARCH REPORT
Information on patent family members

International application No.

PCT/SG2022/050164

Note: This Annex lists known patent family members relating to the patent documents cited in this International Search Report. This Authority is in no way liable for these particulars which are merely given for the purpose of information.

Patent document cited in search report	Publication date	Patent family member(s)	Publication date
		CN 110786561 A AU 2019204519 A1 JP 2015509709 A EP 2814345 A1 CN 104080359 A	14/02/2020 18/07/2019 02/04/2015 24/12/2014 01/10/2014
US 2020/0163384 A1	28/05/2020	WO 2018/220558 A1 RU 2019135673 A KR 20200013648 A PH 12019502181 A1 BR 112019022669 A2 JP 2020521439 A AR 111974 A1 EP 3629782 A1 TW 201902372 A CN 110621175 A	06/12/2018 30/06/2021 07/02/2020 08/06/2020 19/05/2020 27/07/2020 04/09/2019 08/04/2020 16/01/2019 27/12/2019
US 2020/0397054 A1	24/12/2020	CN 111386054 A RU 2020119162 A WO 2019/115464 A1 JP 2021506237 A BR 112020009511 A2 EP 3723525 A1 KR 20200096760 A	07/07/2020 13/01/2022 20/06/2019 22/02/2021 03/11/2020 21/10/2020 13/08/2020
US 2015/0136154 A1	21/05/2015	US 2022/0125099 A1 WO 2013/190036 A1 ZA 201409125 B CN 104754964 A RS 55802 B1 HK 1204234 A1 SI 2863765 T1 KR 20150033617 A EP 2863765 A1 MX 2014015716 A JP 2015519915 A TW 201404320 A LT 2863765 T HU E032677 T2 SG 11201408417U A PL 2863765 T3 PH 12014502765 A1 PT 2863765 T IN 432DEN2015 A CA 2877424 A1 AU 2013279336 A1 RU 2015101642 A AR 091509 A1 ES 2624293 T3 BR 112014031909 A2	28/04/2022 27/12/2013 23/12/2015 01/07/2015 31/08/2017 13/11/2015 26/04/2017 01/04/2015 29/04/2015 05/08/2015 16/07/2015 01/02/2014 10/04/2017 30/10/2017 29/01/2015 31/08/2017 09/02/2015 31/03/2017 19/06/2015 27/12/2013 05/02/2015 10/08/2016 11/02/2015 13/07/2017 27/06/2017

INTERNATIONAL SEARCH REPORT
Information on patent family members

International application No.

PCT/SG2022/050164

Note: This Annex lists known patent family members relating to the patent documents cited in this International Search Report. This Authority is in no way liable for these particulars which are merely given for the purpose of information.

Patent document cited in search report	Publication date	Patent family member(s)	Publication date
		DK 2863765 T3 UA 114725 C2 NZ 703753 A IL 236193 A	08/05/2017 25/07/2017 25/11/2016 30/09/2020

Supplemental Box
(Continuation of Box No. III)

This International Searching Authority found multiple inventions in this international application, as follows:

- Group 1: Claims 1-9, which relates to a heating device for heating an aerosol generating substrate comprising a substrate holder for receiving the aerosol generating substrate and a suction portion comprising a heat dissipation element and is shaped to be slidably received in the heating device.
- Group 2: Claims 10-14, which relates to an aerosol generating product comprising an aerosol generating substrate for use with a heating device.
- Group 3: Claims 15-21, which relates to an aerosol generating product comprising an aerosol generating segment, a support segment and a filter segment.

Please refer to **Box No. IV** of Written Opinion of The International Searching Authority (Form PCT/ISA/237) for detailed explanation.