



- (51) **International Patent Classification:**
H04L 12/24 (2006.01)
- (21) **International Application Number:**
PCT/EP2016/061635
- (22) **International Filing Date:**
24 May 2016 (24.05.2016)
- (25) **Filing Language:** English
- (26) **Publication Language:** English
- (71) **Applicant:** NOKIA SOLUTIONS AND NETWORKS OY [FI/FI]; Karaportti 3, 02610 Espoo (FI).
- (72) **Inventors:** RENNER, Olaf; Freystraße 6, 80802 Munich (DE). HOFFMANN, Klaus; Franz-Sperr-Weg 51, 80995 Munich (DE).
- (81) **Designated States** (unless otherwise indicated, for every kind of national protection available): AE, AG, AL, AM,

AO, AT, AU, AZ, BA, BB, BG, BH, BN, BR, BW, BY, BZ, CA, CH, CL, CN, CO, CR, CU, CZ, DE, DK, DM, DO, DZ, EC, EE, EG, ES, FI, GB, GD, GE, GH, GM, GT, HN, HR, HU, ID, IL, IN, IR, IS, JP, KE, KG, KN, KP, KR, KZ, LA, LC, LK, LR, LS, LU, LY, MA, MD, ME, MG, MK, MN, MW, MX, MY, MZ, NA, NG, NI, NO, NZ, OM, PA, PE, PG, PH, PL, PT, QA, RO, RS, RU, RW, SA, SC, SD, SE, SG, SK, SL, SM, ST, SV, SY, TH, TJ, TM, TN, TR, TT, TZ, UA, UG, US, UZ, VC, VN, ZA, ZM, ZW.

- (84) **Designated States** (unless otherwise indicated, for every kind of regional protection available): ARIPO (BW, GH, GM, KE, LR, LS, MW, MZ, NA, RW, SD, SL, ST, SZ, TZ, UG, ZM, ZW), Eurasian (AM, AZ, BY, KG, KZ, RU, TJ, TM), European (AL, AT, BE, BG, CH, CY, CZ, DE, DK, EE, ES, FI, FR, GB, GR, HR, HU, IE, IS, IT, LT, LU, LV, MC, MK, MT, NL, NO, PL, PT, RO, RS, SE, SI, SK, SM, TR), OAPI (BF, BJ, CF, CG, CI, CM, GA, GN, GQ, GW, KM, ML, MR, NE, SN, TD, TG).

(54) **Title:** INSTANTIATION IN VIRTUALIZED NETWORKS

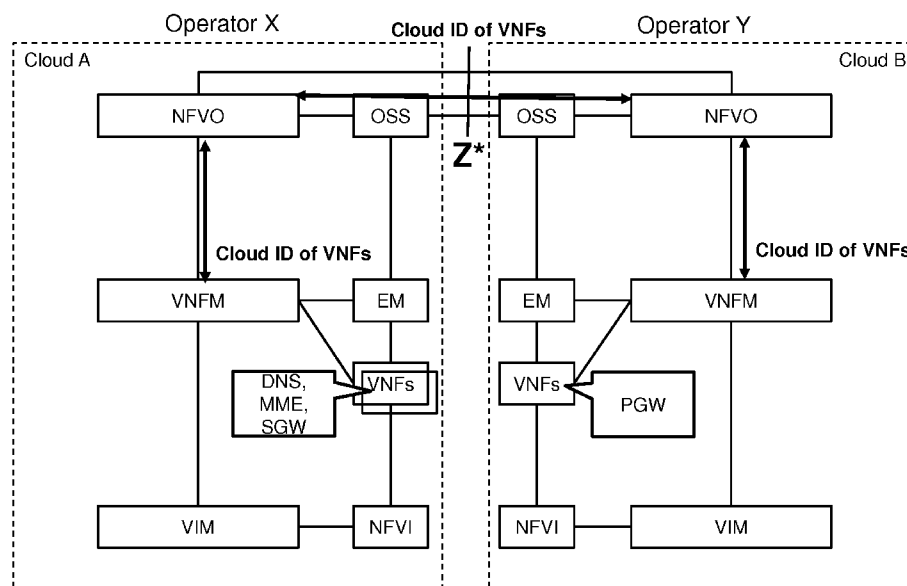

Fig. 4

(57) **Abstract:** It is provided a method, comprising monitoring if a service requires a function, wherein a service host hosts the service; identifying plural function hosts, wherein each of the function hosts is known to host a respective instance of the function; determining for each of the identified function hosts in how far a property of a respective connection between the service host and the respective function host fulfills a requirement, and the determining is based on received connection property indications for the connections, wherein each connection property indication indicates the property of the respective connection; selecting a selected function host out of the plural function hosts, wherein the property of the connection to the selected function host matches the requirement best among the plural connections; requesting the function from the selected function host.



Published:

— *with international search report (Art. 21(3))*

Instantiation in virtualized networks

Field of the invention

The present invention relates to an apparatus, a method, and a computer program product related to network virtualization. More particularly, the present invention relates to an apparatus, a method, and a computer program product related to instantiation in virtualized networks.

Abbreviations

3GPP	3 rd Generation Partnership Project
ALTO	Application layer Traffic Optimisation
GloD	Global Cloud ID
IGP	Interior Gateway Protocol
OSPF	Open Shortest Path First
PID	Provider-Defined Identifier
IMS	IP Multimedia Subsystem
NFV	Network Function Virtualization
NS	Network Service
NFVO	NFV Orchestrator
VNF	Virtual Network Function
VNFM	VNF Manager
VNFFG	VNF Forwarding Graph
MANO	Management and Orchestration
SGW	Serving Gateway
PGW	PDN (Packet Data Network) Gateway
MME	Mobility Management Entity
DNS	Domain Name Server
EM	Element Manager
OSS/BSS	Operations / Business Support System
BGP	Boarder Gateway Protocol
IGP	Interior Gateway Protocol
IBCF	Interconnection Border Control Function
OSPF	Open Shortest Path First
IS-IS	Intermediate System to Intermediate System Protocol

PCE	Path Computation Element
PCEP	Path Computation Element Protocol
ITU	International Telecommunication Union
ITU-T	ITU Telecommunication Standardization
ETSI	European Telecommunications Standards Institute
TS	Technical Specification
QoS	Quality of Service
SLA	Service Level Agreement
ID	Identifier
IP	Internet Protocol
RFC	Request for Comments
EPC	Evolved packet Core
HSS	Home Subscriber Server
CSCF	Call Session Control Function
S-CSCF	Serving CSCF
I-CSCF	Interrogating CSCF
SIP	Session Initiation Protocol
AS	Application Server
CC	Country Code
LAC	Local Area Code
OSI	Open Systems Interconnection
MAC	Medium Access Control

Background of the invention

ETSI GS NFV-MAN 001 V1.1.1 [http://www.etsi.org/deliver/etsi_gs/NFV-MAN/001_099/001/01.01.01_60/gs_nfv-man001v010101p.pdf] describes the management and orchestration of Telco networks in a network function virtualisation environment. The agreed architecture is shown in Fig. 1.

NFV decouples software implementations of Network Functions from the computation, storage, and networking resources they use. The virtualisation insulates the Network Functions from those resources through a virtualisation layer. The Network Functions Virtualisation Management and Orchestration (NFV-MANO) architectural framework has the role to manage the NFVI and orchestrate the allocation of resources needed by the NSs (Network Service) and VNFs. The Network Service Orchestration performs its services by

using the VNF Management services and by orchestrating the NFV Infrastructure that supports the interconnection between VNFs functionality, and its functions are exposed in an open, well known abstracted manner as services to other functions.

Some main functions of the entities shown in Fig. 1 are as follows:

The NFV Orchestrator has two main responsibilities:

- the orchestration of NFVI resources across multiple VIMs, fulfilling the Resource Orchestration functions;
- the lifecycle management of Network Services, fulfilling the Network Service Orchestration functions.

The VNF Manager is responsible for the lifecycle management of VNF instances.

The Virtualised Infrastructure Manager (VIM) is responsible for controlling and managing the NFVI compute, storage and network resources.

The NS Catalogue represents the repository of all of the on-boarded Network Services.

The VNF Catalogue represents the repository of all of the on-boarded VNF Packages.

The NFV Instances repository holds information of all VNF instances and Network Service instances.

The NFVI Resources repository holds information about available/reserved/allocated NFVI resources as abstracted by the VIM across operator's Infrastructure Domains, thus supporting information useful for resources reservation, allocation and monitoring purposes.

The NFVI encompasses all the hardware (e.g. compute, storage, and networking) and software (e.g. hypervisors) components that together provide the infrastructure resources where VNFs are deployed.

A service may consume a function. However, since the function might consume another function, the former function acts as a service, too. Therefore, unless otherwise noted or made clear from the context, the terms "function" and "service" are used synonymously throughout the present application. Also, the terms "cloud", "data center", and "cloud center" are used synonymously unless otherwise noted or made clear from the context.

A connection between two entities may comprise one or more links, wherein a link is a direct connection from one entity to another one without intermediate entities (nodes). The connection may comprise plural paths, wherein each path may comprise one or more links.

Currently it is planned to apply this architecture to the 3GPP environment in a first step. However, current framework description is restricted to a scenario with a single service provider.

In ETSI GS NFV-EVE 005, a requirement recommendation REC#18 is formulated to address proximity of available resources, delay and in REC#17 to enable low latency traffic.

3GPP architecture is described in detail in 3GPP TS 23.401.

Summary of the invention

It is an object of the present invention to improve the prior art.

According to a first aspect of the invention, there is provided an apparatus, comprising monitoring means adapted to monitor if a service requires a function, wherein a service host hosts the service; identifying means adapted to identify, if the service requires the function, plural function hosts, wherein each of the function hosts is known to host a respective instance of the function; determining means adapted to determine for each of the identified function hosts in how far a property of a respective connection between the service host and the respective function host fulfills a requirement, wherein the requirement is predetermined or set by the service, and the determining is based on received connection property indications for the connections, wherein each connection property indication indicates the property of the respective connection; selecting means adapted to select a selected function host out of the plural function hosts, wherein at least one of the following conditions is fulfilled: the property of the connection to the selected function host fulfills the requirement; and the property of the connection to the selected function host matches the requirement best among the plural connections; requesting means adapted to request the function from the selected function host.

The selecting means may be adapted to select the selected function host such that the selected function host is the same as the service host.

According to a second aspect of the invention, there is provided an apparatus, comprising monitoring means adapted to monitor if a service requires a function, wherein a function host hosts the function; identifying means adapted to identify, if the service requires the function, plural service hosts, wherein each of the service hosts is known to host a respective instance of the service; determining means adapted to determine for each of the identified service hosts in how far a property of a respective connection between the respective service host and the function host fulfills a requirement, wherein the requirement is predetermined or set by the service, and the determining is based on received connection property indications for the connections, wherein each connection property indication indicates the property of the respective connection; selecting means adapted to select a selected service host out of the plural service hosts, wherein at least one of the following conditions is fulfilled: the property of the connection from the selected service host fulfills the requirement; and the property of the connection from the selected service host matches the requirement best among the plural connections; locating means adapted to locate the service on the selected service host.

The selecting means may be adapted to select the selected service host such that the selected service host is the same as the function host.

According to each of the first and second aspects, the apparatus may further comprise inquiring means adapted to inquire the connection property indications from a traffic optimization server.

According to the first aspect, the apparatus may further comprise providing means adapted to provide an identifier of the service host and an identifier of the respective function host to the traffic optimization server when inquiring the connection property indication for the connection between the service host and the respective function host.

According to the second aspect, the apparatus may further comprise providing means adapted to provide an identifier of the respective service host and an identifier of the function host to the traffic optimization server when inquiring the connection property indication for the connection between the respective service host and the function host.

According to each of the first and second aspects, the property may be at least one of a physical distance between the service host and the respective function host, a delay on the

respective connection, a jitter on the respective connection, an availability of the respective connection, and a packet loss on the respective connection.

According to a third aspect of the invention, there is provided an apparatus, comprising monitoring means adapted to monitor if an inquiry for a connection property indication of a connection is received, wherein the inquiry comprises a first identification related to a first host and a second identification related to a second host, the connection is between the first host and the second host, and the connection property indication indicates a property of the connection; providing means adapted to provide, in response to the inquiry, the connection property indication.

At least one of the first identification and the second identification may be a respective higher layer address of a protocol on a layer higher than the physical layer, and the apparatus may further comprise converting means adapted to convert the at least one higher layer address into a respective host identification of the respective host on the physical layer; retrieving means adapted to retrieve the connection property indication based on the host identification of the first host and the host identification of the second host.

The higher layer address may be of an address of an internet protocol or of an ethernet protocol.

The property may be at least one of a physical distance between the first host and the second host, a delay on the connection, a jitter on the connection, an availability of the connection, and a packet loss on the connection.

According to a fourth aspect of the invention, there is provided an apparatus, comprising monitoring circuitry configured to monitor if a service requires a function, wherein a service host hosts the service; identifying circuitry configured to identify, if the service requires the function, plural function hosts, wherein each of the function hosts is known to host a respective instance of the function; determining circuitry configured to determine for each of the identified function hosts in how far a property of a respective connection between the service host and the respective function host fulfills a requirement, wherein the requirement is predetermined or set by the service, and the determining is based on received connection property indications for the connections, wherein each connection property indication indicates the property of the respective connection; selecting circuitry configured to select a selected function host out of the plural function hosts, wherein at least one of the following

conditions is fulfilled: the property of the connection to the selected function host fulfills the requirement; and the property of the connection to the selected function host matches the requirement best among the plural connections; requesting circuitry configured to request the function from the selected function host.

The selecting circuitry may be configured to select the selected function host such that the selected function host is the same as the service host.

According to a fifth aspect of the invention, there is provided an apparatus, comprising monitoring circuitry configured to monitor if a service requires a function, wherein a function host hosts the function; identifying circuitry configured to identify, if the service requires the function, plural service hosts, wherein each of the service hosts is known to host a respective instance of the service; determining circuitry configured to determine for each of the identified service hosts in how far a property of a respective connection between the respective service host and the function host fulfills a requirement, wherein the requirement is predetermined or set by the service, and the determining is based on received connection property indications for the connections, wherein each connection property indication indicates the property of the respective connection; selecting circuitry configured to select a selected service host out of the plural service hosts, wherein at least one of the following conditions is fulfilled: the property of the connection from the selected service host fulfills the requirement; and the property of the connection from the selected service host matches the requirement best among the plural connections; locating circuitry configured to locate the service on the selected service host.

The selecting circuitry may be configured to select the selected service host such that the selected service host is the same as the function host.

According to each of the fourth and fifth aspects, the apparatus may further comprise inquiring circuitry configured to inquire the connection property indications from a traffic optimization server.

According to the fourth aspect, the apparatus may further comprise providing circuitry configured to provide an identifier of the service host and an identifier of the respective function host to the traffic optimization server when inquiring the connection property indication for the connection between the service host and the respective function host.

According to the fifth aspect, the apparatus may further comprise providing circuitry configured to provide an identifier of the respective service host and an identifier of the function host to the traffic optimization server when inquiring the connection property indication for the connection between the respective service host and the function host.

According to each of the fourth and fifth aspects, the property may be at least one of a physical distance between the service host and the respective function host, a delay on the respective connection, a jitter on the respective connection, an availability of the respective connection, and a packet loss on the respective connection.

According to a sixth aspect of the invention, there is provided an apparatus, comprising monitoring circuitry configured to monitor if an inquiry for a connection property indication of a connection is received, wherein the inquiry comprises a first identification related to a first host and a second identification related to a second host, the connection is between the first host and the second host, and the connection property indication indicates a property of the connection; providing circuitry configured to provide, in response to the inquiry, the connection property indication.

At least one of the first identification and the second identification may be a respective higher layer address of a protocol on a layer higher than the physical layer, and the apparatus may further comprise converting circuitry configured to convert the at least one higher layer address into a respective host identification of the respective host on the physical layer; retrieving circuitry configured to retrieve the connection property indication based on the host identification of the first host and the host identification of the second host.

The higher layer address may be an address of an internet protocol or of an ethernet protocol.

The property may be at least one of a physical distance between the first host and the second host, a delay on the connection, a jitter on the connection, an availability of the connection, and a packet loss on the connection.

According to a seventh aspect of the invention, there is provided a method, comprising monitoring if a service requires a function, wherein a service host hosts the service; identifying, if the service requires the function, plural function hosts, wherein each of the function hosts is known to host a respective instance of the function; determining for each of

the identified function hosts in how far a property of a respective connection between the service host and the respective function host fulfills a requirement, wherein the requirement is predetermined or set by the service, and the determining is based on received connection property indications for the connections, wherein each connection property indication indicates the property of the respective connection; selecting a selected function host out of the plural function hosts, wherein at least one of the following conditions is fulfilled: the property of the connection to the selected function host fulfills the requirement; and the property of the connection to the selected function host matches the requirement best among the plural connections; requesting the function from the selected function host.

The selecting of the selected function host may be performed such that the selected function host is the same as the service host.

According to an eighth aspect of the invention, there is provided a method, comprising monitoring if a service requires a function, wherein a function host hosts the function; identifying, if the service requires the function, plural service hosts, wherein each of the service hosts is known to host a respective instance of the service; determining for each of the identified service hosts in how far a property of a respective connection between the respective service host and the function host fulfills a requirement, wherein the requirement is predetermined or set by the service, and the determining is based on received connection property indications for the connections, wherein each connection property indication indicates the property of the respective connection; selecting a selected service host out of the plural service hosts, wherein at least one of the following conditions is fulfilled: the property of the connection from the selected service host fulfills the requirement; and the property of the connection from the selected service host matches the requirement best among the plural connections; locating the service on the selected service host.

The selecting of the selected service host may be performed such that the selected service host is the same as the function host.

The method according to any of the seventh and eighth aspects may further comprise inquiring the connection property indications from a traffic optimization server.

The method of the seventh aspect may further comprise providing an identifier of the service host and an identifier of the respective function host to the traffic optimization server when

inquiring the connection property indication for the connection between the service host and the respective function host.

The method of the eighth aspect may further comprise providing an identifier of the respective service host and an identifier of the function host to the traffic optimization server when inquiring the connection property indication for the connection between the respective service host and the function host.

In the method according to each of the seventh and eighth aspects, the property may be at least one of a physical distance between the service host and the respective function host, a delay on the respective connection, a jitter on the respective connection, an availability of the respective connection, and a packet loss on the respective connection.

According to a ninth aspect of the invention, there is provided a method, comprising monitoring if an inquiry for a connection property indication of a connection is received, wherein the inquiry comprises a first identification related to a first host and a second identification related to a second host, the connection is between the first host and the second host, and the connection property indication indicates a property of the connection; providing, in response to the inquiry, the connection property indication.

At least one of the first identification and the second identification may be a respective higher layer address of a protocol on a layer higher than the physical layer, and the method may further comprise converting the at least one higher layer address into a respective host identification of the respective host on the physical layer; retrieving the connection property indication based on the host identification of the first host and the host identification of the second host.

The higher layer address may be an address of an internet protocol or of an ethernet protocol.

The property may be at least one of a physical distance between the first host and the second host, a delay on the connection, a jitter on the connection, an availability of the connection, and a packet loss on the connection.

Each of the methods of the seventh to ninth aspects may be a method of instantiation in virtualized networks.

According to a tenth aspect of the invention, there is provided an apparatus comprising at least one processor, at least one memory including computer program code, and the at least one processor, with the at least one memory and the computer program code, being arranged to cause the apparatus to at least perform at least one of the methods according to the seventh to ninth aspects.

According to an eleventh aspect of the invention, there is provided a computer program product comprising a set of instructions which, when executed on an apparatus, is configured to cause the apparatus to carry out the method according to any of the seventh to ninth aspects. The computer program product may be embodied as a computer-readable medium or directly loadable into a computer.

According to some example embodiments of the invention, at least one of the following technical effects may be provided:

- providing services in a carrier-grade (e.g. including delay) manner even with NFV;
- Reduced load on connections between data centers;
- Increased effectiveness in roaming scenarios.

Brief description of the drawings

Further details, features, objects, and advantages are apparent from the following detailed description of example embodiments of the present invention which is to be taken in conjunction with the appended drawings, wherein

Fig.1 shows a network function virtualization environment according to ETSI GS NFV-MAN 001 V1.1.1;

Fig. 2 shows a basic ALTO architecture according to RFC 7285

Fig. 3 shows a network function virtualization environment with two operators;

Fig. 4 shows a network function virtualization environment with two operators according to an embodiment of the invention related to EPC (Evolved Packet Core);

Fig. 5 show a message flow for S-CSCF selection procedure according to an embodiment of the invention;

Fig. 6 shows a message flow for AS selection procedure according to an embodiment of the invention;

Fig. 7 shows an apparatus according to an example embodiment of the invention;

Fig. 8 shows a method according to an example embodiment of the invention;
Fig. 9 shows an apparatus according to an example embodiment of the invention;
Fig. 10 shows a method according to an example embodiment of the invention;
Fig. 11 shows an apparatus according to an example embodiment of the invention;
Fig. 12 shows a method according to an example embodiment of the invention; and
Fig. 13 shows an apparatus according to an example embodiment of the invention.

Detailed description of certain example embodiments

Herein below, certain example embodiments of the present invention are described in detail with reference to the accompanying drawings, wherein the features of the example embodiments can be freely combined with each other unless otherwise described. However, it is to be expressly understood that the description of certain embodiments is given for by way of example only, and that it is by no way intended to be understood as limiting the invention to the disclosed details.

Moreover, it is to be understood that the apparatus is configured to perform the corresponding method, although in some cases only the apparatus or only the method are described.

In the currently planned steps of applying NFV architecture, roaming is not considered yet. This results in some problems:

For instance, in case the MME of an operator X needs to select the PGW of the operator Y, the MME not only need to know the pure existence of the PGWs owned by the Operator Y, but the MME should also select the “best” PGW even in case of NFV. Since the SGW of the Operator X and the PGW of the Operator Y may or may not be hosted on the same cloud (without knowledge thereof to the applications), the MME is not able to select SGW and PGW in a carrier grade manner, i.e. in a deterministic manner in order to meet certain QoS requirements as expected within legacy networks already.

Today, with the DNS procedure defined in 3GPP TS 29.303, it is possible to sort the pairs of SGW/PGW according to an increasing/decreasing order. However, this mechanism is very very static as the location of the PGW and the SGW are per definition fixed. That means there is no means in place which allows to selectively recognize and select those pairs of gateways which serves the need of a particular delay such as 10 ms delay, or 5 ms delay, or 20 ms

delay, or 50 ms delay. That is, today the delay cannot be quantified/expressed for traffic engineering when selecting SGW/PGW pairs as requested for the service in question.

Network virtualization will allow fast and dynamical placement of network functions globally. As an example, a case is considered where, due to a mass event in South America (e.g. soccer/football), temporarily a very huge number of Asian subscribers travel to South America (or vice versa) to attend the World championship games. In that case it would be much more efficient to select for these Asian subscribers a PGW placed in South America than arbitrarily selecting the PGW located in Asia. Note that the PGW belongs to the home network of the subscriber.

For user experience of Asians in South America it is beneficial to have a PGW in South America, however for the Asian operator it is very costly to operate a "traditional" PGW (on dedicated hardware) in South America. As such there is a trade off when it becomes attractive (increasing number of subscribers in South America) for the operator to instantiate a PGW in South America only in case of mass events instead of operating it all the time in South America without having permanently a significant number of roaming subscribers justifying the instantiation and operation.

Other examples, where the traditional mechanisms have to be adapted for network virtualisation in case of roaming are service chaining where service functions should be selected that are close to the PGW, or a service chain spanning different operators, wherein the delay between the functions should be minimized.

Some embodiments of the invention remedy one or more of these deficiencies.

According to some embodiments of the invention, a respective Global Cloud ID (GloD) is assigned to each cloud (data center).

In some embodiments of the invention,

- a) at least one of the MANO NFV Orchestrator interfaces Vi-Vnfm, Or-Vnfm, Or-Vi, and OS-Ma-nfvo is enabled to forward this information element such that the remote service provider gets this information about the Global Cloud ID for the VNF being instantiated locally; and/or
- b) the MANO VNF Manager interfaces Ve-Vnfm-em and/or Ve-Vnfm-vnf are enabled to forward this information element to the EM and/or to the VNF being

instantiated such that the locally instantiated VNF or the related EM gets this information to know its own Global Cloud ID.

Since the service providers has knowledge about the Global Cloud ID of the remote partner service provider, this information may be taken into account when a particular virtualized network function is to be selected by the service provider.

For instance, if a MME of a service provider X selects or may select a certain SGW being hosted in the cloud center A, a PGW of the provider Y shall be selected which is also hosted by the cloud center A (if available). This is an example where the distance between SGW and PGW is minimized based on the GloD.

In an extension according to some embodiments of the invention, e.g. the MME of the provider X consults a specialized ALTO server with the input parameters of global cloud Ids (for source and one or more destinations, e.g. for the source SGW and the possible PGWs), and the ALTO server returns a list of IP addresses with corresponding latency between the source (e.g. SGW) and the possible destinations (e.g. PGW). Then, the PGW selection process (e.g. at the MME) selects that PGW which is hosted by the cloud center which matches best the latency requirement of the requested service, for instance minimal latency.

Embodiments of the invention are not restricted to minimal latency. Since there are services which require medium latency or higher latency, the PGW may select a PGW which matches the particular latency requirement best (i.e. an absolute delay selection).

Delay (latency) is just an example. Other properties of the connection between the data centers such as the jitter, availability of the connection, and a packet loss on the connection may be handled in the same way. The first two attributes are examples for QoS and SLA requirements.

“Matching best” means that a difference of the requirement (e.g. required latency) and the provided property (latency in this case) is minimized. Here, the term “difference” may mean an absolute value of the arithmetic difference between the property and the provided property, but it may also include other ways to express how much the provided property is different from the requirement. E.g., in some embodiments, “matching best” means that the ratio of the requirement and the property is closest to 1 among the connections, or that the logarithm of this ratio is closest to 0.

The requirements may be set by the service, or they may be predefined. The selection function (such as a PGW selection function) may always (i.e. as a predefined requirement) select the PGW function located at the same data center as the SGW, but if an appropriate PGW function of the home operator is not implemented on that data center, it may select a PGW according to one or more of the requirements set by the service.

TS 29.303 allows today only to infer some closeness in the sense: something is closer than something different, but it does not provide absolute latency values.

The Global Cloud ID is used to get the for instance global delay between the Clouds and, therefore, between the VNF in those clouds.

Furthermore, according to some embodiments, the IGP (interior gateway protocols) like IS-IS, OSPF and other routing protocols like e.g. BGP are augmented with means to carry the Global Cloud ID as well. In these embodiments, each of the data centers may inject the Global Cloud ID, as part of a new PID (Provider-Defined Identifier) together with its corresponding IP addresses to the ALTO server.

Today, the IGP (like the OSPF) already carries the IP Addresses and the metrics like the "delay". Adding the Global Cloud ID would allow to get notion about delay at ALTO server. ("The information distributed using OSPF TE Metric Extensions can then be used to make path selection decisions based on network performance."). This is specified in RFC7471 "OSPF Traffic Engineering (TE) Metric Extensions" available at <http://tools.ietf.org/html/rfc7471>.

For instance average delay of a connection is captured in chapter 4.1. Min and Max covered in chapter 4.2. OSPF is a routing protocol. The ALTO server is specified in "ALTO Protocol" available at <http://tools.ietf.org/html/rfc7285>. According to chapter 3.1 and Figure 1 thereof, the e.g. augmented OSPF shall inject the corresponding information into the ALTO server.

Currently, the interface to the ALTO server is going to be specified in "ALTO Protocol" available at <http://tools.ietf.org/html/rfc7285>. According to chapter 11.2.3.6 thereof, the "cost Map" provides the path cost for each Source PID (Provider-defined Identifier) and Destination PID.

The invention is not restricted to the ALTO protocol. Other protocols such as DNS are feasible to carry information on a connection property such as path costs, too, if accordingly adapted.

Based on the figure 1 of RFC7285 for instance, e.g. the MME may act as an ALTO client connected to the ALTO server (potentially being operated by a Third Party). Furthermore, the different Cloud Operators are participating in the routing protocol level (OSPF, IS-IS, etc) to inject their corresponding Global Cloud IDs and corresponding correlated IP Addresses. As such the ALTO Server is enabled to have a global view of the Cloud connectivity.

Alternatively, also the PCE and PCEP may be used instead or in addition (if some of the functionality is split) to the ALTO server.

The usage of the ALTO server/ PCE is an optimized generalized solution of the scenario described in the beginning, namely that e.g. a MME can identify the SGW and PGW to be selected such that they reside on the same cloud.

The indications of connection properties (such as latency, jitter, etc.) provided by the ALTO server may be administered thereon. That is, these values may reflect some average value (or some minimum value or some maximum value, depending on the specific property and the implementation) of the respective property which was obtained beforehand. Thus, the indicated connection property may be different from the actual connection property.

In some embodiments, ALTO server may request from time to time or event-based (e.g. if the property indication is requested) to determine the actual value of the property. However, if such a determination is performed when the property indication is requested it may result in unacceptable long delays for the response to the request. Therefore, this option is typically not preferred.

The Global Cloud ID allows engineering the selection process in a carrier grade way, such that "same cloud" is only one of a lot of requirements each of which may be put on the connection between datacenters on which a service and a function consumed by the service reside.

The above description is just an example. There may be other information elements, which may be exchanged between the different service providers.

After the selection process (i.e. of a SGW and PGW based on e.g. latency information) an operator may decide to move a virtualized network function to another location (e.g. due to policy, service requirements, business needs, or whatever reasons). In this case the original latency requirement may or may not be met anymore for the established relationship between service and its consumed function. (However, for any newly received request for setting up an EPC Session, the actual Global Cloud ID is updated and the actual location is taken into account for a selection).

According to some embodiments of the invention, latency between possibly candidate peers for the initial selection is known. Thus, in case of a service relocation, the same selection process may run again in order to decide if another function instantiation is to be selected.

Consequently, if the original selection process is notified about the fact of the relocation (e.g. by recognizing the new Global Cloud ID) it shall check whether the original requirement for the latency is still met. If it is still met there is no need to act. However, if latency was increased beyond or below the QoS limit, the (re)-selection process may try to initiate relocation of the local instance in accordance with operators business needs, policy rules and/or service requirements of the subscribers, or may terminate the service.

E.g. for best effort services the operator may not want to act, however for premium users the operator may wish to re-locate.

Fig. 3 shows an example for a roaming scenario in a NFV environment, where the operator Y hosts at least one PGW and the operator X hosts at least one MME/SGW. Each of operators X and Y may be a "real" operator or a "virtual" operator which does not operate a network but uses one or more networks operated by (a) "real" operator(s). Each of operators X and Y may provide an end-to-end service.

According to some embodiments, the global Cloud ID is allocated/reported by the VNFM and sent to the NFVO through the VNFM via Or-Vnfm. The exact entity assigning the CloudID may depend on implementation and may be different from VNFM (e.g. it can be assigned by some entity of a cloud management system like OpenStack).

The CloudID of VNFs is then exchanged through interface Z* across multiple sites and can be complemented with ALTO latency information between VNFs to help the selection process of multi-site service VNFs.

A flow sequence according to some embodiments is described below with reference to Fig. 4.

During VNF instantiation (NFVO – VNFM) the Global cloud ID is assigned and stored in NFVO database along with other VNF information.

Two providers interact via their respective management interface Z*, which shall be also used to carry the GloD of the PGW being instantiated.

Note: There might not be a direct interface between the two separated NFVOs, but an enabled interface between the two OSS/BSS systems, which is summarized here as interface Z*. (In general there are several options of how the Cloud ID may be exchanged: For instance out of band or via a shared database). A multi-site management reference point and interface between OSS-OSS or NFVO-NFVO is currently not specified, but a new work item proposal NFV(16)000059 has been submitted to ETSI NNFV which may be subject to the here mentioned interface Z*.

Furthermore via this interface not only the Cloud ID and the name of the instantiated VNF may be signalled between the two NFVOs, but also the originating and destination Operator (fixed or mobile operator) may be signalled, in particular for a case of a multi-tenant scenario wherein any NFVO (e.g. a third party) may host several different network operators. In that case the one service provider may receive the GloD of a VNF via that interface when needed.

For instance the two operators may have instantiated their own NFV networks independently from each other. However at a later stage they may wish to interwork and need to exchange their mutual EPC network interfaces for successful interworking. As part of this procedure for instance the GloD and the PGW information may be exchanged, e.g. by a query request.

Based on this, in the scenario of Fig. 3, the operator Y (NFVO/OSS/BSS) may inform the DNS/MME about the GloD of the peer PGW, such that the selection process at the MME of operator X shall preferably select a PGW instance of the peer operator, which resides in the same global cloud depending on the needs of the requested service.

For that, in some embodiments, the DNS query and responses is augmented with the GloD so that the S/PGW selection process is able to recognise and evaluate the Global Cloud ID. In some embodiments, the cloud ID is added to the DNS response. Alternatively, MME may issue an additional DNS query which retrieves the Global Cloud ID, but such additional DNS query might not be optimal.

The Global Cloud ID is introduced because in today's processes the location of the PGW and SGW (as well as that of the MME and other NEs) is static. With the introduction of NFV applications, the locations are not static anymore. The Global Cloud ID allows to express the floating location of a SGW and PGW. The Global Cloud ID structure may be mapped to the same structure of the SGW PGW structure as of today (for instance via DNS query), but this does not provide any indication of the delay between NFV instances.

E.g., when a VNF is moved to another cloud, the IP address of the VNF is maintained. This shows that, in virtualized network architectures, the IP address is not related to a location of a physical device any more. Therefore, the IP address does not provide information on the connection between the logical entities. This deficiency is remedied by GloD which is an identifier of the physical layer (1st layer of the OSI model). In contrast to that, the IP address is an identifier on the network layer (3rd layer of the OSI model).

In particular in cases where the Cloud ID is not the same for both SGW and PGW, in some embodiments the ALTO server is consulted for the candidate Global Cloud IDs pairs. Based on operator policies and service requirements the pair with e.g. suitable delay is selected. That is, the ALTO provides an indication of the delay for several pairs of Global Cloud IDs, and MME selects one PGW (the other member of the pair is SGW which cannot be selected) which fulfils the required delay best.

Definition / Authorship of Global cloud ID

Due to global nature of the problem to be solved there is a need for global definition. In today's networks the operators (at least bilaterally) need to agree on the common understanding and presentation of their respective SGW and PGW in their DNS system. As such Operators know the need already. In future due to the dynamicity of networks the "location" needs to be signaled instead of being statically configured.

Of course, there needs to be a registration process. Since there is a need for such an

identifier, processes may be potentially established within ITU-T or 3GPP. For instance the Global Cloud ID could consist of a Country code (CC), where the cloud physically resides and an operator ID (identifying the Operator within that country) and a sub-identifier allocated by the operator in order to differentiate different data centers of the operator. Only those data center operators which want to participate in hosting telco cloud physical network functions and/or VNFs (virtual network functions) may be required to register a Global cloud ID in order to serve the optimized selection of MME, SGW, PGW, HSS , CSCF etc.

In some embodiments, the GloD may be implemented as a “Constraint” in a VNF Descriptor to manage policies as described in 5.4.1 and 5.4.2 of ETSI GS NFV-MAN 001, or it may be stored and queried in an NFVO database, e.g, the VNF catalogue. Further the Global cloud ID may be either implicitly encoded in the DNS response or explicitly in a new parameter.

Example for implicit coding

Today, according to 3GPP TS 29.303, a DNS Entry looks like the following.

```
imsTV1.apn          (
; IN NAPTR order pref. flag service          regexp replacement
  IN NAPTR 100 999 "a" "x-3gpp-pgw:x-s5-gtp:x-s8-gtp"      "" topoff.vip1.gw01.nodes )
  IN NAPTR 200 999 "a" "x-3gpp-pgw:x-s5-gtp:x-s8-gtp"      "" topoff.vip1.gw21.nodes
; IN NAPTR 300 999 "a" "x-3gpp-pgw:x-gn:x-gp"              "" topoff.vip3.gw01.nodes
```

Taking “topoff.vip1.gw01.nodes”, one may code the Cloud ID into it like the following: “topoff.vip1.GICIID001.gw01.nodes”.

I.e., one may define GICIID001 == CC.LAC.ID (Country code, Local Area Code, ID). As an alternative, GloD may have a form like: country.city.datacenter.

Preferably, the form of the GloD is standardized, or (at least) bilaterally or even multilaterally agreed between those players participating in this new service.

As an example for explicit coding GICIID001 == CC.LAC.ID (Country code, Local Area Code, ID) may be specified as another new explicit information element

In some embodiments, the same process may be established as for the Cell ID already in place for the Global cell ID of mobile networks today. For instance, ITU-T or 3GPP may operate a registration service where the Cloud Operator can apply for and register their Global Cloud IDs. This can be done on a registration process which may be based per country (see above) or based on companies.

According to some embodiments, the NFV-MANO system of the operator X is also augmented with the new capability such that the SGW/MME(/DNS) know its own Global Cloud ID. This may be performed in accordance to b) hereinabove. Therefore the selection process has knowledge about the Global Cloud ID of those virtualised network functions in question.

In another embodiment of this invention in order to support the carrier grade functionality, it is suggested that the (SGW and PGW) selection process at the MME is further enhanced and supported by the following additional procedure.

- a) Each Cloud center injects its Global Cloud ID and its relevant IP addresses to the ALTO server for the Global virtualized service. The latency associated with IP addresses are assumed to be carried e.g. via OSPF normally hosted by the router connected to the cloud centers. Or alternatively e.g. the OSPF is augmented with the GloD such that both the latency and the Global Cloud ID is signalled via OSPF (to the ALTO Server).
- b) The MME (when performing the new SGW/PGW selection process in the virtualised network) consults the ALTO server with a query carrying the GloD of the SGWs and the GloD of the PGWs (as received via the NFV-MANO interfaces, which was previously described)
- c) The ALTO server returns the latency between the possible source data centers and destination datacenter for each IP address of the data center.
The MME on receipt of the response from the ALTO server selects the pair of SGW and PGW in those clouds which meets best the requirement of the service (or a predetermined requirement such as "same location").

For instance, for each PGW in its Cloud at the remote service provider there could be returned e.g. up to three or four IP addresses. With the draft „ALTO traffic Engineering Cost Metrics“, the MME will get the „delay“ information to the SGW for each of the IP addresses of a PGW in a particular data center.

Then, if minimum delay is required, the MME may order the PGWs according to their (maximum) delay and select that PGW with the lowest (maximum) delay. Now the PGW in the nearest cloud is selected.

Generally by maintaining a sorted list of GloD, IP addresses and delays this information can be leveraged to select delay optimized VNF forwarding graphs.

In some embodiments, MME may provide IP addresses of potential PGWs to ALTO server. ALTO server may determine the corresponding GloD and then determine the delays as above. It may return the IP addresses and respective delays to MME. This option may be useful in particular if the IP address of PGW with the NS and the IP address of the cloud hosting the NS belong to the same layer.

Thus, even in case of roaming in a fully virtualized network, a deterministic selection process is possible.

The above mentioned SGW/PGW selection process in a virtualised environment is just an example. Other examples may be the MME selection performed by the eNB, or the selection of an incoming IBCF done by the outgoing IBCF in case of IMS.

The IBCF knows its own Global Cloud ID. The IBCF acting as an exit point retrieves the list of potential entry points (e.g. IBCF or I-CSCF) either via DNS (RFC3262) or from local provision. As with previous descriptions, either the DNS response returns the Global Cloud ID for each potential entry point (IBCF or I-CSCF) or the provisioned local configuration returns the Global Cloud ID with each potential entry point (e.g. IBCF or I-CSCF). As with previous descriptions, the exit IBCF consults the ALTO server to retrieve, for instance, the delay (or another connection property) between the own Global Cloud ID and the Global Cloud ID of the list of potential entry points. On receipt of the delay between the pairs of the Global Cloud IDs of the own/exit IBCF and the Global Cloud ID of the entry IBCF/I-CSCF points, the exit IBCF selects the entry point (IBCF/I-CSCF) depending on the connection property requested by the service or on a predetermined connection property.

Some further examples are explained in detail in the following.

IMS (IP Multimedia System) Terminating S-CSCF (Serving - Call Session control Function)
Selection procedure

In another embodiment of this invention in order to support the carrier grade functionality, the terminating S-CSCF selection process at the terminating I-CSCF is further enhanced and supported by the following additional procedure (see Fig. 5, based on a call flow of 3GPP TS 23.228).

As shown in Fig. 5, in this case the originating (calling party) subscriber belongs to operator A, whereas the destination subscriber (called party) belongs to operator B. Since the operator A recognized that the called party does belong to Operator B the IMS call initiation message SIP INVITE is forwarded to the I-CSCF (Interrogating - Call Session Control Function) of the operator B (steps 1 to 3). The I-CSCF task is it to query the HSS for the appropriate terminating S-CSCF to host the SIP session of the B-party via the Cx Interface. In the NFV Environment in addition to the ID of the B-Party the I-CSCF shall provide the ID of the originating S-CSCF to the HSS (Home Subscriber Server) in step 4. To our knowledge today the I-CSCF does not provide the ID of the originating S-CSCF to the HSS and therefore it is written in bold in the figure to highlight that this is a new information element to be sent up to the HSS. The HSS having access to its own list of S-CSCF of Operator B, in turn queries the ALTO server for instance for the delay between the originating S-CSCF of the operator A and the (terminating) S-CSCFs of own Operator B in step 4a. In step 5 the ALTO server provides e.g. the delay between the originating S-CSCF and the terminating S-CSCF candidates. The HSS on receipt of the message 5 selects the S-CSCF based on the delay information (i.e. the pair of I-CSCF and one of the S-CSCF candidates which matches best the required delay), and the call set up continues with step 6 where SIP INVITE is sent via the P-CSCF (Serving - Call Session control Function) towards the B-Party. The remaining steps are the same as conventionally according to 3GPP TS 23.228.

Note 1: Alternatively the origination S-CSCF may have already signalled the Global Cloud ID of the originating S-CSCF to the terminating I-CSCF as an additional SIP information element. Consequently the Global Cloud ID may have been inserted additionally already into the query to the HSS.

Note 2: Alternatively the origination I-CSCF may perform the HSS query and the ALTO interrogation instead of splitting this across the I-CSCF and the HSS.

Note 3: It is to be noted that the Global Cloud ID possibly may be incorporated/coded into the Domain Name the originating S-CSCF instead of having/defining an explicit new information element.

The delay mentioned above is just an example. In general any other attribute like jitter, availability, packet loss, etc. may be subject of the optimisation and selection procedure.

AS (Application Server) selection procedure

In another embodiment of this invention in order to support the carrier grade functionality, it is suggested that the terminating AS selection process at the terminating I-CSCF is further enhanced and supported by the following additional procedure (see Fig. 6, based on another call flow of 3GPP TS 23.228).

As depicted in fig. 6, in this case the originating (calling party) subscriber belongs to operator A, whereas the destination service belongs to operator B. Since the operator A recognized that the called service does belong to Operator B the IMS call initiation message SIP INVITE is forwarded to the I-CSCF (Interrogating - Call Session control Function) of the operator B (step 1). The I-CSCF task is it to query the DNS for the appropriate terminating AS to host the service via the DNS Interface. In the NFV Environment according to some embodiments of the invention, in addition to the ID of the service the I-CSCF provides the ID of the originating S-CSCF to the DNS (Domain Name Service) in step 4. To our knowledge today the I-CSCF does not provide the ID of the originating S-CSCF to the DNS and is therefore written in bold in the figure to highlight that this is a new information element to be sent up to the DNS. The DNS having access to its own list of AS (Application Servers) of Operator B, in turn returns Global Cloud ID to the I-CSCF. On receipt of the list of possible AS with their corresponding Global Cloud ID the I-CSCF queries the ALTO server for instance for the delay between the originating S-CSCF of the operator A and the (terminating) service of own Operator B in step 5a. In step 5b the ALTO server provides e.g. the delay between the originating S-CSCF and the potential terminating application Server (AS) hosting the requested service candidates. The I-CSCF on receipt of the flow 5b selects the AS based on the delay information (Application Server which matches best of the pairs of originating S-CSCF and plural AS) which matches best, and the call set up continues with flow 7 where the SIP INVITE is sent towards the selected AS.

Note 1: Alternatively, the origination S-CSCF may have already signalled the Global Cloud ID of the originating S-CSCF to the terminating I-CSCF as an additional SIP information element.

Note 2: It is to be noted that the Global Cloud ID possibly may be incorporated/coded into the Domain Name the originating S-CSCF instead of having/defining an explicit new information element.

The delay mentioned above is just an example. In general any other attribute like jitter, availability, packet loss, etc. may be subject of the optimisation and selection procedure.

MME selection procedure

It is known that a MME selection procedure at the eNB exists, however it is not explicitly standardised today.

It is suggested that the MME selection procedure takes into account the eNB ID for which the Global Cloud ID is retrieved. In case that the eNB selects the MME, the eNB is provided with the Global Cloud ID via the MANO interface. In case an old MME is selecting the new MME the old MME queries the DNS server at first to get the Global Cloud ID of the eNB in question. In both cases the selection function is aware of the Global Cloud ID of the eNB. In the next step the selection function retrieves from the list of potential MME the Global Cloud ID of the MMEs from the DNS. In the next step the selection function consults the ALTO server with each pair of eNB ID with its corresponding Global Cloud ID and the MME with its Global Cloud IDs to retrieve e.g. the corresponding delay for each pair. On receipt of the response from the ALTO server the MME selection function selects the MME which matches best the delay requirement. Again, delay is only an example requirement.

Fig. 7 shows an apparatus according to an example embodiment of the invention. The apparatus may be a network function such as a MME, or an element thereof. Fig. 8 shows a method according to an example embodiment of the invention. The apparatus according to Fig. 7 may perform the method of Fig. 8 but is not limited to this method. The method of Fig. 8 may be performed by the apparatus of Fig. 7 but is not limited to being performed by this apparatus.

The apparatus comprises monitoring means 10, identifying means 20, determining means 30, selecting means 40, and requesting means 50. The monitoring means 10, identifying means 20, determining means 30, selecting means 40, and requesting means 50 may be a monitoring circuitry, identifying circuitry, determining circuitry, selecting circuitry, and requesting circuitry, respectively.

The monitoring means 10 monitors if a service requires a function, wherein a service host hosts the service (S10). For example, the “function” may be providing network connectivity, which is provided by a PGW and which is requested from a SGW providing the “service”.

If the service requires the function (S10 = “yes”), the identifying means 20 identifies plural function hosts (S20). Each of the function hosts is known to host a respective instance of the function. For example, the plural function hosts may be indicated as hosting the function in a received message.

The determining means 30 determines for each of the identified function hosts in how far a property of a respective connection between the service host and the respective function host fulfills a requirement (S30). The requirement is predetermined or set by the service. The determining S30 by the determining means 30 is based on received connection property indications for the connections. Each connection property indication indicates the property of the respective connection. For example, the property may be at least one of a distance between the service host and the respective function host, a delay on the respective connection, a jitter on the respective connection, an availability of the respective connection, and a packet loss on the respective connection. If the physical distance is 0, the function host and the service host are hosted by the same data center.

The selecting means 40 selects a selected function host out of the plural function hosts (S40). The selected function host is selected such that at least one of the following conditions is fulfilled:

- the property of the connection to the selected function host fulfills the requirement;
and
- the property of the connection to the selected function host matches the requirement best among the plural connections.

The requesting means 50 requests the function from the selected function host (S50).

Fig. 9 shows an apparatus according to an example embodiment of the invention. The apparatus may be a network function such as a MME, or an element thereof. Fig. 10 shows a method according to an example embodiment of the invention. The apparatus according to Fig. 9 may perform the method of Fig. 10 but is not limited to this method. The method of Fig. 10 may be performed by the apparatus of Fig. 9 but is not limited to being performed by this apparatus.

The apparatus comprises monitoring means 210, identifying means 220, determining means 230, selecting means 240, and locating means 250. The monitoring means 210, identifying means 220, determining means 230, selecting means 240, and locating means 250 may be a monitoring circuitry, identifying circuitry, determining circuitry, selecting circuitry, and locating circuitry, respectively.

The monitoring means 210 monitors if a service requires a function, wherein a function host hosts the function (S210). For example, the “function” may be providing network connectivity, which is provided by a PGW and which is requested from a SGW providing the “service”.

If the service requires the function (S210 = “yes”), the identifying means 220 identifies plural service hosts (S220). Each of the service hosts is known to host a respective instance of the service. For example, the plural service hosts may be indicated as hosting the service in a received message.

The determining means 230 determines for each of the identified service hosts in how far a property of a respective connection between the respective service host and the function host fulfills a requirement (S230). The requirement is predetermined or set by the service. The determining S230 by the determining means 230 is based on received connection property indications for the connections. Each connection property indication indicates the property of the respective connection. For example, the property may be at least one of a physical distance between the service host and the respective function host, a delay on the respective connection, a jitter on the respective connection, an availability of the respective connection, and a packet loss on the respective connection. If the physical distance is 0, the function host and the service host are hosted by the same data center.

The selecting means 240 selects a selected service host out of the plural service hosts (S240). The selected service host is selected such that at least one of the following conditions is fulfilled:

- the property of the connection from the selected service host fulfills the requirement; and
- the property of the connection from the selected service host matches the requirement best among the plural connections.

The locating means 250 locates the service on the selected service host (S250).

Fig. 11 shows an apparatus according to an example embodiment of the invention. The apparatus may be an ALTO server, or an element thereof. Fig. 12 shows a method according to an example embodiment of the invention. The apparatus according to Fig. 11 may perform the method of Fig. 12 but is not limited to this method. The method of Fig. 12 may be performed by the apparatus of Fig. 11 but is not limited to being performed by this apparatus.

The apparatus comprises monitoring means 110 and providing means 120. The monitoring means 110 and providing means 120 may be a monitoring circuitry and providing circuitry, respectively.

The monitoring means 110 monitors if an inquiry for a connection property indication of a connection is received (S110). The inquiry comprises a first identification related to a first host and a second identification related to a second host. For example, each of the first and second identifications may be an IP address, or each of the first and second identifications may be a GloD. The connection is between the first host and the second host. The connection property indication indicates a property of the connection. For example, the property is at least one of a distance between the first host and the second host, a delay on the connection, a jitter on the connection, an availability of the connection, and a packet loss on the connection.

The providing means 120 provides, in response to the inquiry, the connection property indication (S120).

Fig. 13 shows an apparatus according to an example embodiment of the invention. The apparatus comprises at least one processor 610, at least one memory 620 including computer program code, and the at least one processor 610, with the at least one memory 620 and the computer program code, being arranged to cause the apparatus to at least perform at least one of the methods according to Figs. 8, 10, and 12 and related description.

Some embodiments of the invention are described where the IP address is mapped to the GloD (identifier of the physical layer). However, according to some embodiments of the invention, instead of or in addition to the IP address another identifier of a layer higher than the physical layer may be mapped to the GloD. For example, such a higher layer identifier may be a MAC address of the Ethernet protocol. Internet protocol (e.g. IPv4, IPv6) and Ethernet protocol are just examples of higher layer protocols.

Some embodiments of the invention are described where an ALTO server provides a connection property. However, the invention is not restricted to an ALTO server. For example, a DNS server may provide the corresponding functionality. Also, another server may provide this functionality. The server may be dedicated to providing this functionality or may provide other functionality, too.

Some embodiments of the invention are described where the MME selects one of several function hosts (e.g. PGWs) based on a connection property while the corresponding service host (e.g. SGW) is fixed. Furthermore, some embodiments of the invention are described where the MME selects one of several service hosts (e.g. SGWs) based on a connection property while the corresponding function host (e.g. PGW) is fixed. In some embodiments of the invention, these selections may be performed iteratively: E.g., for each of plural service hosts, the respective "best matching" function host is determined. Then, the "very best matching" pair among these best matching pairs of service host and function host is selected. Alternatively, for each of plural function hosts, the respective "best matching" service host is determined. Then, the "very best matching" pair among these best matching pairs of service host and function host is selected.

One piece of information may be transmitted in one or plural messages from one entity to another entity. Each of these messages may comprise further (different) pieces of information.

Names of network elements, protocols, and methods are based on current standards. In other versions or other technologies, the names of these network elements and/or protocols and/or methods may be different, as long as they provide a corresponding functionality.

If not otherwise stated or otherwise made clear from the context, the statement that two entities are different means that they perform different functions. It does not necessarily mean that they are based on different hardware. That is, each of the entities described in the

present description may be based on a different hardware, or some or all of the entities may be based on the same hardware. It does not necessarily mean that they are based on different software. That is, each of the entities described in the present description may be based on different software, or some or all of the entities may be based on the same software. Embodiments of the invention may be employed fully or partly in the cloud, wherein a resource (e.g. processor, software, memory, network) for the respective task may be shared with other applications.

According to the above description, it should thus be apparent that example embodiments of the present invention provide, for example a virtualized network function, a datacenter running the virtualized network function, or a component thereof, an apparatus embodying the same, a method for controlling and/or operating the same, and computer program(s) controlling and/or operating the same as well as mediums carrying such computer program(s) and forming computer program product(s). According to the above description, it should thus be apparent that example embodiments of the present invention provide, for example a traffic optimization server such as a ALTO server or a corresponding function, or a component thereof, an apparatus embodying the same, a method for controlling and/or operating the same, and computer program(s) controlling and/or operating the same as well as mediums carrying such computer program(s) and forming computer program product(s).

Implementations of any of the above described blocks, apparatuses, systems, techniques, means, entities, units, devices, or methods include, as non-limiting examples, implementations as hardware, software, firmware, special purpose circuits or logic, general purpose hardware or controller or other computing devices, a virtual machine, or some combination thereof.

It should be noted that the description of the embodiments is given by way of example only and that various modifications may be made without departing from the scope of the invention as defined by the appended claims.

Claims:

1. Apparatus, comprising

monitoring means adapted to monitor if a service requires a function, wherein a service host hosts the service;

identifying means adapted to identify, if the service requires the function, plural function hosts, wherein each of the function hosts is known to host a respective instance of the function;

determining means adapted to determine for each of the identified function hosts in how far a property of a respective connection between the service host and the respective function host fulfills a requirement, wherein the requirement is predetermined or set by the service, and the determining is based on received connection property indications for the connections, wherein each connection property indication indicates the property of the respective connection;

selecting means adapted to select a selected function host out of the plural function hosts, wherein at least one of the following conditions is fulfilled:

- the property of the connection to the selected function host fulfills the requirement;
- and
- the property of the connection to the selected function host matches the requirement best among the plural connections;

requesting means adapted to request the function from the selected function host.

2. The apparatus according to claim 1, wherein the selecting means is adapted to select the selected function host such that the selected function host is the same as the service host.

3. Apparatus, comprising

monitoring means adapted to monitor if a service requires a function, wherein a function host hosts the function;

identifying means adapted to identify, if the service requires the function, plural service hosts, wherein each of the service hosts is known to host a respective instance of the service;

determining means adapted to determine for each of the identified service hosts in how far a property of a respective connection between the respective service host and the function host fulfills a requirement, wherein the requirement is predetermined or set by the service, and the determining is based on received connection property indications for the

connections, wherein each connection property indication indicates the property of the respective connection;

selecting means adapted to select a selected service host out of the plural service hosts, wherein at least one of the following conditions is fulfilled:

- the property of the connection from the selected service host fulfills the requirement; and
- the property of the connection from the selected service host matches the requirement best among the plural connections;

locating means adapted to locate the service on the selected service host.

4. The apparatus according to claim 3, wherein the selecting means is adapted to select the selected service host such that the selected service host is the same as the function host.

5. The apparatus according to any of claims 1 to 4, further comprising

inquiring means adapted to inquire the connection property indications from a traffic optimization server.

6. The apparatus according to claim 5, further comprising,

if dependent on any of claims 1 and 2, providing means adapted to provide an identifier of the service host and an identifier of the respective function host to the traffic optimization server when inquiring the connection property indication for the connection between the service host and the respective function host, and,

if dependent on any of claims 3 and 4, providing means adapted to provide an identifier of the respective service host and an identifier of the function host to the traffic optimization server when inquiring the connection property indication for the connection between the respective service host and the function host.

7. The apparatus according to any of claim 1 to 6, wherein the property is at least one of a physical distance between the service host and the respective function host, a delay on the respective connection, a jitter on the respective connection, an availability of the respective connection, and a packet loss on the respective connection.

8. Apparatus, comprising

monitoring means adapted to monitor if an inquiry for a connection property indication of a connection is received, wherein the inquiry comprises a first identification related to a first host and a second identification related to a second host, the connection is between the

first host and the second host, and the connection property indication indicates a property of the connection;

providing means adapted to provide, in response to the inquiry, the connection property indication.

9. The apparatus according to claim 8, wherein at least one of the first identification and the second identification is a respective higher layer address of a protocol on a layer higher than the physical layer, and the apparatus further comprises

converting means adapted to convert the at least one higher layer address into a respective host identification of the respective host on the physical layer;

retrieving means adapted to retrieve the connection property indication based on the host identification of the first host and the host identification of the second host.

10. The apparatus according to claim 9, wherein the higher layer address is an address of an internet protocol or of an ethernet protocol.

11. The apparatus according to any of claims 8 to 10, wherein the property is at least one of a physical distance between the first host and the second host, a delay on the connection, a jitter on the connection, an availability of the connection, and a packet loss on the connection.

12. Method, comprising

monitoring if a service requires a function, wherein a service host hosts the service;

identifying, if the service requires the function, plural function hosts, wherein each of the function hosts is known to host a respective instance of the function;

determining for each of the identified function hosts in how far a property of a respective connection between the service host and the respective function host fulfills a requirement, wherein the requirement is predetermined or set by the service, and the determining is based on received connection property indications for the connections, wherein each connection property indication indicates the property of the respective connection;

selecting a selected function host out of the plural function hosts, wherein at least one of the following conditions is fulfilled:

- the property of the connection to the selected function host fulfills the requirement;
- and

- the property of the connection to the selected function host matches the requirement best among the plural connections;
requesting the function from the selected function host.

13. The method according to claim 12, wherein the selecting of the selected function host is performed such that the selected function host is the same as the service host.

14. Method, comprising

monitoring if a service requires a function, wherein a function host hosts the function;
identifying, if the service requires the function, plural service hosts, wherein each of the service hosts is known to host a respective instance of the service;

determining for each of the identified service hosts in how far a property of a respective connection between the respective service host and the function host fulfills a requirement, wherein the requirement is predetermined or set by the service, and the determining is based on received connection property indications for the connections, wherein each connection property indication indicates the property of the respective connection;

selecting a selected service host out of the plural service hosts, wherein at least one of the following conditions is fulfilled:

- the property of the connection from the selected service host fulfills the requirement; and
- the property of the connection from the selected service host matches the requirement best among the plural connections;

locating the service on the selected service host.

15. The method according to claim 14, wherein the selecting of the selected service host is performed such that the selected service host is the same as the function host.

16. The method according to any of claims 12 to 15, further comprising

inquiring the connection property indications from a traffic optimization server.

17. The method according to claim 16, further comprising,

if dependent on any of claims 12 and 13, providing an identifier of the service host and an identifier of the respective function host to the traffic optimization server when inquiring the connection property indication for the connection between the service host and the respective function host, and,

if dependent on any of claims 14 and 15, providing an identifier of the respective service host and an identifier of the function host to the traffic optimization server when inquiring the connection property indication for the connection between the respective service host and the function host.

18. The method according to any of claim 12 to 17, wherein the property is at least one of a physical distance between the service host and the respective function host, a delay on the respective connection, a jitter on the respective connection, an availability of the respective connection, and a packet loss on the respective connection.

19. Method, comprising

monitoring if an inquiry for a connection property indication of a connection is received, wherein the inquiry comprises a first identification related to a first host and a second identification related to a second host, the connection is between the first host and the second host, and the connection property indication indicates a property of the connection;

providing, in response to the inquiry, the connection property indication.

20. The method according to claim 19, wherein at least one of the first identification and the second identification is a respective higher layer address of a protocol on a layer higher than the physical layer, and the method further comprises

converting the at least one higher layer address into a respective host identification of the respective host on the physical layer;

retrieving the connection property indication based on the host identification of the first host and the host identification of the second host.

21. The method according to claim 20, wherein the higher layer address is an address of an internet protocol or of an ethernet protocol.

22. The method according to any of claims 19 to 21, wherein the property is at least one of a physical distance between the first host and the second host, a delay on the connection, a jitter on the connection, an availability of the connection, and a packet loss on the connection.

23. A computer program product comprising a set of instructions which, when executed on an apparatus, is configured to cause the apparatus to carry out the method according to any of claims 12 to 22.

24. The computer program product according to claim 23, embodied as a computer-readable medium or directly loadable into a computer.

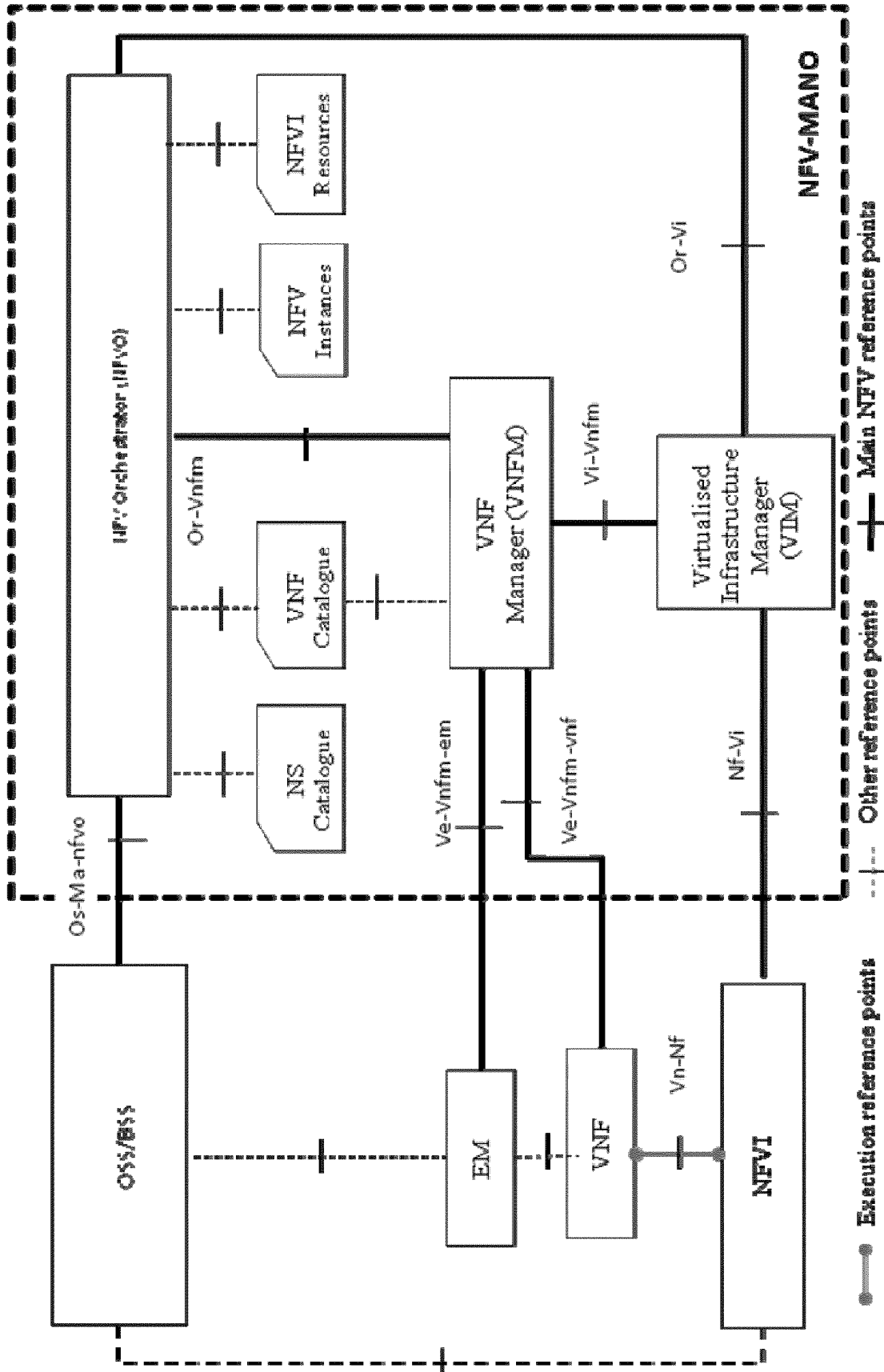

Fig. 1

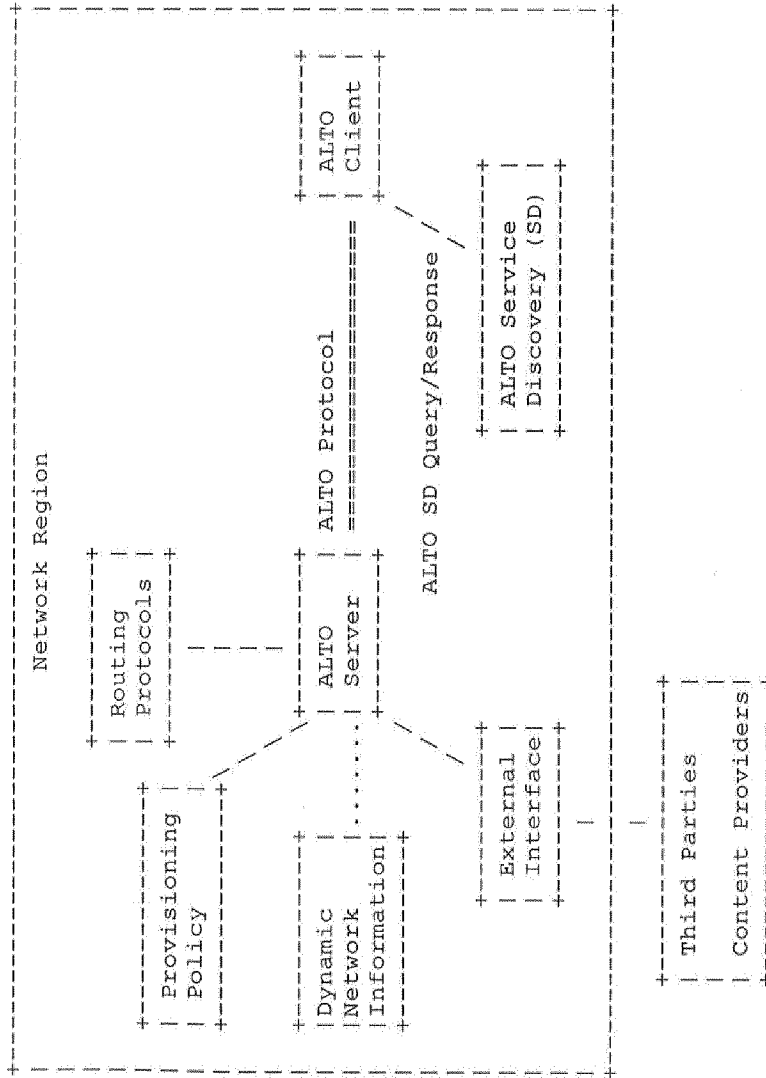

Fig. 2

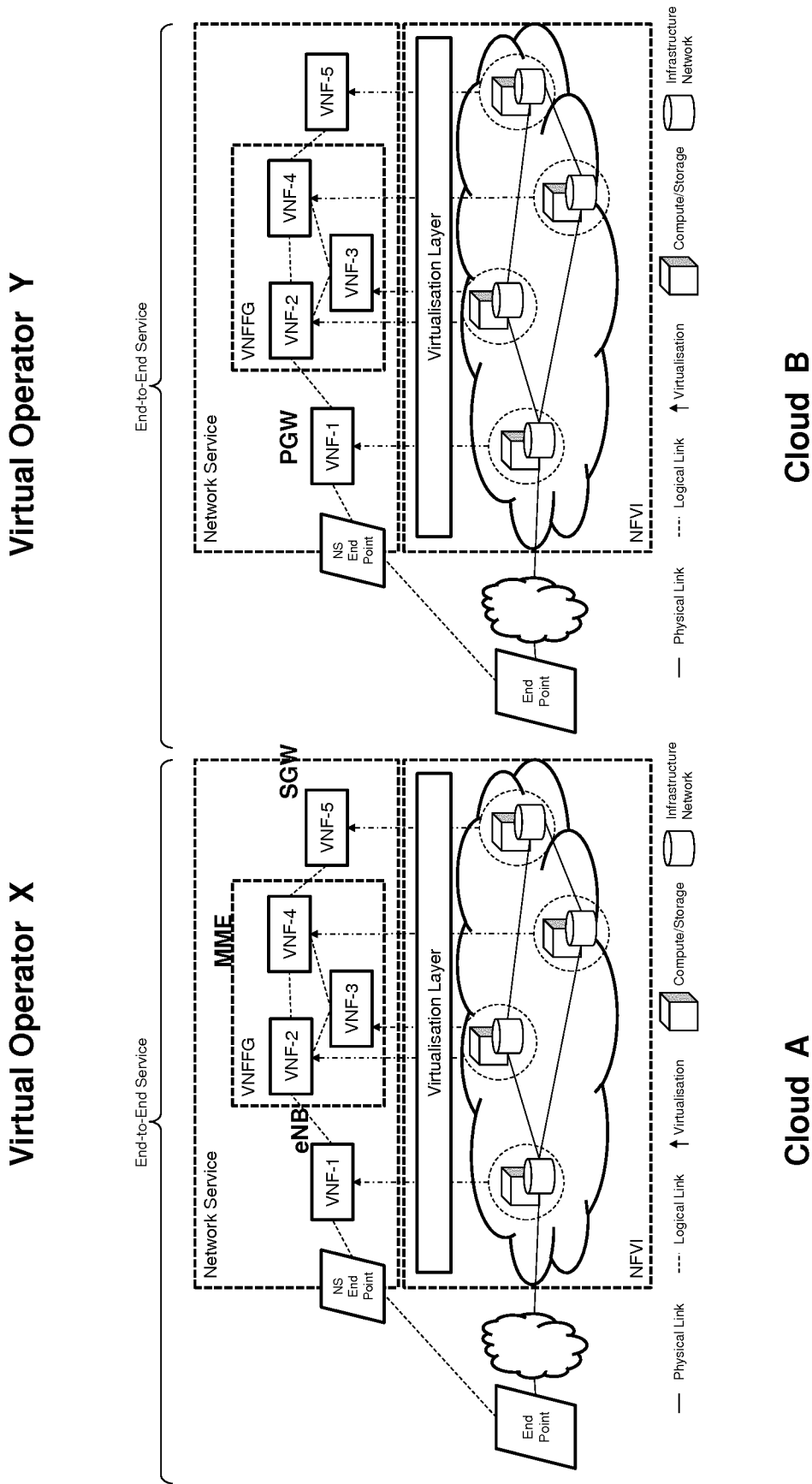

Fig. 3

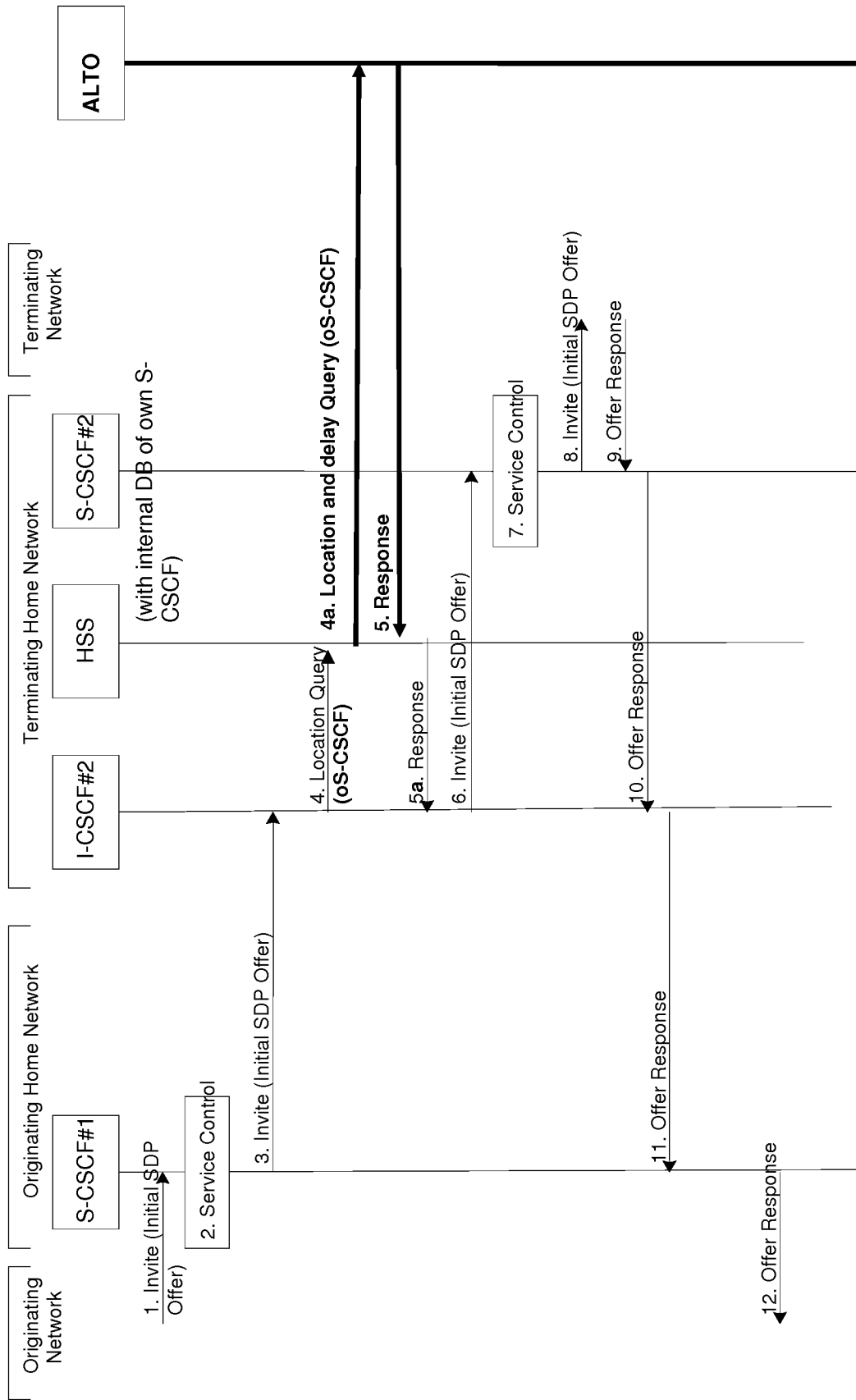

Fig. 5

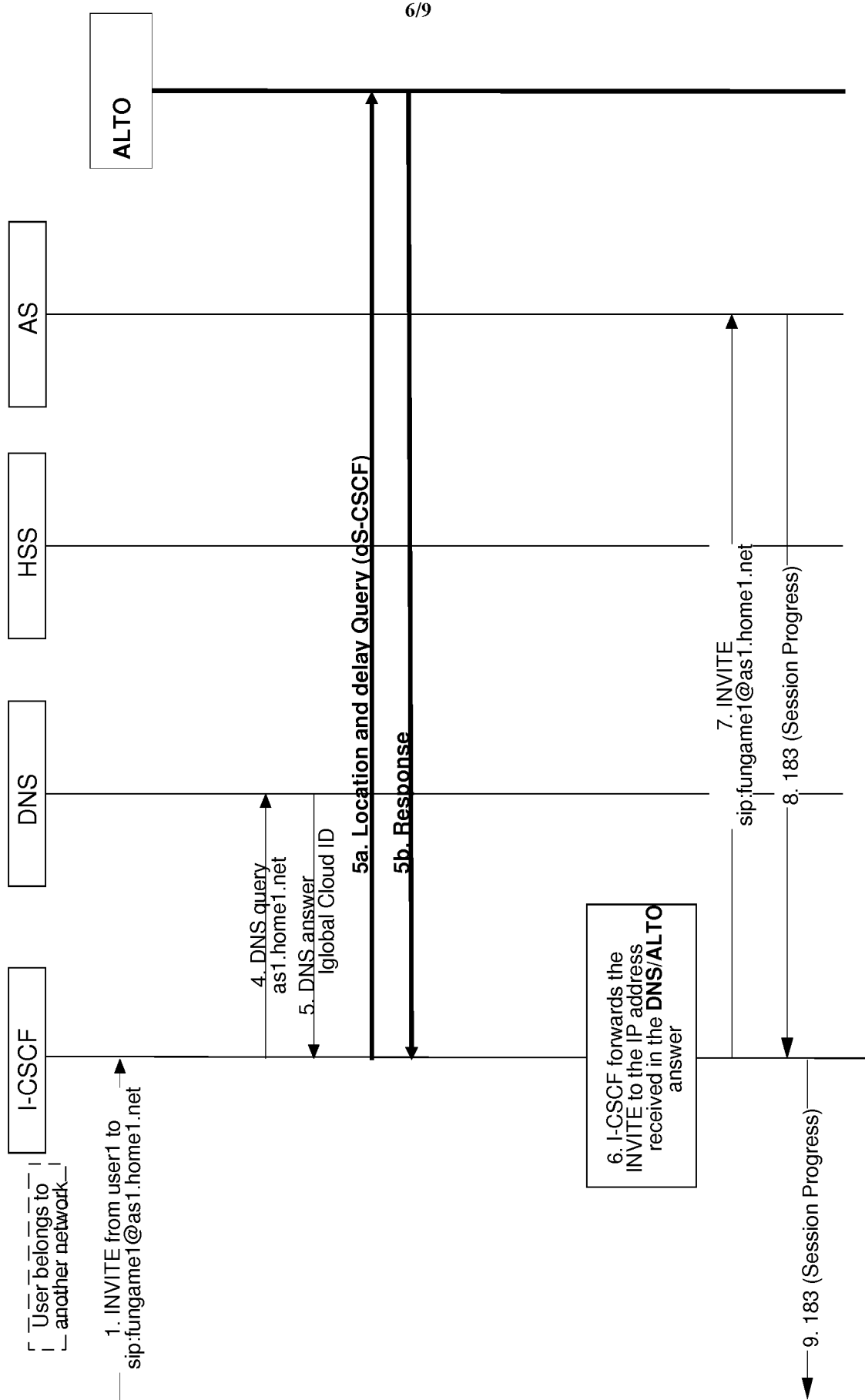

Fig. 6

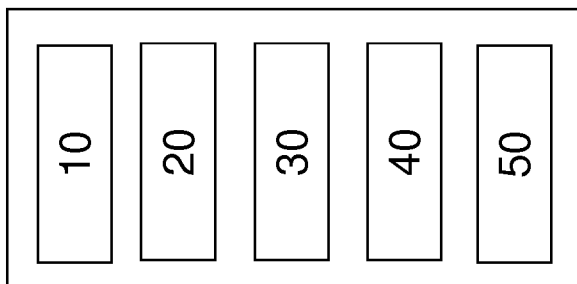

Fig. 7

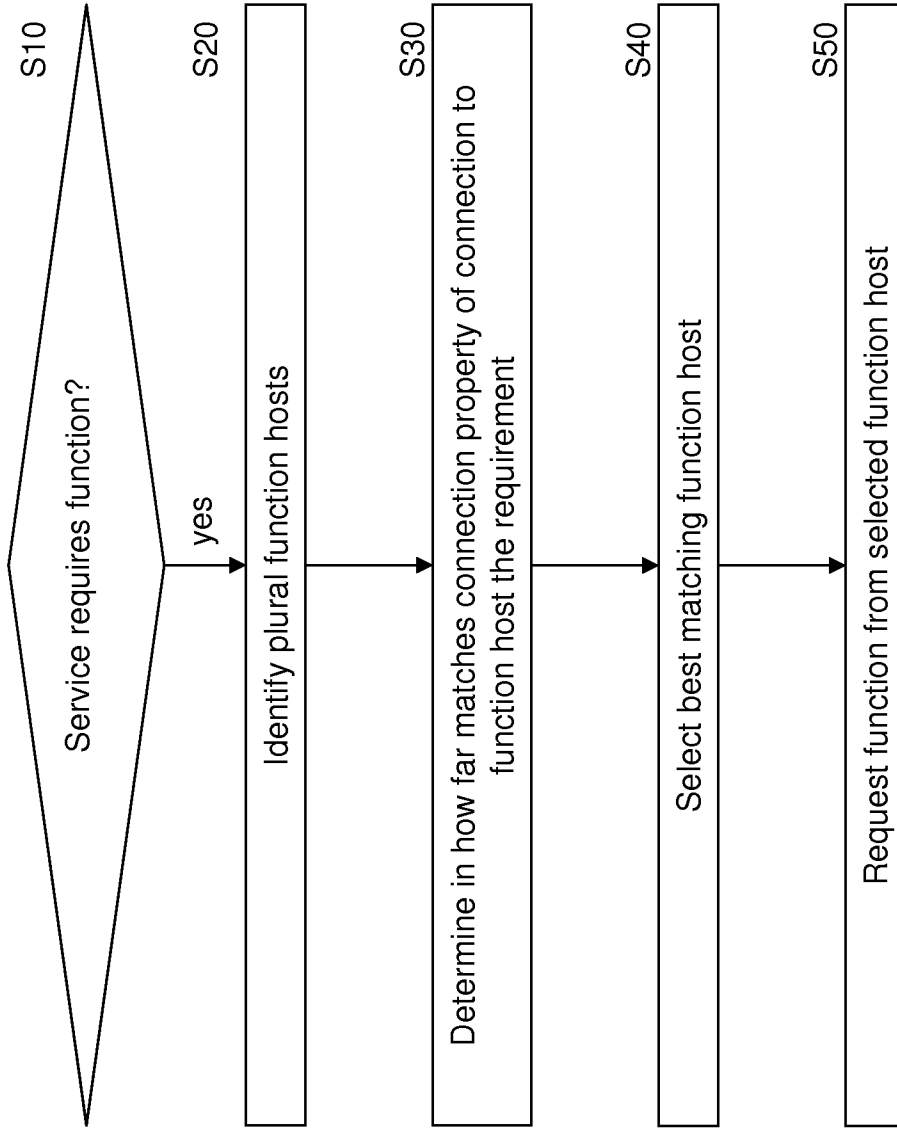

Fig. 8

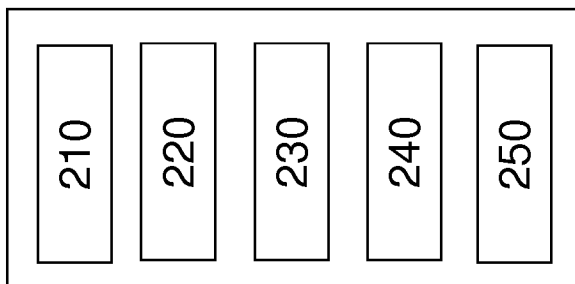

Fig. 9

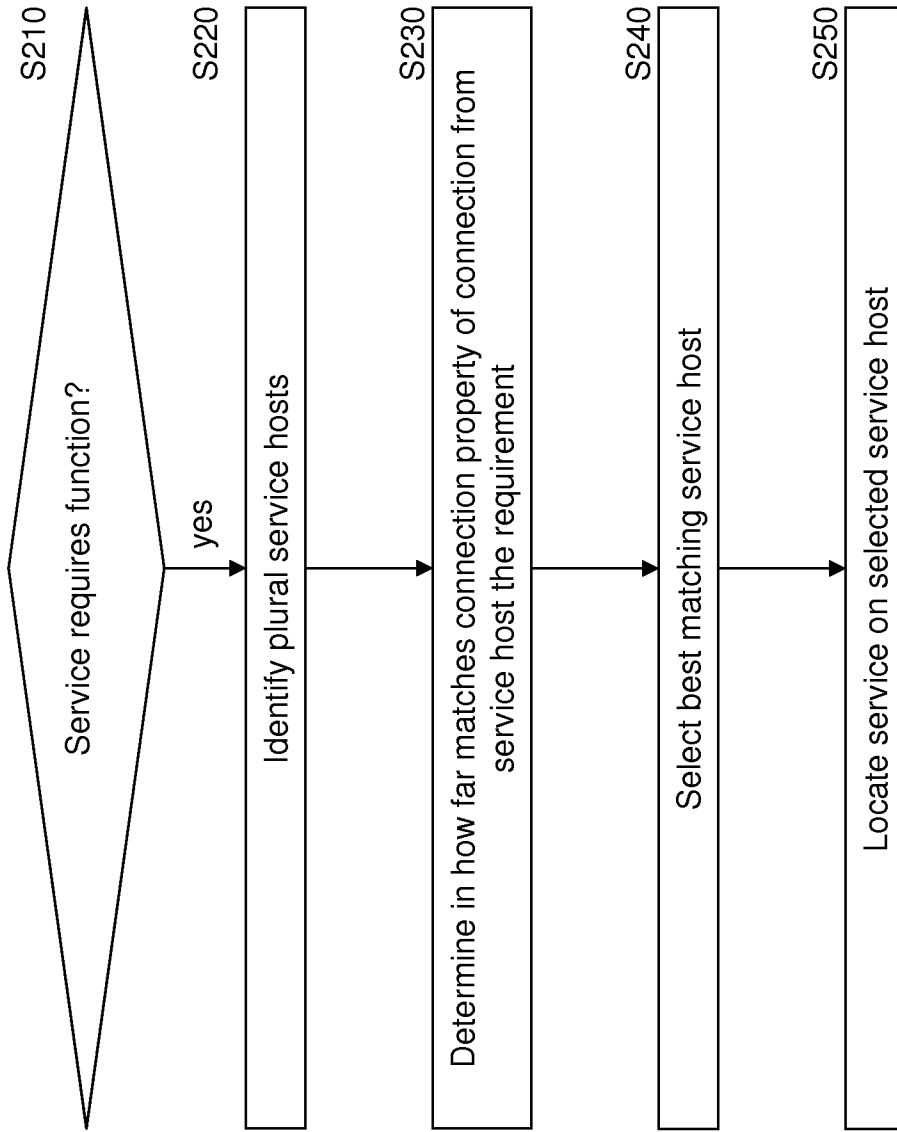

Fig. 10

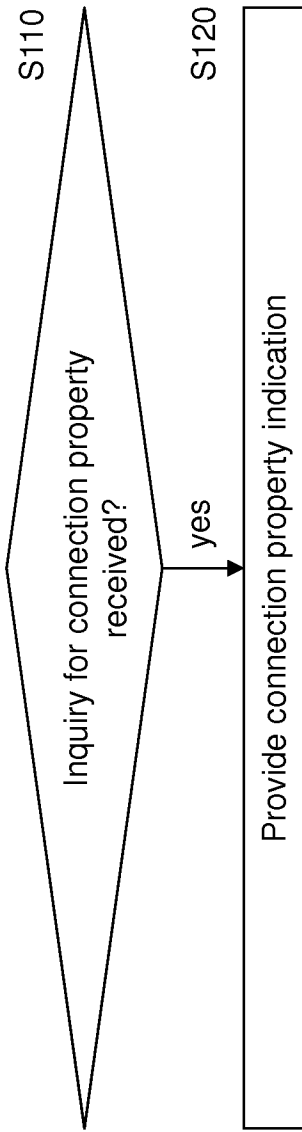

Fig. 12

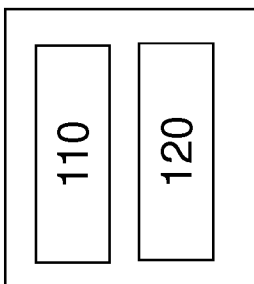

Fig. 11

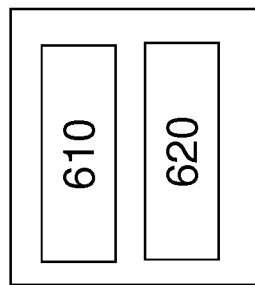

Fig. 13

INTERNATIONAL SEARCH REPORT

International application No
PCT/EP2016/061635

A. CLASSIFICATION OF SUBJECT MATTER
INV. H04L12/24
ADD.
According to International Patent Classification (IPC) or to both national classification and IPC

B. FIELDS SEARCHED
Minimum documentation searched (classification system followed by classification symbols)
H04L
Documentation searched other than minimum documentation to the extent that such documents are included in the fields searched

Electronic data base consulted during the international search (name of data base and, where practicable, search terms used)
EPO-Internal, WPI Data

C. DOCUMENTS CONSIDERED TO BE RELEVANT		
Category*	Citation of document, with indication, where appropriate, of the relevant passages	Relevant to claim No.
X	US 2015/288767 A1 (FARGANO MICHAEL J [US] ET AL) 8 October 2015 (2015-10-08) abstract; figures 1A-11 paragraph [0021] - paragraph [0041] paragraph [0088] - paragraph [0105] -----	1-24
X	WO 2016/071736 A1 (ERICSSON TELEFON AB L M [SE]; QIANG ZU [CA]) 12 May 2016 (2016-05-12) abstract; figures 1-4 page 8, line 9 - page 20, line 10 -----	1-24
A	WO 2015/082013 A1 (NOKIA SOLUTIONS & NETWORKS OY [FI]) 11 June 2015 (2015-06-11) the whole document -----	1-24

Further documents are listed in the continuation of Box C.

See patent family annex.

* Special categories of cited documents :

- "A" document defining the general state of the art which is not considered to be of particular relevance
- "E" earlier application or patent but published on or after the international filing date
- "L" document which may throw doubts on priority claim(s) or which is cited to establish the publication date of another citation or other special reason (as specified)
- "O" document referring to an oral disclosure, use, exhibition or other means
- "P" document published prior to the international filing date but later than the priority date claimed

- "T" later document published after the international filing date or priority date and not in conflict with the application but cited to understand the principle or theory underlying the invention
- "X" document of particular relevance; the claimed invention cannot be considered novel or cannot be considered to involve an inventive step when the document is taken alone
- "Y" document of particular relevance; the claimed invention cannot be considered to involve an inventive step when the document is combined with one or more other such documents, such combination being obvious to a person skilled in the art
- "&" document member of the same patent family

Date of the actual completion of the international search

19 January 2017

Date of mailing of the international search report

03/02/2017

Name and mailing address of the ISA/

European Patent Office, P.B. 5818 Patentlaan 2
NL - 2280 HV Rijswijk
Tel. (+31-70) 340-2040,
Fax: (+31-70) 340-3016

Authorized officer

Plata-Andres, Isabel

INTERNATIONAL SEARCH REPORT

Information on patent family members

International application No

PCT/EP2016/061635

Patent document cited in search report	Publication date	Patent family member(s)	Publication date
US 2015288767 A1	08-10-2015	US 2015288541 A1	08-10-2015
		US 2015288622 A1	08-10-2015
		US 2015288767 A1	08-10-2015

WO 2016071736 A1	12-05-2016	US 2016277509 A1	22-09-2016
		WO 2016071736 A1	12-05-2016

WO 2015082013 A1	11-06-2015	EP 3077907 A1	12-10-2016
		US 2016308715 A1	20-10-2016
		WO 2015082013 A1	11-06-2015
