

Jan. 12, 1971

L. C. HENNESSEY

3,554,600

LEG LOUNGER

Filed Sept. 23, 1968

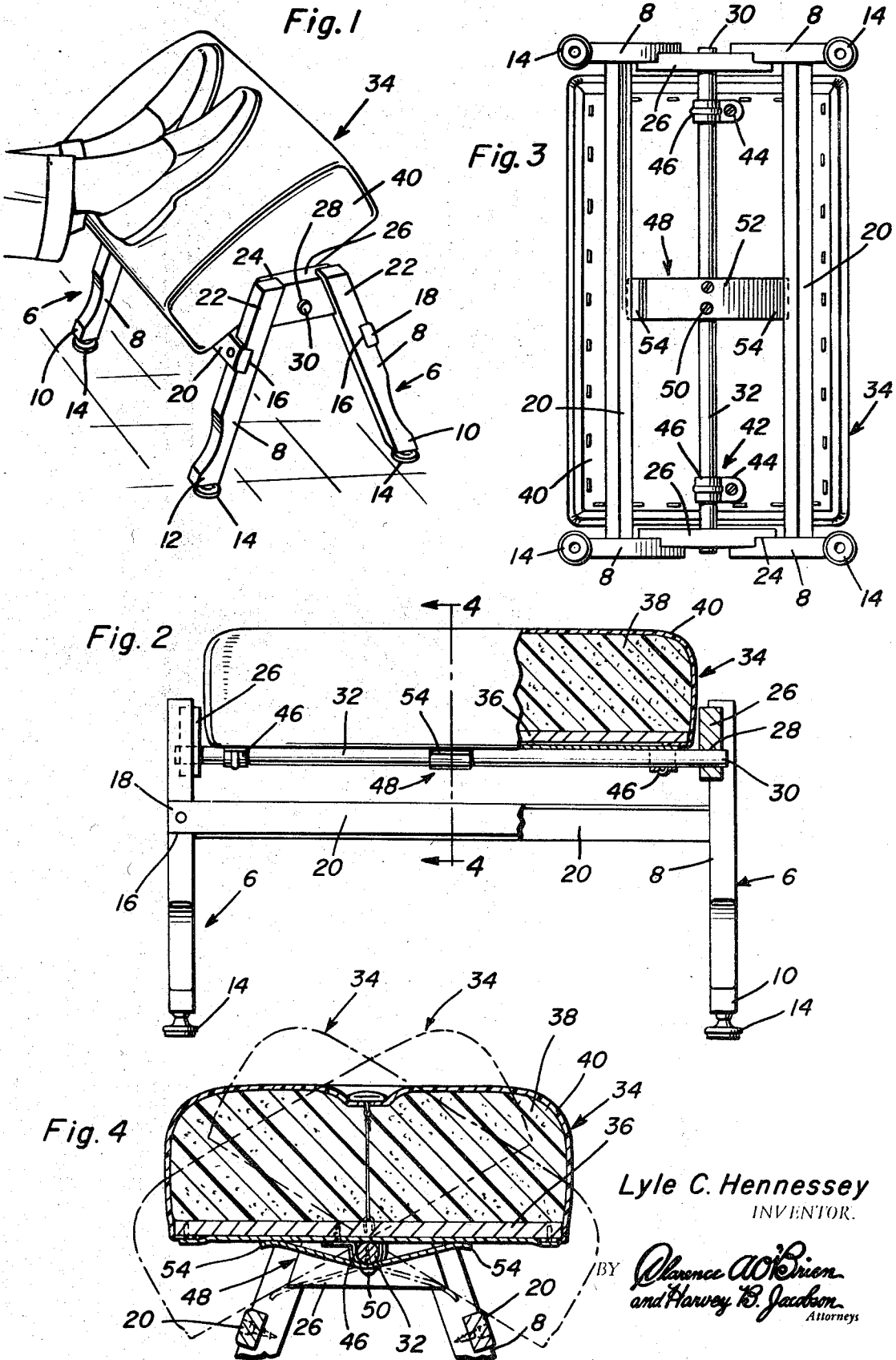

Lyle C. Hennessey
INVENTOR.

BY Clarence W. O'Brien
and Harvey B. Jacobson
Attorneys

1

3,554,600
LEG LOUNGER

Lyle C. Hennessey, 101 Franklin, Waterloo, Iowa 50703

Filed Sept. 23, 1968, Ser. No. 761,413

Int. Cl. A47c 9/12

U.S. Cl. 297-439

2 Claims

ABSTRACT OF THE DISCLOSURE

An upholstered cushion of suitable size and shape provides an ottoman-like foot and leg lounger. It is pivotally and tiltably cradled atop a stand-supported rung. Forward and rearward tilting positions of the cushion are regulated by rigidifying limit stop rails embodied in the stand. A simple spring holds the cushion in a normal horizontal state but permits the cushion to tilt under weight and pressure to a comfortable angularly tilted position.

This invention relates to portable ottomans, foot stools and rests, more particularly, to a leg and foot lounger which features facilities and significant improvements not present in similar prior art loungers.

For background information and to assist the reader in categorizing, generally stated, the field of invention under consideration attention may be directed to a patent to Fuerst, 2,912,046, which has to do with a portable stand supported ottoman and which is characterized by vertical spaced apart leg frames between whose upper portions a padded, upholstered or an equivalent footrest is tiltably mounted. In the stated Fuerst patent, the cushion is shiftable to and adjustably lockable in predetermined tilted or angular leg supporting positions.

An object of the present invention is to provide an adaptation wherein the cushion is hingedly bracketed on a frame supported rung and which is automatically variable in position, is spring-loaded and is responsive to weight and pressure to best assume the comforting angle desired.

Briefly the herein disclosed leg lounger is characterized by a self-supporting stand. This stand, in turn, is characterized by a pair of opposed vertical inverted V-shaped or equivalent end frames. Each end frame comprises a pair of like legs having upwardly converging ends joined by an intervening fixedly mounted head block. The lower diverging ends of the legs are provided with swivelly mounted self-leveling floor-engaging feet or the like. A simple wooden or an equivalent rung of appropriate length is disposed between and spans the space between the head blocks of the end frames and, in fact, has terminal end portions securely joined to central portions of the respective head blocks. Reinforcing and stabilizing rails also span the space between the end frames and have their end portions joined to median notched portions of the respectively cooperable legs. These rails are disposed in a common plane with each other and a plane below the plane of the rung. The foot and leg lounging rest is located in the space between the head blocks and has a plain or covered bottom provided with clips. These clips are attached directly or indirectly to the bottom and have semi-circular stirrup-like portions which are pivotally mounted on end portions of the rung. Spring means is carried by the median part of the rung and serves to maintain the cushion in a normal horizontal position but allows it to tilt forwardly or rearwardly as desired.

These together with other objects and advantages which will become subsequently apparent reside in the details of construction and operation as more fully hereinafter described and claimed, reference being had to the accom-

2

panying drawings forming a part hereof, wherein like numerals refer to like parts throughout, and in which:

FIG. 1 is a view perspective of a foot and leg lounger constructed in accordance with the invention and showing the manner in which it is constructed and used.

FIG. 2 is a view on an enlarged scale with parts in section and elevation and showing the essential component parts.

FIG. 3 is a bottom plan view.

And FIG. 4 is a section taken approximately on the plane of the section line 4-4 of FIG. 2 looking in the direction of the arrows.

Referring now to the views of the drawing, the aforementioned self-supporting, portable stand, which can be made of wood, plastic material or the like comprises a pair of substantially inverted V-shaped end frames (sometimes referred to as A frames) which are identical in construction and are denoted by the numeral 6. Each frame is the same in construction and comprises a pair of duplicate coplanar upwardly converging legs 8. The lower diverging end portions 10 are cut straight across as at 12 and are provided with suitably mounted self-leveling swivelly mounted feet which are also sometimes referred to as coasters 14. The median portions of the outwardly facing edges of the legs are provided with keeper notches 16 to accommodate the seated and suitably secured end portions 18 of a pair of coplanar longitudinal reinforcing rails 20. These rails serve to join the two frames 6 in stand-forming relationship and they are in a common plane and in a plane below the upper ends 22 of the legs. These upper ends converge and are seated in mortises 24 provided in the end portions of suitable connecting head blocks 26. The median portion of each end block is provided with a bearing hole 28 for the coating terminal end portion 30 of the aforementioned horizontal elongated rung 32. The end portions are preferably rigidly secured by adhesive or other material in the holes in which they are fitted and anchored.

The multipurpose foot and leg rest is denoted, generally construed, by the numeral 34 and is in the form of an upholstered cushion. This cushion is of rectangular form and of a size to fit between the respective end frames 6. It is also of a width that the longitudinal edge portions overhang the rails 20 so that the rails have the additional function of providing limit stops. This is to say the overhanging edge portions come to rest against the rails in the manner suggested in phantom lines in FIG. 4. Each rest is characterized by a bottom plate or panel 36. The panel is of requisite size and shape and supports a suitably attached foam rubber or an equivalent cushion or pad 38. The pad is snugly enclosed in a plastic or an equivalent protector jacket 40.

The bottom of the cushion is mounted by end brackets on the rung, each bracket being denoted, generally speaking, by the numeral 42. The bracket comprises an attaching ear 44 secured in place and having a reinforced U-shaped or semi-circular stirrup 46 which embraces the rung to provide the desired attaching and cradling action. Thus the cushion is perched atop the rung and is allowed to pivot and tilt either toward or from the user in the manner shown for example in phantom lines in FIG. 4. Normally this leg rest is in the horizontal position shown and is held in that position by a flat leaf spring 48 having a median portion secured at 50 to the rung and end portions projecting laterally at 52 and terminating in flared free ends 54 which contact the bottom slidingly in the manner shown in FIG. 4.

The foregoing is considered as illustrative only of the principles of the invention. Further, since numerous modifications and changes will readily occur to those skilled in the art, it is not desired to limit the invention to the

3

exact construction and operation shown and described, and accordingly all suitable modifications and equivalents may be resorted to, falling within the scope of the invention as claimed.

What is claimed as new is as follows:

1. A leg lounger comprising: a portable self-supporting stand embodying a pair of spaced vertical inverted V-shaped end frames, each end frame comprising a pair of like legs having upwardly converging ends joined by an intervening fixedly mounted head block and having lower diverging ends provided with swivelly mounted self-leveling floor-engaging feet, an elongated horizontally disposed rung spanning the space between said end frames and having terminal ends securely joined to coacting central portions of the respective head blocks, a pair of reinforcing rails also spanning the space between said end frames and having their end portions joined to median portions of the respectively cooperable legs, said rails being disposed in a common plane with each other and in a plane below the plane of said rung, a foot and leg lounging rest located in the space between the respectively cooperable head blocks, said rest having a bottom provided with attached clips and said clips having portions pivotally connected to cooperating portions of said rung and permitting said rest to tilt and incline toward as well as away from a seated user, and spring means for positioning and retaining said rest in a normally horizontal at rest position, said spring means com-

4

prising a leaf spring of predetermined length and inherent tension properties located in a position at right angles to said rung and having a median portion secured to said rung and free terminal ends residing beneath and having freely slidable contact with coacting surfaces of said bottom.

2. A foot and leg lounger comprising: a portable self-supporting stand having a horizontal elevated rung, an upholstered cushion having a bottom portion provided with attaching clips pivotally mounted on said rung in a manner to allow the cushion to rock and incline toward and from the seated user, and spring means for positioning and retaining said rest in a normally horizontal at rest position, said spring means comprising a leaf spring of predetermined length and inherent tension properties located in a position at right angles to said rung and having a median portion secured to said rung and free terminal ends residing beneath and having freely slidable contact with coacting surfaces of said bottom.

References Cited

UNITED STATES PATENTS

3,371,962	3/1968	Bellock	-----	297-439
2,912,046	11/1959	Fuerst	-----	297-439X

CASMIR A. NUNBERG, Primary Examiner

U.S. Cl. X.R.

297-461