

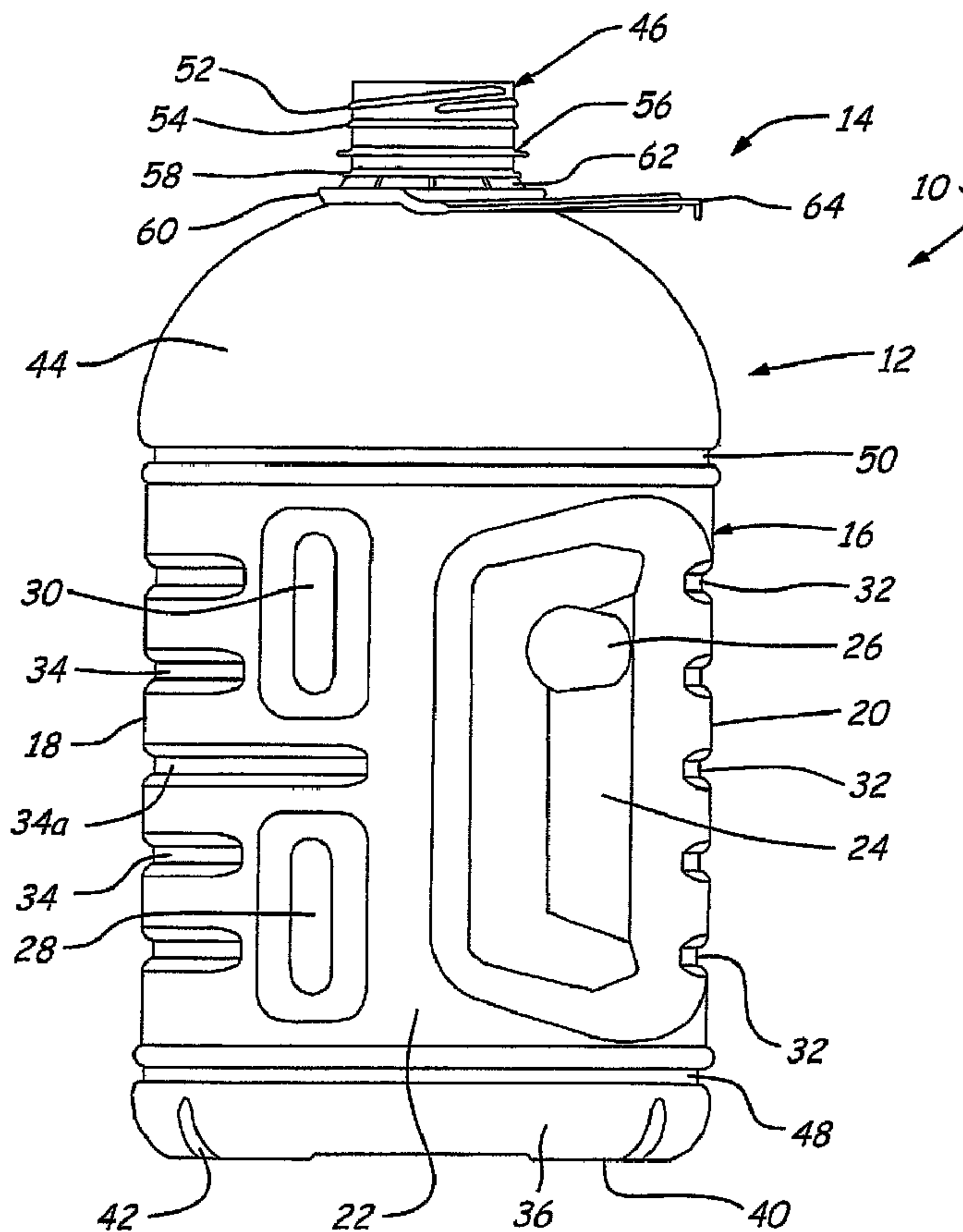

(86) Date de dépôt PCT/PCT Filing Date: 2004/08/13
 (87) Date publication PCT/PCT Publication Date: 2005/02/24
 (45) Date de délivrance/Issue Date: 2009/04/07
 (85) Entrée phase nationale/National Entry: 2006/02/14
 (86) N° demande PCT/PCT Application No.: US 2004/026507
 (87) N° publication PCT/PCT Publication No.: 2005/016769
 (30) Priorité/Priority: 2003/08/14 (US10/643,217)

(51) Cl.Int./Int.Cl. *B65D 1/02* (2006.01)
 (72) Inventeurs/Inventors:
 SIMPSON, CHARLES P., JR., US;
 GUERIN, STEPHEN R., US;
 PICCIOLI, DAVID P., US;
 ZHANG, QIUCHEN PETER, US
 (73) Propriétaire/Owner:
 GRAHAM PACKAGING PET TECHNOLOGIES INC., US
 (74) Agent: OGILVY RENAULT LLP/S.E.N.C.R.L.,S.R.L.

(54) Titre : RECIPIENT PLASTIQUE MOULE
 (54) Title: MOLDED PLASTIC CONTAINER



(57) Abrégé/Abstract:

A container (12) includes a hollow body (16) having a finish extending from the body. The finish has an open end, at least one external thread (52) for securement of a closure, and a pair of spaced external circumferential flanges (56, 58) on a side of the

(57) **Abrégé(suite)/Abstract(continued):**

thread remote from the open end of the finish. A bale handle (14) includes a ring (60) having resilient internal tabs (62) captured beneath the lower of the flanges (56, 58) remote from the open end of the finish, and a handle (64) extending from the ring (66) for carrying the container (12). The upper flange (56), which preferably has a greater outside diameter than the lower flange (58), has an undersurface that is free of obstruction from the bale handle (14) and therefore is adapted to perform support functions for the container (12) after attachment of the bale handle (14) to the container finish.

(12) INTERNATIONAL APPLICATION PUBLISHED UNDER THE PATENT COOPERATION TREATY (PCT)

(19) World Intellectual Property
Organization
International Bureau



(43) International Publication Date
24 February 2005 (24.02.2005)

PCT

(10) International Publication Number
WO 2005/016769 A1

(51) International Patent Classification⁷: **B65D 1/02**

(21) International Application Number:
PCT/US2004/026507

(22) International Filing Date: 13 August 2004 (13.08.2004)

(25) Filing Language: English

(26) Publication Language: English

(30) Priority Data:
10/643,217 14 August 2003 (14.08.2003) US

(71) Applicant (for all designated States except US): **GRAHAM PACKAGING PET TECHNOLOGIES INC.**
[US/US]; 2401 Pleasant Valley Road, York, PA 17402 (US).

(72) Inventors; and

(75) Inventors/Applicants (for US only): **SIMPSON, Charles,**

P., Jr. [US/US]; 4785 Basin, Adrian, MI 49221 (US).
GUERIN, Stephen, R. [US/US]; 19 Oakland Drive, Milford, NH 03055 (US). **PICCIOLI, David, P.** [US/US]; 142 Spruce Lane, Auburn, NH 03032 (US). **ZHANG, Qiuchen, Peter** [US/US]; 290 Blue Jacket Road, Perrysburg, OH 43551 (US).

(74) Agents: **HADDAWAY, Keith, G.** et al.; Venable LLP, P.O. Box 34385, Washington, DC 20043-9998 (US).

(81) Designated States (unless otherwise indicated, for every kind of national protection available): AE, AG, AL, AM, AT, AU, AZ, BA, BB, BG, BR, BW, BY, BZ, CA, CH, CN, CO, CR, CU, CZ, DE, DK, DM, DZ, EC, EE, EG, ES, FI, GB, GD, GE, GH, GM, HR, HU, ID, IL, IN, IS, JP, KE, KG, KP, KR, KZ, LC, LK, LR, LS, LT, LU, LV, MA, MD, MG, MK, MN, MW, MX, MZ, NA, NI, NO, NZ, OM, PG, PH, PL, PT, RO, RU, SC, SD, SE, SG, SK, SL, SY, TJ, TM, TN, TR, TT, TZ, UA, UG, US, UZ, VC, VN, YU, ZA, ZM, ZW.

[Continued on next page]

(54) Title: MOLDED PLASTIC CONTAINER

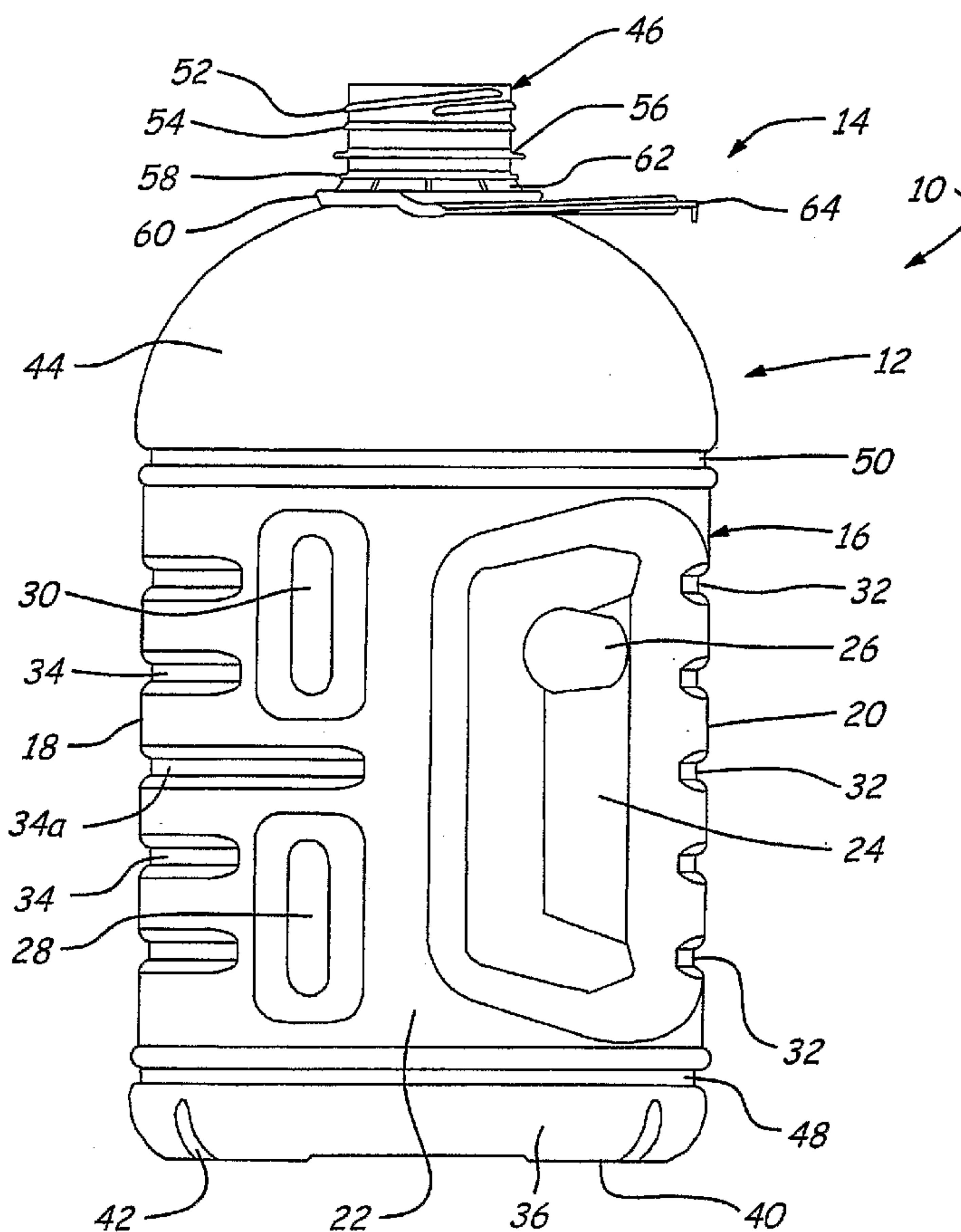

(57) Abstract: A container (12) includes a hollow body (16) having a finish extending from the body. The finish has an open end, at least one external thread (52) for securement of a closure, and a pair of spaced external circumferential flanges (56, 58) on a side of the thread remote from the open end of the finish. A bale handle (14) includes a ring (60) having resilient internal tabs (62) captured beneath the lower of the flanges (56, 58) remote from the open end of the finish, and a handle (64) extending from the ring (66) for carrying the container (12). The upper flange (56), which preferably has a greater outside diameter than the lower flange (58), has an undersurface that is free of obstruction from the bale handle (14) and therefore is adapted to perform support functions for the container (12) after attachment of the bale handle (14) to the container finish.

WO 2005/016769 A1

WO 2005/016769 A1



(84) **Designated States** (unless otherwise indicated, for every kind of regional protection available): ARIPO (BW, GH, GM, KE, LS, MW, MZ, NA, SD, SL, SZ, TZ, UG, ZM, ZW), Eurasian (AM, AZ, BY, KG, KZ, MD, RU, TJ, TM), European (AT, BE, BG, CH, CY, CZ, DE, DK, EE, ES, FI, FR, GB, GR, HU, IE, IT, LU, MC, NL, PL, PT, RO, SE, SI, SK, TR), OAPI (BF, BJ, CF, CG, CI, CM, GA, GN, GQ, GW, ML, MR, NE, SN, TD, TG).

Declarations under Rule 4.17:

— as to applicant's entitlement to apply for and be granted a patent (Rule 4.17(ii)) for the following designations AE, AG, AL, AM, AT, AU, AZ, BA, BB, BG, BR, BW, BY, BZ, CA, CH, CN, CO, CR, CU, CZ, DE, DK, DM, DZ, EC, EE, EG, ES, FI, GB, GD, GE, GH, GM, HR, HU, ID, IL, IN, IS, JP, KE, KG, KP, KR, KZ, LC, LK, LR, LS, LT, LU, LV, MA, MD, MG, MK, MN, MW, MX, MZ, NA, NI, NO, NZ, OM, PG, PH, PL, PT, RO, RU, SC, SD, SE, SG, SK, SL, SY, TJ, TM, TN, TR, TT, TZ, UA, UG, UZ, VC, VN, YU, ZA, ZM, ZW, ARIPO patent (BW, GH, GM, KE, LS, MW, MZ, NA, SD, SL, SZ, TZ, UG, ZM, ZW), Eurasian patent (AM, AZ, BY, KG, KZ, MD, RU, TJ, TM), European patent (AT, BE, BG, CH, CY, CZ, DE, DK, EE, ES, FI, FR, GB, GR, HU, IE, IT, LU, MC, NL, PL, PT, RO, SE, SI, SK, TR), OAPI patent (BF, BJ, CF, CG, CI, CM, GA, GN, GQ, GW, ML, MR, NE, SN, TD, TG)

— as to the applicant's entitlement to claim the priority of the earlier application (Rule 4.17(iii)) for the following designations AE, AG, AL, AM, AT, AU, AZ, BA, BB, BG, BR, BW, BY, BZ, CA, CH, CN, CO, CR, CU, CZ, DE, DK, DM, DZ, EC, EE, EG, ES, FI, GB, GD, GE, GH, GM, HR, HU, ID, IL, IN, IS, JP, KE, KG, KP, KR, KZ, LC, LK, LR, LS, LT, LU, LV, MA, MD, MG, MK, MN, MW, MX, MZ, NA, NI, NO, NZ, OM, PG, PH, PL, PT, RO, RU, SC, SD, SE, SG, SK, SL, SY, TJ, TM, TN, TR, TT, TZ, UA, UG, UZ, VC, VN, YU, ZA, ZM, ZW, ARIPO patent (BW, GH, GM, KE, LS, MW, MZ, NA, SD, SL, SZ, TZ, UG, ZM, ZW), Eurasian patent (AM, AZ, BY, KG, KZ, MD, RU, TJ, TM), European patent (AT, BE, BG, CH, CY, CZ, DE, DK, EE, ES, FI, FR, GB, GR, HU, IE, IT, LU, MC, NL, PL, PT, RO, SE, SI, SK, TR), OAPI patent (BF, BJ, CF, CG, CI, CM, GA, GN, GQ, GW, ML, MR, NE, SN, TD, TG)

Published:

— with international search report
 — before the expiration of the time limit for amending the claims and to be republished in the event of receipt of amendments

For two-letter codes and other abbreviations, refer to the "Guidance Notes on Codes and Abbreviations" appearing at the beginning of each regular issue of the PCT Gazette.

MOLDED PLASTIC CONTAINER

The present invention is directed to molded plastic containers, and more particularly to a one-gallon hot-fill molded plastic container having a bale handle assembled to the container finish.

Background and Summary of the Invention

In so-called hot-fill packages, a container is filled with hot liquid product and capped while the liquid product is still hot. As the liquid cools, the reduction in liquid volume creates a vacuum within the package - i.e., an internal pressure that is less than the surrounding atmospheric pressure. When the container is of molded plastic construction, the container wall tends to distort inwardly as the liquid cools. This problem is exacerbated when the container is relatively large and/or has flat walls. It has been proposed to provide ribs or channels on the container walls to strengthen the walls against distortion, and to provide vacuum panel areas on the container walls for controlling the areas of distortion under vacuum. These measures have not been entirely effective in containers of larger size. Hot-fill containers of relatively large capacity, such as one-gallon containers, typically are of cylindrical wall construction to take advantage of the inherent strength of a cylindrical wall geometry and to avoid the use of large flat wall panel areas at which distortion can occur.

Another problem in the art, as applied particularly to containers of larger size, involves attachment of bale handles to the container finish to facilitate carrying of the filled container by a consumer. Molded plastic containers typically have a flange that extends circumferentially around the container finish. This flange, often referred to as a capping flange or a support flange,

serves a variety of support functions during automated fabrication and handling of the container. Attachment of a bale handle to the container finish beneath the flange obstructs the area beneath the flange and makes these support functions more difficult during container filling and capping, for example.

The present invention involves a number of different aspects that may be implemented separately from or, more preferably, in combination with each other.

A container in accordance with a first aspect of the present invention includes a hollow body having a finish extending from the body. The finish has an open end, at least one external thread for securement of a closure, and a pair of spaced external circumferential flanges on a side of the thread remote from the open end of the finish. A bale handle includes a ring having resilient internal tabs captured beneath the lower of the flanges remote from the open end of the finish, and a handle extending from the ring for carrying the container. The upper flange, which preferably has a greater outside diameter than the lower flange, has an undersurface that is free of obstruction from the bale handle and therefore is adapted to perform support functions for the container after attachment of the bale handle to the container finish.

A one-gallon rectangular hot-fill container in accordance with a second aspect of the invention includes a rectangular body having a front wall, a back wall and opposed sidewalls, a bottom wall with a central push-up feature, an externally threaded finish and a shoulder connecting the finish to the body. The sidewalls have recessed handle areas adjacent to the back wall and flexible hot-fill panels adjacent to the front wall. The back wall has strengthening channels that extend between the handle areas. The front wall has strengthening channels that extend between and into the sidewalls. The body has a pair of spaced channels that extend entirely around the body

between the sidewalls, front wall and back wall, and the bottom wall and the shoulder respectively. One of the channels on the front wall extends into the sidewalls between the hot-fill panels on the sidewalls. The rectangular container is specifically adapted for hot-fill applications with minimum wall distortion, and the rectangular geometry of the container body lends itself to close-packing on store shelves with minimum wasted shelf area.

In accordance with one aspect of the present invention, there is provided a blow molded plastic container that includes a body and a finish extending from said body, said finish including an open upper end, at least one external thread beneath said upper end, an external bead beneath said at least one thread for cooperating with tamper-indicating means on a closure secured to said finish, and a pair of upper and lower spaced circumferential flanges beneath said bead; and a bale handle captured on said finish beneath said lower flange.

In accordance with another aspect of the present invention, there is also provided a blow molded plastic container that includes a body and a finish extending from said body, said finish including an open upper end, at least one external thread beneath said upper end, an external bead beneath said at least one thread for cooperating with tamper-indicating means on a closure secured to said finish, and a pair of spaced circumferential flanges beneath said bead, wherein said spaced circumferential flanges include an upper flange and a lower flange, each flange having an undersurface, and said upper flange having a greater external diameter than said lower flange.

In accordance with yet another aspect of the present invention, there is also provided a container that includes: a hollow body having a finish extending from said body, said finish having an open end, at least one external thread for securement of a closure, and a pair of spaced external circumferential flanges on a side of said at least one thread remote from said open end, and a bale handle that includes a ring having resilient internal tabs captured beneath the lower of said flanges remote from said open end, and a handle extending from said ring for carrying the container, the upper of said flanges having an undersurface that is free of obstruction from said bale handle, and wherein said upper flange has a greater outside diameter than said lower flange.

In accordance with yet another aspect of the present invention, there is also provided a one-gallon rectangular hot-fill container that includes: a rectangular body having a front wall, a back wall and opposed sidewalls, a bottom wall with a central push-up feature, an externally threaded finish and a shoulder connecting said finish to said body, said body including said shoulder having a one-gallon fill capacity, said sidewalls having recessed handle areas adjacent to said back wall and a pair of axially spaced flexible hot-fill panels on each sidewall adjacent to said front wall, said back wall having strengthening channels that extend between said handle areas, said front wall having strengthening channels that extend between and into said sidewalls, said body having a pair of spaced channels that extend entirely around said body between said sidewalls, front wall and back wall, and said bottom wall and said shoulder respectively, one of said channels on said front wall extending into said sidewalls between said pair of hot-fill panels.

Brief Description of the Drawings

The invention, together with additional objects, features, advantages and aspects thereof, will be best understood from the following description, the appended claims and the accompanying drawings, in which

FIG. 1 is a side elevational view of a container in accordance with one presently preferred embodiment of the invention;

FIG. 2 is a rear elevational view of the container illustrated in FIG. 1 minus the bale handle;

FIG. 3 is a front elevational view of the container in FIG. 1 without the bale handle;

FIG. 4 is a bottom plan view of the container in FIG. 1;

FIG. 5 is a fragmentary exploded elevational view that illustrates the bale handle removed from the container finish in FIG. 1;

FIG. 6 is a fragmentary sectional view of the portion of FIG. 5 within the area 6;

FIG. 7 is a top plan view of the bale handle secured to the container finish; and

FIGS. 8 and 9 are fragmentary perspective views of the container bottom in accordance with modified embodiments of the invention.

Detailed Description of Preferred Embodiments

FIG. 1 illustrates a container and handle assembly 10 in accordance with one presently preferred embodiment of the invention as including a container 12 having a bale handle 14 secured thereto. Container 12 is of one-piece integrally molded plastic construction, such as polyethylene terephthalate (PET). Container 12 includes a generally rectangular body 16 having a front wall 18, a back wall 20 and laterally opposed sidewalls 22. Sidewalls 22, which are mirror images of each other, have opposed generally trapezoidal recessed handle areas 24 adjacent to and intersecting back wall 20. Each recessed handle area 24 includes a recessed thumb area 26 to facilitate grasping of the container for pouring. A pair of axially spaced vacuum panels 28, 30 are provided on each sidewall 22 between handle area 24 and front wall 18. (Directional words such as "axial" and "lateral" are used by way of description and not limitation with respect to the axis of the container finish, which is concentric with the central axis of body 16 in the preferred embodiments of the invention.) An axially spaced array of laterally extending strengthening channels 32 are provided on back wall 20 between recessed handle areas 24. Likewise, an array of axially spaced laterally extending strengthening channels 34 are provided on front wall 18. Channels 34 extend around the corner of front wall 18 into sidewalls 22. One of the channels 34a is elongated, as best seen in FIG. 1, and extends between vacuum panels 28, 30 on each sidewall 22.

Container 12 also includes a bottom wall 36 having a central push-up feature 38 (FIG. 4) for strengthening the bottom wall under vacuum. Bottom wall 36 has an axially extending foot 40 at each corner, with a strengthening channel 42 bisecting each foot 40. A shoulder 44 extends upwardly from body 16 to a container finish 46. Body 16 is isolated from bottom wall 36 and

shoulder 44 by a pair of channels 48, 50 that extend entirely around the container body in planes parallel to the axis of finish 46.

Referring in particular to FIGS. 5 and 6, container finish 46 is of cylindrical geometry, and includes one or more external threads 52 for securement of a closure to the finish. A bead 54 extends circumferentially around finish 46 at a position beneath thread 52 for cooperation with tamper-indicating means on the closure. Such tamper-indicating means are illustrated, for example, in U.S. Patents 4,984,703 and Re 33,265. An external support flange 56 extends circumferentially around finish 46 at a position beneath bead 54. A second external flange 58 extends circumferentially around finish 46 at a position spaced beneath flange 56. The undersurfaces of flanges 56,58 lie in planes that are parallel to each other and perpendicular to the central axis of finish 46. As best seen in FIGS. 5 and 6, the outside diameter of upper flange 56 is greater than the outside diameter of lower flange 58. In one presently preferred implementation of the invention on a 48 mm finish, flange 56 has a nominal external diameter of 2.100 inches and flange 58 has a nominal external diameter of 1.980 inches. The axial spacing between the undersurfaces of flanges 56,58 in this embodiment of the invention is 0.236 inch.

Bale handle 14 (FIGS. 1,5 and 7) includes a circumferentially continuous annular ring 60 having a plurality of angulated flexible tabs 62 projecting radially inwardly therefrom. A handle 64 is externally secured to ring 60 and extends outwardly from the ring for positioning over shoulder 44, as best seen in FIG. 1. Ring 60 and tabs 62 are dimensioned and oriented so that the ring may be axially pushed over the external surface features of finish 46 until tabs 62 are disposed beneath lower flange 58. Ring 60 and handle 14 are thus captured beneath flange 58 between the

undersurface of the flange and the upper outer surface of container shoulder 44. Tabs 62 of bale handle engage an undersurface of flange 58, at least when the bale handle is used for carrying the container. Bale handle 14 is thus captured in assembly beneath lower flange 58, leaving the undersurface of upper flange 56 unobstructed and free for performing guide and/or support functions during further processing of container 10 - e.g., during filling, capping, labeling and boxing of the container.

FIGS. 8 and 9 illustrate modified embodiments of container bottom wall 36. In FIG. 8, bottom wall 36a has upstanding feet 70 disposed at each corner of the bottom wall. FIG. 9 illustrates an embodiment in which the feet form part of the outer surface of bottom wall 36b.

There has thus been disclosed a container that fully satisfies all of the objects and aims previously set forth. The container has been disclosed in conjunction with three presently preferred embodiments thereof, and other modifications and variations have been described. Further modifications and variations will readily suggest themselves to persons of ordinary skill in the art. The invention is intended to embrace all such modifications and variations as fall within the spirit and broad scope of the appended claims.

Claims:

1. A blow molded plastic container that includes a body and a finish extending from said body,
 said finish including an open upper end, at least one external thread beneath said upper end, an external bead beneath said at least one thread for cooperating with tamper-indicating means on a closure secured to said finish, and a pair of upper and lower spaced circumferential flanges beneath said bead; and
 a bale handle captured on said finish beneath said lower flange.

2. A blow molded plastic container that includes a body and a finish extending from said body,
 said finish including an open upper end, at least one external thread beneath said upper end, an external bead beneath said at least one thread for cooperating with tamper-indicating means on a closure secured to said finish, and a pair of spaced circumferential flanges beneath said bead, wherein said spaced circumferential flanges include an upper flange and a lower flange, each flange having an undersurface, and said upper flange having a greater external diameter than said lower flange.

3. The container set forth in claim 2 further including a bale handle captured on said finish beneath said undersurface of the lower flange.

4. A container that includes:
 a hollow body having a finish extending from said body,
 said finish having an open end, at least one external thread for securement of a closure, and a pair of spaced external circumferential flanges on a side of said at least one thread remote from said open end, and
 a bale handle that includes a ring having resilient internal tabs captured beneath the lower of said flanges remote from said open end, and a handle extending from said ring for carrying the container,
 the upper of said flanges having an undersurface that is free of obstruction from said bale handle, and

wherein said upper flange has a greater outside diameter than said lower flange.

5. The container set forth in claim 1 having a capacity of at least one gallon.
6. The container set forth in claim 1 being a hot-fillable container.
7. The container set forth in claim 1 wherein the bale handle includes a ring having resilient internal tabs captured beneath the lower flange, and a handle extending from the ring for carrying the container.
8. The container set forth in claim 1 wherein the upper flange has a greater external diameter than the lower flange.
9. The container set forth in claim 1 wherein the bale handle includes a ring having resilient internal tabs captured beneath the lower flange, and a handle extending from the ring for carrying the container.

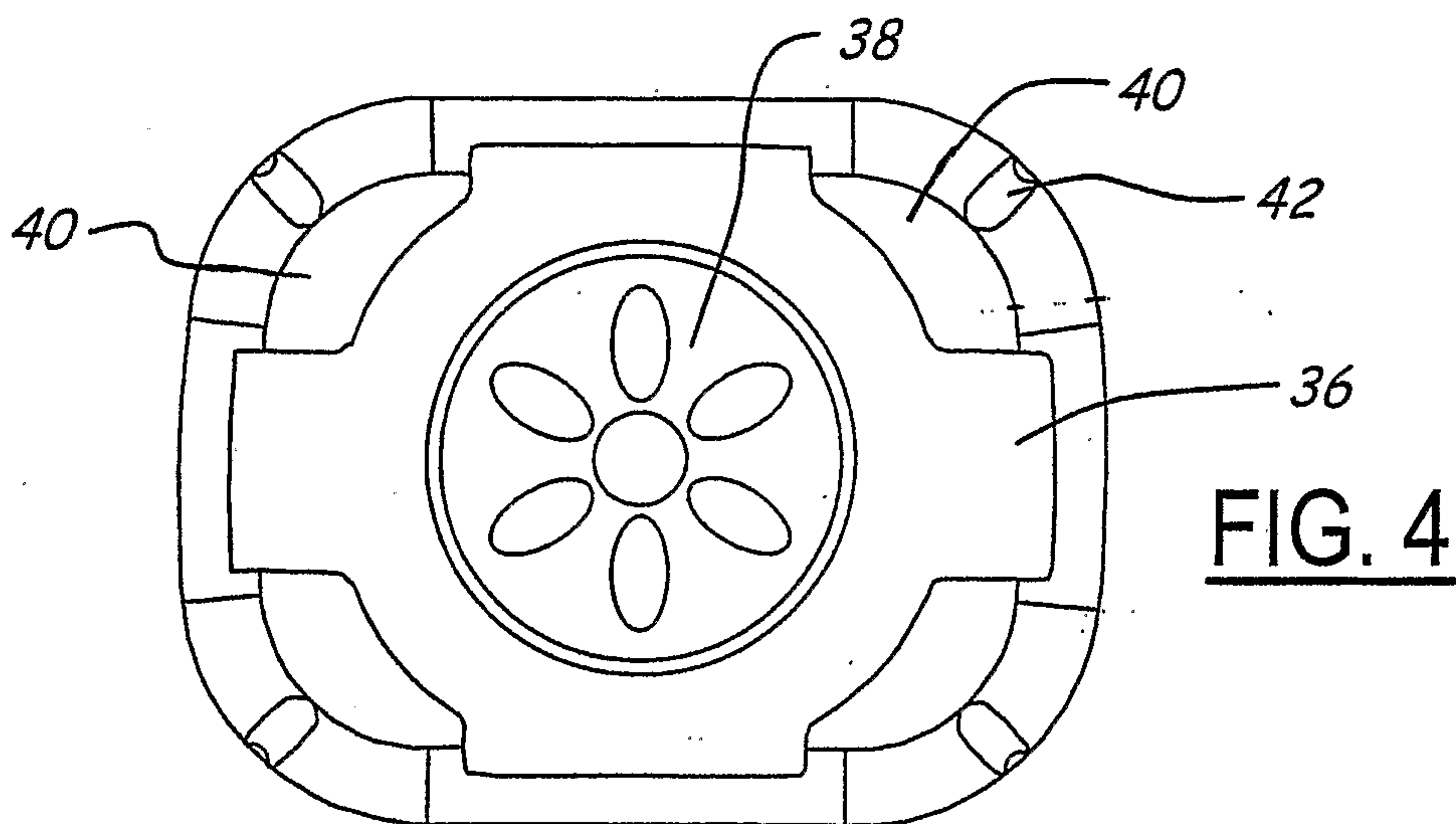
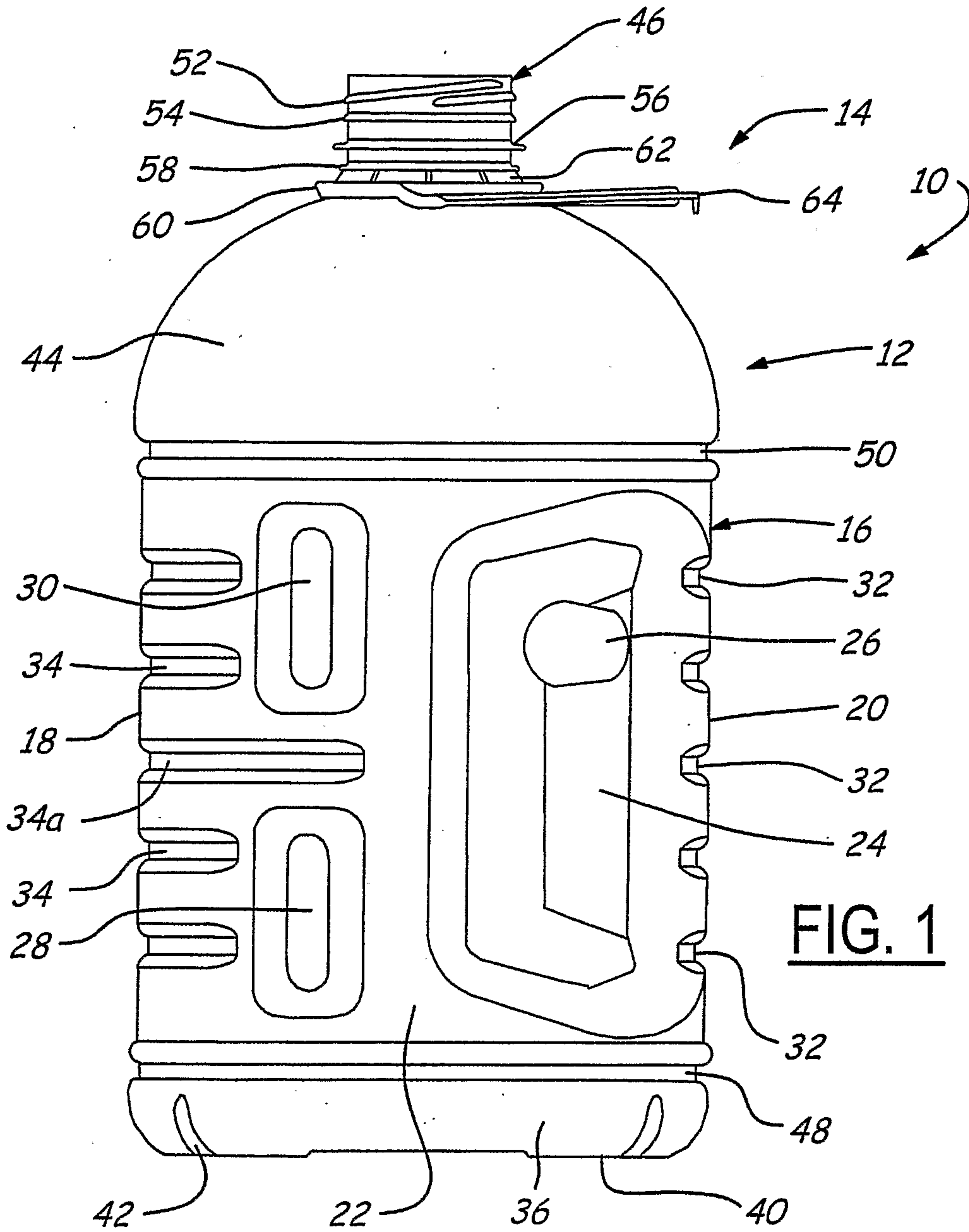

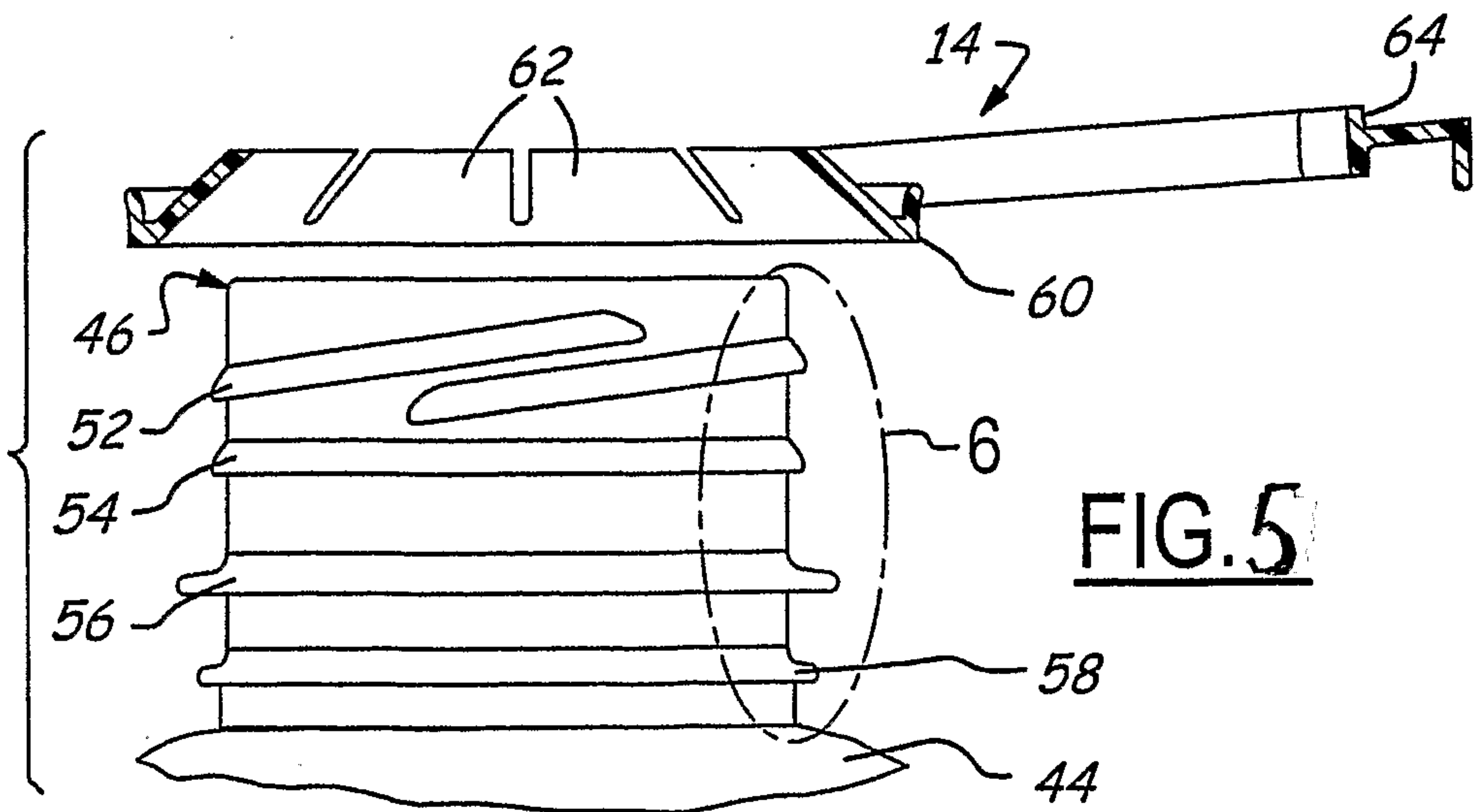
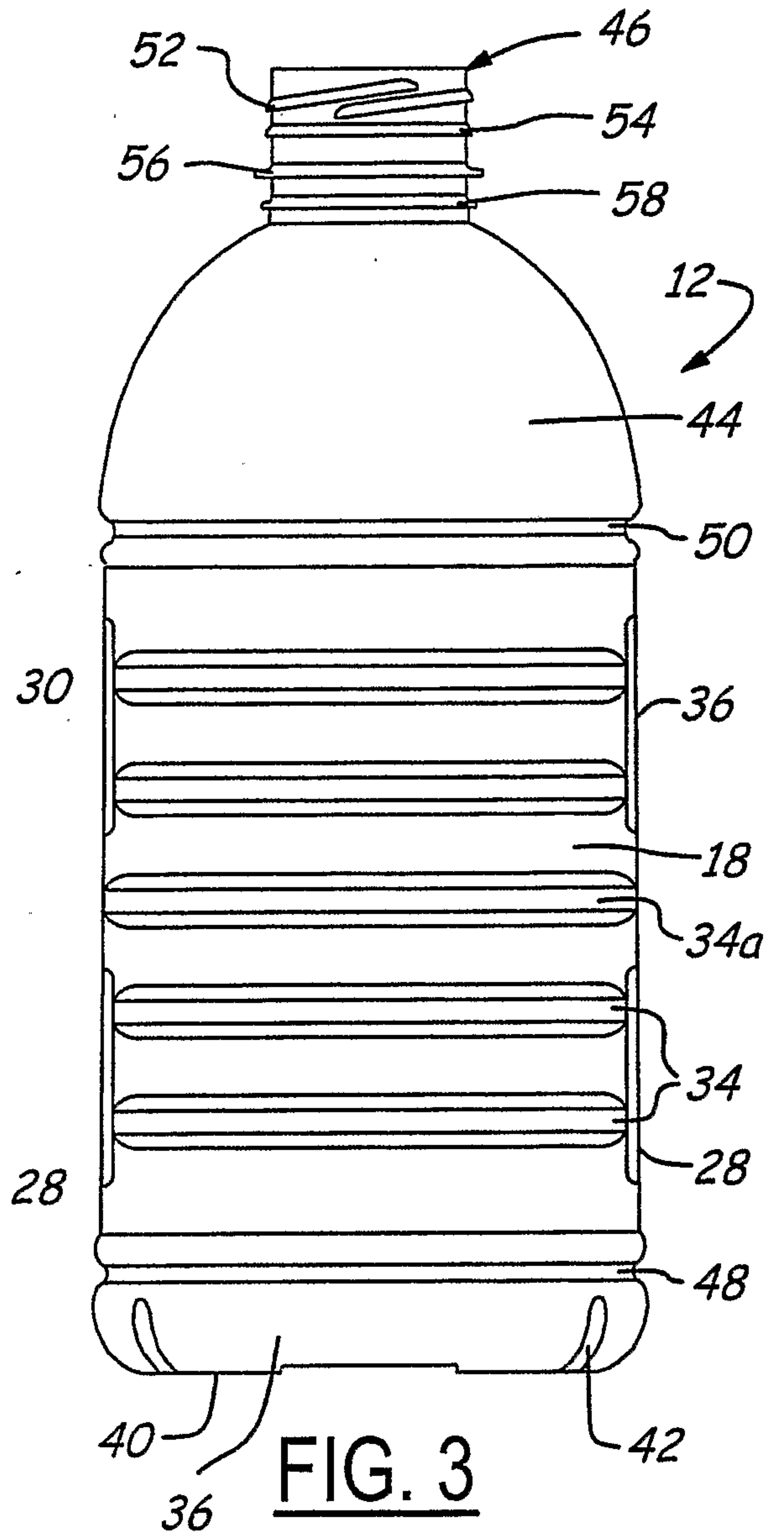
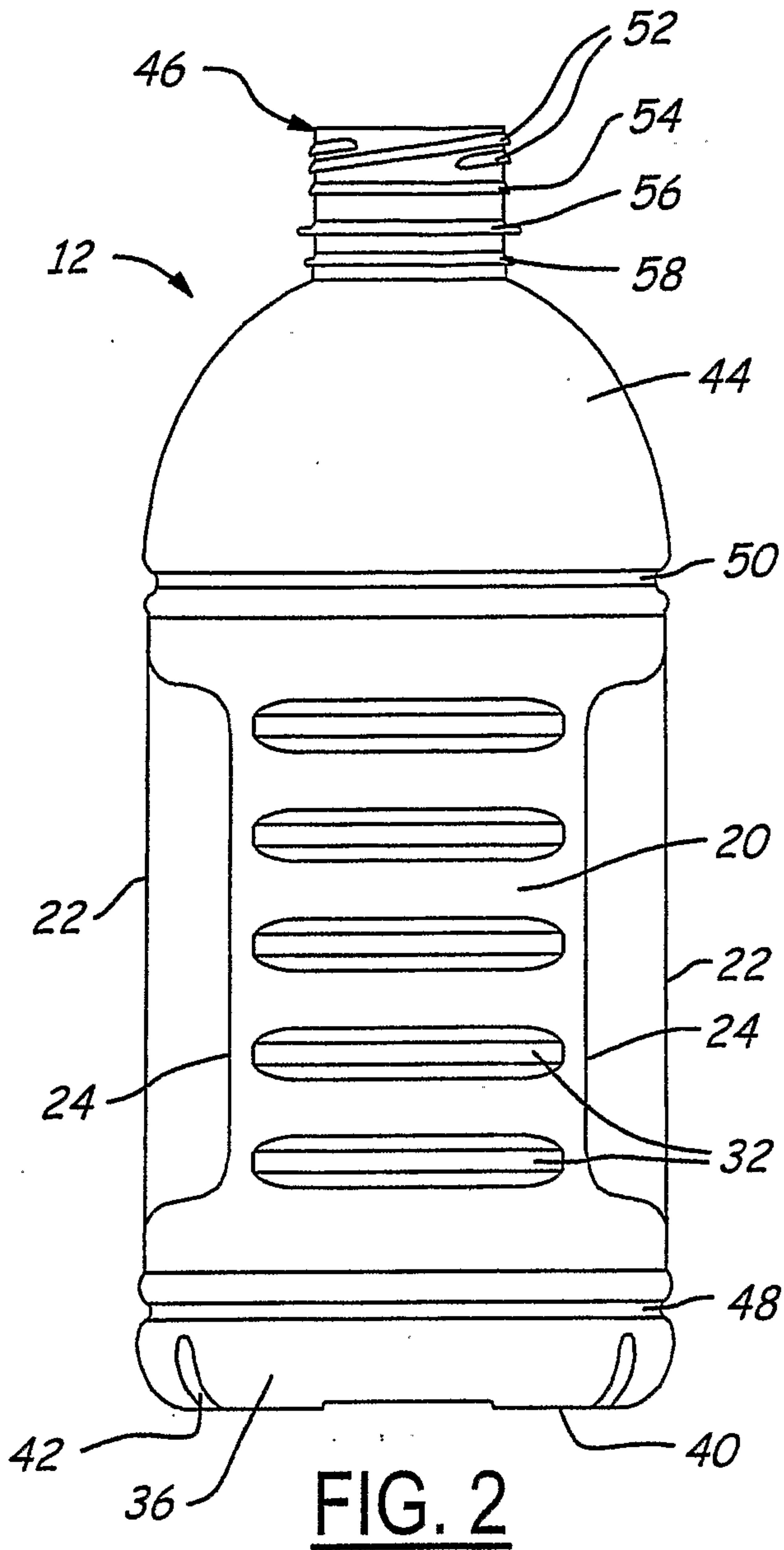

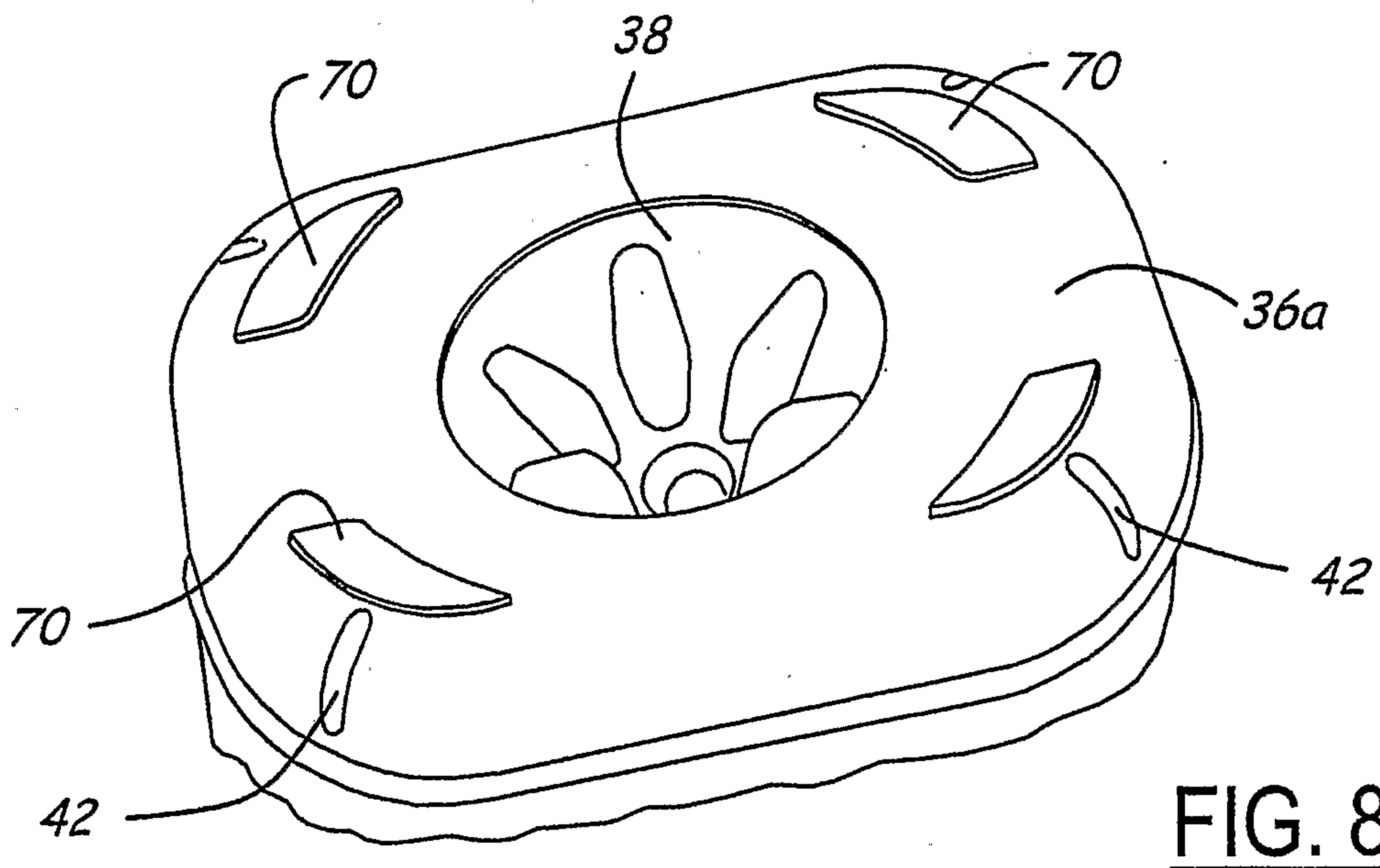
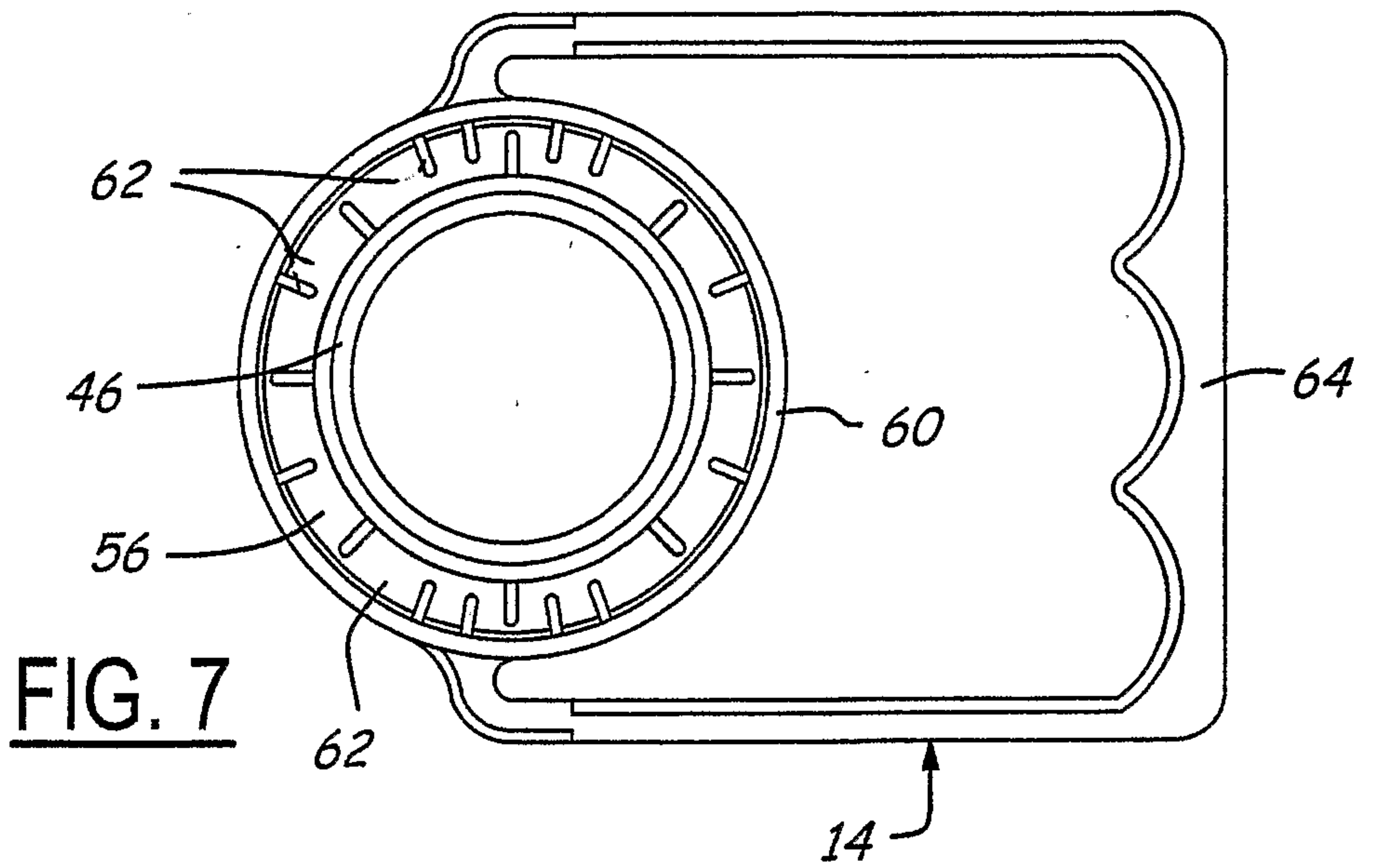
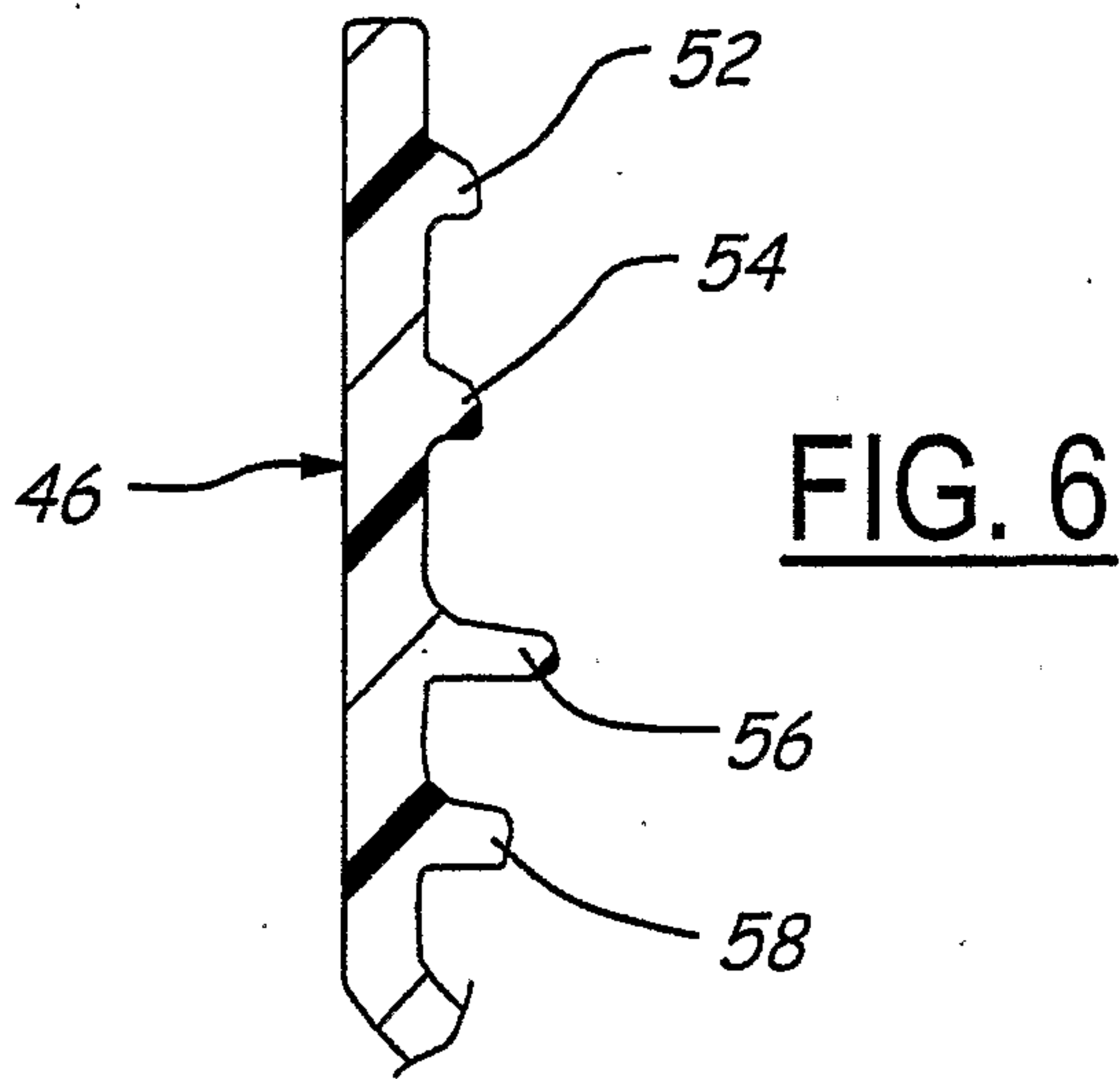

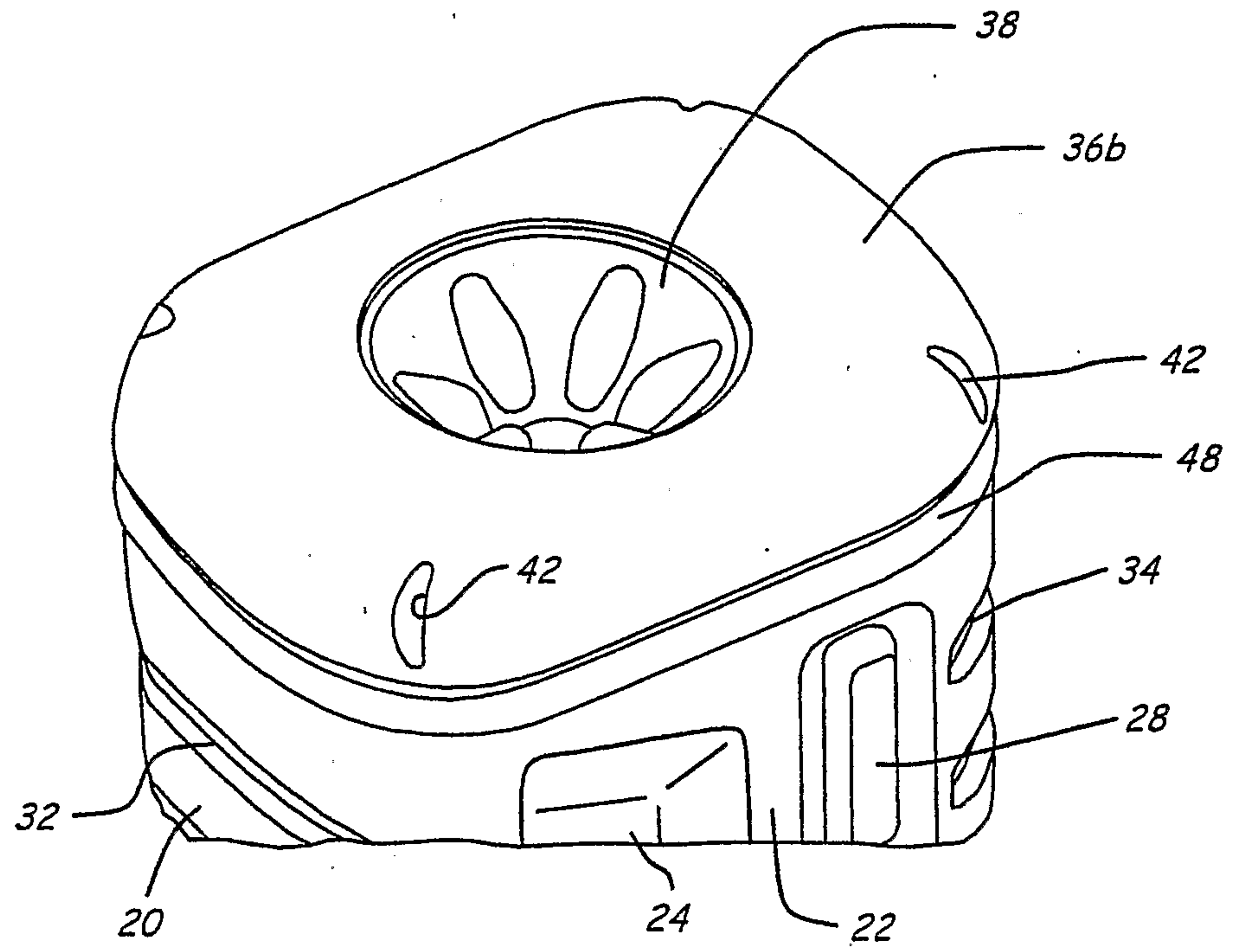

FIG. 9

