

M. BURTON.
MECHANICAL MOVEMENT.
APPLICATION FILED AUG. 30, 1902.

NO MODEL.

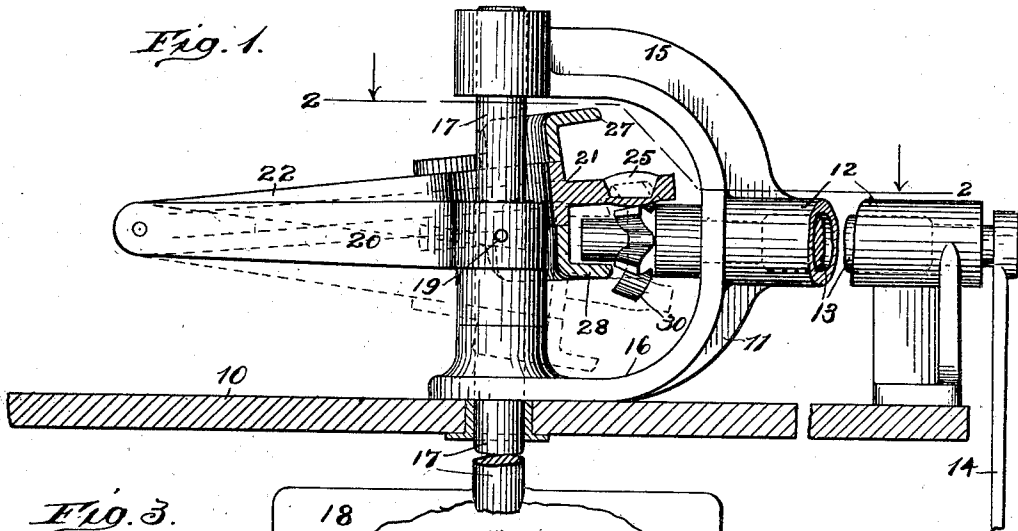

Fig. 3.

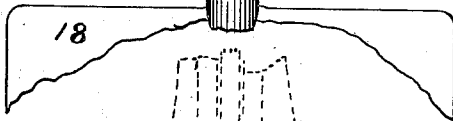
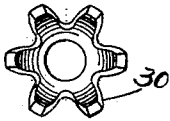

Fig. 2.

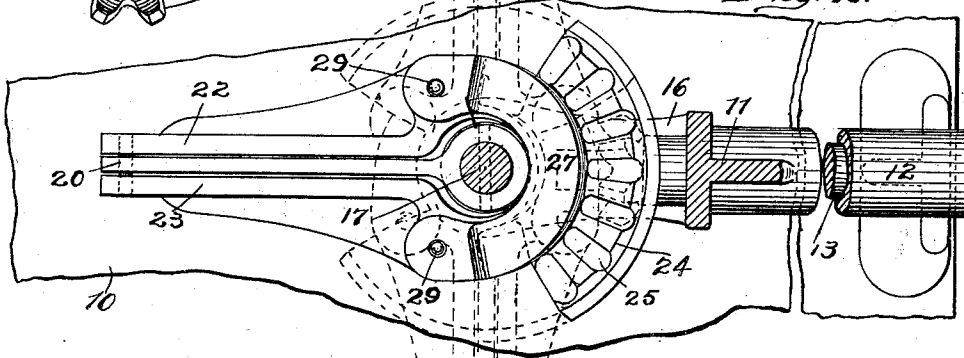

Fig. 5.

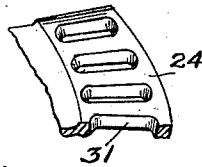
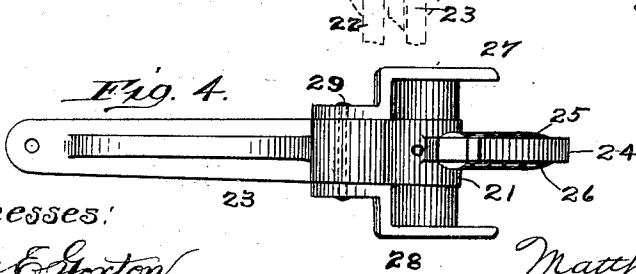

Fig. 4.



Witnesses:

Chas. E. Gorton,
A. Gustafson.

Inventor:

Matthew Burton.
By *Chas. A. Tillman*
Att'y

UNITED STATES PATENT OFFICE.

MATTHEW BURTON, OF BATAVIA, ILLINOIS.

MECHANICAL MOVEMENT.

SPECIFICATION forming part of Letters Patent No. 731,277, dated June 16, 1903.

Application filed August 30, 1902. Serial No. 121,553. (No model.)

to all whom it may concern:

Be it known that I, MATTHEW BURTON, a citizen of the United States, residing at Batavia, in the county of Kane and State of Illinois, have invented certain new and useful Improvements in Mechanical Movements, of which the following is a specification.

This invention relates to improvements in mechanical movements to be employed for various useful purposes, but is more particularly intended for washing-machines; and it consists in certain peculiarities of the construction, novel arrangement, and operation of the various parts thereof, as will be hereinafter more fully set forth and specifically claimed.

The principal object of the invention is to provide a mechanism of simple and inexpensive construction for converting continuous rotary motion into reciprocating rotary or alternating rotary movement.

Another object is to furnish a mechanism of the above-named character in which great power will be afforded by a minimum amount of effort or exertion.

Other objects and advantages of the invention will be disclosed in the subjoined description and explanation.

In order to enable others skilled in the art to which my invention pertains to make and use the same, I will now proceed to describe it, referring to the accompanying drawings, in which—

Figure 1 is a side view, partly in section and partly in elevation, of a movement embodying my invention, showing a part of the frame and shafts shortened for the convenience of illustration and illustrating by dotted lines the movement of the parts. Fig. 2 is a plan view, partly in section, taken on line 2 2 of Fig. 1, looking in the direction indicated by the arrows, illustrating by dotted lines the positions which the reciprocal shaft and the rack thereon will assume in the operation of the movement. Fig. 3 is a detached view of the pinion of the driving-shaft. Fig. 4 is a view in side elevation of the segmental rack, the guides, and arms or prongs thereof; and Fig. 5 is a perspective view of a portion of the rack, showing a modification in its construction.

Like numerals of reference refer to corre-

sponding parts throughout the different views of the drawings.

The numeral 10 represents the support upon which the movement is mounted and which support may be the cover or top of a washing-machine, churn, or other apparatus to which it is desired to apply the mechanism. Mounted on the support 10 is a frame 11, which is provided with a hollow portion 12 to receive the power or driving shaft 13, to which power may be applied by means of a crank 14, attached thereto or otherwise. The inner end of the hollow portion 12 of the frame is provided with prongs or extensions 15 and 16, which form, substantially, a horseshoe-shaped portion, and each of said prongs has in its free end an opening in which is journaled the operating or rotary reciprocal shaft 17, to one end of which is secured in any suitable manner an agitator or dasher 18 or other suitable device. Fixed on the shaft 17 by means of a pin 19 or otherwise and at about midway between the prongs 15 and 16 of the frame is an arm 20, which, as shown, stands at a right angle to the said shaft and projects a considerable distance therefrom. Located loosely around the shaft 17 and around the end of the arm 20 which is fixed to said shaft is a curved and bifurcated piece 21, the prongs or bifurcations 22 and 23 of which are pivotally secured at their outer ends to the corresponding end of the arm 20, as is clearly shown in Figs. 1 and 2 of the drawings. On the outer surface of the curved piece or portion 21 is a segmental rack 24, which has a row of gear-teeth 25 and 26 on its upper and lower surfaces, respectively. The curved piece 21 is provided on its upper and lower surfaces with guide-flanges 27 and 28, which project outwardly and which flanges may be made integral with the upper portion 21 or secured thereto by means of bolts 29, as is shown in the drawings. Journaled in the hollow portion 12 of the frame is the driving-shaft 13, on the inner portion of which is mounted a beveled pinion 30, which engages the teeth of the segmental rack, as is clearly shown in Fig. 1 of the drawings. The inner end of the shaft 13 projects beyond the pinion 30 so as to lie between the flanges 27 and 28 and the rack which form guides therefor.

By turning the driving-shaft 13 continuously in one direction it is apparent that the pinion 30 thereon will engage the teeth of the segmental rack first on one of its surfaces until it reaches the end thereof, when the pinion will pass over the end of the rack and engage the teeth thereof on the other surface, thus imparting to the shaft 17 a rotary reciprocal or alternating rotary movement. As the prongs 22 and 23 of the piece 21 which carries the rack are pivotally secured to the outer end of the arm 20, which, as before stated, is fixed on the reciprocal shaft, it is apparent that the rack will have a vertical or a longitudinal movement with respect to the reciprocal shaft, thus permitting the pinion 30 to engage the teeth on both of its surfaces. It is further evident that by pivoting or fulcruming the arms or prongs 22 and 23 to the outer end of the arm 20 and at some considerable distance from the reciprocal shaft I attain great leverage and power and am also enabled to reduce the size of the pinion 30, as well as the inclination of its bevel.

In Fig. 5 of the drawings I have shown a modified construction of the rack which consists in forming it with openings 31 for the reception of the teeth of the pinion instead of using the teeth 25 and 26 on each side thereof, as in the other form.

Having thus fully described my invention, what I claim as new, and desire to secure by Letters Patent, is—

1. In a mechanical movement, the combination with a rotary reciprocal shaft, of a segmental rack provided with a guide-flange near each of its faces, the said rack being

pivotally secured at a distance from said shaft but connected thereto and movable longitudinally therewith, a continuously-revoluble shaft having its inner end projecting so as to extend between the guide-flanges and rack, and a pinion on said shaft to engage the rack, substantially as described.

2. In a mechanical movement, the combination with a rotary reciprocal shaft, of an arm fixed thereto, a segmental rack having means to pivotally secure it to the outer end of said arm, a continuously-revoluble shaft and a pinion thereon to engage said rack, substantially as described.

3. In a mechanical movement, the combination with a rotary reciprocal shaft, of an arm fixed thereto, a bifurcated segmental rack striding said shaft and arm and pivotally secured to the outer portion of the arm, a continuously-revoluble shaft and a pinion thereon to engage said rack, substantially as described.

4. In a mechanical movement, the combination with a rotary reciprocal shaft, of an arm fixed thereto, a bifurcated segmental rack striding said shaft and arm and pivotally secured to the outer portion of the latter, a guide-flange located near each of the faces of the rack, a continuously-revoluble shaft having its inner end projected so as to extend between said flanges and rack, and a pinion on said shaft to engage the rack, substantially as described.

MATTHEW BURTON.

Witnesses:

CHAS. C. TILLMAN,
A. GUSTAFSON.