

(19)



(11)

EP 3 279 558 B1

(12)

EUROPEAN PATENT SPECIFICATION

(45) Date of publication and mention of the grant of the patent:
02.01.2019 Bulletin 2019/01

(51) Int Cl.:
F21V 23/00 ^(2015.01) **F21V 29/77** ^(2015.01)
F21V 15/01 ^(2006.01) **F21W 131/103** ^(2006.01)
F21S 9/02 ^(2006.01) **F21S 8/04** ^(2006.01)
F21Y 115/10 ^(2016.01) **F21Y 105/18** ^(2016.01)

(21) Application number: **16182513.8**

(22) Date of filing: **03.08.2016**

(54) **LUMINAIRE**

LEUCHTE

LUMINAIRE

(84) Designated Contracting States:
AL AT BE BG CH CY CZ DE DK EE ES FI FR GB GR HR HU IE IS IT LI LT LU LV MC MK MT NL NO PL PT RO RS SE SI SK SM TR

(43) Date of publication of application:
07.02.2018 Bulletin 2018/06

(73) Proprietor: **ZG Lighting Benelux**
2870 Puurs (BE)

(72) Inventors:
 • **Lambrechts, Jurgen**
2960 Sint-Lenaarts (BE)

• **Usher, Christian**
1183 HE Amstelveen (NL)

(74) Representative: **Kiwit, Benedikt**
Mitscherlich PartmbB
Patent- und Rechtsanwälte
Sonnenstraße 33
80331 München (DE)

(56) References cited:
WO-A1-2015/031322 **US-A1- 2009 147 510**
US-A1- 2011 032 696 **US-A1- 2011 101 861**
US-A1- 2011 316 014 **US-A1- 2013 044 478**
US-A1- 2014 204 562

EP 3 279 558 B1

Note: Within nine months of the publication of the mention of the grant of the European patent in the European Patent Bulletin, any person may give notice to the European Patent Office of opposition to that patent, in accordance with the Implementing Regulations. Notice of opposition shall not be deemed to have been filed until the opposition fee has been paid. (Art. 99(1) European Patent Convention).

Description

1. Field of the invention

[0001] The present invention relates to luminaires having a high lumen output resulting in an excessive heat generation.

2. Technical background

[0002] In the prior art, luminaires having a high lumen output are well known. Those luminaires usually comprise a driver and a light source having a light emitting direction of the light source for constituting a main beam direction of the luminaire. The driver is usually provided somewhere at the rear side of the luminaire with respect to the light emitting direction of the light source. In case of the luminaire directing light downwards, the heat being generated will rise and will pass the driver which is heated up and having an adverse effect on the driver. In such a case, the driver can be placed at a position not being affected by the heat of the luminaire, which, however, results in bigger dimensions of the luminaire.

[0003] US 2013/0044478 discloses a luminaire according to the preamble of claim 1.

[0004] Therefore, it is an object of the present invention to provide a luminaire that is compact and that allows that the driver is not being affected by the heat of the luminaire.

[0005] These and other objects, which become apparent upon reading the following description, are solved by the subject-matter of the independent claim. The dependent claims refer to preferred embodiments of the invention.

3. Summary of the invention

[0006] According to the invention, a luminaire having a main beam direction comprises a heatsink, a light source mounted to the heatsink, and a driver configured to drive the light source, wherein the driver is at least partially positioned on a side of the light source being opposite to the heatsink.

In the context of the present invention, the term "main beam direction" is to be understood as the direction of the emitted light of the luminaire. The "main beam direction" may be formed by one light source having a light emission direction or by the sum of a plurality of light emission directions each provided by a light source. Preferably, the "main beam direction" constitutes an axis, in particular a central axis, of a light cone provided by the luminaire.

[0007] In the context of the present invention, the term "driver" is to be understood as a means for the light source, in particular for an LED module, performing certain control functions, in particular controlling a current flowing through the light source, the LED module, respectively.

[0008] With other words, the present invention proposes to position the driver with respect to the heatsink and the light source such that a heat flow coming from the light source in the direction of the heatsink and of a rear side of the luminaire is pointing away from the driver. E.g., if the luminaire is attached to a ceiling, the driver is partially positioned below the light source and the heatsink, respectively, therefore affecting that the heat flow between the light source and the heatsink is pointing away from the driver. Thus, an excessive influence of the heat on the driver is avoided and the size as well as the material of the luminaire can be minimized, in particular with respect to luminaires having the same lumen output and the same ambient temperature performing with the same lifetime. As such, the driver is only influenced by the ambient air or ambient temperature rather than the heat generated by the light source.

[0009] The whole driver may be positioned on the side of the light source being opposite to the heatsink. By entirely positioning the driver on the side of the light source being opposite to the heatsink, the influence of heat generated by the light source acting on the driver is further reduced. This additionally provides an easy assembly of the luminaire, since both the light source and the driver can be assembled from the same side and in the same direction.

[0010] The luminaire may further comprise further electric and/or electronic components like an energy source, preferably a battery for emergency requirements, for operating the light source, wherein the further components are at least partially positioned on a side of the light source being opposite to the heatsink and more preferably also positioned on a side of the driver being opposite to the heatsink and the light source. Thus, the further components are not affected by the heat generated by the light source, either. This provides a more compact layout of the luminaire comprising the aforementioned components as well as an improved, i.e. longer, lifetime of the respective components and the luminaire as a whole. Moreover, positioning the further components on a side of the driver being opposite to the heatsink and the light source ensures that the temperature of the respective further component, e.g. the battery, is only influenced by the ambient temperature.

[0011] Preferably, the driver extends longitudinally with a longitudinal axis - i.e. has a longitudinal axis -, wherein the longitudinal axis is orientated substantially in parallel with respect to the main beam direction of the luminaire, and wherein the longitudinal axis of the driver is particularly preferably flush with the main beam direction of the luminaire. This arrangement is particularly advantageous for avoiding that heat from the light source is flowing to the driver. Moreover, due to the parallel and the preferred flush arrangement of the elongated driver with respect to the main beam direction, the influence of the driver on the light emission is improved, i.e. reduced, and the luminaire may be designed in a more compact manner.

[0012] Alternatively, the longitudinal axis of the driver may be angled and preferably orientated substantially perpendicular with respect to the main beam direction of the luminaire. Due to this arrangement, the luminaire may be decreased in size in an extending direction of the luminaire in the main beam direction.

[0013] Preferably, the driver is positioned at least partially within or outside the periphery of the heatsink, when viewed in the main beam direction of the luminaire. In other words, the driver is positioned at a position outside of an area defined by the light emission of the light source, so that the position does not affect the light emission of the light source. This is particularly advantageous for further reducing the influence of the driver on the light emission, wherein the size of the luminaire is further decreased in the extending direction of the luminaire in the direction of the main beam direction.

[0014] The heatsink may comprise a hole at least being open towards the light source, i.e. having an opening on the side of the light source, wherein the hole of the heatsink preferably tapers, e.g. in a stepwise manner, in a direction away from the light source.

[0015] Preferably, the luminaire further comprises a housing for enclosing and preferably holding the driver. Further preferably, the housing also encloses and particularly preferably holds the further components. This is particularly advantageous for easily mounting the respective components to the luminaire and for further avoiding that heat generated by the light source affects the components enclosed by the housing.

[0016] The housing may be mounted to the heatsink by means of a corresponding connection between the hole and the housing, wherein the corresponding connection is preferably a transition or press fit or provided by engagement of corresponding connection means of both the housing and the heatsink. The corresponding connection provides an easy way to mount the housing to the heatsink. In this context, a corresponding connection is to be understood as a connection between two elements, wherein the elements respectively comprise a connection element, e.g. the corresponding connection means, and wherein the connection element of the one element is formed correspondingly to the connection element of the other element, such that the elements can be securely connected with one another.

[0017] Furthermore, the housing may comprise an opening facing towards the heatsink, preferably the hole of the heatsink.

[0018] The housing may have a substantially cylindrical shape and/or tapers in a direction away from the heatsink, such that the widened end of the housing is preferably held within or by the hole of the heatsink, e.g. via the connection means. Further preferably, a rim of the housing is engaged with a connection groove of the heatsink preferably extending circumferentially in a step of the hole that tapers in a stepwise manner. The reception of the rim in the groove particularly improves the attachment of the housing on the heatsink.

[0019] Preferably, the outer surface of the housing comprises a plurality of cooling fins, particularly preferably evenly distributed over the circumference of the housing. The plurality of cooling fins increases the whole surface of the housing, thus increasing convection. Therefore, heat transfer from the components enclosed by the housing is increased.

[0020] Furthermore, the plurality of cooling fins may engage with the hole of the heatsink, e.g. by the connection means, and preferably about a step of the hole that tapers in a stepwise manner on the face side of the cooling fins. Further means for mounting the housing on the heatsink are thus reduced, since the cooling fins are simultaneously used as mounting elements.

[0021] The heatsink may comprise cooling fins, which are preferably evenly distributed over the circumference of the heatsink, wherein the cooling fins of the housing and the cooling fins of the heatsink preferably thermally cooperate with each other, e.g. by extending longitudinally from one another, to form a combined cooling body. Therefore, the surface of the heatsink and the housing is effectively increased, which is particularly advantageous for the cooling ability of the heatsink and the housing as well as the material used for said components.

[0022] Preferably, the heatsink comprises a receiving groove, e.g. a circumferentially extending receiving groove (e.g. extending around a symmetry axis of the luminaire), for receiving the light source. This is particularly advantageous for mounting the light source, thus reducing time and cost of assembly.

[0023] The light source may be an LED module, e.g. composed of at least one LED and/or printed circuit board. Preferably, the LED module is in plane contact with the heatsink. Said plane contact is particularly advantageous for effectively conducting heat from the LED module to the heatsink.

[0024] The luminaire may further comprise an optical system provided on the side of the light source being opposite to the heatsink for (optically) interacting with the light emitted by the light source, wherein the optical system is preferably connected to the heatsink, e.g. to cover or within the receiving groove. In particular, connecting the optical system to the heatsink further allows that heat of the optical system, that may come from the light source, is flowing to the heatsink.

[0025] The heatsink may comprise attaching elements for attaching the luminaire, e.g., at a ceiling or the like. Thus, the number of parts of the luminaire is reduced.

4. Description of a preferred embodiment

[0026] In the following, the invention is described exemplarily with reference to the enclosed figures, in which

Figure 1 is a schematic cross-sectional view of a preferred embodiment of the luminaire; and

Figure 2 the schematic cross-sectional of Figure 1

showing the temperature on air while the luminaire is operated.

[0027] Figure 1 is a cross-sectional view of the luminaire 10 according to a preferred embodiment of the invention. The luminaire 10 of the preferred embodiment is a luminaire for being operated with a high lumen output and/or in environments having a high ambient temperature. The luminaire 10 has a main beam direction B.

[0028] The luminaire 10 comprises a heatsink 1. In the preferred embodiment of Figure 1, the heatsink 1 has a substantially round and symmetrical shape. The heatsink 1 is, however, not restricted to a particular shape. Preferably, the heatsink 1 has such a shape that its surface is increased for facilitating heat flow. Increasing the surface of the heatsink may be achieved by (integrally) providing cooling fins 1g with the heatsink 1, which are preferably evenly distributed over the circumference of the heatsink 1. The cooling fins 1g may extend radially and may be arranged annularly with respect to the main beam direction B. Preferably, the cooling fins 1g constitute a lattice-like heatsink 1, thus providing an increased surface of the heatsink 1 for facilitating cooling.

[0029] The luminaire 10 further comprises a light source 2 mounted to the heatsink 1. As can be seen from Figure 1, the light source 2 is preferably mounted to the heatsink 1 by means of a receiving groove 1d that extends in the heatsink 1 preferably around the main beam direction B and receives the light source 2. Preferably, the receiving groove 1d extends in the plurality of cooling fins 1g. The cooling fins 1g preferably receive the light source 2. It should be noted that also other means for mounting the light source 2 are possible, such as by means of fixing elements or the like. The light source 2 may have a substantially two-dimensional extension. The light source 2 may be an LED module. The LED-module may be in plane contact with the heatsink 1. The LED module may comprise at least one LED and/or printed circuit board (PCB). Preferably, the at least one LED is bonded to the printed circuit board.

[0030] Furthermore, the luminaire 10 comprises a driver 3 configured to drive the light source 2. As can be seen by way of example of Figure 1, the whole driver 3 is positioned on the side of the light source 2 being opposite to the heatsink 1. However, it is already sufficient that the driver 3 is at least partially positioned on the side of the light source 2 being opposite to the heatsink 1 in order to achieve the inventive effect. Preferably, the light source 2 defines a plane and/or extends in a plane sandwiched between the heatsink 1 and the light emitting side, wherein the side of the light source 2 being opposite to the heatsink 1 faces towards the light emitting side. Under consideration of this plane, the driver 3 protrudes at least partially from the plane to the light emitting side. Preferably, the majority of the driver 3 is positioned on the side of the light source 2 being opposite to the heatsink 1. The majority may relate to, e.g., the volume of the driver 3, the weight of the driver 3 or the number of (electronic

and/or mechanical) components constituting the driver 3. The driver 3 may also be positioned with respect to the heatsink 1, such that (only) a part of the driver 3 being the most critical part of the driver 3 with respect to heat flow is positioned on the side of the light source 2 being opposite to the heatsink 1. Said part may be defined as the tc point. Even though not shown in Figures 1 and 2, further electric and/or electronic components such as an energy source, preferably a battery, and/or further means for controlling the light source 2, may be positioned with respect to the heatsink 1 in the same way as described previously for the driver 3. The further components may be positioned on a side of the driver 3 being opposite to the heatsink 1 and the light source 2, i.e. farther away from the heatsink 1 than the driver 3. In particular, the battery may be positioned farther away from the heatsink 1 than the driver 3, preferably below the driver 3. This ensures that the temperature of the battery is only influenced by the ambient temperature. Preferably, also the further components, respectively, may have a tc point, wherein said tc point is also positioned on the side of the light source 2 being opposite to the heatsink 1.

[0031] As can be seen in Figure 1, the driver 3 may extend longitudinally, preferably have an elongated shape, particularly preferably a cylindrical shape, with a longitudinal axis L, wherein the axis L is parallel or preferably flush with the main beam direction B of the luminaire 10. As can be seen in Figure 1, the axis L is substantially perpendicular to the plane defined by the light source 2. Alternatively the longitudinal axis L may also be angled and preferably orientated substantially perpendicular with respect to the main beam direction B, i.e. preferably substantially in parallel with respect to the plane defined by the light source 2. In addition, when viewed in the main beam direction B, i.e. from below in the direction of the light source 2 and heatsink 1 in Figure 1, the driver 3 may also be positioned at least partially within or outside the periphery of the heatsink 1.

[0032] The exemplary heatsink 1 of the luminaire 10 in Figure 10 further comprises a hole 1a having an opening on the side of the light source 2. Preferably, the hole 1a is positioned substantially in the center of the heatsink 1. The extending axis of the hole 1a may be parallel or preferably flush with the main beam direction B. In addition, the longitudinal axis L of the driver 3 may be parallel or preferably flush with the extending axis of the hole 1a. The driver 3 may extend in the hole 1a and may optionally be mounted to the heatsink 1 by means of the hole 1a. Preferably, the hole 1a has a tapering shape that tapers in a direction away from the light source 2 or the side of the light source 2 being opposite to the heatsink 1. As can be seen in Figure 1, tapering of the hole 1a may be constituted by a stepwise form of the hole 1a. The hole 1a may also be provided as a hole that tapers by gradually increasing its diameter or by partially increasing its diameter gradually and by partially increasing its diameter stepwisely. The latter option can be seen in Figure 1, where a first part of the hole 1a being on the side of the

light source 2 increases gradually, wherein the other part of the hole 1a is connected to the first part of the hole 1a via a step 1c. However, it is to be noted that step 1c can also be provided without the aforementioned form of the hole 1a.

[0033] As can be seen from Figure 1, the luminaire may comprise a housing 5 for enclosing and preferably holding the driver 3. Holding the driver 3 may be carried out by holding elements (not shown) provided in the housing 5. Preferably, the housing 5 is designed for further enclosing and optionally holding the further components, i.e. the energy source, e.g. a battery, and/or the further electronic and/or electric components. The housing 5 may be mounted to the heatsink 1 by means of a corresponding connection between the hole 1a and the housing 5, such as an engagement of corresponding connection means, a transition fit, a snap fit or the like. In addition or alternatively, the housing may be mounted to the heatsink 1 by means of fixing elements, such as bolts, nuts or the like. Preferably, the housing 5 comprises an opening 5a facing towards the heatsink 1. The opening 5a may face the hole 1a of the heatsink 1. Furthermore, the driver 3 may extend through the opening 5a into the hole 1a. In the preferred embodiment according to Figure 1, the housing 5 has a substantially cylindrical shape that tapers in a direction away from the heatsink 1, i.e. a substantially cone-shaped form. However, the housing may also have a different shape, such as a rectangular shape or the like. The end of the housing 5 facing towards the heatsink 1 may be held by the hole 1a of the heatsink 1. Said end may comprise a rim 5b that is preferably received by a connection groove 1b extending in the step 1c of the hole 1a. The connection groove 1b may further comprise engaging elements for engagement of the housing 5.

[0034] Furthermore, the housing 5 in Figure 1 comprises a plurality of cooling fins 5c. The cooling fins 5c may be evenly distributed over the circumference of the housing 5. The cooling fins 5c may extend from the opening 5b of the housing 5 in the extending direction of the housing 5, preferably away from the heatsink 1, substantially in the direction of the main beam direction B. As viewed perpendicular to the extending direction of the housing 5, the longitudinal axis L, respectively, the cooling fins 5c may be wedge-shaped. However, the cooling-fins 5c may also have any different shape, such as a rectangular shape or the like, that increases the total surface of the housing 5 for facilitating cooling of the components enclosed in the housing 5. The plurality of cooling fins 5c may engage with the hole 1a of the heatsink 1 for mounting the housing 5 on the heatsink 1. This arrangement also provides a heat flow from the housing 5 by way of the cooling fins 5c to the heatsink 1. Preferably, the hole 1a of the heatsink 1 comprises recesses 1e, in particular slots, corresponding to the shape and preferably to the number of the plurality of cooling fins 5c for engagement of the cooling fins 5c with the hole 1a. Furthermore, as can be seen in Figure 1, the cooling fins 5b may abut the

step 1c of the hole 1a on the face side of the cooling fins 5b. The cooling fins 1g of the heatsink 1 and the cooling fins 5c of the housing 5 may thermally cooperate with each other, e.g. by extending longitudinally from one another, to form a combined cooling body. As such, the housing 5 may also be integrally formed with the heatsink 1.

[0035] The material of the housing 5 and the cooling fins 5c, respectively, has a high thermal conductivity for facilitating cooling. Preferably, the material of the housing 5 is metal. The material of the heatsink 1 may also have a high thermal conductivity for facilitating cooling, such as metal or the like.

[0036] The luminaire 10 may further comprise an optical system 4 provided on the side of the light source 2 being opposite to the heatsink 1 for interacting with the light emitted by the light source 2. For instance, the optical system 2 may influence the emitted light to constitute the main beam direction B. For facilitating heat flow from the optical system 2 to the heatsink 1, the optical system 2 may be connected to, preferably mounted on, the heatsink 1. The optical system 4 may cover the receiving groove 1d, and thus preferably also covers the light source 2. As an alternative, the optical system 4 may also be provided/placed within the receiving groove 1d, i.e. the optical system 4 may be received by the receiving groove 1d and may cover the light source 2.

[0037] The heatsink 1 may comprise attaching elements for attaching the luminaire, e.g. at a housing, a ceiling, a wall etc. The attaching elements are preferably provided on a side of the heatsink 1 being opposite to the side of the heatsink 1, where the light source 2 is mounted.

[0038] Figure 2 shows the temperature on air while the luminaire 10 is operated. It is apparent that the heat plume H does not influence the temperature of the driver 3. The region inside the hole 1a constitutes a relatively hot region. Furthermore, it can be seen that heat generated by the light source 2 is flowing away from light source 2 by way of the heatsink 1 and further away from the heatsink 1.

[0039] It should be clear to a skilled person that the embodiment shown in the figures is only a preferred embodiment, but that, however, also other designs of a luminaire 10 having a heatsink 1, a light source 2 and a driver 3 can be used. In particular, the invention is not restricted to a particular form of the heatsink 1, the light source 2 and the driver 3.

Claims

1. A luminaire (10) having a main beam direction (B) comprising:
 - a heatsink (1),
 - a light source (2) mounted to the heatsink (1),
 - a driver (3) configured to drive the light source

- (2), wherein the driver (3) is at least partially positioned on a side of the light source (2) being opposite to the heatsink (1), and
-
- a) further electric and/or electronic components for operating the light source (2), **characterized in that** the further components are at least partially positioned on a side of the light source (2) being opposite to the heatsink (1) and
- b) also positioned on a side of the driver (3) being opposite to the heatsink (1) and the light source (2).
2. The luminaire (10) according to claim 1, wherein the whole driver (3) is positioned on the side of the light source (2) being opposite to the heatsink (1).
 3. The luminaire (10) according to any one of the preceding claims, wherein the further electric and/or electronic components comprise an energy source, preferably a battery, for operating the light source (2).
 4. The luminaire (10) according to any one of the preceding claims, wherein the driver (3) extends longitudinally with a longitudinal axis (L), wherein the longitudinal axis (L) is orientated substantially in parallel with respect to the main beam direction (B) of the luminaire (10), and wherein the longitudinal axis (L) of the driver (3) is preferably flush with the main beam direction (B) of the luminaire (10), or the driver (3) extends longitudinally with a longitudinal axis (L), wherein the longitudinal axis (L) is angled and preferably orientated substantially perpendicular with respect to the main beam direction (B) of the luminaire (10).
 5. The luminaire (10) according to any one of the preceding claims, wherein the driver (3) is positioned at least partially within or outside the periphery of the heatsink (1), when viewed in the main beam direction (B) of the luminaire (10).
 6. The luminaire (10) according to any one of the preceding claims, wherein the heatsink (1) comprises a hole (1a) at least being open towards the light source (2), wherein the hole (1a) of the heatsink (1) preferably tapers, e.g. in a stepwise manner, in a direction away from the light source (2).
 7. The luminaire (10) according to any one of the preceding claims further comprising a housing (5) for enclosing and preferably holding the driver (3) and preferably also the further components, wherein the housing (5) is mounted to the heatsink (1) preferably by means of a corresponding connection particularly preferably between the hole (1a) and the housing (5), wherein the corresponding connection is preferably a transition fit or provided by engagement of corresponding connection means of both the housing (5) and the heatsink (1).
 8. The luminaire (10) according to claim 7, wherein the housing (5) comprises an opening (5a) facing towards the heatsink (1), preferably the hole (1a) of the heatsink (1).
 9. The luminaire (10) according to claim 7 or 8, wherein the housing (5) has a substantially cylindrical shape and/or tapers in a direction away from the heatsink (1), such that the widened end of the housing (5) is preferably held within the hole (1a) of the heatsink (1), e.g. via the connection means, wherein a rim (5b) of the housing (5) is preferably engaged with a connection groove (1b) of the heatsink (1) preferably extending circumferentially in a step (1c) of the hole (1) tapering in a stepwise manner.
 10. The luminaire (10) according to any one of claims 7 to 9, wherein the outer surface of the housing (5) comprises a plurality of cooling fins (5c), preferably evenly distributed over the circumference of the housing (5), wherein the plurality of cooling fins (5c) preferably engage with the hole (1a) of the heatsink (1), e.g. by the connection means, and particularly preferably about a step (1c) of the hole (1a) tapering in a stepwise manner on the face side of the cooling fins.
 11. The luminaire (10) according to any one of the preceding claims, wherein the heatsink comprises cooling fins which are preferably evenly distributed over the circumference of the heatsink, and wherein the cooling fins of the housing and the cooling fins of the heatsink preferably thermally cooperate with each other, e.g. by extending longitudinally from one another, to form a combined cooling body.
 12. The luminaire (10) according to any one of the preceding claims, wherein the heatsink (1) comprises a receiving groove (1d), e.g. a circumferentially extending receiving groove, for receiving the light source (2),
 13. The luminaire (10) according to any one of the preceding claims, wherein the light source (2) is an LED module preferably being in plane contact with the heatsink (1).
 14. The luminaire (10) according to any one of the preceding claims further comprising an optical system (4) provided on the side of the light source (2) being opposite to the heatsink (1) for interacting with the light emitted by the light source (2), wherein the op-

tical system (4) is preferably connected to the heat-sink (1), e.g. to cover or within the receiving groove (1d).

15. The luminaire (10) according to any one of the preceding claims, wherein the heatsink (1) comprises attaching portions or elements (1f) for attaching the luminaire.

Patentansprüche

1. Leuchte (10) mit einer Hauptstrahlrichtung (B), umfassend:

- eine Wärmesenke (1),
- eine Lichtquelle (2), die auf die Wärmesenke (i) montiert ist,
- einen Treiber (3), der konfiguriert ist, um die Lichtquelle (2) zu treiben, wobei der Treiber (3) mindestens teilweise auf einer Seite der Lichtquelle (2) positioniert ist, die sich gegenüber der Wärmesenke (1) befindet, und
- a) weitere elektrische und/oder elektronische Komponenten, um die Lichtquelle (2) zu betreiben, **dadurch gekennzeichnet, dass** die weiteren Komponenten mindestens teilweise auf einer Seite der Lichtquelle (2) positioniert sind, die sich gegenüber der Wärmesenke (1) befindet, und
- b) auch auf einer Seite des Treibers (3) positioniert ist, die sich gegenüber der Wärmesenke (1) und der Lichtquelle (2) befindet.

2. Leuchte (10) nach Anspruch 1, wobei der gesamte Treiber (3) auf der Seite der Lichtquelle (2) positioniert ist, die sich gegenüber der Wärmesenke (1) befindet.

3. Leuchte (10) nach einem der vorhergehenden Ansprüche, wobei die weiteren elektrischen und/oder elektronischen Komponenten eine Energiequelle umfassen, vorzugsweise eine Batterie, um die Lichtquelle (2) zu betreiben.

4. Leuchte (10) nach einem der vorhergehenden Ansprüche, wobei sich der Treiber (3) längs mit einer Längsachse (L) erstreckt, wobei die Längsachse (L) im Wesentlichen parallel mit Bezug auf die Hauptstrahlrichtung (B) der Leuchte (10) ausgerichtet ist, und wobei die Längsachse (L) des Treibers (3) vorzugsweise bündig mit der Hauptstrahlrichtung (B) der Leuchte (10) ist oder sich der Treiber (3) längs mit einer Längsachse (L) erstreckt, wobei die Längsachse (L) gewinkelt und im Wesentlichen senkrecht mit Bezug auf die Hauptstrahlrichtung (B) der Leuchte (10) ausgerichtet ist.

5. Leuchte (10) nach einem der vorhergehenden Ansprüche, wobei der Treiber (3) mindestens teilweise innerhalb oder außerhalb des Umfangs der Wärmesenke (1) positioniert ist, wenn er in der Hauptstrahlrichtung (B) der Leuchte (10) betrachtet wird.

6. Leuchte (10) nach einem der vorhergehenden Ansprüche, wobei die Wärmesenke (1) ein Loch (1a) umfasst, das mindestens hin zur Lichtquelle (2) offen ist, wobei das Loch (1a) der Wärmesenke (1) sich vorzugsweise verjüngt, d. h. schrittweise in einer Richtung weg von der Lichtquelle (2).

7. Leuchte (10) nach einem der vorhergehenden Ansprüche, weiter umfassend ein Gehäuse (5) zum Einschließen und vorzugsweise Halten des Treibers (3) und vorzugsweise auch der weiteren Komponenten, wobei das Gehäuse (5) auf die Wärmesenke (1) vorzugsweise mit Hilfe einer entsprechenden Verbindung montiert ist, besonders bevorzugt zwischen dem Loch (1a) und dem Gehäuse (5), wobei die entsprechende Verbindung vorzugsweise ein Übergang ist, der durch Eingreifen von entsprechenden Verbindungsmitteln sowohl des Gehäuses (5) als auch der Wärmesenke (1) angepasst oder bereitgestellt ist.

8. Leuchte (10) nach Anspruch 7, wobei das Gehäuse (5) eine Öffnung (5a) umfasst, die hin zur Wärmesenke (1), vorzugsweise dem Loch (1a) der Wärmesenke (1) gerichtet ist.

9. Leuchte (10) nach Anspruch 7 oder 8, wobei das Gehäuse (5) eine im Wesentlichen zylindrische Form aufweist und/oder sich in einer Richtung weg von der Wärmesenke (1) verjüngt, so dass das ausgeweitete Ende des Gehäuses (5) vorzugsweise innerhalb des Lochs (1a) der Wärmesenke (1) gehalten wird, z. B. mit Hilfe der Verbindungsmittel, wobei ein Rand (5b) des Gehäuses (5) vorzugsweise mit einer Verbindungsnut (1b) der Wärmesenke (1) eingegriffen ist, die sich vorzugsweise umfänglich in einem Schritt (1c) des Lochs (1) erstreckt, das sich schrittweise verjüngt.

10. Leuchte (10) nach einem der Ansprüche 7 bis 9, wobei die äußere Fläche des Gehäuses (5) eine Vielzahl von Kühl lamellen (5c) umfasst, die vorzugsweise gleichmäßig über den Umfang des Gehäuses (5) verteilt sind, wobei die Vielzahl von Kühl lamellen (5c) vorzugsweise mit dem Loch (1a) der Wärmesenke (1) eingreift, z. B. durch die Verbindungsmittel, und besonders vorzugsweise an einen Schritt (1c) des Lochs (1a) anstößt, der sich schrittweise auf der Vorderseite der Kühl lamellen verjüngt.

11. Leuchte (10) nach einem der vorhergehenden Ansprüche, wobei die Wärmesenke Kühl lamellen um-

fasst, die vorzugsweise gleichmäßig über den Umfang der Wärmesenke verteilt sind, und wobei die Kühllamellen des Gehäuses und die Kühllamellen der Wärmesenke vorzugsweise thermisch miteinander zusammenarbeiten, z. B. indem sie sich längs voneinander erstrecken, um einen kombinierten Kühlkörper zu bilden.

12. Leuchte (10) nach einem der vorhergehenden Ansprüche, wobei die Wärmesenke (1) eine Aufnahme (1d) umfasst, z. B. eine sich umfänglich erstreckende Aufnahme, um die Lichtquelle (2) aufzunehmen.
13. Leuchte (10) nach einem der vorhergehenden Ansprüche, wobei die Lichtquelle (2) ein LED-Modul ist, das vorzugsweise in ebenem Kontakt mit der Wärmesenke (1) ist.
14. Leuchte (10) nach einem der vorhergehenden Ansprüche, weiter umfassend ein optisches System (4), das auf der Seite der Lichtquelle (2) bereitgestellt ist, die sich gegenüber der Wärmesenke (1) befindet, um mit dem Licht, emittiert von der Lichtquelle (2), zu interagieren, wobei das optische System (4) vorzugsweise mit der Wärmesenke (1) verbunden ist, z. B. um abzudecken innerhalb Aufnahme (1d).
15. Leuchte (10) nach einem der vorhergehenden Ansprüche, wobei die Wärmesenke (1) Befestigungsabschnitte oder Elemente (1f) umfasst, um die Leuchte (10) zu befestigen.

Revendications

1. Luminaire (10) ayant une direction de faisceau principale (B) comprenant :
 - un dissipateur thermique (1),
 - une source de lumière (2) montée sur le dissipateur thermique (1),
 - un excitateur (3) configuré pour exciter la source de lumière (2), dans lequel l'excitateur (3) est au moins partiellement positionné sur un côté de la source de lumière (2) à l'opposé du dissipateur thermique (1), et
 - - a) d'autres composants électriques et/ou électroniques pour actionner la source de lumière (2),
 - caractérisé en ce que** les autres composants sont au moins partiellement positionnés sur un côté de la source de lumière (2) à l'opposé du dissipateur thermique (1) et
 - b) également positionnés sur un côté de l'excitateur (3) à l'opposé du dissipateur

thermique (1) et de la source de lumière (2) .

2. Luminaire (10) selon la revendication 1, dans lequel l'excitateur complet (3) est positionné sur le côté de la source de lumière (2) à l'opposé du dissipateur thermique (1).
3. Luminaire (10) selon l'une quelconque des revendications précédentes, dans lequel les autres composants électriques et/ou électroniques comprennent une source d'énergie, de préférence une batterie, pour assurer le fonctionnement de la source de lumière (2).
4. Luminaire (10) selon l'une quelconque des revendications précédentes, dans lequel l'excitateur (3) s'étend longitudinalement avec un axe longitudinal (L), dans lequel l'axe longitudinal (L) est orienté sensiblement en parallèle par rapport à la direction de faisceau principale (B) du luminaire (10), et dans lequel l'axe longitudinal (L) de l'excitateur (3) est de préférence au même niveau que la direction de faisceau principale (B) du luminaire (10), ou l'excitateur (3) s'étend longitudinalement avec un axe longitudinal (L), dans lequel l'axe longitudinal (L) est incliné et de préférence orienté sensiblement perpendiculairement à la direction de faisceau principale (B) du luminaire (10).
5. Luminaire (10) selon l'une quelconque des revendications précédentes, dans lequel l'excitateur (3) est positionné au moins partiellement à l'intérieur ou à l'extérieur de la périphérie du dissipateur thermique (1), lorsqu'il est vu dans la direction de faisceau principale (B) du luminaire (10).
6. Luminaire (10) selon l'une quelconque des revendications précédentes, dans lequel le dissipateur thermique (1) comprend un orifice (1a) au moins ouvert vers la source de lumière (2), dans lequel l'orifice (1a) du dissipateur thermique (1) se rétrécit de préférence, par exemple de manière progressive, dans une direction s'éloignant de la source de lumière (2).
7. Luminaire (10) selon l'une quelconque des revendications précédentes comprenant en outre un logement (5) pour enfermer et de préférence maintenir l'excitateur (3) et de préférence également les autres composants, dans lequel le logement (5) est monté sur le dissipateur thermique (1) de préférence au moyen d'une liaison correspondante en particulier de préférence entre l'orifice (1a) et le logement (5), dans lequel la liaison correspondante est de préférence un ajustement incertain ou assurée par la mise en prise des moyens de liaison correspondants à la fois du logement (5) et du dissipateur thermique (1).
8. Luminaire (10) selon la revendication 7, dans lequel

le logement (5) comprend une ouverture (5a) orientée vers le dissipateur thermique (1), de préférence l'orifice (1a) du dissipateur thermique (1).

9. Luminaire (10) selon la revendication 7 ou 8, dans lequel le logement (5) a une forme sensiblement cylindrique et/ou se rétrécit dans une direction s'éloignant du dissipateur thermique (1), de telle sorte que l'extrémité élargie du logement (5) est de préférence maintenue à l'intérieur de l'orifice (1a) du dissipateur thermique (1), par exemple via les moyens de liaison, dans lequel un rebord (5b) du logement (5) est de préférence mis en prise avec une rainure de liaison (1b) du dissipateur thermique (1) s'étendant de préférence circonférentiellement dans un gradin (1c) de l'orifice (1) se rétrécissant de manière progressive. 5 10 15
10. Luminaire (10) selon l'une quelconque des revendications 7 à 9, dans lequel la surface externe du logement (5) comprend une pluralité d'ailettes de refroidissement (5c), de préférence réparties de manière uniforme sur la circonférence du logement (5), dans lequel la pluralité d'ailettes de refroidissement (5c) se mettent en prise de préférence avec l'orifice (1a) du dissipateur thermique (1), par exemple à l'aide des moyens de liaison, et en particulier de préférence viennent en butée contre un gradin (1c) de l'orifice (1a) se rétrécissant de manière progressive sur le côté face des ailettes de refroidissement. 20 25 30
11. Luminaire (10) selon l'une quelconque des revendications précédentes, dans lequel le dissipateur thermique comprend des ailettes de refroidissement qui sont de préférence réparties de manière uniforme sur la circonférence du dissipateur thermique, et dans lequel les ailettes de refroidissement du logement et les ailettes de refroidissement du dissipateur thermique coopèrent de préférence thermiquement les unes avec les autres, par exemple en s'étendant longitudinalement les unes par rapport aux autres, pour former un corps de refroidissement combiné. 35 40
12. Luminaire (10) selon l'une quelconque des revendications précédentes, dans lequel le dissipateur thermique (1) comprend une rainure réceptrice (1d), par exemple une rainure réceptrice s'étendant circonférentiellement, pour recevoir la source de lumière (2). 45
13. Luminaire (10) selon l'une quelconque des revendications précédentes, dans lequel la source de lumière (2) est un module à DEL étant de préférence en contact plan avec le dissipateur thermique (1). 50
14. Luminaire (10) selon l'une quelconque des revendications précédentes comprenant en outre un système optique (4) prévu sur le côté de la source de lumière (2) à l'opposé du dissipateur thermique (1) 55

pour interagir avec la lumière émise par la source de lumière (2), dans lequel le système optique (4) est de préférence relié au dissipateur thermique (1), par exemple, au couvercle ou à l'intérieur de la rainure réceptrice (1d).

15. Luminaire (10) selon l'une quelconque des revendications précédentes, dans lequel le dissipateur thermique (1) comprend des parties ou éléments de fixation (1f) pour fixer le luminaire.

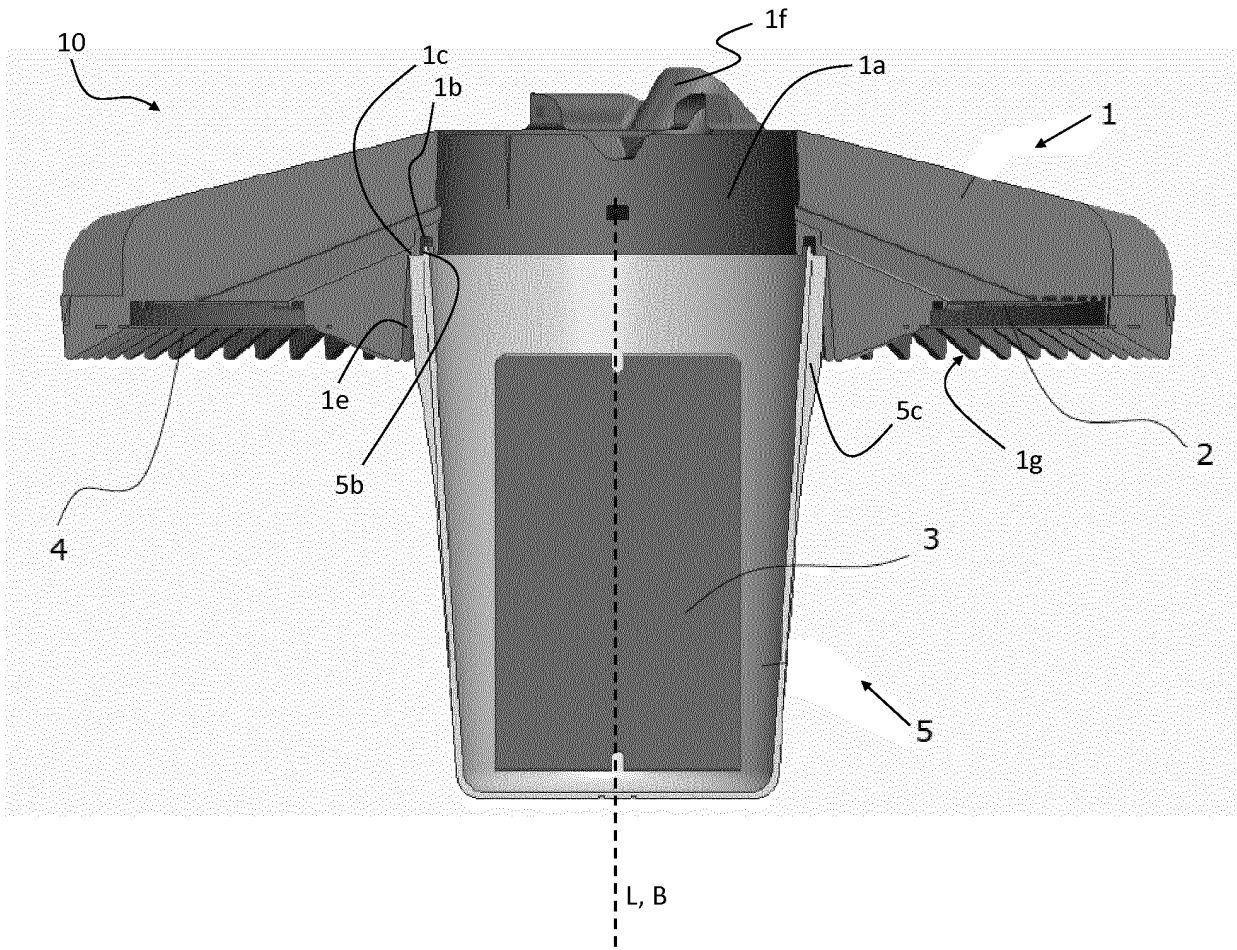

Figure 1

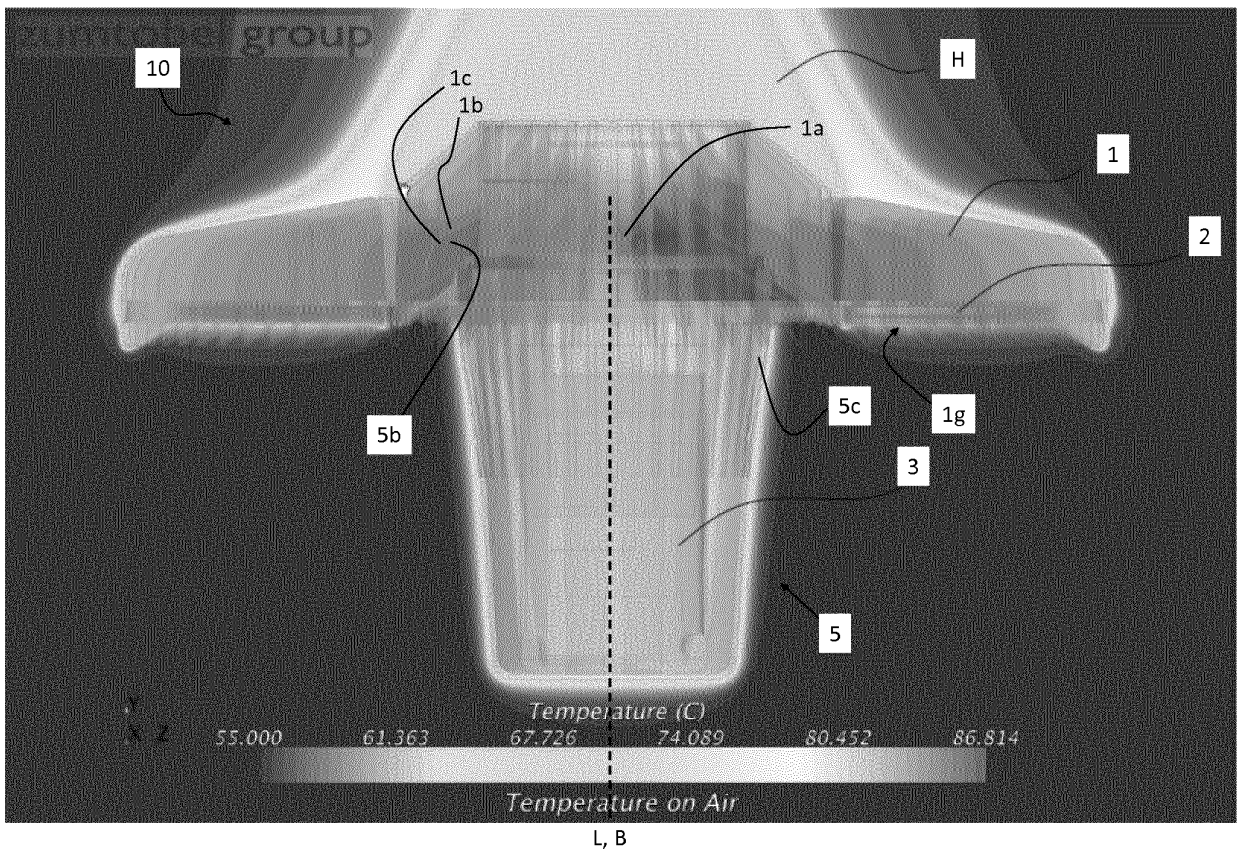

Figure 2

REFERENCES CITED IN THE DESCRIPTION

This list of references cited by the applicant is for the reader's convenience only. It does not form part of the European patent document. Even though great care has been taken in compiling the references, errors or omissions cannot be excluded and the EPO disclaims all liability in this regard.

Patent documents cited in the description

- US 20130044478 A [0003]