

Aug. 19, 1930.

W. E. SIMMONS

1,773,635

MOTOR

Filed July 2, 1925

4 Sheets-Sheet 1

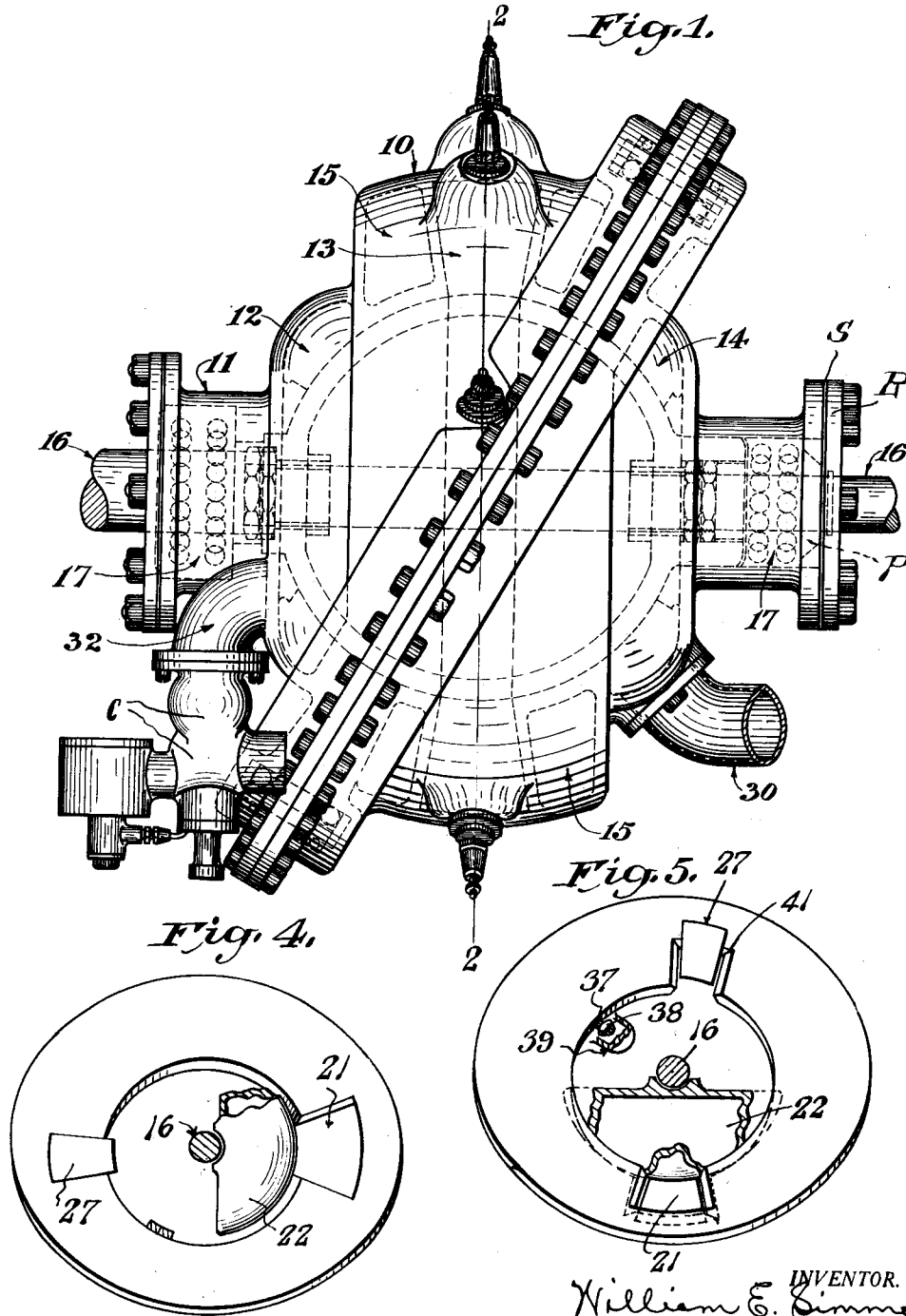

Fig. 5.

Fig. 4.

INVENTOR.  
William E. Simmons  
BY  
J. B. Stodges  
ATTORNEYS

Aug. 19, 1930.

W. E. SIMMONS

1,773,635

MOTOR

Filed July 2, 1925

4 Sheets-Sheet 2

Fig. 2

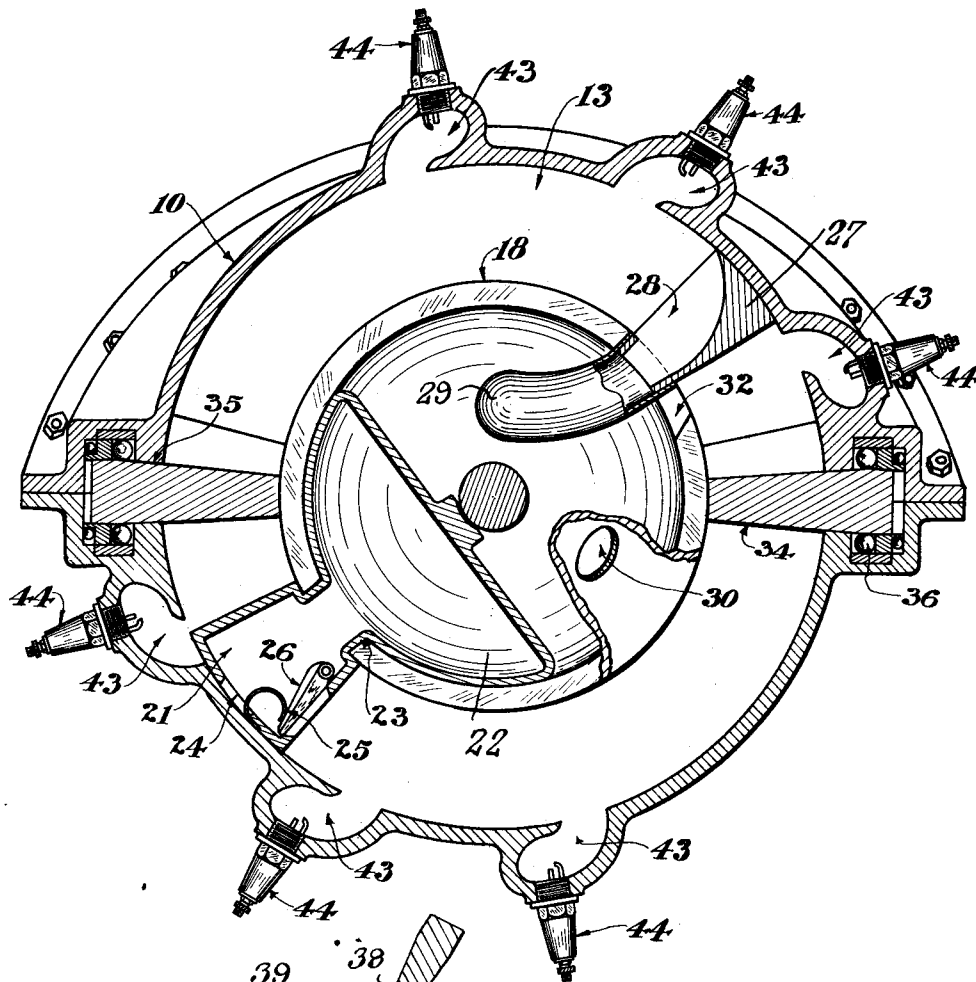
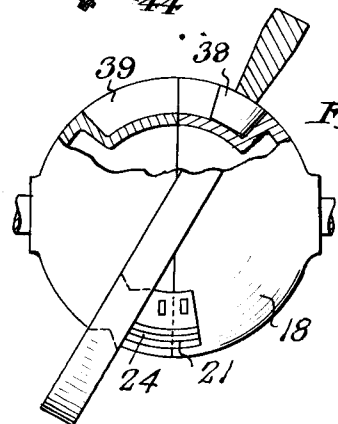

Fig. 8.



INVENTOR.  
William E. Simmons  
BY *Wm. S. Dodge*  
ATTORNEYS

Aug. 19, 1930.

W. E. SIMMONS

1,773,635

MOTOR

Filed July 2, 1925

4 Sheets-Sheet 3

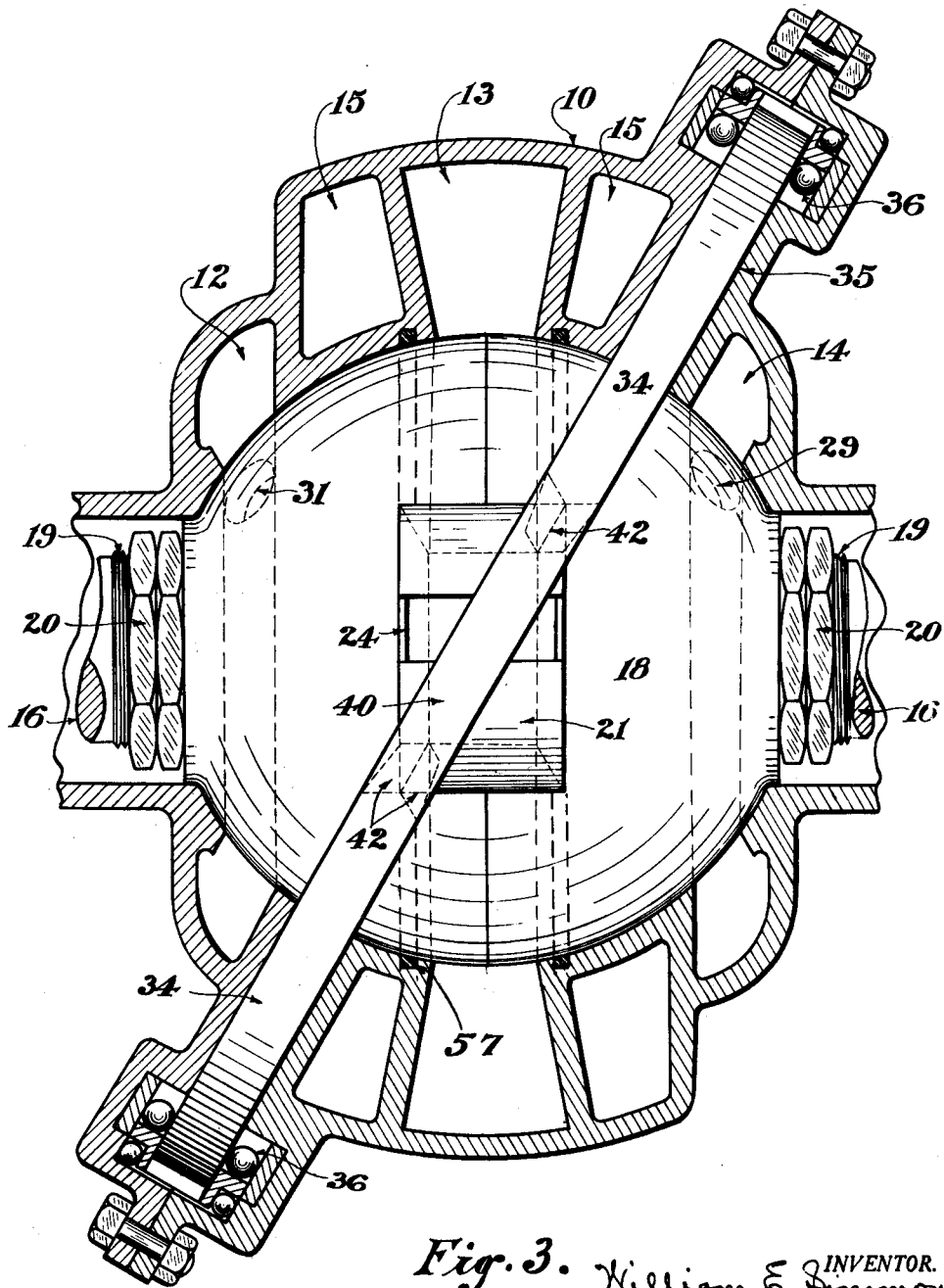

Fig. 3. *William E. Simmons* INVENTOR.

BY *Wm. S. Dodge* ATTORNEYS.

Aug. 19, 1930.

W. E. SIMMONS

1,773,635

MOTOR

Filed July 2, 1925

4 Sheets-Sheet 4

Fig. 9.

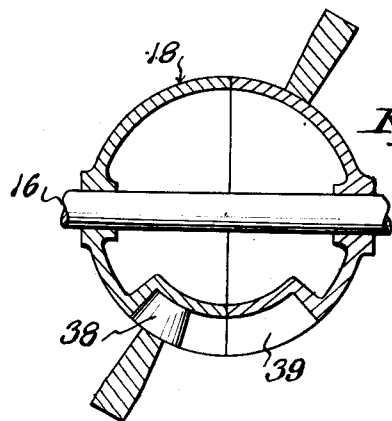
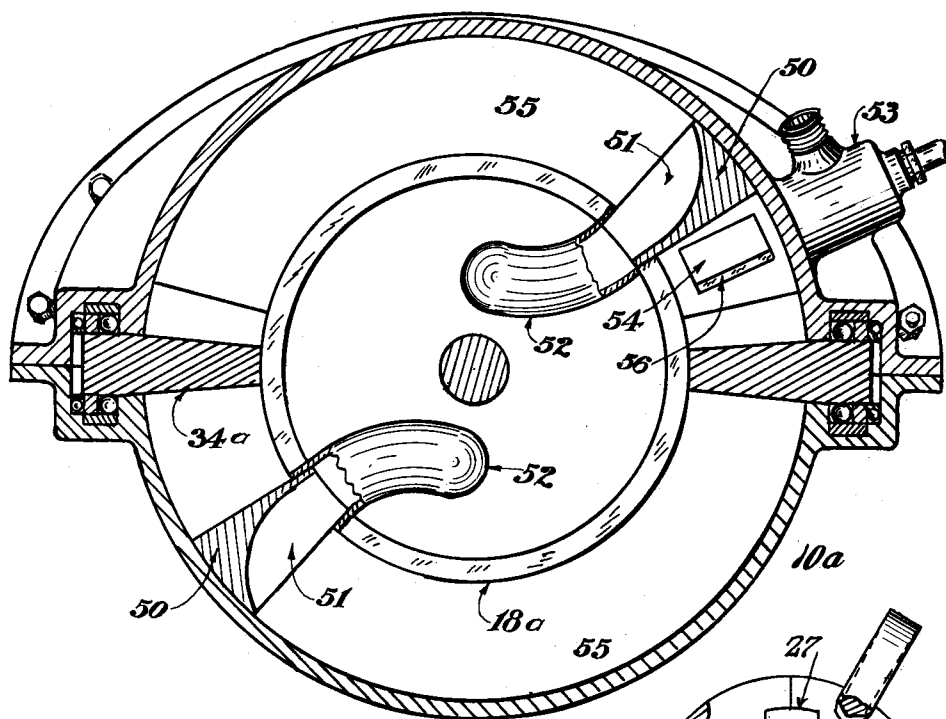

Fig. 6.

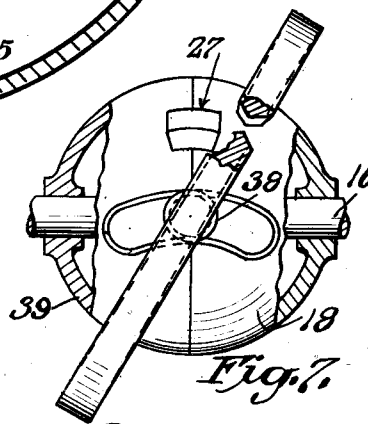

Fig. 7.

WILLIAM E. SIMMONS, INVENTOR.  
BY *James H. Dodge* ATTORNEYS

# UNITED STATES PATENT OFFICE

WILLIAM E. SIMMONS, OF OCALA, FLORIDA, ASSIGNOR TO MECHANICAL IMPROVEMENT CORPORATION, OF OCALA, FLORIDA, A CORPORATION OF FLORIDA

## MOTOR

Application filed July 2, 1925. Serial No. 41,086.

This invention is a prime mover of the rotary type.

One of the objects of the invention is to provide an engine capable of being actuated by gas, steam, or other expansive fluids, flowing liquids, heat or air. A further object is to provide a motor, the number of moving parts of which are so minimized and so balanced, that in operation, reciprocations and vibrations are practically eliminated. A further object is to provide a motor of the character mentioned, provided with two major moving parts, namely, a substantially spherical rotor to which the impelling force is applied, and a revoluble abutment disk movable synchronously with the rotor, but on an axis of rotation which is at an angle to the axis of rotation of the rotor. A further object is to provide simple means whereby rotation is imparted to the abutment disk through the medium of the spherical rotor. A further object is to provide a motor of the character referred to, in which the spherical rotor is mounted within a casing having supply and exhaust chambers, the surface of the rotor being so disposed as to form one wall of each of said chambers. A further object is to provide a casing for the rotor which is provided with an annular chamber or cylinder in which the power and scavenger pistons rotate. A further object is to provide a casing having an annular chamber so located as to receive the valve disk and permit its rotation. A further object is to provide improved means for receiving an explosive or impelling mixture and timing the compression and delivery of the charge to be fired. A further object is to provide a motor of the character mentioned, having a piston of simple construction provided with a storage chamber for compressed explosive mixture, and so constructed as to successively deliver charges of said compressed mixture into the firing chambers.

The invention will be hereinafter fully set forth and particularly pointed out in the claims.

In the accompanying drawings:—

Figure 1 is a front elevation of a motor constructed in accordance with the inven-

tion. Figure 2 is a vertical sectional view on the line 2—2, Figure 1. Figure 3 is a sectional view taken at approximately right angles to Figure 2. Figures 4 and 5 are detail views of the abutment disk viewed from opposite sides. Figures 6, 7 and 8 are diagrammatic views illustrating the operative relation of the rotor and the abutment disk. Figure 9 is a sectional view illustrating a slight modification, designed as a steam or air motor.

Referring to the drawings, 10 designates a casing which may be of any suitable design, but as shown is of general cylindrical shape, provided with laterally disposed tubular branches 11. The interior of the casing is provided with a central chamber to receive an approximately spherical body. The casing is provided with an intake chamber 12, a piston chamber 13, and an exhaust chamber 14, said intake and exhaust chambers being preferably located on opposite sides of said piston chamber. Suitable cooling means is provided, such as water cooled chambers indicated at 15.

Extending transversely through and diametrically across the internal chamber of the casing 10 is an engine shaft 16, mounted in suitable bearings 17, located within the extensions 11. Mounted on said shaft so as to rotate therewith is a hollow rotor 18, which consists of an approximately spherical shell constructed in two parts, and provided with axial openings through which the shaft 16 extends. Said shaft is provided with threaded portions 19, engaged by nuts 20, which serve to maintain the two sections of the rotor in abutted relation. The surface of the rotor 18 is so positioned within the casing as to act as one wall for each of the chambers 12, 13 and 14, respectively. Shims S, located between the ends of the branches 11 and collars R, attached to said ends, are provided to maintain proper thrust adjustments to insure revolution of the rotor without undue friction on the casing walls. Suitable packing rings P are also provided.

Projecting radially from the surface of the rotor 18 is the power piston 21, which is of a cross section to fill the piston chamber 13.

Said piston consists of a hollow, box-like body communicating with an explosive mixture storage chamber 22, located within the hollow rotor 18, and communicating with the piston through a neck 23. The piston is provided with a discharge port 24 in its outer wall, and its front wall is provided with inlet openings normally closed by spring pressed valves 26. The tension of the springs is such as to maintain the valves 26 closed against the action of centrifugal force tending to open them.

The exhaust or scavenging piston 27 also projects from the surface of the spherical rotor into the piston chamber 13, at a position opposite to that of the power piston 21. Said exhaust piston is provided with a channel-like outlet 28, which communicates with the conduit 29, leading through the interior of the rotor 18, and discharging into the exhaust chamber 14 through a suitable opening. Said chamber is also provided with an exhaust pipe 30.

Explosive mixture is introduced by means of a carbureter C, communicating with the intake chamber 12, and passes thence into the interior of the rotor through an opening 31. From the chamber 12 the mixture passes into the piston chamber through an opening 32 located in the wall of the rotor directly back of the scavenging piston 27. It is to be understood that although the parts just described are designed to operate as an explosive engine, the invention is not limited to this particular method of operation, but may be driven by various other impelling forces without departing from the spirit of the invention.

The abutment disk 34 consists of an approximately flat circular body provided with a central opening to receive the rotor 18, the faces of said disk being arranged on radial lines to produce a somewhat wedge-shape in cross section.

In practice, the disk 34 encloses the rotor 18, the axis of rotation of the disk being disposed at an angle to the axis of rotation of the rotor. Any desired angular relation of these parts may be adopted, but for purposes of illustration the disk is shown as arranged at an approximate angle of 30° to the vertical median line of the rotor.

The disk is rotatably mounted on the rotor 18 as an axis, within a circular chamber 36. Any suitable anti-friction means may be provided to take care of the friction due to pressures which tend to force the disk out of alinement. For purposes of illustration anti-friction bearings 36 are shown engaging the faces of the disk near its periphery. Projecting inwardly from the edge of the opening in the disk 34, in a radial position, is a stud 37, on which is revolvably mounted a roller 38, located within a curved groove 39, formed in the surface of the rotor

18. Said disk is also provided with a transverse opening 40 for the passage of the power piston 21, and an oppositely positioned opening 41 for the passage of the exhaust piston 27. Referring particularly to Figure 3 of the drawings, it will be noted that the radial walls of the openings 40 and 41 are provided with angular faces 42, so disposed as to maintain the proper angular relation between each piston and its respective opening, as the piston crosses the line of travel of the disk during operation of the motor.

Surrounding the piston chamber 13, and communicating therewith, are a plurality of firing chambers 43, each provided with a suitable ignition device, such as a spark plug 44. The walls of said firing chambers are so shaped that the force of each explosion is directed into the chamber 13 in an approximately tangential line, and diagonally against the piston 21, so as to secure the maximum impelling effect upon said piston. It is to be understood that a suitable timing and ignition system is to be employed, but as they form no part of the present invention it is not considered necessary to show or describe them.

In operation, when the motor is initially cranked, the rotor 18 is rotated with the shaft 16, and an explosive mixture from the carbureter is drawn into the chamber 12, and from thence through the rotor 18 and opening 32 into the piston chamber 13. The necessary suction is created by movement of the scavenger piston 27, and that portion of the ring 34 which lies back of the piston. As the piston 21, passing through the disk 34, enters the mixture filled portion of the chamber 13, the piston 27 passes into the other half of said chamber, the disk 34 serving to prevent leakage after the pistons pass. As the piston 21 travels it cooperates with the disk 34 to compress the explosive mixture lying ahead of the piston, and as the compression builds up the valves 26 are unseated, and the compressed mixture is forced into and stored within the chamber 22. After the mixture-filled piston 21 passes the abutment disk 34, the discharge opening 24 directs charges of the explosive mixture successively into the respective firing chambers 43, and each charge is fired by the ignition device after the ports in the piston and the firing chamber have passed each other. This allows several degrees of advance sparking before the rear wall of the piston passes the openings in the respective firing chambers. From this time on, the compressing and firing operations are continuous, the mixture being first compressed and stored within the piston and the storage chamber 22, and then discharged into the firing chambers and exploded. The piston 27 always operates to draw into the chamber 13 a sufficient volume of explosive mixture to insure these operations. In addition

to providing the suction to draw in the explosive mixture, the piston 27 also serves to scavenge the chamber 13 after each series of explosions, the products of combustion passing into the channel 28, and thence to the exhaust pipe.

It will be noted that revolution of the rotor 18 by means of the explosions against piston 21, will cause said rotor to turn with and drive the shaft 16. Rotation of the disk 34 is effected by reason of the engagement of the pin 37 and the roller 38 of the disk, projecting into the groove 39. The relative positions of the parts through a complete revolution are indicated in Figures 4, 5, 6 and 7. Assuming arbitrarily that the parts are in the positions shown in Figure 6, when the rotor has travelled 90° the parts are positioned as shown in Figure 7, and after the rotor moves an additional 90° with respect to Figure 6, they assume the positions of Figure 8. The parts are so proportioned and timed that the opening 40 in the disk 34 presents itself in proper position to allow the piston 21 to pass therethrough, the angular faces 42 of the walls of the opening compensating for the difference in the direction of travel of the two parts and maintaining satisfactory joints. The same is true with respect to the piston 27 and the opening 41.

In Figure 9 the invention is illustrated in a form to be operated by steam or other expansive fluid. Referring to said figure, the casing 10<sup>a</sup>, spherical rotor 18<sup>a</sup> and abutment disk 34<sup>a</sup> are the same as the corresponding parts illustrated in the other figures. Secured to and projecting from the face of the rotor are two or more pistons 50, each provided in its front face with an exhaust channel 51 communicating with a pipe 52, leading through the rotor to a suitable exhaust chamber. Steam or other expansive fluid is introduced by means of a suitable supply system, indicated at 53, into a steam chamber 54, and from thence into the piston chamber 55, through an opening 56. The expansion of said fluid against the piston and the abutment disk 34<sup>a</sup>, impels the rotor, the exhaust steam lying ahead of each piston being conducted off through the channel 51 and the pipe 52.

The advantages of the invention will be readily apparent to those skilled in the art to which it belongs. It will be particularly noted that a high powered rotary motor is provided, constructed of a minimum number of parts, which are so balanced that the operation is practically vibrationless. The relation of the parts is such that introduction of the impelling force is perfectly timed and maximum power is provided with minimum losses due to friction and leakage. By mounting the abutment disk eccentrically with respect to the axis of rotation of the rotor, the piston chamber is practically divided into two

parts, thereby performing the functions of two chambers, while the pistons are within the piston gates of the disk. At all other positions of the pistons, the disk, by reason of its angular position, divides the chamber 13 into two parts, and the pistons divide into two parts, each of the divisions produced by the disk. Thus, the piston chamber is divided into four separate chambers, in each of which one cycle of the four cycle gas engine principle is being performed. By utilizing the spherical rotor to provide the inner walls of the intake, exhaust and piston chambers, respectively, the number of structural parts is materially reduced. Another very important advantage of the spherical shape of the rotor is that a nice valve fit for the abutment disk is obtained, so that the central opening in said disk is always filled by the rotor, no matter at what angle the disk may lie with respect to the normal axis of rotation of the rotor. An important advantage is also obtained by making the piston hollow and providing the inlet in the front face and the outlet in the top. By means of this arrangement, the explosive mixture which is compressed in front of the piston is directed into the storage chamber within the rotor, the piston serving as a portion of said storage chamber, and the mixture is retained within said chamber until it can be passed out of the top and be bypassed into the space back of the piston to be exploded. Thus, a reserve volume of explosive mixture is always maintained, the vaporization of the mixture reaches the highest attainable degree of perfection, and the compression obtainable at ignition is very little less than the peak compression pressure.

While the invention has been described as a prime mover operated by an impelling force, it is not limited to this particular because it may be used as a rotary pump or for other similar purposes without substantial change.

Having thus explained the nature of the invention and described an operative manner of constructing and using the same, although without attempting to set forth all of the forms in which it may be made, or all of the forms of its use, what is claimed is:—

1. A motor of the character described comprising a casing having an intake chamber, a piston chamber, and an exhaust chamber, an approximately spherical rotor mounted in said casing, the surface of said rotor forming one wall of each of said chambers, a piston on said rotor, a rotatable abutment disk movable with said rotor but movable on an axis at an angle to the axis of rotation of the rotor, and means for introducing an impelling medium between the disk and the piston, said disk having an opening positioned to periodically coincide with the crossing line of travel of the piston.

2. A motor of the character described comprising a casing having an intake chamber, a

piston chamber, and an exhaust chamber, an approximately spherical rotor mounted in said casing, the surface of said rotor forming one wall of each of said chambers, an abutment disk rotatably mounted on said rotor and movable, on an axis at an angle to the axis of rotation of the rotor, a piston on the rotor, means independent of the piston providing a movable engagement between the disk and the rotor, and means for introducing an impelling medium between the disk and the piston.

3. A motor of the character described comprising a casing having an intake chamber, a piston chamber, and an exhaust chamber, a rotatable disk having its peripheral portion engaging said casing and having a central opening, an approximately spherical rotor also mounted within said casing and filling the opening in said disk, the surface of said rotor forming one wall of each of said chambers, means connecting the disk and the rotor so that rotation is imparted to said disk by said rotor, a piston on the rotor, said disk having an opening positioned to periodically coincide with the crossing travel of the piston, and means for introducing an impelling medium between the disk and the piston:

4. A motor of the character described comprising a casing, an abutment disk rotatably mounted in said casing and having a central opening provided with an inwardly extended radial projection, and a rotor also mounted in said casing and approximately fitting the opening in said disk, the axis of rotation of the disk being at an angle with respect to the axis of rotation of the rotor, said rotor having a recess complementary to said projection, a piston on the rotor, and means for introducing an impelling medium between the disk and the piston.

5. A motor of the character described comprising a casing, a circular disk having a central opening provided with an inwardly extending radial projection, an approximately spherical rotor fitting the opening in said disk, said rotor being mounted on an axis disposed at an angle to the axis of rotation of said disk, said rotor being provided with a curved recess in its surface into which said projection extends, an antifriction roll mounted on said projection, a piston on said rotor, and means for introducing an impelling medium between the piston and the disk.

6. A motor of the character described comprising a casing having an intake chamber, a piston chamber, and an exhaust chamber, a rotatable disk having its peripheral portion engaging said casing and having a central opening, an approximately spherical rotor fitting said opening but mounted on an axis disposed at an angle to the axis of rotation of said disk, the surface of said rotor forming one wall of each of said chambers, means con-

necting the disk and the rotor so that rotation is imparted to said disk by said rotor, a piston on the rotor, said disk having a cut away portion to permit passage of the piston therethrough, and means for periodically introducing an impelling medium between the disk and the piston on both sides of the disk.

7. A motor of the character described comprising a casing having an intake chamber, a piston chamber, and an exhaust chamber, a rotatable disk having its peripheral portion engaging said casing and having a central opening, an approximately spherical rotor filling said opening, and mounted on an axis disposed at an angle to the axis of rotation of said disk, the surface of said rotor forming one wall of each of said chambers, means connecting the disk and the rotor so that rotation is imparted to said disk by said rotor, a power piston on said rotor, a scavenger piston also on said rotor, said disk having cut-away portions positioned to periodically coincide with the crossing paths of the pistons, and means for introducing an impelling medium between the disk and the power piston on either side of the disk.

8. A motor of the character described comprising a casing having an intake chamber, a piston chamber, and an exhaust chamber, a rotatable disk having its peripheral portion engaging said casing and having a central opening, an approximately spherical rotor filling said opening and mounted on an axis disposed at an angle to the axis of rotation of said disk, the surface of said rotor forming one wall of each of said chambers, means connecting the disk and the rotor so that rotation is imparted to said disk by said rotor, a power piston on said rotor, a scavenger piston also on said rotor, said disk having cut-away portions positioned to permit passage of the pistons when their paths of movement cross that of the disk, means for introducing an impelling medium between the disk and the power piston on either side of the disk, the radial walls of the cutaway portions of the disk being provided with angular faces so disposed as to maintain the proper angular relation between the respective pistons and openings as the parts pass each other during their crossing lines of travel.

9. A motor of the character described comprising a casing, a rotatable disk having its peripheral portion engaging said casing and having a central opening and an inwardly projected radial finger, an approximately spherical rotor fitting said opening and provided with a recess into which said finger projects, so as to cause the two to rotate simultaneously, the axis of rotation of said rotor being at an angle to the axis of rotation of said disk, a power piston and a scavenging piston projecting from said rotor at diametrically opposite positions, said disk having radially disposed cut-away portions to provide clear-

ance for the respective pistons during their travel, and means for introducing an impelling medium between the outer piston and the disk on either side of the disk.

5 10. A motor of the character described comprising a casing having an intake chamber, a piston chamber, and an exhaust chamber, an angularly disposed abutment disk provided with a central opening, bearing  
10 means carried by said casing and rotatably supporting the periphery of said disk, an approximately spherical rotor filling the opening of said disk, the surface of said rotor forming one wall of each of said chambers,  
15 means connecting the disk and rotor to travel simultaneously, a piston on the rotor, and means introducing an impelling medium between the disk and the piston.

20 11. A motor of the character described comprising a casing having an intake chamber, a piston chamber, and an exhaust chamber, a shaft rotatably mounted in said casing, a spherical rotor carried by said shaft, said rotor forming one wall of each of said chambers,  
25 an abutment disk encircling said rotor and disposed at an angle to said shaft, a piston projecting from said rotor, means independent of the piston whereby the disk and the rotor are connected to travel simultaneously,  
30 and means for introducing an impelling medium between the disk and the piston.

35 12. A motor of the character described comprising a casing having an intake chamber, a piston chamber, and an exhaust chamber, a shaft rotatably mounted in said casing, a rotor connected to said shaft, said rotor forming one wall of each of said chambers, said rotor consisting of two approximately hemispherical complementary parts, means on  
40 the shaft holding said parts in assembled relation, a rotatably mounted abutment disk having an opening to receive said rotor, said disk being disposed at an angle to said shaft, means whereby the disk and rotor are caused  
45 to travel simultaneously, a piston on the rotor, and means for introducing an impelling medium between the disk and the piston.

50 13. A motor of the character described comprising a casing having an intake chamber, a piston chamber, and an exhaust chamber, an approximately hollow spherical rotor mounted in said casing, said rotor forming one wall of each of said chambers, a rotatable abutment disk movable with said rotor but at  
55 an angle to the axis of rotation of the rotor a piston on the rotor cooperating with said disk, means for introducing an impelling medium through the rotor into the space between the piston and the disk, and means for scavenging the motor through the rotor.  
60

65 14. A motor of the character described comprising a casing, an approximately spherical rotor mounted in said casing, a rotatable abutment disk encircling said rotor and moved thereby, but at an angle to the axis of

rotation thereof, a hollow piston projecting from the rotor and cooperating with said disk, said piston having a portion for storing compressed explosive mixture, means for supplying an impelling medium to the interior of the piston, and means whereby said  
70 impelling medium is periodically discharged from said hollow piston into the space between the piston and the disk.

75 15. A motor of the character described comprising a casing, an approximately spherical rotor mounted in said casing, a rotatable abutment disk encircling said rotor and moved thereby, but at an angle to the axis of  
80 rotation thereof, a hollow piston projecting from the rotor and cooperating with said disk, said piston having a portion for storing compressed explosive mixture and means for supplying said explosive mixture through the rotor into the space between the piston and  
85 the disk.

90 16. A motor of the character described comprising a casing, an approximately spherical rotor mounted in said casing, a rotatable abutment disk encircling said rotor and moved thereby but at an angle to the axis of  
95 rotation thereof, a hollow piston constructed to store compressed explosive mixture, said piston projecting from said rotor and provided with an outlet port normally closed by said casing, but periodically uncovered to introduce compressed explosive mixture between the piston and the disk, and means whereby the explosive mixture is supplied to  
100 the interior of said piston.

105 17. A motor of the character described comprising a casing, an approximately spherical rotor mounted in said casing, a rotatable abutment disk encircling said rotor and moved thereby but at an angle to the  
110 axis of rotation thereof, a hollow piston projecting from said rotor and provided with an outlet port normally closed by said casing, means whereby said outlet port is periodically opened and closed during the revolution of the rotor so as to control the introduction of an impelling medium between the piston and the disk, the front wall of said piston having a relief opening, and a spring pressed valve normally closing said  
115 relief opening.

120 18. A motor of the character described comprising a casing, an approximately spherical rotor, a rotatable abutment disk encircling said rotor and moved thereby, but at an angle to the axis of rotation thereof, a hollow piston projecting from the rotor and cooperating with said disk, said piston having a reserve chamber located within said  
125 rotor, so that compressed explosive mixture may be introduced into said reserve chamber through the piston, means whereby explosive mixture is introduced into said chamber, and means for periodically introducing  
130

charges of said explosive mixture into the casing between the piston and the disk.

19. A motor of the character described comprising a casing provided with an annular intake chamber, an approximately spherical rotor mounted in said casing and forming one wall of said intake chamber, a rotatable abutment disk encircling said rotor and moved thereby, but at an angle to the axis of rotation thereof, a hollow piston on said rotor, said piston having a reserve chamber located within the rotor, so that compressed explosive mixture may be introduced into said reserve chamber through the piston, means for introducing explosive mixture into the space ahead of said piston, means whereby said explosive mixture is stored within said piston, and means for periodically establishing communication between the interior of said piston and the interior of the casing, between the piston and the disk.

20. A motor of the character described comprising a casing, an approximately spherical rotor mounted therein, a rotatable disk encircling said rotor and moved thereby but at an angle to the axis of rotation thereof, means applying an impelling medium to impart movement to said rotor and said disk, a scavenging piston projecting from said rotor and provided with an outlet channel in its forward face, and means for placing said channel in communication with the atmosphere.

21. A motor of the character described comprising a casing, an approximately spherical rotor mounted therein, a rotatable abutment disk encircling said rotor and moved thereby but at an angle to the axis of rotation thereof, means for impelling the rotor and the disk, a scavenging piston having an outlet channel in its forward face, and an exhaust conduit located within the rotor and communicating with said channel.

22. A motor of the character described comprising a casing provided with an exhaust chamber, an approximately spherical rotor mounted in said casing, a rotatable abutment disk encircling said rotor and moved thereby at an angle to the axis of rotation thereof, means for imparting movement to the rotor and the disk, a scavenging piston having an outlet channel, and means for maintaining communication between said channel and said exhaust chamber.

23. A motor of the character described comprising a casing, having an intake chamber and an exhaust chamber normally closed by the surface of said rotor, an approximately spherical rotor mounted in said casing and normally closing said chambers, a rotatably mounted disk encircling said rotor and moved thereby at an angle to the axis of rotation therewith, a hollow power piston projecting from the rotor, means for introducing an impelling medium into the cas-

ing, said piston having means for storing said impelling force, means for periodically discharging said impelling medium from said piston between it and the disk, a scavenging piston projecting from said rotor and provided with an outlet conduit, and means for establishing communication between said conduit and said exhaust chamber.

24. A motor of the character described comprising a casing provided with a piston chamber, an approximately spherical rotor mounted therein and provided with an outlet port, a rotatable disk encircling said rotor and moved thereby but at an angle to the axis of rotation thereof, an impelling piston, a scavenging piston contiguous to said outlet port, and means for introducing an impelling medium into said piston chamber through said inlet port.

25. A motor of the character described comprising a plurality of firing chambers, an approximately spherical rotor mounted in said casing, a rotatable abutment disk encircling said rotor and movable therewith, but at an angle to the axis of rotation thereof, a hollow piston projecting from said rotor, means for periodically introducing charges of explosive mixture through said piston into the respective firing chambers, and means for firing the charges.

26. A motor of the character described comprising a casing provided with a plurality of firing chambers, an approximately spherical rotor mounted in said casing, a rotatable abutment disk encircling said rotor and moved thereby, but at an angle to the axis of rotation thereof, a hollow piston projecting from said rotor, said piston having an opening normally closed by the casing, but uncovered when it comes opposite the respective firing chambers during revolution of the rotor, whereby charges of explosive mixture are introduced into said firing chambers, and means in the firing chambers for firing the charges.

27. A motor of the character described comprising a casing provided with a plurality of firing chambers, an approximately spherical rotor mounted in said casing, a rotatable abutment disk encircling said rotor and moved thereby, but at an angle to the axis of rotation thereof, a hollow piston projecting from said rotor, said piston having an opening normally closed by the wall of the casing, but uncovered when it comes opposite the respective firing chambers, whereby charges of explosive mixture are introduced into said firing chambers, means in the explosion chambers for firing the charges, said firing chambers having walls shaped to direct the full force of the explosion against the piston in an approximately straight line.

28. A motor of the character described comprising a casing provided with a plurality of firing chambers, an approximately spher-

- ical rotor mounted in said casing, a rotatable abutment disk encircling said rotor and moved thereby, but at an angle to the axis of rotation thereof, a hollow piston projecting from said rotor, said piston having an opening normally closed by the wall of the casing, but uncovered when it comes opposite the respective firing chambers, whereby charges of explosive mixture are introduced into said firing chambers, and means in the firing chambers for firing the charges. 70
29. A motor of the character described comprising a casing having a plurality of firing chambers, an approximately spherical rotor mounted in said casing, a rotatable abutment disk encircling said rotor and moved thereby, but at an angle to the axis of rotation thereof, a hollow piston projecting from said rotor and having a reserve chamber located within the rotor, means for introducing an explosive mixture into the reserve chamber through said piston, means whereby explosive charges are delivered by said piston into the respective firing chambers, and means for firing said charges. 75
30. A motor of the character described comprising a casing having a plurality of firing chambers and an intake chamber, an approximately spherical rotor mounted in said casing and forming one wall of the intake chamber, a rotatable abutment disk encircling said rotor and moved thereby, but at an angle thereto, a hollow piston projecting from said rotor and provided with a reserve chamber constructed to periodically deliver charges of explosive mixture into the respective firing chambers during revolution of the rotor, and means for firing said charges. 80
31. A motor of the character described comprising a casing provided with independent intake and exhaust chambers, an approximately spherical rotor normally closing the said intake and exhaust chambers, a rotatable abutment disk encircling said rotor and moved thereby but at an angle to the axis of rotation thereof, a hollow piston communicating with said intake chamber, a scavenging piston communicating with said exhaust chamber, means whereby the explosive mixture is first compressed and then introduced through the hollow piston into the firing chambers, and means for exploding said charges. 85
32. A rotor of the character described comprising a casing provided with an explosion chamber, an intake chamber, an exhaust chamber, an approximately spherical rotor mounted in said casing and serving as a wall for each of said chambers, a rotatable abutment disk encircling said rotor and moved thereby but at an angle to the axis of rotation thereof, whereby the explosion chamber is divided into two parts, pistons on said rotor projecting into the explosion chamber, said pistons cooperating with said abutment disk to divide the explosion chamber into supplemental chambers, and means for introducing an impelling medium between the piston and said disk. 90
- In testimony whereof I have hereunto set my hand.
- WILLIAM E. SIMMONS. 95
- 100
- 105
- 110
- 115
- 120
- 125