

(No Model.)

T. W. EVERSOLE.
SELF HEATING SOLDERING IRON.

No. 525,494.

Patented Sept. 4, 1894.

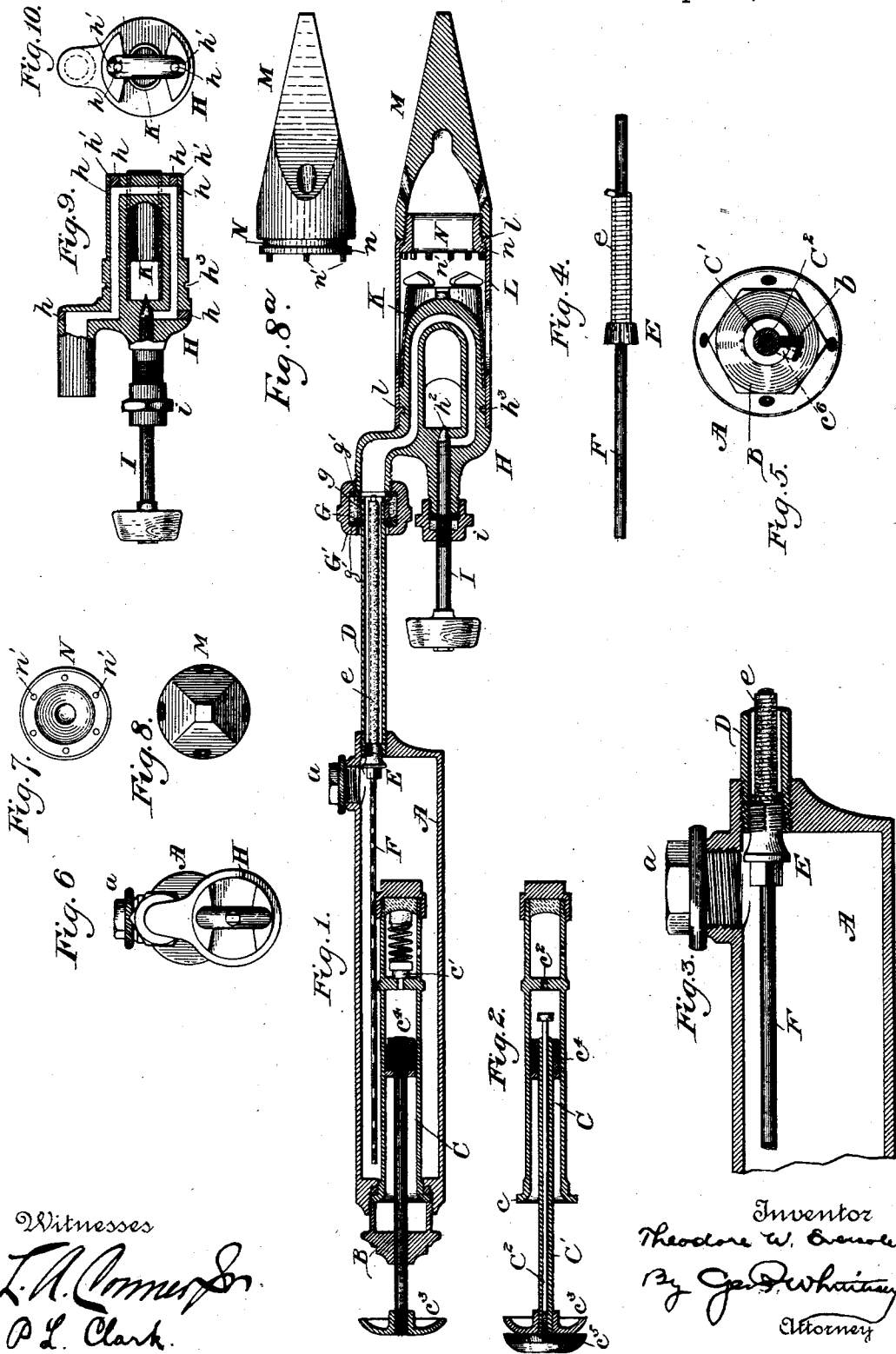

Witnesses
L. A. Combs
P. L. Clark

Inventor
Theodore W. Eversole
By *Geo. Whitney*
Attorney

UNITED STATES PATENT OFFICE.

THEODORE W. EVERSOLE, OF WASHINGTON, DISTRICT OF COLUMBIA.

SELF-HEATING SOLDERING-IRON.

SPECIFICATION forming part of Letters Patent No. 525,494, dated September 4, 1894.

Application filed May 29, 1893. Serial No. 475,919. (No model.)

To all whom it may concern:

Be it known that I, THEODORE W. EVERSOLE, a citizen of the United States, residing at Washington, in the District of Columbia, have invented certain new and useful Improvements in Self-Heating Soldering-Irons; and I do declare the following to be a full, clear, and exact description of the invention, such as will enable others skilled in the art to which it appertains to make and use the same, reference being had to the accompanying drawings, and to the letters of reference marked thereon, which form a part of this specification.

My invention relates to soldering irons, and it is an improvement upon the self-heating iron heretofore patented by me, No. 388,187, dated August 21, 1888.

The present invention consists in certain details of construction which will be duly set forth hereinafter.

The object of the improvement is to render the iron more serviceable and efficient, certain practical objections incident to prior constructions having been at length overcome, as hereinafter set forth.

In the drawings, Figure 1 is a longitudinal section of my improved soldering iron. Fig. 2 shows a modification of the pump. Fig. 3 is a view on an enlarged scale of the regulating valve. Fig. 4 shows a modified valve. Fig. 5 is an end view of the reservoir with the pump rod in section. Fig. 6 is an end view of the iron, with the holder removed. Fig. 7 is an end view of the swivel nut, and Fig. 8 is an end view of the tip. Fig. 8^a is a side view of the same. Figs. 9 and 10 are sectional and end views respectively of a modified construction of the burner.

The general construction of the iron is the same as in the one shown and described in my patent above referred to.

The handle A is hollow to constitute a reservoir for the gasoline or other liquid fuel. Its rear end is closed by a screw plug B, which clamps the flange c at the rear end of the air pump barrel C, housed within the handle A. The flange is suitably packed to make a tight joint. A check valve c' closes the port c² in the inner end of the pump barrel. It is found that the gasoline corrodes this valve (which is usually made of soft rubber), thereby per-

mitting the air to escape and thus weakening the pressure in the reservoir. To overcome this, I prefer to make the pump rod C' tubular as shown in Fig. 2, and provide a central opening through the handle c³ and piston c⁴, so that I am enabled to insert a stem C² having its inner end headed or otherwise suitably formed to close the port c². The stem C² is externally threaded to mesh with an internal thread in the tube C', and its outer end has a handle c⁵ preferably similar in shape to the handle c³. The pump rod C' has a projecting pin c⁶ which is adapted to enter an L-shaped slot b in the neck of the screw plug B. A slight turn of the pump rod C' locks the pin in the slot, and securely holds the pump rod while the valve stem C² is screwed in to close the port c². By this means, the air pressure produced by the pump can be held in the reservoir. In the forward end of the reservoir A is an opening into which is screwed or otherwise tightly secured a pipe D leading to the burner. Fitting the end of this pipe is a plug E, which governs the flow of gasoline into the pipe. This plug may be a screw, flattened on one or more sides, or it may be a round plug with one or more grooves running lengthwise as shown in Fig. 4. The filling orifice of the reservoir is located close to this plug, so that said plug can be adjusted when the stopper a is removed from said orifice.

Through the plug E runs a small tube F, which extends from near the rear end of the reservoir to or near to the outer end of the pipe D. The portion of the tube inside of the pipe is preferably wrapped with asbestos e. When the iron is held with the point downward, this tube serves to conduct the air from the upper end of the reservoir to the delivery end of the pipe D. When the iron is inclined upward, the gasoline feeds through the tube by reason of the air pressure, the air passing into the pipe around the plug E. The tube F thus enables the iron to work equally well in any position. The outer end of the pipe D screws into a bushing g in a collar G of vulcanized fiber, asbestos, or the like, which is clamped to the burner H by means of the union G'. A washer g' of similar material is placed at each end of the collar, the whole forming a non-conducting connection be-

tween the handle and the burner, and preventing the handle from becoming uncomfortably or dangerously hot.

The burner is like that shown in my former patent, comprising a cylindrical base carrying an arched pipe, one end of which communicates with the tube D and the other with a minute jet orifice h^2 at the center of the base, controlled by a needle valve. The arch of the pipe lies in front of this orifice and transverse to the flame issuing therefrom, so that the liquid fuel passing through this portion of the pipe becomes vaporized by the heat of the flame.

Some trouble has been experienced with the burner valve by reason of the heating and consequent expansion of its valve stem I, which causes its screw threaded portion to bind in its nut and renders it hard to turn. I obviate this trouble by forming the body of the valve stem smooth, and threading it at its outer portion only, forming the co-operating nut in the gland z . In case the stem should stick, a drop of oil can be applied to the threads. In the old construction the threaded parts were inclosed and inaccessible for oiling.

In making the burner H it requires considerable care in molding and casting to core out the passages. In lieu of coring, the burner may be cast solid, and the passages drilled out, as shown in Fig. 9, the outer ends of the drill holes being then plugged as at h . In this construction, it is preferable to form squared shoulders h' on the outer end of the burner, to give better opportunity for starting the drill. When this construction is adopted, the hood K is preferably placed between the legs of the arched portion of the burner. The hood may however, surround the arch as shown in Fig. 1, being simply a frusto-conical shell to confine the flame issuing from the jet orifice h^2 .

The holder L is attached to the burner by a bayonet joint or mutilated screw-thread, a slightly inclined groove h^3 being formed on each side of the base of the arched portion of the burner to receive lugs l on the inside of the end of the holder. The sides of the holder contain suitable openings for the escape of gases, and for giving draft. Secured to the outer end of the holder is the tip M, which may be of the usual pyramidal shape, as in Fig. 1, or of any desired configuration. The tip may be fastened directly to the holder but I prefer to use a swiveling attachment, to enable the tip to be angularly adjusted since it is desirable to hold the iron with the filling orifice always uppermost. The swiveling attachment which I prefer is the ring or collar N having a flange n to seat against the internal flange n' on the holder and provided with a threaded portion projecting out beyond the end of the holder to enter a tapped socket in the tip M. The collar has a number of pins n' or the like, to enable it to be held stationary by means of a lever thrust through one

of the openings in the holder, while the tip is being screwed on. By loosening the tip it is free to be turned to any desired angle, where the collar can be tightened to hold it. This construction also provides for readily and quickly changing the tip when desired.

While I have described my soldering tool as provided with a tip M and holder L, yet I do not limit myself to such construction, but wish it to be understood that I may omit the tip and holder and use the burner with a tapering hood upon it, such as the hood K. In this form it is available for many uses which will readily suggest themselves to those skilled in the art.

Having thus described my invention, what I claim is—

1. In a self heating soldering iron, the combination with a reservoir of liquid fuel, of an air pump barrel, having a delivery port in its end, communicating with said reservoir, a hollow pump rod, and a stop valve having its stem passing through said pump rod, substantially as described.

2. In a self-heating soldering iron, the combination with a reservoir for liquid fuel, of an air pump barrel, having a delivery port in its end communicating with said reservoir, a hollow pump rod, having internal screw threads, and a stop valve having a threaded stem passing through said pump rod, substantially as described.

3. In a self-heating soldering iron, the combination with a reservoir for liquid fuel, of an air pump barrel, having a delivery port communicating with said reservoir, and provided with a check valve, and a stop valve for closing said port independently of the check valve, substantially as described.

4. In a self-heating soldering iron, the combination with an air pump barrel located inside the handle of the iron, having a delivery port provided with a check valve, of a stop valve for independently closing said port, and means for operating said valve from outside the handle of the iron, substantially as described.

5. In a self-heating soldering iron the combination with an air pump barrel, having a delivery port, of a hollow pump rod, a stop valve having its stem passing through the pump rod, and means for locking the pump rod when the piston is at the end of the delivery stroke, substantially as described.

6. In a self-heating soldering iron, the combination with the air pump having a screw plug B containing an L-shaped slot b , of a hollow internally threaded pump rod having a pin c^6 to engage with said slot, and a threaded stem passing through said rod and having a stop valve on its inner end, substantially as described.

7. In a self-heating soldering iron, the combination with a tubular reservoir for liquid fuel and a pipe leading from one end thereof, of a small air tube extending from near the other end of said reservoir to near the de-

livery end of the pipe, substantially as described.

8. In a self-heating soldering iron, the combination with a tubular reservoir for liquid fuel and a pipe leading from one end thereof, of a small air tube extending from near the other end of said reservoir to near the delivery end of the pipe, and having that portion within the pipe wrapped with a heat resisting fibrous substance, substantially as described.

9. In a self-heating soldering iron, the combination with a tubular reservoir for liquid fuel and a pipe leading from one end thereof, of a small air tube extending from near the other end of said reservoir to near the delivery end of the pipe, and a valve surrounding said tube when it enters the pipe, substantially as described.

10. In a self-heating soldering iron, the combination with a tubular reservoir for liquid fuel, and a pipe leading from one end thereof, of a small air tube extending from near the other end of said reservoir to near the delivery end of the pipe, and a valve having a passage way along one side and surrounding the tube where it enters the pipe, substantially as described.

11. In a self-heating soldering iron, the combination with a tubular reservoir for liquid fuel having a large filling orifice near one

end, of a delivery pipe leading from that end of the reservoir close to the filling orifice, and an adjustable valve controlling that end of the pipe and accessible through said orifice, substantially as described.

12. In a self-heating soldering iron, the combination with a tubular reservoir for liquid fuel and a pipe leading from one end thereof, of an air tube located inside of said reservoir and pipe, and extending from near one end of the reservoir to near the delivery end of the pipe, substantially as described.

13. In a self-heating soldering iron, the combination with the pipe D, of the collar G of non-conducting material having a metallic bushing *g* screwed upon the pipe D, the burner H, the union G', and the non-conducting washers *g'* at each end of the collar, substantially as described.

14. In a soldering iron, the combination with the holder L having openings in its sides, of the swiveling ring N having pins *n'*, and a tip screwed upon the projecting portion of said ring, substantially as described.

In testimony whereof I affix my signature in presence of two witnesses.

T. W. EVERSOLE.

Witnesses:

D. H. MATHEWS,
W. E. WILLIAMSON.