

W. E. NICKERSON.
ELECTRICALLY CONTROLLED ELEVATOR.

No. 403,441.

Patented May 14, 1889.

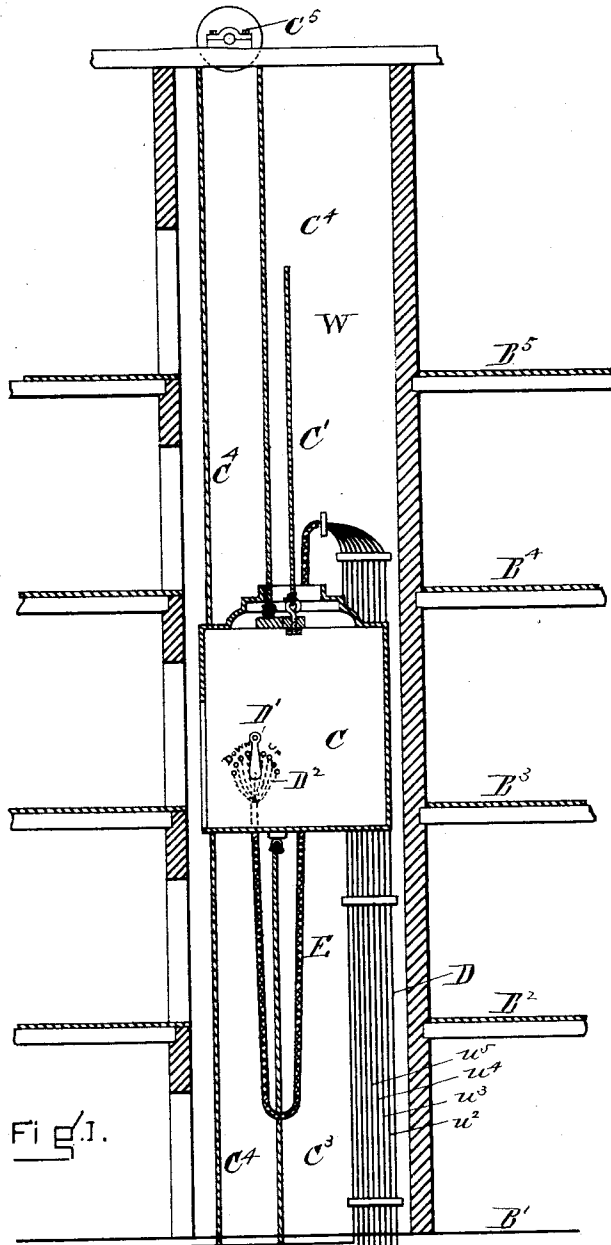

WITNESSES.

Franklin Parker
Matthew M. Blunt

INVENTOR.

William E. Nickerson

W. E. NICKERSON.
ELECTRICALLY CONTROLLED ELEVATOR.

No. 403,441.

Patented May 14, 1889.

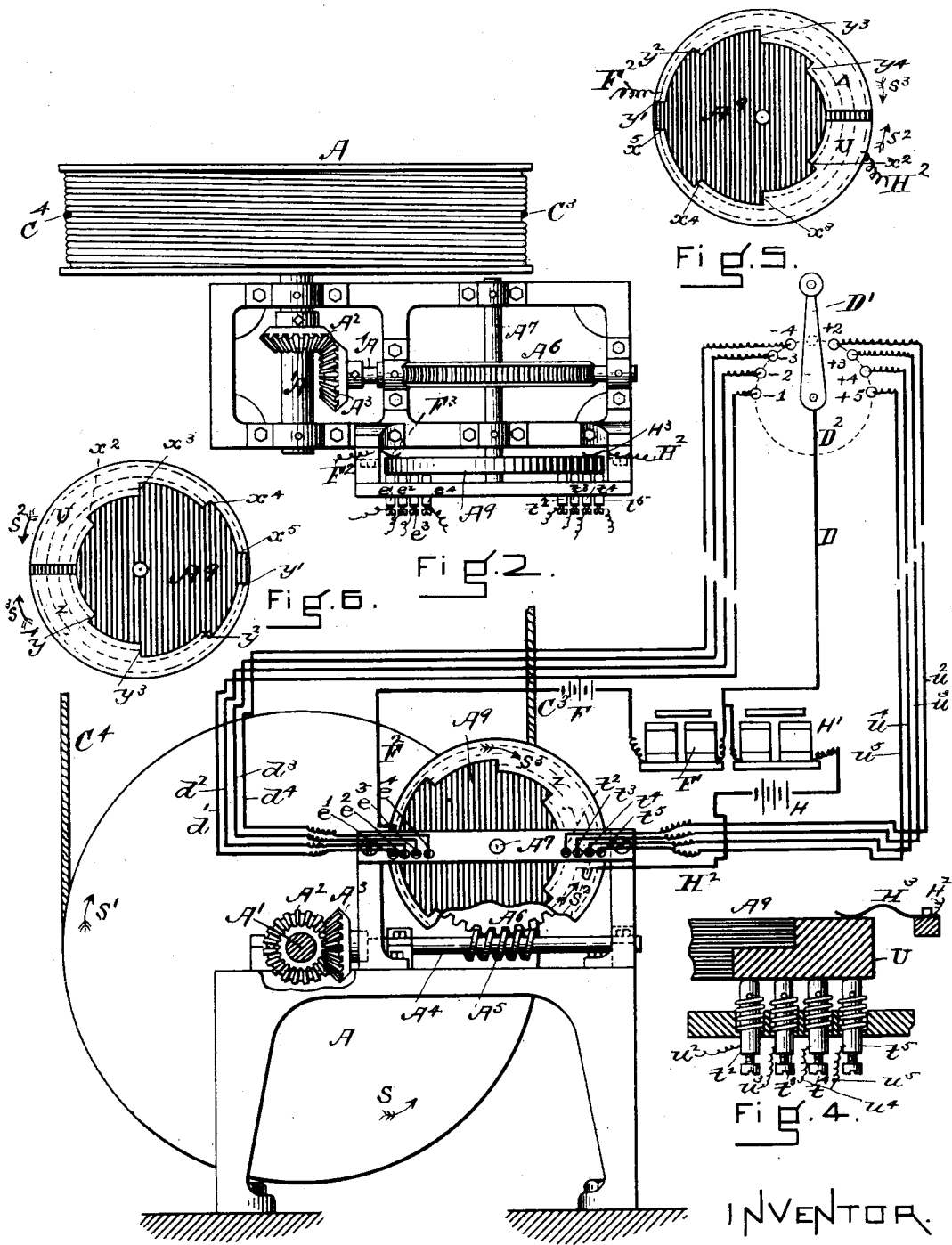

WITNESSES.
Frank H. Parker
Matthew W. Blunt,

INVENTOR.
William E. Nickerson

UNITED STATES PATENT OFFICE.

WILLIAM E. NICKERSON, OF CAMBRIDGE, MASSACHUSETTS.

ELECTRICALLY-CONTROLLED ELEVATOR.

SPECIFICATION forming part of Letters Patent No. 403,441, dated May 14, 1889.

Application filed March 8, 1889. Serial No. 302,454. (No model.)

To all whom it may concern:

Be it known that I, WILLIAM EMERY NICKERSON, of Cambridge, in the county of Middlesex and State of Massachusetts, have invented certain new and useful Improvements in Electrically-Controlled Elevators, of which the following, taken in connection with the accompanying drawings, is a specification.

The device in which my invention is embodied consists of a mechanism located in any convenient position in relation to the elevator-well, by which contact-plates—one to be used when the elevator-carriage is ascending and the other to be used when the elevator-carriage is descending—are caused to be moved by and in unison with the movement of the elevator-carriage, and in arranging in connection with said contact-plates friction contact-points each adapted and located to rest upon its own determined path, so that as the contact-plates move each point will, at a certain fixed place, be left to rest upon insulation, and thus break the circuit to which it belongs, and also in arranging in connection with the contact-points circuits for connecting them with motors for controlling the carriage-operating mechanism, and with a switch device within the elevator-carriage, by means of which the attendant may by means of an index-electrode control the movement of the carriage.

In describing this device I use the following illustrations, in which—

Figure 1 is a view showing the relative positions and general arrangement of the different leading features of my device as applied to an ordinary passenger-elevator. Fig. 2 is a plan showing the mechanism that I use for transmitting the motion of the elevator-carriage to the contact-plates. Fig. 3 is an elevation showing parts of the transmitting device and the contact-plates, together with the motors, the circuits, and switch device. Figs. 4, 5, and 6 are diagrammatic views for illustrating the operation of my invention.

Referring to Fig. 1, W represents the elevator-well room; B¹ B² B³ B⁴ B⁵, the floors; C, the carriage, and C' the hoisting-rope.

D' represents that part of the switch device which I call the "index-electrode."

E is a cord or cable containing the wires that constitute the various circuits.

The electric device for effecting the upward controlling mechanism of the hoisting apparatus is designated by H H', and that for effecting the downward controlling mechanism is designated by F F'.

The position of the index mechanism is indicated by the drum A, Fig. 1. This drum A is connected by the ropes C³ and C⁴ to the elevator-carriage C. The rope C³ passes directly from the drum A to the lower part of the carriage C, and the rope C⁴ passes up over the sheave C⁵ and then down to the top of the elevator-carriage, as shown in Fig. 1. As the ropes C³ and C⁴ pass around the transmitting-drum A and thence to the carriage, it is evident that any motion of the carriage will be communicated to the drum A—that is, when the carriage ascends the drum will move in the direction of the arrow S, Fig. 3, and when the carriage descends the drum will move in the direction of the arrow S', Fig. 3.

The motion of the drum A, Figs. 2 and 3, is transmitted to the contact-plate block A⁹ by the following mechanism: The drum A has a shaft, A¹, which has upon it a beveled gear, A², the motion of which is imparted to the gear A³, and by it through the shaft A⁴ and worm A⁵ to the gear A⁶, and thence through the shaft A⁷ to the contact-plate block A⁹.

The mechanism by which the motion of the elevator-carriage is transmitted to the contact-plate block A⁹ is so made that at each full passage of the carriage from bottom to top, or vice versa, the contact-plate block makes a half-rotation. As the carriage goes up, the rotation of the block A⁹ is in the direction of the arrow S², and as the carriage goes down, in the direction of the arrow S³.

The contact-plates on the contact-plate block are designated by U and Z, U being the contact-plate in use when the carriage is going up, and Z being the contact-plate in use when the elevator-carriage goes down.

The switch device (indicated by D², Fig. 3) consists of a series of contact-posts, +2 +3 +4 +5, for the ascension of the elevator-carriage, and a series, -4 -3 -2 -1, for the descent of the carriage.

D' is an electrode-index, and serves to connect the various circuits, and is intended to be operated by the attendant. Each of the contact-posts +2 +3 +4 +5 is connected by

a wire to corresponding spring contact-points $t^2 t^3 t^4 t^5$, their respective wires being designated by $u^2 u^3 u^4 u^5$. Each of the contact-posts $-4 -3 -2 -1$ is connected by a wire to corresponding spring contact-points, $e^4 e^3 e^2 e^1$, their respective wires being designated by $d^4 d^3 d^2 d^1$. The contact-plate block A^9 as used in this form of my invention is a rotating disk; but it can be made as a sliding block of any desired form.

The contact-plate block A^9 , as shown, has two contact-plates, U and Z, each of which is made in the form of a snail-cam, each having four offset points or terminals—that is, the plate U has terminals at $x^5 x^4 x^3 x^2$, (see Figs. 5 and 6,) and the plate Z has terminals at $y^7 y^6 y^5 y^4$.

The numerals used in connection with the letters are intended to assist the reader in connecting the various circuits and their parts with the contact-posts of the switch device and with the floors to which the carriage may be directed.

The dotted lines in Figs. 5 and 6 indicate paths that the contact-points $t^2 t^3 t^4 t^5$ and $e^7 e^6 e^5 e^4$ trace on the contact-plates, and serve to indicate at which terminal point of the contact-plate each particular contact-point will break its circuit. For convenience in speaking of the paths I will consider them to be designated by the same letter that its respective terminal is designated by—that is, the path that ends at the terminal offset x^2 will be referred to as path x^2 .

The operation of my device is as follows: The elevator-carriage being at the first floor and at rest, the index-electrode D' will be standing vertically, as shown in Fig. 3. Now, if the attendant wishes to start the elevator, he turns the index-electrode D' to the right, so as to make a contact with one of the posts $+2, +3, +4$, or $+5$ —that is, if he wishes to go to the second floor he stops the index-electrode on the post $+2$, Fig. 3. Then the circuit will be made through the wire u^2 , spring-point t^2 , contact-plate U, spring-plate H^3 , and wire H^2 , electric device $H' H$, and back through the wire D and index-electrode D' , thus completing the circuit and starting the electric device, and through it effect the controlling mechanism for causing the carriage to ascend, and the carriage will continue its upward motion until the spring contact-point t^2 in the path x^2 passes off of the contact-plate U at x^2 onto insulation. Then, the circuit being broken, the carriage stops. If the attendant had placed the index-electrode D'

onto the post $+5$, then the circuit would have been through u^5 and pin t^5 , and the pin t^5 in its path x^5 would pass off of the contact-plate U at x^5 —that is, when the carriage had arrived at the fifth floor. If we start with the elevator-carriage at the top, in which case the contact-plate block A^9 will be in the position shown in Fig. 6—that is, the down contact-plate Z will occupy the position shown in Fig. 6—then the attendant will turn the index-electrode D' to the left onto some one of the posts—say -4 . This will make a circuit through d^4 and spring-point e^4 to the contact-plate Z, (now in the position indicated in Fig. 6,) spring-plate F^3 , wire F^2 , to electric device $F' F$, and through D to index-electrode D' , thus completing the circuit and starting the electric device $F' F$ and effect the downward movement of the carriage. This downward movement will continue until the spring contact-point e^4 , passing along the path y^4 , leaves the contact-plate Z at y^4 and breaks the circuit. It is to be remembered that in the downward movement of the elevator the contact-plate block A^9 turns in the direction of the arrow S^3 .

I claim—

1. In an electrically-controlled elevator, the combination of a contact-plate block arranged to move in unison with the movement of the elevator-carriage and having contact-plates each connected to one pole of an electric device, and having resting upon it electric contact-points, each of which is connected electrically to switch-posts in the elevator-carriage, as described, with an index-electrode electrically connected with both electric devices and adapted to be set by the attendant, all substantially as and for the purpose set forth.

2. In an electrically-controlled elevator, the combination of the carriage C, ropes $C^3 C^4$, index-drum A, transmitting mechanism, and contact-plate block A^9 , having contact-plates Z and U, with the contact spring-points $t^2 t^3 t^4 t^5$ and $e^7 e^6 e^5 e^4$ and contact-posts $+2 +3 +4 +5$ and $-1 -2 -3 -4$, index-electrode D' , the electrical circuits, and devices, substantially as and for the purpose set forth.

In testimony whereof I have signed my name to this specification, in the presence of two subscribing witnesses, on this 7th day of March, A. D. 1889.

WILLIAM E. NICKERSON.

Witnesses:

FRANK G. PARKER,
MATHEW M. BLUNT.