

(No Model.)

W. K. CRAWFORD.  
UNIVERSAL NOZZLE.

No. 525,487.

Patented Sept. 4, 1894.

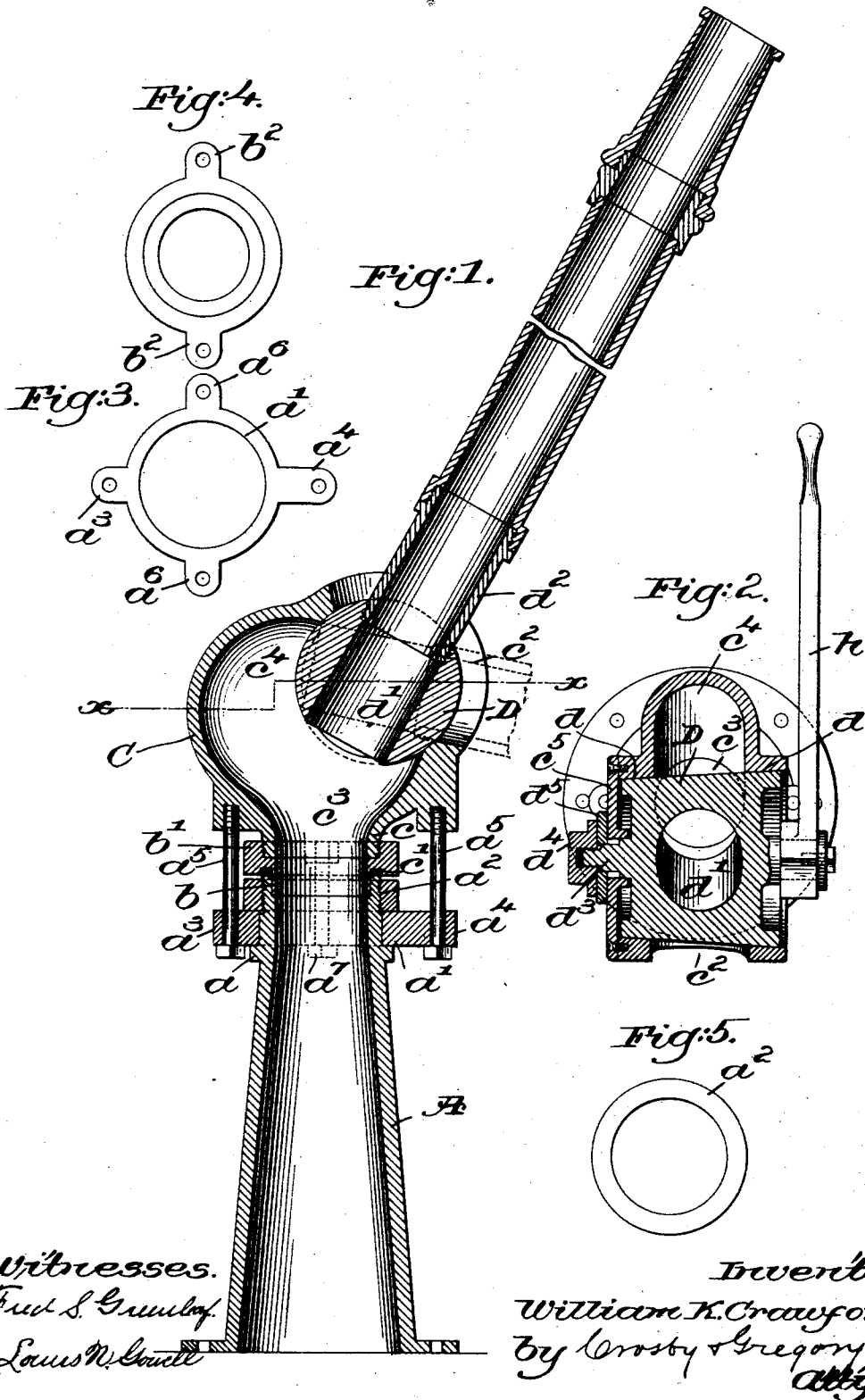

Witnesses.  
Fred S. Gumbel  
Louis M. Small

Inventor  
William K. Crawford,  
by Crosby & Gregory  
Attys.

# UNITED STATES PATENT OFFICE.

WILLIAM K. CRAWFORD, OF BOSTON, MASSACHUSETTS, ASSIGNOR TO  
ANDREW J. MORSE & SON, OF SAME PLACE.

## UNIVERSAL NOZZLE.

SPECIFICATION forming part of Letters Patent No. 525,487, dated September 4, 1894.

Application filed June 30, 1893. Serial No. 479,235. (No model.)

*To all whom it may concern:*

Be it known that I, WILLIAM K. CRAWFORD, of Boston, county of Suffolk, State of Massachusetts, have invented an Improvement in Universal Nozzles, of which the following description, in connection with the accompanying drawings, is a specification, like letters on the drawings representing like parts.

This invention relates to universal nozzles of the class shown and described in United States Patent No. 245,007, dated August 2, 1881.

The device shown in the patent referred to consists essentially of a revoluble shell provided with a conical seat which receives a rotatable plug carrying the nozzle. The outlet opening in the plug which leads to the nozzle is made flaring or tunnel-like to permit the plug with the nozzle to be rotated through a certain arc to direct the stream in different directions, and still preserve communication between the inlet and the nozzle through the outlet opening in the plug. In the device shown in the patent referred to, however, the plug fits its conical seat tightly throughout its length at that side at which the water inlet is located, the result being that the nozzle cannot be directed below a horizontal position without partially closing the inlet, and the lower the nozzle is directed, the more will the inlet be closed by the plug. The inlet cannot be made more flaring for practical reasons, the result being that the range of the device is unduly limited.

This invention has for its object to improve devices of the class shown in the patent referred to, whereby the range of the device may be very greatly enlarged, and its utility correspondingly increased.

In accordance with this invention a stand-pipe is provided near its outlet end with a circumferential seat or lip, upon which is supported a revoluble ring, which, in turn, is held against displacement by a nut. A shell is connected with a collar which is fitted in the upper end of the stand-pipe, and the whole bolted together. A rotatable plug is arranged in the outlet of the shell and a delivery nozzle is provided, and adjacent to said plug the shell is constructed with a clearance chamber extended laterally from said inlet around the

periphery of the plug and in the plane of the outlet and in extent sufficient to permit free admission of the water to the plug and nozzle in any position of the nozzle beyond the vertical in one direction and below the horizontal in the other direction.

This invention also comprehends certain details of construction to be hereinafter described and pointed out in the claims.

Figure 1 of the drawings, represents in vertical section one form of universal nozzle embodying this invention; Fig. 2, a section taken on the irregular section line  $x-x$  Fig. 1; Figs. 3, 4 and 5, details to be referred to.

Referring to the drawings, A represents a suitable stand-pipe of desired size, the same in the present construction being provided at a short distance from its upper end with a circumferential seat or lip  $a$  upon which rests the revoluble ring  $a'$  retained in its position upon the said circumferential lip by a ring-nut  $a^2$  threaded upon the upper end of the stand-pipe.

The upper end of the stand-pipe is counter-bored for a short distance to receive the gland  $b$  depending from the collar  $b'$ , said collar at its upper end receiving the shell C of the device, said shell in the present instance having its neck  $c$  tapped into the said collar as shown in Fig. 1.

A packing  $c'$  is introduced between the collar  $b'$  and the end of the stand-pipe A to render the joint between the two perfectly tight, yet permitting one to be revolved upon and with relation to the other.

The ring  $a'$ , see Fig. 3, is provided with two diametrically opposite ears  $a^3$ ,  $a^4$ , through which respectively are passed bolts  $a^5$ , tapped into suitable bosses upon the shell C, and by means of which the said shell may be drawn down to compress the packing  $c'$  and render tight the joint between the revoluble collar  $b'$  and the stand-pipe. The said ring  $a'$  is also provided with two diametrically opposite ears  $a^6$  located intermediate of the ears  $a^3$ ,  $a^4$ , and through which respectively are passed bolts  $a^7$ , one of which is shown in dotted lines Fig. 1, which bolts are tapped into ears  $b^2$  formed on the collar  $b'$ , see Fig. 4, the said bolts  $a^7$  furnishing additional means by which to draw the parts tightly together.

A rotatable plug or valve D is mounted in the shell C, the bearings  $d$  for the said plug being located at or near the ends of the latter, as best shown in Fig. 2.

5 The plug D is provided with a centrally located outlet opening or passage  $d'$  into which at one end, as shown, is tapped the butt end of the nozzle  $d^2$  of usual or desired shape or construction, the said nozzle protruding  
10 through a slot-like opening  $c^2$  in the shell C, see Fig. 1.

In accordance with the principal part of this invention the inlet  $c^3$  for the shell C is provided with a laterally extended clearance  
15 space or passage  $c^4$  which extends to one side of or laterally from the said inlet around the periphery of the plug D between its end bearings and in the plane of the outlet in order to permit the said plug to be rotated through  
20 more than ninety degrees, and yet always provide a free communication between the opening  $d'$  therein and the inlet  $c^3$  of the shell. For example, the plug may be turned into a vertical position and have an almost straight  
25 communication between the nozzle and the inlet  $c^3$ , and from this vertical position it may be turned down toward or into a position at least ten degrees below horizontal, as shown by dotted lines, communication still being had be-  
30 tween the nozzle and the said inlet opening by means of or through the clearance space  $c^4$ . Were this clearance space omitted and the inlet  $c^3$  carried directly to the bore or seat in the shell, it would be impossible to rotate the  
35 plug  $d$  for any distance, without carrying the opening in the plug past the entrance to the inlet  $c^3$ , and thereby cutting off the inlet as the conical plug in a usual valve operation to cut off communication to the pipe in which  
40 it is placed.

As previously referred to, there is a limit to the enlargement of the opening in the plug owing to the size of the plug, but by making the opening in the plug of its usual normal  
45 size and providing a clearance extending laterally from the entrance inlet around the outside of the plug, the latter may be turned to a considerable distance past the actual entrance to the inlet, and yet provide a free and  
50 full communication from the said inlet to the said opening through the clearance. This

clearance may be extended to one or both sides according to the particular range it is desired to give to the nozzle  $d^2$ .

In practice the plug will be provided with 55 suitable means, as for example the handle  $h$ , by which it may be rotated to change the direction in which the nozzle points, and the entire shell carrying the nozzle with it may be rotated freely about and upon the stand-  
60 pipe A. The plug is drawn into its seat in the shell by suitable means or devices, I having herein shown a plate  $c^5$  applied to the shell through which is extended a central lug  $d^3$  on one end of the plug, the said lug being  
65 threaded to receive a nut  $d^4$  between which and the said plate  $c^5$  is interposed a suitable washer as  $d^5$ . By this means the plug may be drawn tightly to its seat to prevent leakage, yet the plug may be readily removed. 70

I claim—

1. In a nozzle, a stand-pipe A provided with a circumferential seat or lip  $a$ , the rotatable ring  $a'$ , and nut  $a^2$  therefor, the collar  $b'$  and shell carried thereby, the bolts  $a^5$  and  $a^7$ , the  
75 rotatable plug and the nozzle carried thereby, all constructed and to operate substantially as described.

2. The combination of a stand-pipe provided with a circumferential seat or lip  $a$ , the rotatable ring  $a'$ , nut  $a^2$ , collar  $b'$ , shell C mounted in said collar and having an inlet and an outlet, bolts  $a^5$  and  $a^7$  for connecting these parts, and a rotatable plug arranged in the outlet of said shell and provided with a nozzle, the  
85 said shell having a clearance chamber  $c^4$  extending laterally from said inlet around the periphery of the plug and in the plane of the outlet, and in extent sufficient to permit free admission of the water to the plug and nozzle  
90 in any position of the nozzle beyond the vertical in one direction and below the horizontal in the other direction, substantially as described.

In testimony whereof I have signed my  
95 name to this specification in the presence of two subscribing witnesses.

WILLIAM K. CRAWFORD.

Witnesses:

FREDERICK L. EMERY,  
E. J. BENNETT.