

(19) World Intellectual Property Organization
International Bureau



(43) International Publication Date
6 January 2011 (06.01.2011)

PCT

(10) International Publication Number
WO 2011/001288 A3

(51) International Patent Classification:

C22B 5/02 (2006.01) C22B 23/02 (2006.01)
C22B 5/10 (2006.01) C22B 25/02 (2006.01)
C22B 7/00 (2006.01) C22B 25/06 (2006.01)
C22B 7/04 (2006.01) C21B 15/00 (2006.01)

(21) International Application Number:

PCT/IB2010/001826

(22) International Filing Date:

28 June 2010 (28.06.2010)

(25) Filing Language:

English

(26) Publication Language:

English

(30) Priority Data:

61/213,645 29 June 2009 (29.06.2009) US

(72) Inventor; and

(71) Applicant : LI, Bairong [CN/CN]; Unit 1303, Tower A,
Victory Plaza 101, Tiyu West Road, Tianhe District,
Guangzhou 510620 (CN).

(81) Designated States (unless otherwise indicated, for every
kind of national protection available): AE, AG, AL, AM,
AO, AT, AU, AZ, BA, BB, BG, BH, BR, BW, BY, BZ,

CA, CH, CL, CN, CO, CR, CU, CZ, DE, DK, DM, DO,
DZ, EC, EE, EG, ES, FI, GB, GD, GE, GH, GM, GT,
HN, HR, HU, ID, IL, IN, IS, JP, KE, KG, KM, KN, KP,
KR, KZ, LA, LC, LK, LR, LS, LT, LU, LY, MA, MD,
ME, MG, MK, MN, MW, MX, MY, MZ, NA, NG, NI,
NO, NZ, OM, PE, PG, PH, PL, PT, RO, RS, RU, SC, SD,
SE, SG, SK, SL, SM, ST, SV, SY, TH, TJ, TM, TN, TR,
TT, TZ, UA, UG, US, UZ, VC, VN, ZA, ZM, ZW.

(84) Designated States (unless otherwise indicated, for every
kind of regional protection available): ARIPO (BW, GH,
GM, KE, LR, LS, MW, MZ, NA, SD, SL, SZ, TZ, UG,
ZM, ZW), Eurasian (AM, AZ, BY, KG, KZ, MD, RU, TJ,
TM), European (AL, AT, BE, BG, CH, CY, CZ, DE, DK,
EE, ES, FI, FR, GB, GR, HR, HU, IE, IS, IT, LT, LU,
LV, MC, MK, MT, NL, NO, PL, PT, RO, SE, SI, SK,
SM, TR), OAPI (BF, BJ, CF, CG, CI, CM, GA, GN, GQ,
GW, ML, MR, NE, SN, TD, TG).

Published:

— with international search report (Art. 21(3))

(88) Date of publication of the international search report:

31 March 2011

(54) Title: METAL REDUCTION APPARATUS, METAL REDUCTION SYSTEM AND METALLURGICAL SYSTEM

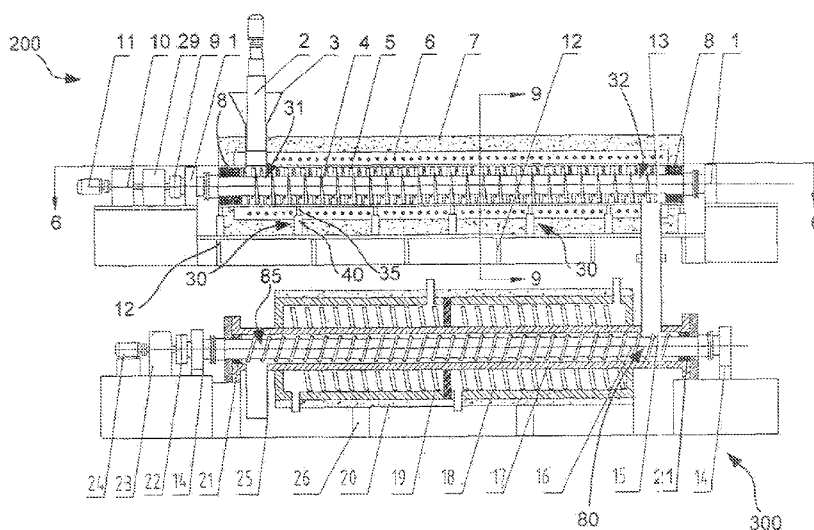

Fig. 5

(57) Abstract: A metal reduction apparatus for recovering at least one metal from at least one metal-containing material is provided. The apparatus comprises a reactor housing configured to receive a mixture of at least one metal-containing material, at least one reducing agent and at least one additive, a heating device including at least one heating unit thermally coupled to the reactor housing, and a propelling blender located in the reactor housing, wherein the propelling blender includes a plurality of shafts, each of the shafts has at least one blade and the thickness of an outer surface of the blade varies along the arc of the blade. A metal reduction system and a metallurgical system comprising the metal reduction apparatus are also provided.



WO 2011/001288 A3

INTERNATIONAL SEARCH REPORT

International application No.

PCT/IB2010/001826

A. CLASSIFICATION OF SUBJECT MATTER

See extra sheet

According to International Patent Classification (IPC) or to both national classification and IPC

B. FIELDS SEARCHED

Minimum documentation searched (classification system followed by classification symbols)

IPC: C21B/-; C22B/-

Documentation searched other than minimum documentation to the extent that such documents are included in the fields searched

Electronic data base consulted during the international search (name of data base and, where practicable, search terms used)

WPI, EPODOC, CNKI, CNPAT: reduce?, reducing, reduction, propel+, screw+, blade?, lamina?, vane?, thickness, heat 2d recover+

C. DOCUMENTS CONSIDERED TO BE RELEVANT

Category*	Citation of document, with indication, where appropriate, of the relevant passages	Relevant to claim No.
X	EP0184405A2 (CANADIAN PATENTS & DEVELOPMENT LTD.) 11 Jun. 1986 (11.06.1986) page 3 paragraph 3 to page 4 paragraph 8, page 5 the last paragraph, page 6 paragraph 2 to page 7 paragraph 2, page 13 paragraph 2 of description; Fig. 1	1-55
A	CN1288485A (SIDMAR NV.) 21 Mar. 2001 (21.03.2001) the whole document	1-55
A	JP2000129326A (KOBE STEEL LTD.) 09 May 2000 (09.05.2000) the whole document	1-55
PX	CN201512566U (LI,Bairong) 23 Jun. 2010 (23.06.2010) the whole document	1-55
PX	CN101613801A (LI,Bairong) 30 Dec. 2009 (30.12.2009) the whole document	1-55

Further documents are listed in the continuation of Box C.

See patent family annex.

<p>* Special categories of cited documents:</p> <p>“A” document defining the general state of the art which is not considered to be of particular relevance</p> <p>“E” earlier application or patent but published on or after the international filing date</p> <p>“L” document which may throw doubts on priority claim (S) or which is cited to establish the publication date of another citation or other special reason (as specified)</p> <p>“O” document referring to an oral disclosure, use, exhibition or other means</p> <p>“P” document published prior to the international filing date but later than the priority date claimed</p>	<p>“T” later document published after the international filing date or priority date and not in conflict with the application but cited to understand the principle or theory underlying the invention</p> <p>“X” document of particular relevance; the claimed invention cannot be considered novel or cannot be considered to involve an inventive step when the document is taken alone</p> <p>“Y” document of particular relevance; the claimed invention cannot be considered to involve an inventive step when the document is combined with one or more other such documents, such combination being obvious to a person skilled in the art</p> <p>“&” document member of the same patent family</p>
--	---

Date of the actual completion of the international search 18 Nov. 2010 (18.11.2010)	Date of mailing of the international search report 06 Jan. 2011 (06.01.2011)
--	--

Name and mailing address of the ISA/CN
The State Intellectual Property Office, the P.R.China
6 Xitucheng Rd., Jimen Bridge, Haidian District, Beijing, China
100088
Facsimile No. 86-10-62019451

Authorized officer
XU, Yuanyuan
Telephone No. (86-10)82245990

INTERNATIONAL SEARCH REPORT

International application No.

PCT/IB2010/001826

Box No. II Observations where certain claims were found unsearchable (Continuation of item 2 of first sheet)

This international search report has not been established in respect of certain claims under Article 17(2)(a) for the following reasons:

1. Claims Nos.:
because they relate to subject matter not required to be searched by this Authority, namely:
2. Claims Nos.:
because they relate to parts of the international application that do not comply with the prescribed requirements to such an extent that no meaningful international search can be carried out, specifically:
3. Claims Nos.:
because they are dependent claims and are not drafted in accordance with the second and third sentences of Rule 6.4(a).

Box No. III Observations where unity of invention is lacking (Continuation of item 3 of first sheet)

This International Searching Authority found multiple inventions in this international application, as follows:

Group I: Claims 1-34 are directed to a metal reduction apparatus comprising a reactor housing, a heating device and a propelling blender with a plurality of shafts and blades, wherein the thickness of an outer surface of the at least one blade varies along the arc of the at least one blade.

Group II: Claims 35-41 are directed to a metal reduction system comprising a metal reduction apparatus and at least one heat recovery device.

Group III: Claims 42-55 are directed to a metallurgical system comprising a material preparation system, a metal reduction apparatus and a separator.

The common technical feature of group I, group II and group III is "a metal reduction apparatus comprising a reactor housing, a heating device and a propelling blender".

The prior art EP0184405A2 discloses (see page 3 paragraph 3 to page 4 paragraph 8 of description; Fig. 1) a process and an apparatus for the smelting reduction of ores. The apparatus comprises: a) a reactor vessel having an inlet to its interior and an outlet therefrom; b) means for delivering a charge to be reduced to the said inlet for conveyance through the interior to the outlet; c) means for receiving a reduced charge from the said outlet; d) a mechanical member movable within the vessel interior to mechanically engage the charge therein during its residence in the vessel and move it from the inlet to the outlet, and means for so moving the mechanical member within the interior; and e) heating means for heating the charge within the reactor vessel interior to the temperature adequate for the reduction of the charge. Preferably the reactor vessel is an elongated tubular container having a longitudinal axis and the mechanical member is a screw conveyor having a longitudinal axis which is embedded in the charge with its longitudinal axis parallel to that of the vessel, the screw conveyor being rotated about its longitudinal axis to move and mix the charge. Preferably also, multiple screw conveyors are provided to convey multiple charges to said reaction vessel interior.

Obviously, the common technical feature of group I, group II and group III is disclosed by D1, therefore, the above three groups are not so related as to constitute a single general inventive concept. Accordingly, unity of invention is lacking.

1. As all required additional search fees were timely paid by the applicant, this international search report covers all searchable claims.
2. As all searchable claims could be searched without effort justifying an additional fees, this Authority did not invite payment of additional fee.
3. As only some of the required additional search fees were timely paid by the applicant, this international search report covers only those claims for which fees were paid, specifically claims Nos.:
4. No required additional search fees were timely paid by the applicant. Consequently, this international search report is restricted to the invention first mentioned in the claims; it is covered by claims Nos.:

- Remark on protest**
- The additional search fees were accompanied by the applicant's protest and, where applicable, the payment of a protest fee.
- The additional search fees were accompanied by the applicant's protest but the applicable protest fee was not paid within the time limit specified in the invitation.
- No protest accompanied the payment of additional search fees.

INTERNATIONAL SEARCH REPORT
Information on patent family members

International application No.
PCT/IB2010/001826

Patent Documents referred in the Report	Publication Date	Patent Family	Publication Date
EP0184405A2	11.06.1986	AU5040585A	12.06.1986
		JP61133330A	20.06.1986
		BR8505996A	19.08.1986
		CN85108811A	10.05.1986
		US4756748A	12.07.1988
		CA1244656A	15.11.1988
		EP0184405B	30.05.1990
CN1288485A	21.03.2001	DE3577995G	05.07.1990
		EP0933434A1	04.08.1999
		WO9939013A1	05.08.1999
		WO9955919A1	04.11.1999
		AU2260299A	16.08.1999
		AU3821499A	16.11.1999
		BR9908369A	28.11.2000
		EP1060274A1	20.12.2000
		EP1080235A1	07.03.2001
		CN1298455A	06.06.2001
		KR20010024881A	26.03.2001
		KR20010043027A	25.05.2001
		BR9910039A	08.01.2002
		JP2002501982T	22.01.2002
		AU742984B	17.01.2002
		JP2002513082T	08.05.2002
		ZA200006043A	24.04.2002
		EP1080235B1	24.07.2002
		US6447713B1	10.09.2002
		DE69902258E	29.08.2002
MXPA00007386A	01.10.2001		
US6488737B1	03.12.2002		
ES2178436T3	16.12.2002		

INTERNATIONAL SEARCH REPORT
Information on patent family members

International application No.
PCT/IB2010/001826

Patent Documents referred in the Report	Publication Date	Patent Family	Publication Date
JP2000129326A	09.05.2000	JP3020482B1	15.03.2000
CN201512566U	23.06.2010	none	
CN101613801A	30.12.2009	none	

INTERNATIONAL SEARCH REPORT

International application No.

PCT/IB2010/001826

Continuation of **CLASSIFICATION OF SUBJECT MATTER:**

C22B5/02 (2006.01) i

C22B5/10 (2006.01) i

C22B7/00 (2006.01) i

C22B7/04 (2006.01) i

C22B23/02 (2006.01) i

C22B25/02 (2006.01) i

C22B25/06 (2006.01) i

C21B15/00 (2006.01) i