



(19) **United States**

(12) **Patent Application Publication**
Heuft et al.

(10) **Pub. No.: US 2002/0023821 A1**

(43) **Pub. Date: Feb. 28, 2002**

(54) **METHOD AND APPARATUS FOR ROTATING ROTATIONALLY SYMMETRICAL CONTAINERS, SUCH AS BOTTLES, WHILE TRANSPORTING THEM UNDER BACKUP PRESSURE**

Related U.S. Application Data

(62) Division of application No. 08/875,393, filed on Jul. 23, 1997, now Pat. No. 6,155,408, which is a 371 of international application No. PCT/EP96/05193, filed on Nov. 25, 1996.

(76) Inventors: **Bernhard Heuft**, Burgbrohl (DE);
Hans-Ulrich Goller, Godesberg (DE)

(30) **Foreign Application Priority Data**

Nov. 24, 1995 (DE)..... 295 18 628.3

Correspondence Address:

GARDNER, CARTON & DOUGLAS
321 N. CLARK STREET
SUITE 3400
CHICAGO, IL 60610 (US)

Publication Classification

(51) **Int. Cl.⁷** **B65G 47/244**
(52) **U.S. Cl.** **198/411**

(57) **ABSTRACT**

Rotationally symmetrical containers (10) are transported under backup pressure on a conveying surface (12) limited laterally by railings (14). For rotating the containers (10) at a predetermined site along the conveying surface (12), one of two consecutive containers (10) is arranged stable against one railing (14) and the other stable against the other railing (14) in the direction of conveyance after the site at which the containers are to rotate.

(*) Notice: This is a publication of a continued prosecution application (CPA) filed under 37 CFR 1.53(d).

(21) Appl. No.: **09/709,889**

(22) Filed: **Nov. 10, 2000**

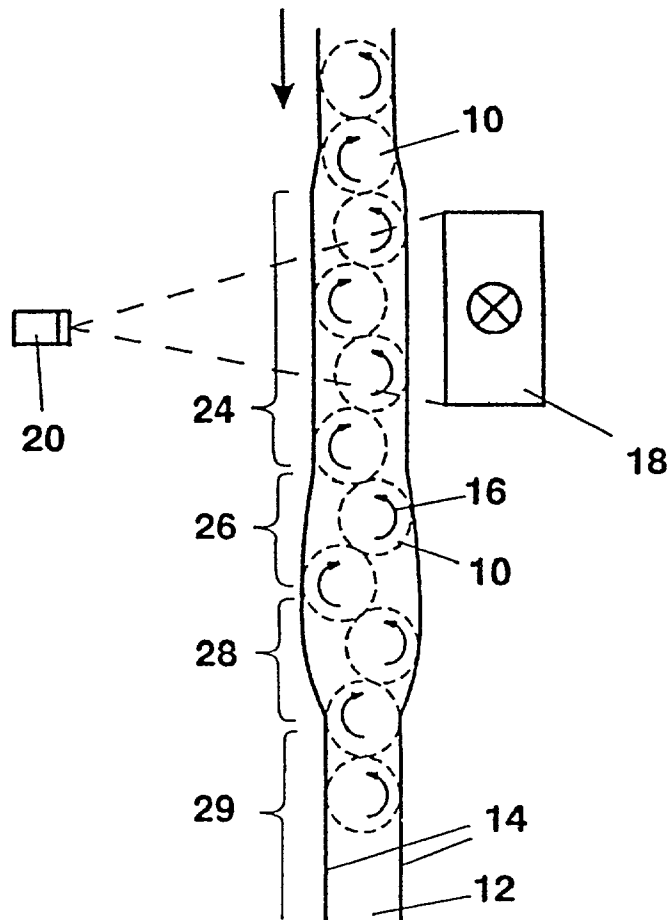

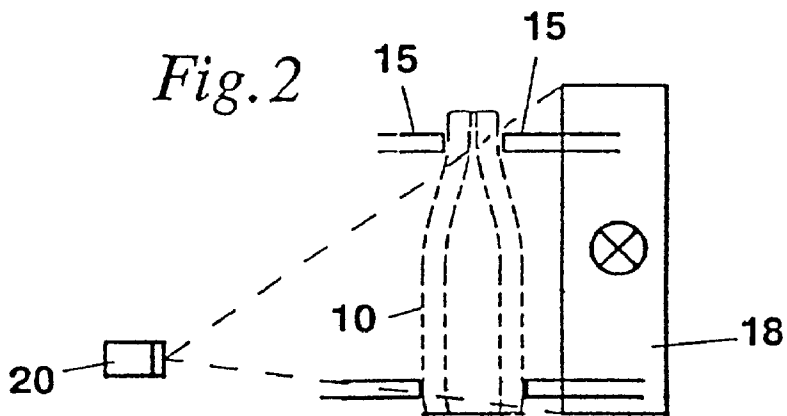
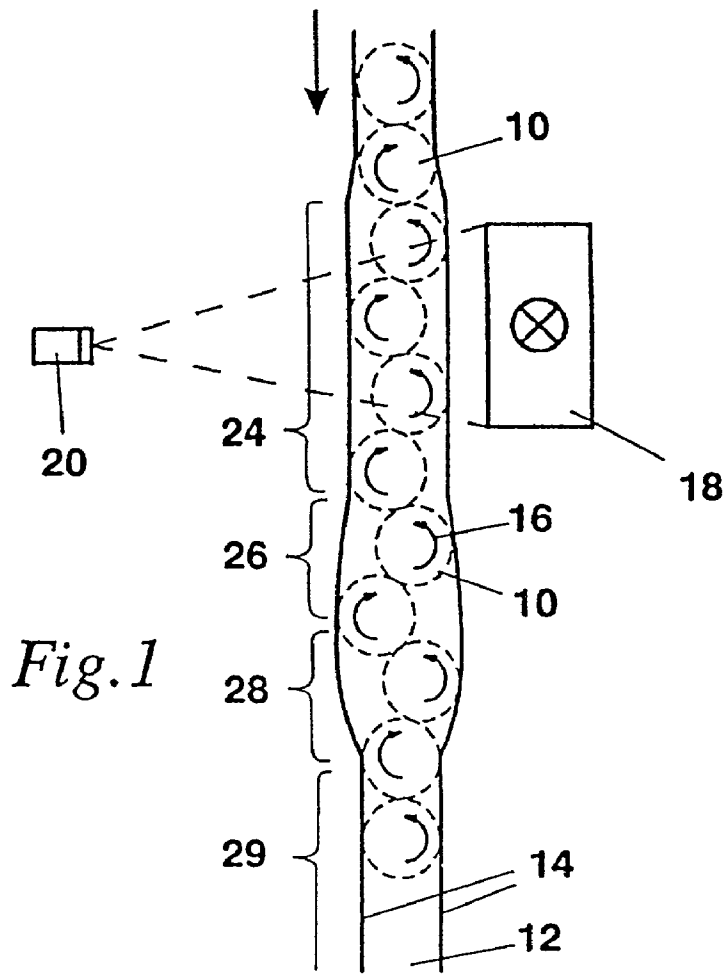

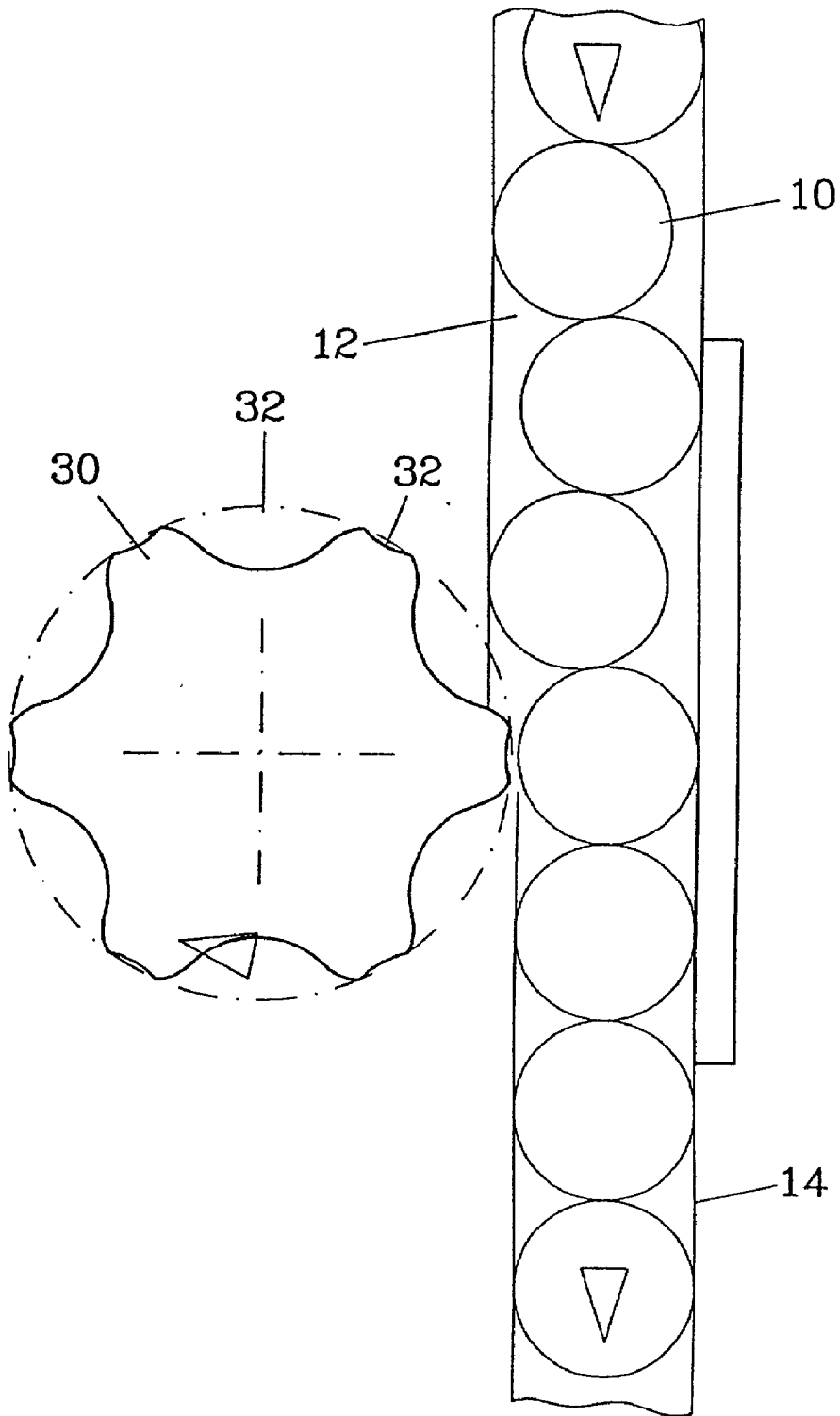

Fig. 3

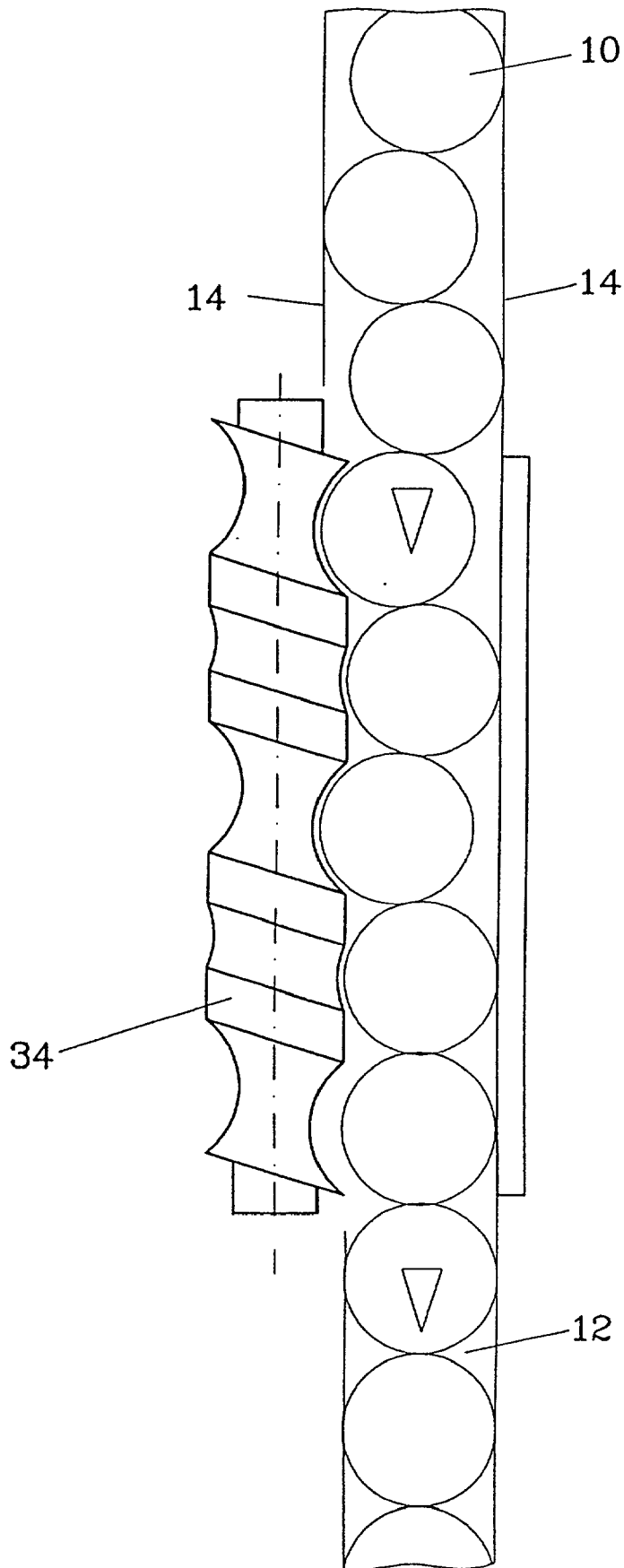
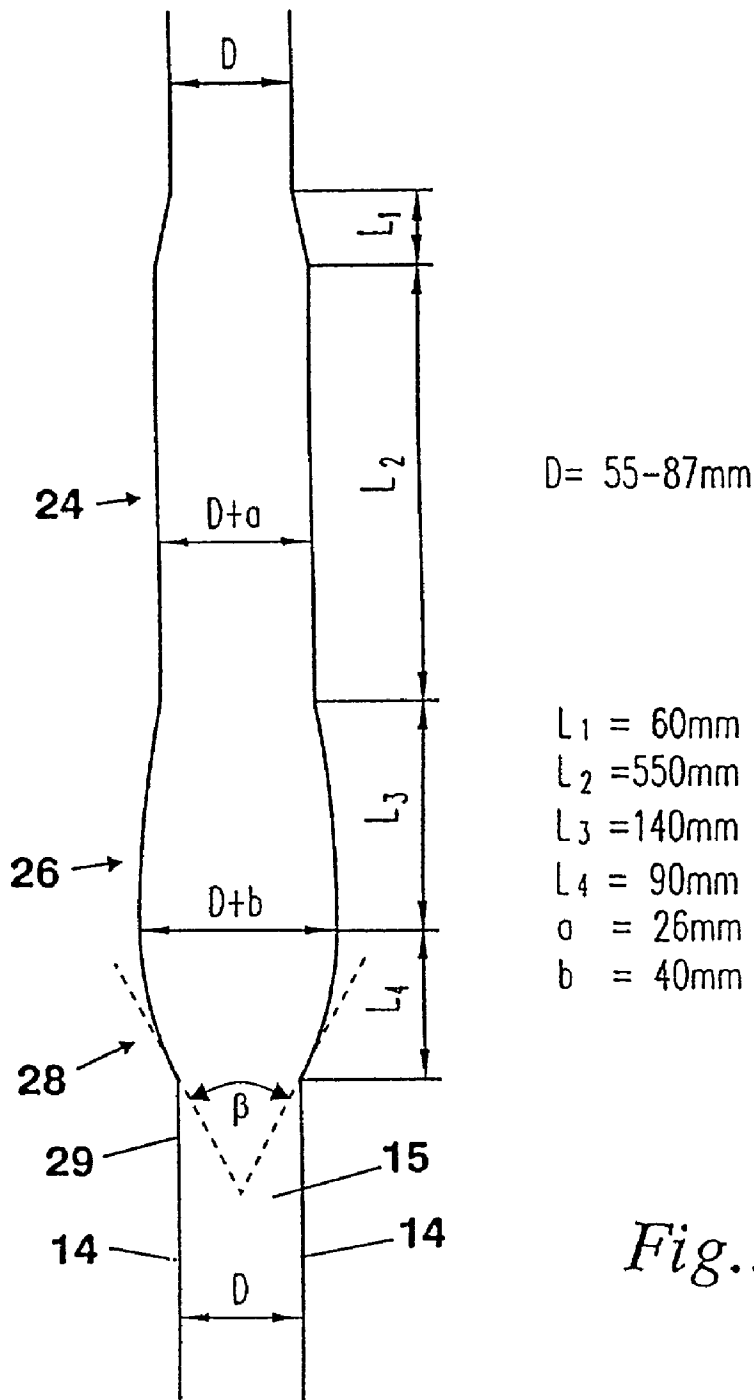

Fig.4



METHOD AND APPARATUS FOR ROTATING ROTATIONALLY SYMMETRICAL CONTAINERS, SUCH AS BOTTLES, WHILE TRANSPORTING THEM UNDER BACKUP PRESSURE

[0001] The invention relates to a method and apparatus for rotating rotationally symmetrical containers, such as bottles, while transporting them on a conveying surface. The containers are transported under backup pressure and are guided during the transportation, for which the conveying surface has a guide device or a railing on each side.

[0002] In particular empty glass or plastic bottles are rotated about their axis for inspecting their side walls. A side wall inspection device is known from EP-A-0 415 154 with which the lateral guide devices consist of belts arranged on both sides of the conveying surface and driven at different speeds so that the empty bottles held between them are rotated about their longitudinal axis. That apparatus requires that the empty bottles have previously been separated or at least guided to the conveying surface free of backup pressure. Therefore, if the empty bottles are not arranged free of pressure, they must be separated.

[0003] The invention is based on the problem of enabling the rotation of containers conveyed under backup pressure about their longitudinal axis in a simple manner.

[0004] This problem is solved according to the method of the invention in that one of two consecutive containers is arranged offset stable to one side and the other stable to the other side seen in the direction of conveyance after the site at which the containers are to rotate.

[0005] The problem is solved within the scope of the apparatus of the invention in that a device is provided for the stable arrangement of one of at least two consecutive containers against the railing and the other container against the other railing in the direction of conveyance after the site at which the containers are to rotate.

[0006] Apparatuses are known from DE-C-843 973 and DE-C-922 519 for transporting empty bottles under backup pressure with which empty bottles are alternately offset to the left and to the right railing. However, with those apparatuses, disturbances that lead to a change in the position of a container from one railing to the other railing propagate from the exit end of the conveying device counter to the direction of transportation. Such a change in position then also leads to a reversal of the direction of rotation of the individual empty bottles so that a defined rotation of the empty bottles is not achievable.

[0007] According to the basic concept of the present invention, a stable arrangement of at least two containers at the left or, resp., right railing prevents such a disturbance and a change in the position of the individual containers caused by that from taking place after those containers.

[0008] All subsequent containers lie stable against one of the two railings and roll along the railing and against each other, the containers rolling alternately along the left and right railing with alternate direction of rotation.

[0009] An apparatus for transporting rotationally symmetrical containers is known from U.S. Pat. No. 2,725,138, the containers backing up at the end of the conveying surface and rolling along the side rails. At the end of the conveying surface, the containers are arranged at defined distances on

a further transporting device by means of a star wheel. Upon being taken over by the star wheel, each container is pushed laterally against the same railing. Hence, the containers which were previously positioned at the other rail change their position. That change of position causes all subsequent containers likewise to change their position and therewith also their direction of rotation.

[0010] The conveying surface can be moving or fixed. Moving conveying surfaces are conveyor belts, chain link conveyers, air cushions, rollers and the like. Fixed conveying surfaces can be simple metal slideways on which the containers are pushed by means of backup pressure, the backup pressure can be produced by a star wheel or a seriesed chain link conveyor.

[0011] In this context, the term "transporter" encompasses all these kinds of conveying surfaces.

[0012] In a first embodiment of the device for stabilizing the position of at least two consecutive containers, the distance between the two railings in the direction of conveyance is to begin with gradually broadened to about 1.5 times the diameter of the containers and then narrowed down at an angle of the two railings to each other of about 30 to 100°, preferably 50 to 80°, to somewhat more than the diameter of the containers. The path of the railings in this area preferably mirrors or is symmetrical to the midline of the transporter.

[0013] The distance between the two railings has an effect on the pressure conditions in the stream of the containers. The following relationships are applicable:

$$\alpha = \arcsin(V/D)$$

$$V = D - d$$

$$F_{1n} = (2 \cdot n - 1) \cdot F_R \cdot \frac{\sin \alpha}{\cos \alpha} = (2 \cdot n - 1) \cdot F_R \cdot \tan \alpha$$

$$F_{2n} = \frac{n \cdot F_R}{\cos \alpha}$$

[0014] V=lateral displacement of consecutive containers;

[0015] D=distance between the lateral rails (width of the transporter);

[0016] d=diameter of the containers;

[0017] α =angle between the connecting line of two consecutive containers and the direction of transportation;

[0018] F_{1n} =the force of the nth container acting on the railing;

[0019] F_{2n} =the force component acting on the subsequent container

[0020] F_R =friction force between container and railing.

[0021] The apparatus works stable in a broad range of the backup pressure. However, in practice, extreme situations which can lead to disturbances in the rotation behavior of the container result due to most varied influences. Those influences can be allayed by additional measures so that a

disturbance of the operation is largely prevented. Very strong pressure at the upstream end of the apparatus can be reduced by a mechanical resistance in the course of the transporter before the apparatus. For example, there can be arranged on the transporter a thin metal sheet over which the containers slide and thereby undergo an additional friction. Baffles which reduce the pressure peaks can also be built up by means of the side railings. The backup pressure is also reduced by the apparatus of the invention itself so that the backup pressure for a subsequent apparatus is reduced by a preceding apparatus. If, vice versa, too low a backup pressure exists, the container can be imparted a force acting in the direction of transportation by a laterally arranged belt running along with it.

[0022] By narrowing the distance between the railings at a relatively large angle, it is achieved that in the case that a container at the section of the transporter again narrowed down changes its position from one railing to the other, this does not have any influence on the position of the subsequent container still within the narrowing area. That is to say, the pressure point between the two containers shifts so slightly due to the narrow free movement area of the preceding container that the subsequent container is not forced to change its position to the other railing. The chaotic behavior of the containers is therewith interrupted and a clear and stable arrangement of the containers is attained.

[0023] In a second embodiment, the device for stabilizing the position of at least two consecutive containers is a star wheel that is arranged rotatable about a vertical axis adjacent to the transporter and has cutouts on its perimeter of alternately different depth that are distributed to correspond to about the diameter of the containers such that the teeth push every second container against the opposite railing while the intermediate containers rest against the adjacent railing due to the cutouts. Two such star wheels can also be arranged meshing on the left and right adjacent to the transporter, the containers then passing through between the two star wheels.

[0024] A stable arrangement of the containers is also possible alternately at the one and the other railing by means of a worm arranged adjacent to the transporter.

[0025] The distance between the two railings is normally only slightly, e.g. 1 to 10 mm, greater than the diameter of the containers. For transportation purposes, such a distance between the railings was hitherto viewed to be sufficient, and the containers jumping back and forth from one railing to the other and the associated change of rotational direction during transport was accepted as being unavoidable. This chaotic behavior can be prevented by the invention. In the area in which each container is to have a defined position and rotational direction proceeding from the stabilization device counter to the direction of conveyance, the distance between the railings is there preferably greater than the distance quoted above and is about 1.2 to 1.6 times, preferably 1.4 to 1.5 times, the diameter of the containers.

[0026] Within this area with increased distance between the railings on the two sides, the containers alternately rotate in opposite directions about their vertical axis and at the same time each roll alternately along the left and right railings. The stability of the position of the containers is also improved by the friction of the containers against each other being greater than the friction between them and the under-surface, i.e., the transporter, and the railings.

[0027] The device according to the invention can be used generally when the containers must rotate when they are handled and inspected.

[0028] The apparatus according to the invention can be used for all types of container inspections that require an unrolling of the surface of or a rotation of containers, e.g. to monitor the placement of labels, the mouth or thread, to check the rotational symmetry of the containers, to monitor the side wall, etc., further devices then not being required to rotate the containers. The side walls are there expediently inspected in an area in which the containers (viewed from the side) overlap as little as possible but have already assumed a stable position against one of the two railings. This is generally the area in which the distance between the two railings is about about 1.2 times the bottle diameter.

[0029] The apparatus according to the invention can, however, also be used to avoid container noise and wear in the congestion area of transporting devices. The noise and the wear are substantially reduced by the containers rolling against each other and the railings in a controlled manner. When the apparatus according to the invention is used for this purpose over longer distances, it can be expedient to distribute several of the apparatuses over the distance, e.g. at railings that are far apart (about 1.5 times the bottle diameter) which can be provided with a soft surface for additional reduction of noise and wear.

[0030] Furthermore, as a result of the controlled surface unrolling of rotationally symmetrical bodies, the apparatus according to the invention can also be used for printing, coating or applying films, labels or caps to containers. The purposive removal of films, labels or caps is similarly possible with the apparatus according to the invention. It is further of advantage with the apparatus according to the invention that most of the bottle filling machines used at present require backup pressure at their feed area. Therefore, due to the apparatus according to the invention, not only do the bottles not have to be separated before the side wall inspection device, rather is the device for producing the backup pressure before the filling machine also not needed.

[0031] Embodiment examples of the invention are explained in the following with reference to the drawings in which:

[0032] FIG. 1 is a top view of the apparatus for rotating empty bottles in conjunction with a device for side wall inspection;

[0033] FIG. 2 is a vertical section of the apparatus of FIG. 1 viewed in the direction of the transporter;

[0034] FIG. 3 is a top view of another embodiment example of the apparatus for rotating containers;

[0035] FIG. 4 a further embodiment example of the apparatus for rotating containers and

[0036] FIG. 5 the course of the railing for bottles with a diameter of 55-87 mm.

[0037] In accordance with FIG. 1, empty bottles 10 are transported on a transporter 12, e.g. a conveyer belt or a link conveyer, in the direction of the arrow. On each side of the transporter 12 is a fixed railing 14 to hold the empty bottles 10 on the transporter 12 even when there is backup pressure. As indicated by the individual arrows 16, the bottles 10

rotate alternately in opposite direction due to their mutual contact and their contact with the railings **14**, the bottles **10** alternately resting against the left and right railings **14**.

[0038] An inspection station to inspect the side walls of the bottles **10** is provided that has a radiation source **18** arranged adjacent to the transporter **12** and a detection device **20**, e.g. a CCD camera, arranged on the opposite side. Both are constructed and operate in the usual manner and are, therefore, not described in more detail. Within the normal transportation area, the railing **14** is located at about a half the height of the empty bottles **10**. In the area of the inspection station, the railing **14** is arranged lower so that the empty bottles **10** are held by the railing **14** at their bottom edges. The empty bottles are guided at the top at their necks by an additional railing **15** (FIG. 2). One of the two railings **14**, **15**, preferably the lower railing **14**, can be provided with a higher friction coating. The empty bottles **10** then slide along the upper railing **15**. If the apparatus according to the invention is used in conjunction with an apparatus for inspecting the base of the containers as according to the simultaneously filed PCT application, "Method and apparatus for transporting containers past an apparatus for inspecting the base of the containers" (our reference: 30562/Bodeninspektion), this additional railing **15** can be an extension of the neck guide according to FIG. 2 of this simultaneously filed utility model application. The containers found to be faulty in the base inspection or the side wall inspection can be separated out by an apparatus according to the likewise simultaneously filed PCT application "Apparatus for separating individual or a plurality of rotationally symmetrical containers from a stream of rotationally symmetrical containers conveyed under backup pressure and cylinder having a piston extensible in a controlled manner" (our reference: 30561/Löffel).

[0039] When empty bottles are transported under backup pressure on a transporter at substantially unchanging distance between the lateral railings, the position of the bottles is unstable, i.e. the bottles now and then jump chaotically from one railing to the opposite railing or change their rotational direction. It is achieved by the apparatus according to the invention that the individual bottles **10** rest stably against one of the two railings **14** within a certain area and retain their rotational direction. The distance between the two railings **14** at the exit of the apparatus is there somewhat more than the diameter of the bottles **10**, as is customary for transporting under backup pressure. This distance is then increased to 1.2 to 1.3 times the diameter of the bottles **10** within a length corresponding to about the diameter of the bottles **10**. This increased distance is then maintained within a first area **24** whose length depends on the circumstances involved. It is sufficient for a side wall inspection when the length of this first area **24** corresponds to about 4 times the bottle diameter. In the following second area **26**, the distance between the railings **14** gradually increases, i.e. within a length corresponding to about 2 to 3 times the bottle diameter, to 1.5 times the bottle diameter and then reduces within a substantially shorter third area **28**, whose length corresponds to about 1.5 times the bottle diameter, to the initial length of somewhat more than the bottle diameter.

[0040] Disturbances in the position of the bottles **10** generally arise at the exit end of a transporter, e.g. by removing a bottle, and then propagate counter to the direction of conveyance. If the last bottle changes its position

from left to right, the pressure point changes with respect to the last bottle but one so that it jumps from right to left and this change in position then propagates counter to the direction of conveyance over the entire length of the transporter. Since the bottles at the exit end of the third area **28** are very markedly offset from each other, and in particular the last bottle **11** within the third area **28** is offset relatively far to the side of the following bottle **10** that is in the again narrow area **29** subsequent thereto, the pressure point between these two bottles does not change so markedly when the bottle in the narrow area **29** changes its position that the last bottle in the third area **28** changes its position toward the other railing **14**.

[0041] In FIG. 5, the course of the railings **14** is shown for a transporter **12** with which bottles are transported whose diameter D ranges from 55 to 87 mm. L_2 is the length of the first area **24**, L_3 that of the second area **26** and L_4 that of the third area **28**. The lateral distance between the railings at the inlet and outlet (area **29**) is a few millimeters greater than the bottle diameter D .

[0042] FIG. 2 shows a section of the device for side wall inspection viewed counter to the direction of transportation. The side wall inspection is arranged in the first area **24** because the distance between the railings **14** is there only about 1.2 to 1.3 times the bottle diameter so that the bottles **10** overlap only slightly viewed from the side. The field of vision of the camera is selected such that several bottles **10** are comprised simultaneously and a complete unrolling of the side wall of each bottle within the field of vision of the camera results due to the rotation of each bottle. Each point on the surface of the bottle can therewith be examined at least once.

[0043] FIG. 3 shows an embodiment example with which the device for stabilizing the position and rotational direction of the containers **10** is formed by a star wheel **30** arranged adjacent to the transporter **12** and rotatable about a vertical axis. The star wheel **30** is divided into sections equal to about the diameter of the containers **10** and has cutouts **32** of alternately different depth. Due to this design, the star wheel **30** presses each second container **10** against the opposite railing so that the intermediate containers **10** necessarily rest against the railing **14** close to the rotary axis of the star wheel **30**. Due to this obligatory positioning of the containers **10** by the star wheel **30**, a disturbance cannot propagate counter to the direction of transportation beyond the star wheel **30**. Each container **10** can also be held between two star wheels **30**.

[0044] FIG. 4 shows a similar embodiment example, the device for stabilizing the position and rotational direction of the containers **10** is a worm **34** arranged adjacent to the transporter **12** and having an approximately horizontal rotary axis. The worm has threads with alternately different depth so that each second container **10** is pushed against the opposite railing. In this case, too, it is in turn possible to arrange a worm **34** at both sides of the transporter **12**.

1. Method for rotating rotationally symmetrical containers (**10**) at a predetermined site along a conveying surface (**12**) which is limited laterally by railings (**14**) and on which the containers (**10**) are transported under backup pressure, characterized in that one of two consecutive containers (**10**) is arranged stable against one railing (**14**) and the other stable

against the other railing (14) in the direction of conveyance after the site at which the containers are to rotate.

2. Apparatus for carrying out a method according to claim 1, characterized in that a stabilizing device for the stable arrangement of one of at least two consecutive containers (10) at one railing (14) and of the other container (10) at the other railing (14) is provided at the exit of the apparatus.

3. Apparatus according to claim 2, characterized in that the distance between the railings (14) is about 1.2 to 1.5 times the diameter of the container in the area of the conveying surface (12) preceding the stabilizing device.

4. Apparatus according to claims 2 or 3, characterized in that the stabilizing device is formed by the distance of the two lateral railings (14) between each other in the direction of conveyance increases to about 1.5 times the diameter of the containers (10) and then reduces at an angle of the lateral railings (14) to each other of about 30 to 100°, preferably 50 to 80°, to about somewhat more than the diameter of the containers (10).

5. Apparatus according to claim 4, characterized in that the two lateral railings (14) run symmetrical to the midline of the conveying surface in the area in which their distance between each other reduces at angle of about 30 to 100°.

6. Apparatus according to claim 2 or 3, characterized in that the stabilizing device is formed by a star wheel (30)

which is arranged adjacent to the conveying surface (12), is freely rotatable about a vertical axis and lays every second container (10) against the opposite railing (14).

7. Apparatus according to claims 2 or 3, characterized in that the stabilizing device is formed by a worm (34) which is arranged adjacent to the transporter (12), has an about vertical axis and has threads of alternately different depth, their arrangement being such that the threads with lesser depth lay each second container (10) against the opposite railing (14).

8. Apparatus for inspection of the side wall or for monitoring the labels of rotating containers (10) which are transported on a transporter (12.) and comprising a radiation source (18) on one side of the transporter (12) and an identification device (20) on the other side of the transporter (12), characterized in that the containers (10) are rotated by a device according to claims 2 to 7 within the visual field of the detection device (20).

9. Apparatus for transporting rotationally symmetrical containers (10) on a conveying surface (12) under backup pressure, a railing (14) being arranged on each side of the conveying surface (12), characterized by at least one device according to one of claims 2 to 7.

* * * * *