



US 20100141665A1

(19) **United States**

(12) **Patent Application Publication**
Madruga et al.

(10) **Pub. No.: US 2010/0141665 A1**

(43) **Pub. Date: Jun. 10, 2010**

(54) **SYSTEM AND METHOD FOR
PHOTOREALISTIC IMAGING WORKLOAD
DISTRIBUTION**

(22) Filed: **Dec. 6, 2008**

Publication Classification

(75) Inventors: **Joaquin Madruga**, Round Rock,
TX (US); **Barry L. Minor**, Austin,
TX (US); **Mark R. Nutter**, Austin,
TX (US)

(51) **Int. Cl.**
G06F 15/80 (2006.01)

(52) **U.S. Cl.** **345/505**

(57) **ABSTRACT**

Correspondence Address:
IBM Corporation (PEC)
c/o Patrick E. Caldwell, Esq.
The Caldwell Firm, LLC, PO Box 59655
DALLAS, TX 75229-0655 (US)

A graphics client receives a frame, the frame comprising scene model data. A server load balancing factor is set based on the scene model data. A prospective rendering factor is set based on the scene model data. The frame is partitioned into a plurality of server bands based on the server load balancing factor and the prospective rendering factor. The server bands are distributed to a plurality of compute servers. Processed server bands are received from the compute servers. A processed frame is assembled based on the received processed server bands. The processed frame is transmitted for display to a user as an image.

(73) Assignee: **INTERNATIONAL BUSINESS
MACHINES**, Armonk, NY (US)

(21) Appl. No.: **12/329,586**

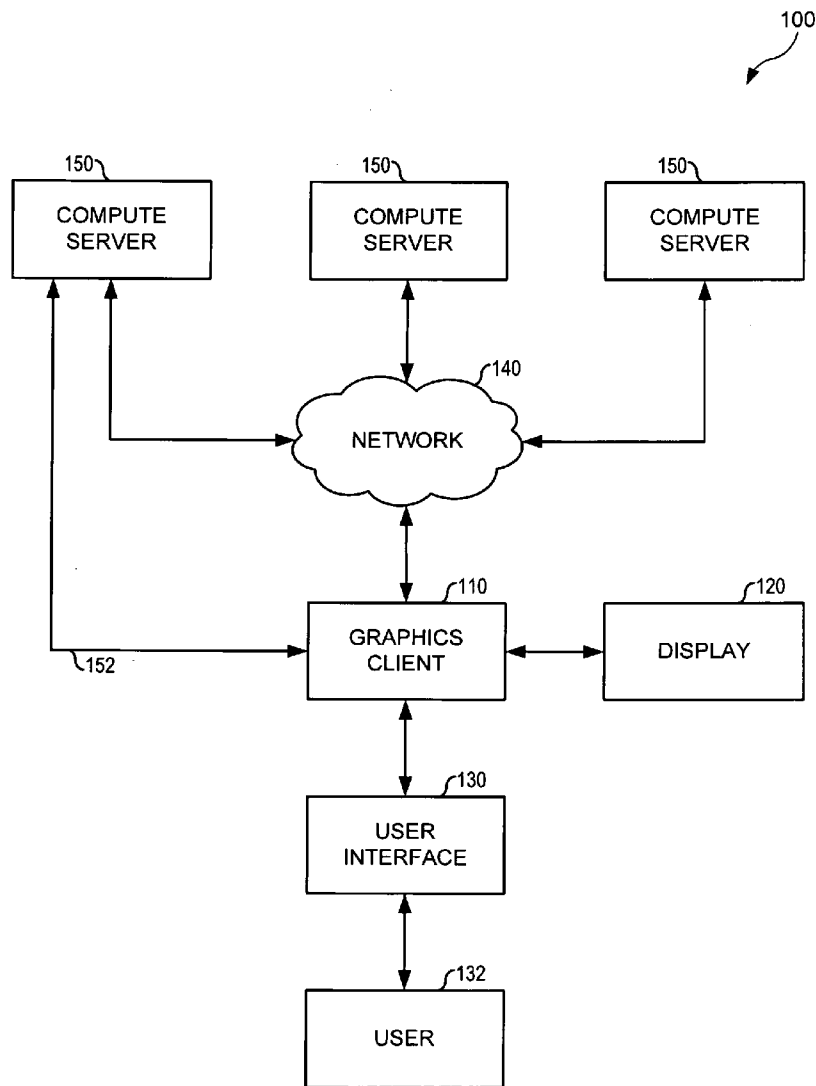
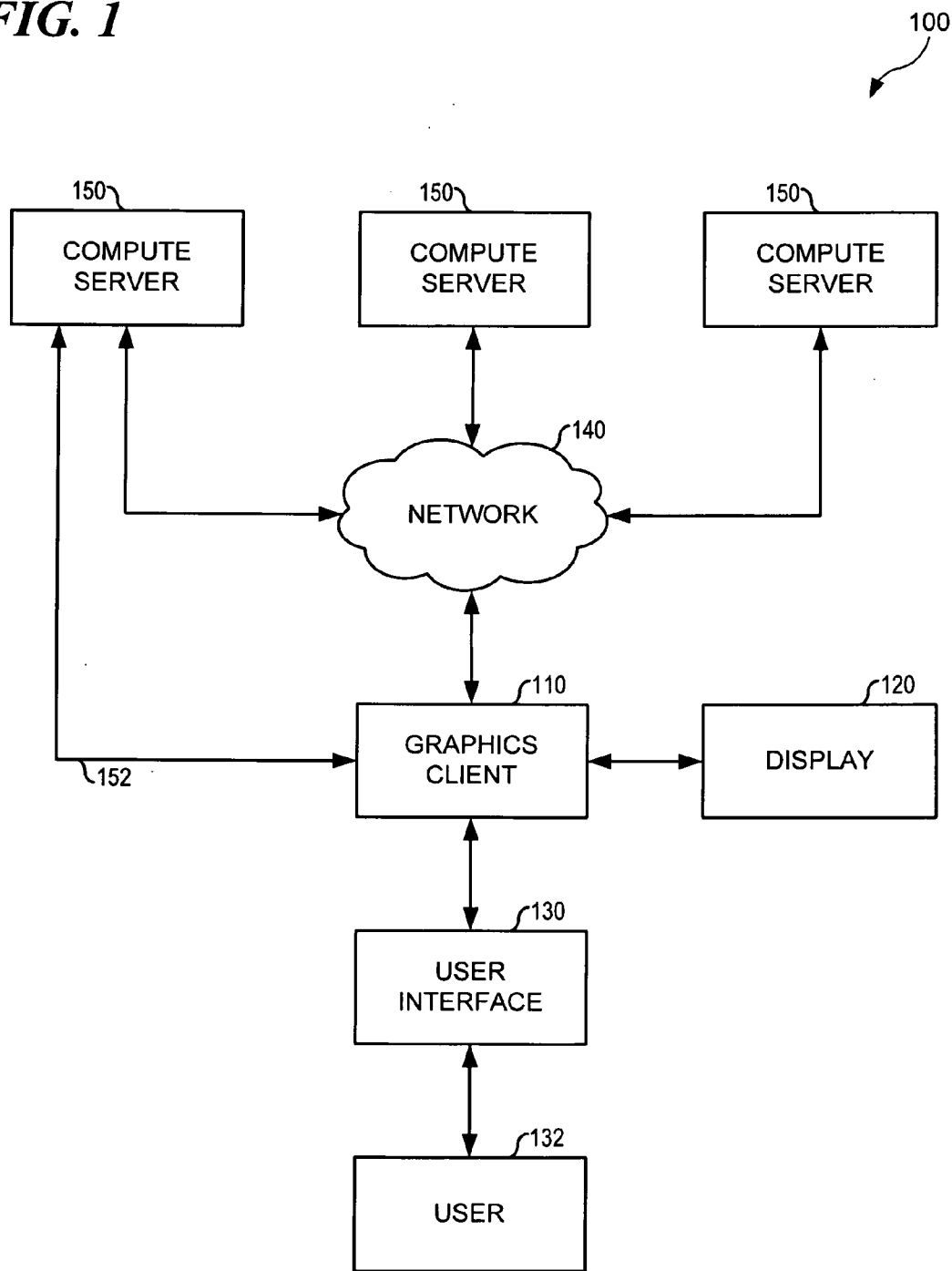
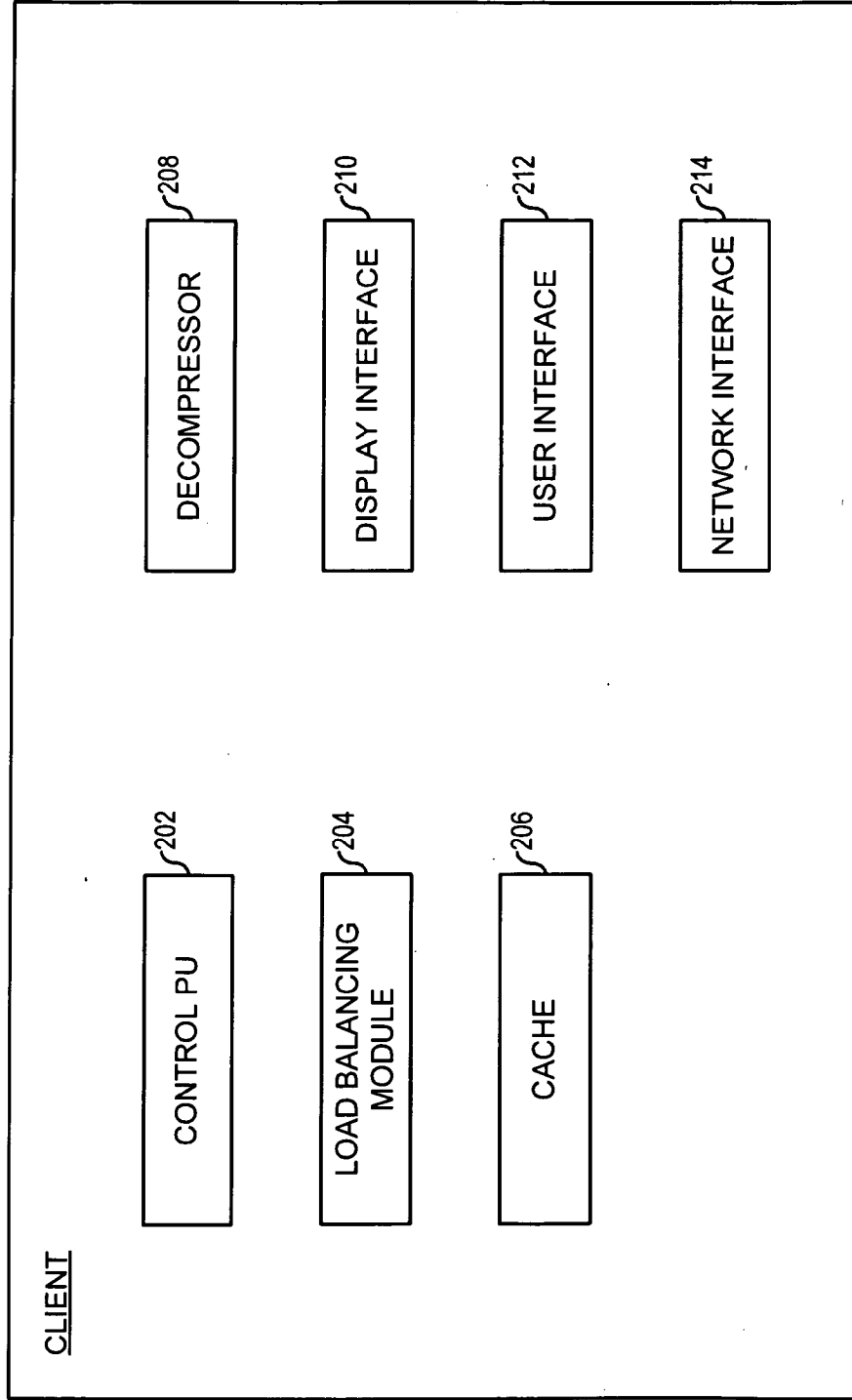

FIG. 1



200

FIG. 2



300

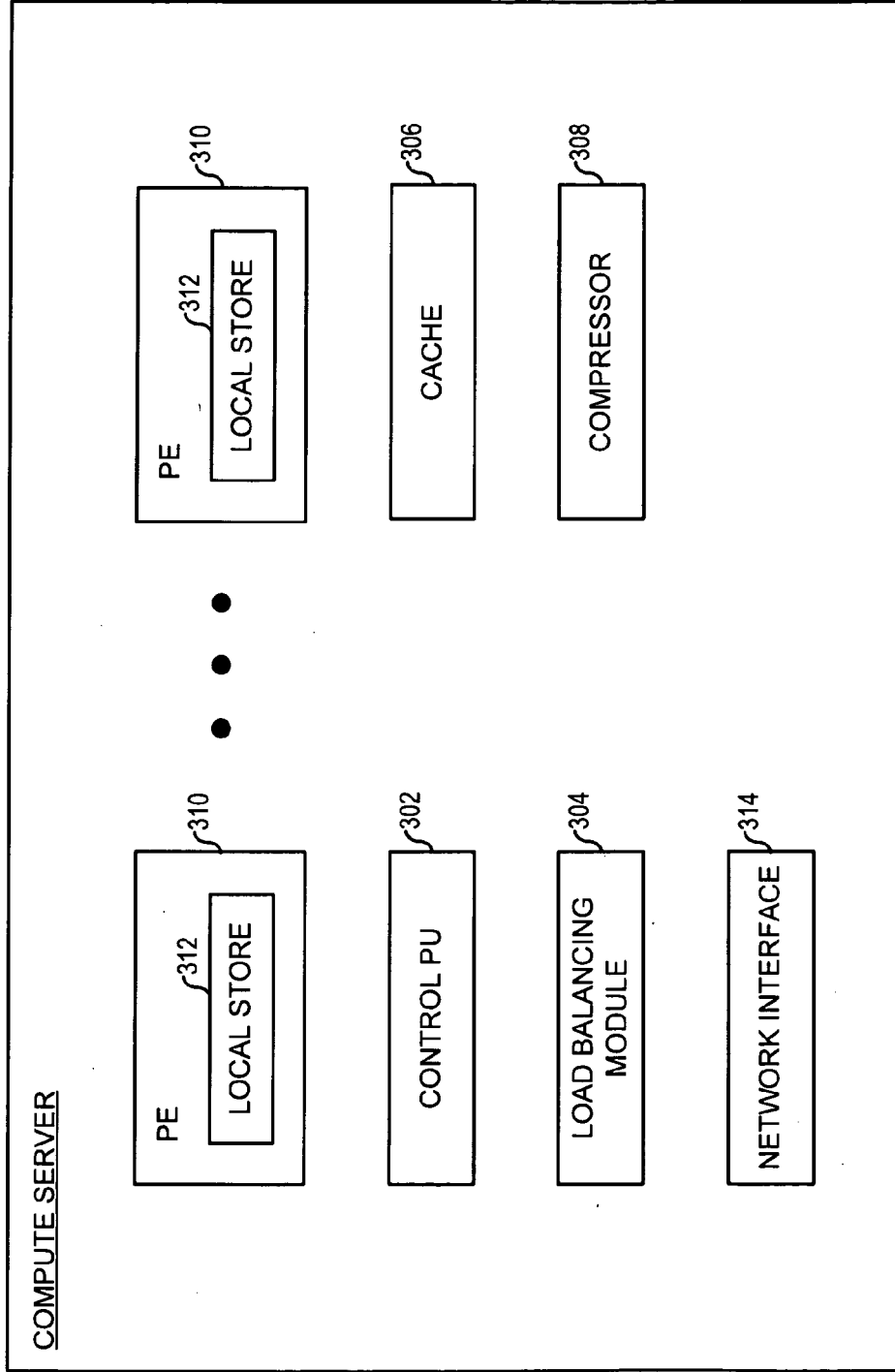

FIG. 3

FIG. 4

400

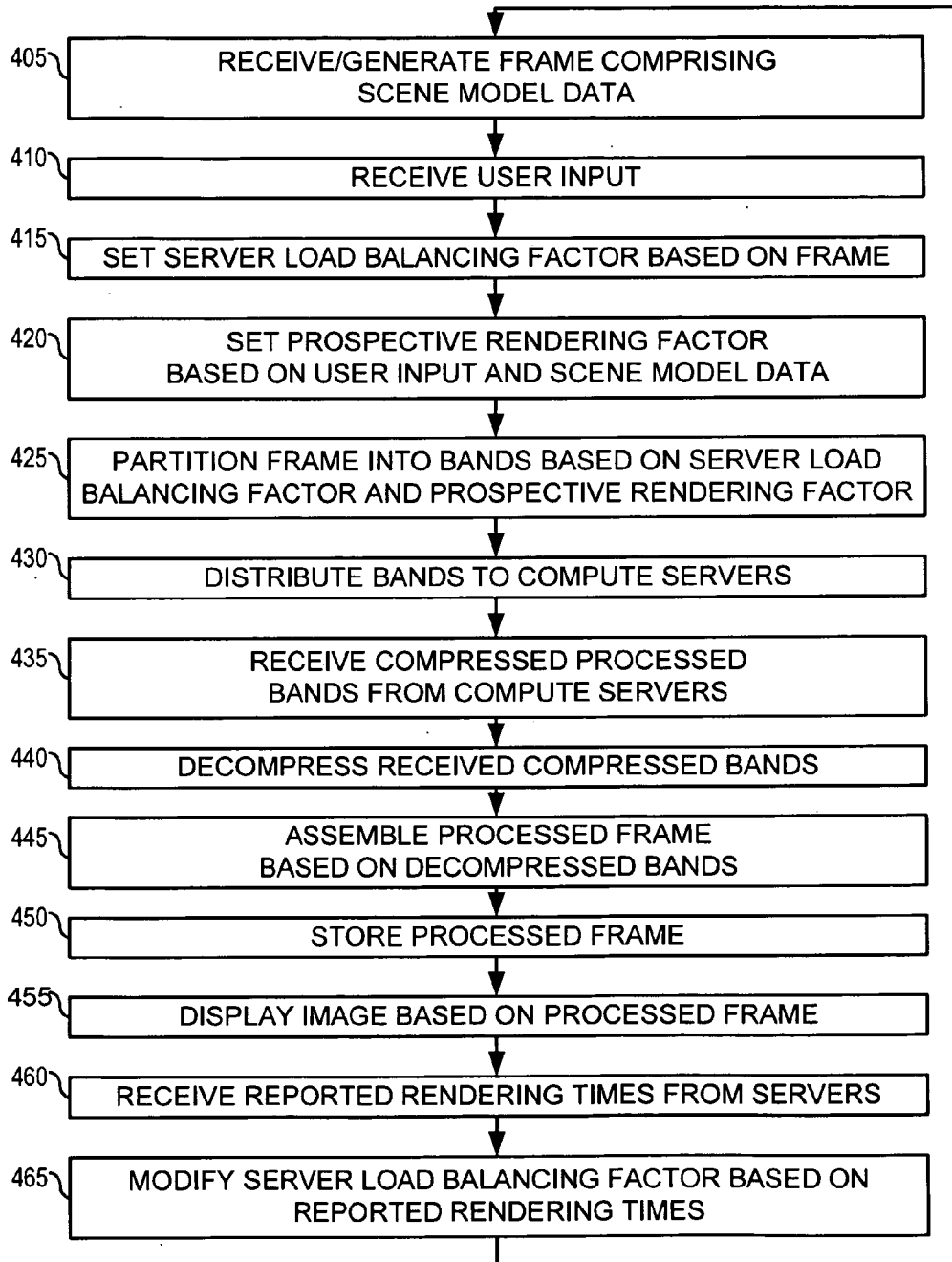
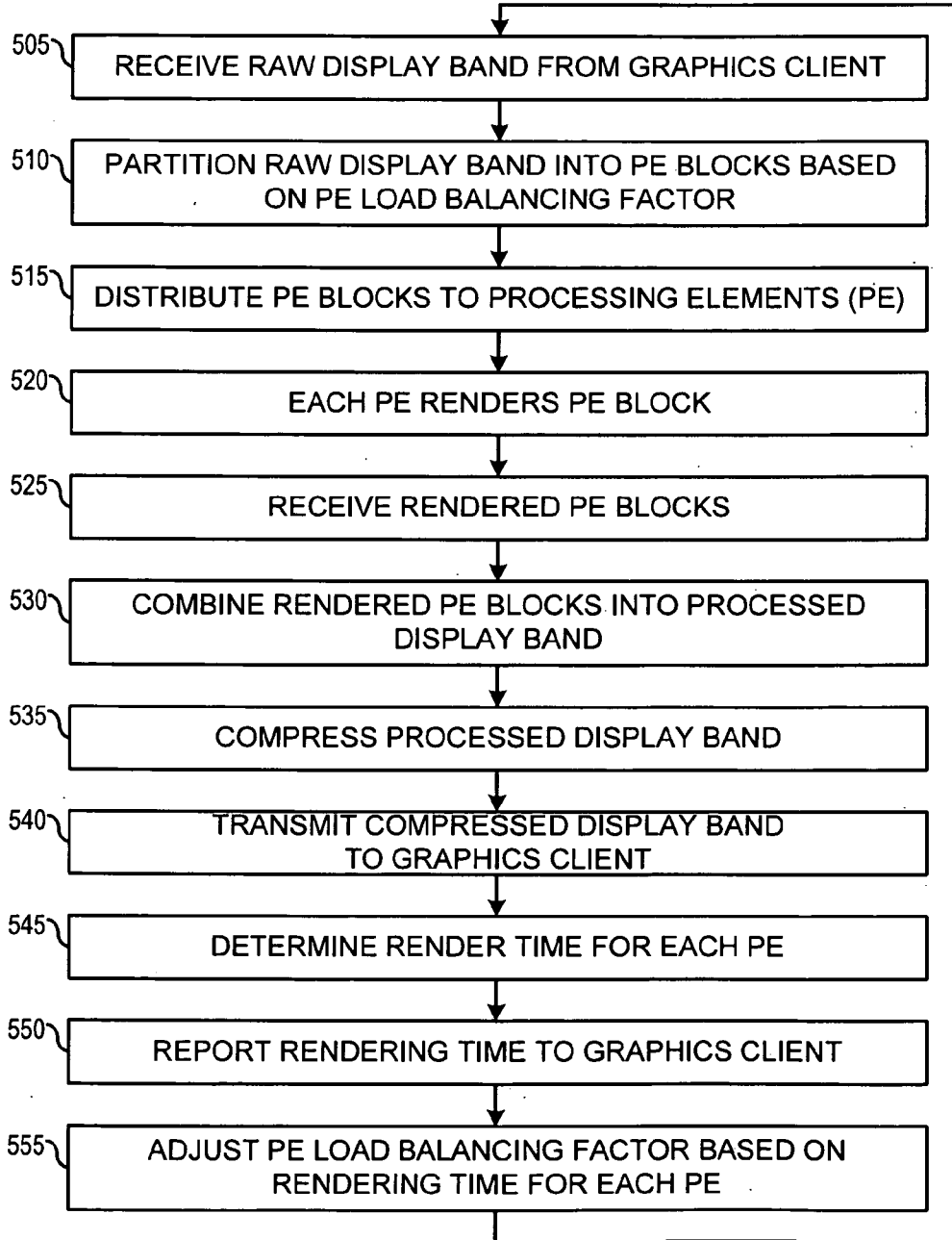

FIG. 5

500



600

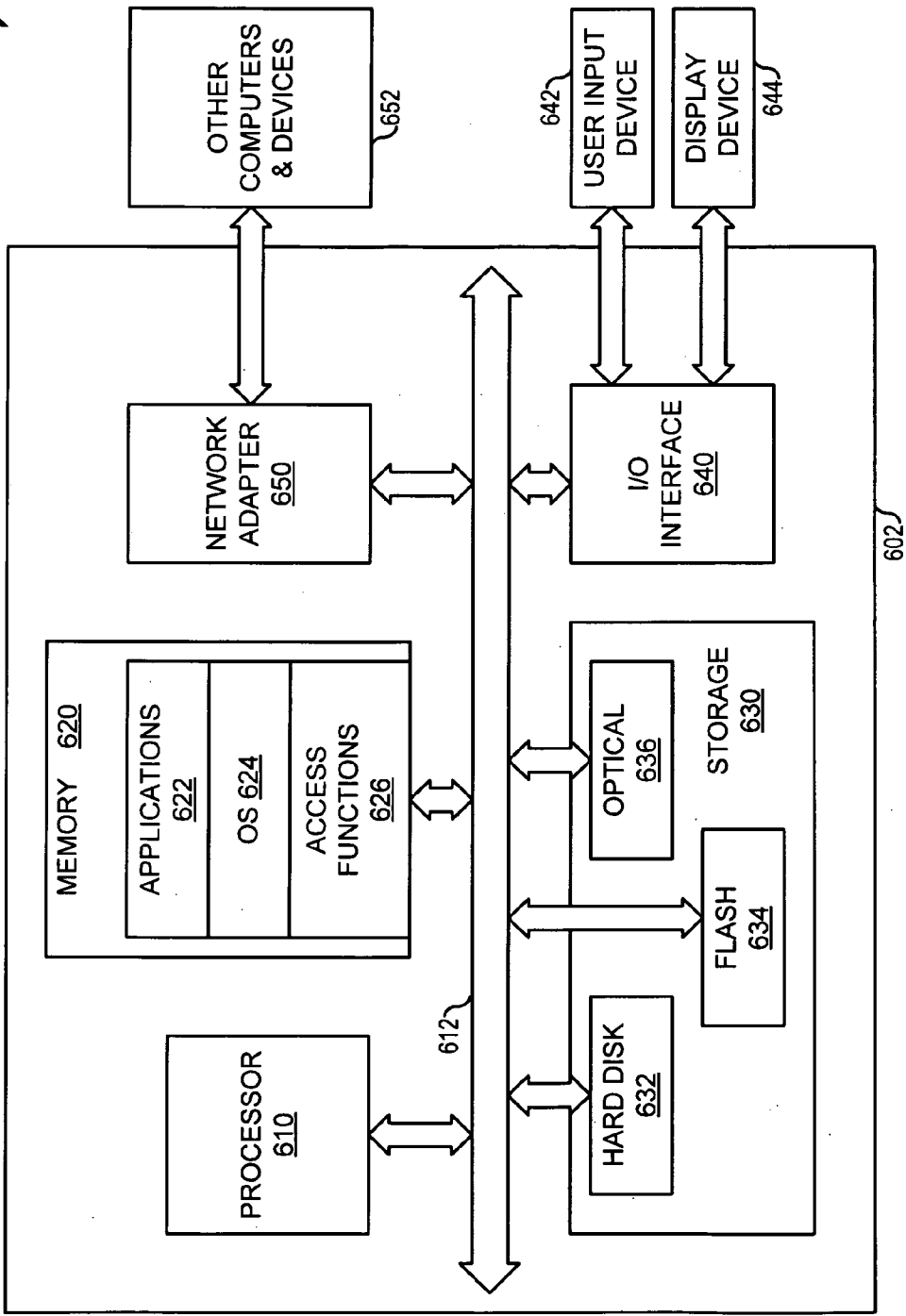

FIG. 6

**SYSTEM AND METHOD FOR
PHOTOREALISTIC IMAGING WORKLOAD
DISTRIBUTION**

TECHNICAL FIELD

[0001] The present invention relates generally to the field of computer networking and parallel processing and, more particularly, to a system and method for improved photorealistic imaging workload distribution.

BACKGROUND OF THE INVENTION

[0002] Modern electronic computing systems, such as microprocessor systems, are often configured to divide a computationally-intensive task into discrete sub-tasks. For heterogeneous systems, some systems employ cache-aware task decomposition to improve performance on distributed applications. As technology advances, the gap between fast local caches and large slower memory widens, and caching becomes even more important. Generally, typical modern systems attempt to distribute work across multiple processing elements (PEs) so as to improve cache hit rates and reduce data stall times.

[0003] For example, ray tracing, a photorealistic imaging technique, is a computationally expensive algorithm that usually does not have fixed data access patterns. However, ray tracing tasks can nevertheless have a very high spatial and temporal locality. As such, a cache aware task distribution for ray tracing applications can lead to high performance gains.

[0004] But typical ray tracing approaches cannot be configured to take full advantage of cache aware task distribution. For example, current ray tracers decompose the rendering problem by breaking up an image into tiles. Typical ray tracers either expressly distribute these tiles among computational units or greedily reserve the tiles for access by the PEs through work stealing.

[0005] Both of these approaches suffer from significant disadvantages. In typical express distribution systems, the additional workload required to manage the distribution of tiles inhibits performance. In some cases, this additional workload can mitigate any gains achieved through managed distribution.

[0006] In typical work-stealing systems, each PE grabs new tiles after it has processed its prior allotment. But since the PEs grab the tiles from a general pool, the tiles are less likely to have a high spatial locality. Thus, in a work-stealing system, the PEs regularly flush their caches with new scene data and are therefore cold for the next frame, completely failing to take any advantage of the task's spatial locality.

BRIEF SUMMARY

[0007] The following summary is provided to facilitate an understanding of some of the innovative features unique to the embodiments disclosed and is not intended to be a full description. A full appreciation of the various aspects of the embodiments can be gained by taking into consideration the entire specification, claims, drawings, and abstract as a whole.

[0008] A graphics client receives a frame, the frame comprising scene model data. A server load balancing factor is set based on the scene model data. A prospective rendering factor is set based on the scene model data. The frame is partitioned into a plurality of server bands based on the server load balancing factor and the prospective rendering factor. The

server bands are distributed to a plurality of compute servers. Processed server bands are received from the compute servers. A processed frame is assembled based on the received processed server bands. The processed frame is transmitted for display to a user as an image.

[0009] In an alternate embodiment, a system comprises a graphics client. The graphics client is configured to receive a frame, the frame comprising scene model data; set a server load balancing factor based on the scene model data; set a prospective rendering factor based on the scene model data; partition the frame into a plurality of server bands based on the server load balancing factor and the prospective rendering factor; distribute the plurality of server bands to a plurality of compute servers; receive processed server bands from the plurality of compute servers; assemble a processed frame based on the received processed server bands; and transmit the processed frame for display to a user as an image.

BRIEF DESCRIPTION OF THE DRAWINGS

[0010] The accompanying figures, in which like reference numerals refer to identical or functionally-similar elements throughout the separate views and which are incorporated in and form a part of the specification, further illustrate the embodiments and, together with the detailed description, serve to explain the embodiments disclosed herein.

[0011] FIG. 1 illustrates a block diagram showing an improved photorealistic imaging system in accordance with a preferred embodiment;

[0012] FIG. 2 illustrates a block diagram showing an improved graphics client in accordance with a preferred embodiment;

[0013] FIG. 3 illustrates a block diagram showing an improved compute server in accordance with a preferred embodiment;

[0014] FIG. 4 illustrates a high-level flow diagram depicting logical operational steps of an improved photorealistic imaging workload distribution method, which can be implemented in accordance with a preferred embodiment;

[0015] FIG. 5 illustrates a high-level flow diagram depicting logical operational steps of an improved photorealistic imaging workload distribution method, which can be implemented in accordance with a preferred embodiment; and

[0016] FIG. 6 illustrates a block diagram showing an exemplary computer system that can be configured to incorporate one or more preferred embodiments.

DETAILED DESCRIPTION

[0017] The particular values and configurations discussed in these non-limiting examples can be varied and are cited merely to illustrate at least one embodiment and are not intended to limit the scope of the invention.

[0018] In the following discussion, numerous specific details are set forth to provide a thorough understanding of the present invention. Those skilled in the art will appreciate that the present invention may be practiced without such specific details. In other instances, well-known elements have been illustrated in schematic or block diagram form in order not to obscure the present invention in unnecessary detail. Additionally, for the most part, details concerning network communications, electro-magnetic signaling techniques, user interface or input/output techniques, and the like, have been omitted inasmuch as such details are not considered necessary to obtain a complete understanding of the present invention, and

are considered to be within the understanding of persons of ordinary skill in the relevant art.

[0019] As will be appreciated by one skilled in the art, the present invention may be embodied as a system, method or computer program product. Accordingly, the present invention may take the form of an entirely hardware embodiment, an entirely software embodiment (including firmware, resident software, micro-code, etc.) or an embodiment combining software and hardware aspects that may all generally be referred to herein as a “circuit,” “module” or “system.” Furthermore, the present invention may take the form of a computer program product embodied in any tangible medium of expression having computer usable program code embodied in the medium.

[0020] Any combination of one or more computer usable or computer readable medium(s) may be utilized. The computer-usable or computer-readable medium may be, for example but not limited to, an electronic, magnetic, optical, electromagnetic, infrared, or semiconductor system, apparatus, device, or propagation medium. More specific examples (a non-exhaustive list) of the computer-readable medium would include the following: an electrical connection having one or more wires, a portable computer diskette, a hard disk, a random access memory (RAM), a read-only memory (ROM), an erasable programmable read-only memory (EPROM or Flash memory), an optical fiber, a portable compact disc read-only memory (CDROM), an optical storage device, a transmission media such as those supporting the Internet or an intranet, or a magnetic storage device. Note that the computer-usable or computer-readable medium could even be paper or another suitable medium upon which the program is printed, as the program can be electronically captured, via, for instance, optical scanning of the paper or other medium, then compiled, interpreted, or otherwise processed in a suitable manner, if necessary, and then stored in a computer memory. In the context of this document, a computer-usable or computer-readable medium may be any medium that can contain, store, communicate, propagate, or transport the program for use by or in connection with the instruction execution system, apparatus, or device. The computer-usable medium may include a propagated data signal with the computer-usable program code embodied therewith, either in baseband or as part of a carrier wave. The computer usable program code may be transmitted using any appropriate medium, including but not limited to wireless, wireline, optical fiber cable, RF, etc.

[0021] Computer program code for carrying out operations of the present invention may be written in any combination of one or more programming languages, including an object oriented programming language such as Java, Smalltalk, C++ or the like and conventional procedural programming languages, such as the “C” programming language or similar programming languages. The program code may execute entirely on the user’s computer, partly on the user’s computer, as a stand-alone software package, partly on the user’s computer and partly on a remote computer or entirely on the remote computer or server. In the latter scenario, the remote computer may be connected to the user’s computer through any type of network, including a local area network (LAN) or a wide area network (WAN), or the connection may be made to an external computer (for example, through the Internet using an Internet Service Provider).

[0022] The present invention is described below with reference to flowchart illustrations and/or block diagrams of

methods, apparatus (systems) and computer program products according to embodiments of the invention. It will be understood that each block of the flowchart illustrations and/or block diagrams, and combinations of blocks in the flowchart illustrations and/or block diagrams, can be implemented by computer program instructions. These computer program instructions may be provided to a processor of a general purpose computer, special purpose computer, or other programmable data processing apparatus to produce a machine, such that the instructions, which execute via the processor of the computer or other programmable data processing apparatus, create means for implementing the functions/acts specified in the flowchart and/or block diagram block or blocks.

[0023] These computer program instructions may also be stored in a computer-readable medium that can direct a computer or other programmable data processing apparatus to function in a particular manner, such that the instructions stored in the computer-readable medium produce an article of manufacture including instruction means which implement the function/act specified in the flowchart and/or block diagram block or blocks.

[0024] The computer program instructions may also be loaded onto a computer or other programmable data processing apparatus to cause a series of operational steps to be performed on the computer or other programmable apparatus to produce a computer implemented process such that the instructions which execute on the computer or other programmable apparatus provide processes for implementing the functions/acts specified in the flowchart and/or block diagram block or blocks.

[0025] A data processing system suitable for storing and/or executing program code will include at least one processor coupled directly or indirectly to memory elements through a system bus. The memory elements can include local memory employed during actual execution of the program code, bulk storage, and cache memories which provide temporary storage of at least some program code in order to reduce the number of times code must be retrieved from bulk storage during execution.

[0026] Input/output or I/O devices (including but not limited to keyboards, displays, pointing devices, etc.) can be coupled to the system either directly or through intervening I/O controllers. Network adapters may also be coupled to the system to enable the data processing system to become coupled to other data processing systems or remote printers or storage devices through intervening private or public networks. Modems, cable modems and Ethernet cards are just a few of the currently available types of network adapters.

[0027] Referring now to the drawings, FIG. 1 is a high-level block diagram illustrating certain components of a system 100 for improved photorealistic imaging workload distribution, in accordance with a preferred embodiment of the present invention. System 100 comprises a graphics client 110.

[0028] Graphics client 110 is a graphics client module or device, as described in more detail in conjunction with FIG. 2, below. Graphics client 110 couples to display 120. Display 120 is an otherwise conventional display, configured to display digitized graphical images to a user.

[0029] Graphics client 110 also couples to a user interface 130. User interface 130 is an otherwise conventional user interface, configured to send information to, and receive information from, a user 132. In one embodiment, graphics

client **110** receives user input from user interface **130**. In one embodiment, user input comprises a plurality of image frames, each frame comprising scene model data, the scene model data describing objects arranged in an image. In one embodiment, user input also comprises camera movement commands describing perspective (or “eye”) movement from one image frame to another.

[0030] In the illustrated embodiment, graphics client **110** also couples to network **140**. Network **140** is an otherwise conventional network. In one embodiment, network **140** is a gigabit Ethernet network. In an alternate embodiment, network **140** is an Infiniband network.

[0031] Network **140** couples to a plurality of compute servers **150**. Each compute server **150** is a compute server as described in more detail in conjunction with FIG. 3, below. In the illustrated embodiment, graphics client **110** couples to the compute servers **150** through network **140**.

[0032] In an alternate embodiment, graphics client **110** couples to one or more computer servers **150** through a direct link **152**. In one embodiment, link **152** is a direct physical link. In an alternate embodiment, link **152** is a virtual link, such as a virtual private network (VPN) link, for example.

[0033] Generally, in an exemplary operation, described in more detail below, system **100** operates as follows. User **132**, through user interface **130**, directs graphics client **110** to display a series of images on display **120**. Graphics client **110** receives the series of images as a series of digitized image “frames,” for example, by retrieving the series of frames from a storage on graphics client **110** or from user interface **130**. Generally, each frame comprises scene model data describing elements arranged in a scene.

[0034] For each frame, graphics client **110** partitions the frame into a plurality of server bands, each server band associated with a particular compute server **150**, based on a server load balancing factor and a prospective rendering factor. Graphics client **110** distributes the server bands to the compute servers **150**. Each compute server **150** (comprising a plurality of processing elements (PEs)) divides the received server bands (received as “raw display bands”) into PE blocks, each PE block associated with a particular PE, based on a PE load balancing factor. In some embodiments, the compute servers **150** divide the server bands into PE blocks based on the PE load balancing factor and prospective rendering information received from the graphics client **110**. The compute servers **150** distribute the PE blocks to their PEs.

[0035] The PEs process the PE blocks, rendering the raw frame data and performing the computationally intensive work of turning the raw frame data into a form suitable for the target display **120**. In photorealistic imaging processing, rendering can include ray tracing, ambient occlusion, and other techniques. The PEs return the processed PE blocks to their parent compute server **150**, which assembles the processed PE blocks into a processed display band.

[0036] In some embodiments, the compute servers **150** compress the processed display bands for transmission to graphics client **110**. In some embodiments, one or more compute servers **150** transmit the processed display bands without additional compression. Each compute server **150** determines the time each of its PEs took to render its PE block and the total rendering time for the entire raw display band.

[0037] The compute servers **150** adjust their PE load balancing factor based on the individual rendering times for each PE. In one embodiment, each compute server **150** also reports its total rendering time to graphics client **110**.

[0038] Graphics client **110** receives the processed display bands and assembles the bands into a processed frame. Graphics client **110** transmits the processed frame to display **120** for display to the user. In one embodiment, graphics client **110** modifies the load balancing factor based on reported rendering times received from the compute servers **150**.

[0039] Thus, as described generally above and in more detail below, graphics client **110** distributes unprocessed server bands to compute servers **150** based in part on the relative load between the servers and in part on prospective rendering information received from the user. The compute servers **150** divide the unprocessed server bands into PE blocks based on the relative load between the PE blocks and the prospective rendering information. The PEs process the blocks, which the compute servers **150** combine into processed bands and return to the graphics client **110**. Graphics client **110** assembles the received processed bands into a form suitable for display to a user. Both the compute servers **150** and graphics client **110** use rendering times to adjust load balancing factors dynamically.

[0040] As such, system **100** can dynamically distribute the workload among the elements performing computationally intensive tasks. As the frame data changes, certain portions of the frame become more computationally intensive than others, and the system can respond by reapportioning the tasks so as to keep the response times roughly equivalent. As one skilled in the art will understand, roughly equivalent response times indicate a balanced load and help to reduce idle time for the PEs/servers.

[0041] FIG. 2 is a block diagram illustrating an exemplary graphics client **200** in accordance with one embodiment of the present invention. In particular, client **200** includes control processing unit (PU) **202**. Control PU **202** is an otherwise conventional processing unit, configured as described herein. In one embodiment, client **200** is a PlayStation3™ (PS3). In an alternate embodiment, client **200** is an x86 machine. In an alternate embodiment, client **200** is a thin client.

[0042] Client **200** also includes load balancing module **204**. Generally, control PU **202** and load balancing module **204** partition a graphics image frame into a plurality of bands based on a server load balancing factor and a prospective rendering factor. In particular, in one embodiment, load balancing module **204** is configured to set and modify a server load balancing factor based on server response times and user input. In one embodiment, user input comprises manual server load balancing settings.

[0043] In one embodiment, load balancing module **204** divides the frame into bands comprising the frame data, and system **200** transmits the divided frame data to the compute servers for rendering. In an alternate embodiment, client **200** transmits coordinate information demarcating the boundaries of each band in the frame. In one embodiment, the coordinate information comprises coordinates referring to a cached (and commonly accessible) frame.

[0044] Load balancing module **204** is also configured to set and modify a prospective rendering factor based on scene model data, user input, and server response times. In one embodiment, user input comprises camera motion information. In one embodiment, camera motion information comprises a perspective, or camera “eye”, and a movement vector indicating the speed and direction of a change in perspective.

[0045] For example, in one embodiment, client **200** accepts user input including camera motion information and is there-

fore aware of the direction and speed of the eye's motion. In an alternate embodiment, client **200** accepts user input including tracking information for a human user's eye movement, substituting the human user's eye movement for a camera eye movement. As such, load balancing module **204** can adjust the server band partitioning in advance, based on the expected change in computational load across the frame.

[0046] That is, one skilled in the art will understand that certain parts of the frame are more computationally intensive than other parts. For example, a frame segment consisting of only a solid, single-color background is much less computationally intensive than a frame segment containing a disco ball reflecting light from multiple sources. Thus, for example, load balancing module **204** could divide the frame into three bands, one band comprising one-half of the disco ball, and two bands each comprising the entire background and one-quarter of the disco ball.

[0047] Further, when the camera eye changes, the scene elements in the frame (e.g., the disco ball) occupy more or less of the frame, in a different location of the frame. In one embodiment, the camera eye movement information includes the direction and velocity of the camera or human eye change, as a "tracking vector." In an alternate embodiment, the camera eye movement information includes a target scene object, upon which the camera eye is focused, and the target scene object's relative distance from the current perspective point. That is, if the system is aware of a specific object that is the focus of the user's attention, a "target scene object," the system can predict that the scene will shift to move that specific object toward the center or near-center of the viewing window. If, for example, the target scene object is located upward and rightward of the current perspective, the camera eye, and therefore the scene, will likely next shift upward and rightward, and the load balancing module can optimize the server band partitioning for that tracking vector.

[0048] As such, in one embodiment, load balancing module **204** uses the camera eye movement information and the scene model data to adjust the server band partitioning in advance, which tends to equalize the computational load across the compute servers. In one embodiment, load balancing module **204** uses the tracking vector, target scene object, and relative distance to determine the magnitude of the server band partitioning adjustments. In one embodiment, the magnitude of the server band partitioning adjustments is a measure of the "aggressiveness" of a server band partitioning.

[0049] Generally, having partitioned the frame into server bands, client **200** distributes the server bands to their assigned compute servers. Client **200** receives processed display bands from the compute servers in return. In one embodiment, client **200** determines the response time for each compute server. In an alternate embodiment, client **200** receives reported response times from each compute server.

[0050] Client **200** also includes cache **206**. Cache **206** is an otherwise conventional cache. Generally, client **200** stores processed and unprocessed frames, and other information, in cache **206**.

[0051] Client **200** also includes decompressor **208**. In one embodiment, client **200** receives compressed processed server bands from the compute servers. As such, decompressor **208** is configured to decompress compressed processed server bands.

[0052] Client **200** also includes display interface **210**, user interface **212**, and network interface **214**. Display interface **210** is an otherwise conventional display interface, configured to interface with a display, such as display **120** of FIG. 1, for example. User interface **212** is an otherwise conventional user interface, configured, for example, as user interface **130**

of FIG. 1. Network interface **214** is an otherwise conventional network interface, configured to interface with a network, such as network **140** of FIG. 1, for example.

[0053] As described above, client **200** is a graphics client, such as graphics client **110** of FIG. 1, for example. Accordingly, client **200** transmits raw server bands to computer servers for rendering and receives processed display bands for display. FIG. 3 illustrates an exemplary compute server in accordance with one embodiment of the present invention.

[0054] In particular, FIG. 3 is a block diagram illustrating an exemplary compute server **300** in accordance with one embodiment of the present invention. In particular, server **300** includes control processing unit (PU) **302**. As illustrated, control PU **302** is an otherwise conventional processing unit, configured to operate as described below.

[0055] Server **300** also includes a plurality of processing elements (PEs) **310**. Generally, each PE **310** is an otherwise conventional PE, configured with a local store **312**. As described in more detail below, each PE **310** receives a PE block for rendering, renders the PE block, and returns a rendered PE block to the control PU **302**.

[0056] Server **300** also includes load balancing module **304**. Generally, control PU **302** and load balancing module **304** partition a received raw display band into a plurality of PE blocks based on a PE load balancing factor. In particular, in one embodiment, load balancing module **304** is configured to set and modify a PE load balancing factor based on PE response times. In an alternate embodiment, the PE load balancing factor includes a prospective rendering factor, and load balancing module **304** is configured to modify the PE load balancing factor based on PE response times and user input.

[0057] In one embodiment, load balancing module **304** divides the received raw display band into PE blocks comprising the frame data and control PU **302** transmits the divided frame data to the PEs for rendering. In an alternate embodiment, control PU **302** transmits coordinate information demarcating the boundaries of each PE block. In one embodiment, the coordinate information comprises coordinates referring to a cached (and commonly accessible) frame.

[0058] Generally, having partitioned the raw display bands into PE blocks, server **300** distributes the PE blocks their assigned PEs. The PEs **310** render their received PE blocks and return rendered PE blocks to control PU **302**. In one embodiment, each PE **310** stores a rendered PE block in cache **306** and indicates to control PU **302** that the PE has completed rendering its PE block.

[0059] As such, server **300** also includes cache **306**. Cache **306** is an otherwise conventional cache. Generally, server **300** stores processed and unprocessed bands, PE blocks, and other information, in cache **306**.

[0060] Server **300** also includes compressor **308**. In one embodiment, the graphics client receives compressed processed server bands from the compute servers. As such, compressor **308** is configured to compress processed display bands for transmission to the graphics client.

[0061] Server **300** also includes network interface **314**. Network interface **314** is an otherwise conventional network interface, configured to interface with a network, such as network **140** of FIG. 1, for example.

[0062] Generally, server **300** receives raw display bands from a graphics client. Control PU **302** and load balancing module **304** divide the received display band into PE blocks based on a PE load balancing factor. The PEs **310** render their assigned blocks and control PU **302** assembles the rendered PE blocks into a processed display band. Compressor **308**

compresses the processed display band and server 300 transmits the processed display band to the graphics client.

[0063] In one embodiment, control PU 302 adjusts the PE load balancing factor based on the rendering times for each PE 310. In one embodiment, control PU 302 also determines a total rendering time for the entire display band and reports the total rendering time to the graphics client. Thus, generally, server 300 can modify the PE load balancing factor to adapt to changing loads on the PEs.

[0064] Thus, server 300 can balance the rendering load between the PEs, which in turn helps improve (minimize) response time. The operation of the graphics client and the compute server are described in additional detail below. More particularly, the operation of an exemplary graphics client is described with respect to FIG. 4, and the operation of an exemplary compute server is described with respect to FIG. 5.

[0065] FIG. 4 illustrates one embodiment of a method for photorealistic imaging workload distribution. Specifically, FIG. 4 illustrates a high-level flow chart 400 that depicts logical operational steps performed by, for example, system 200 of FIG. 2, which may be implemented in accordance with a preferred embodiment. Generally, control PU 202 performs the steps of the method, unless indicated otherwise.

[0066] As indicated at block 405, the process begins, wherein system 200 receives a digital graphic image frame comprising scene model data for display. For example, system 200 can receive a frame from a user or other input. Next, as illustrated at block 410, system 200 receives user input. As described above, in one embodiment, user input includes camera movement information.

[0067] Next, as illustrated at block 415, system 200 sets or modifies a server load balancing factor based on the received frame. Next, as illustrated at block 420, system 200 sets or modifies a prospective rendering factor based on received user input and scene model data. Next, as illustrated at block 425, system 200 partitions the frame into server bands based on the server load balancing factor and the prospective rendering factor.

[0068] Based on the user input and the prospective rendering factor, system 200 is aware of the direction and speed of the camera eye's motion. As such, system 200 can pre-adjust the server workload without having to rely exclusively on reactive adjustments. For example, if the user "looks" up or down (moving the camera eye vertically), system 200 can decrease the size of the regions of the compute server on the leading edge to account for the new model geometry that is about to be introduced into the scene.

[0069] Moreover, system 200 can adjust how aggressively to rebalance the workload based on the speed of the eye motion. If the camera eye is moving more quickly, system 200 can adjust the workload more aggressively. If the camera eye is moving more slowly, system 200 can adjust the workload less aggressively.

[0070] Additionally, system 200 can tailor workload rebalancing according to the type of eye movement demonstrated by the user input. That is, certain types of eye movement respond best to different adjustment patterns. For example, zooming in or moving along the eye vector leads to less of an imbalance across compute servers. As such, system 200 can adjust the workload less aggressively in response to a rapid zoom function, for example, than in response to a rapid pan function.

[0071] In one embodiment, system 200 partitions the frame into horizontal server bands. In an alternate embodiment, system 200 partitions the frame into vertical server bands. In an alternate embodiment, system 200 partitions the frame into

horizontal or vertical server bands, depending on which alignment yields the more effective (load balancing) partitioning.

[0072] Next, as illustrated at block 430, system 200 distributes the server bands to compute servers. Next, as illustrated at block 435, system 200 receives compressed processed display bands from the compute servers. Next, as illustrated at block 440, system 200 decompresses the received compressed processed display bands.

[0073] Next, as illustrated at block 445, system 200 assembles a processed frame based on the processed display bands. Next, as illustrated at block 450, system 200 stores the processed frame. Next, as illustrated at block 455, system 200 displays an image based on the processed frame. As described above, in one embodiment, system 200 transmits the processed frame to a display module for display.

[0074] Next, as illustrated at block 460, system 200 receives reported rendering times from the compute servers. Next, as illustrated at block 465, system 200 modifies the server load balancing based on the reported rendering times. The process returns to block 405, wherein the graphics client receives a frame for processing.

[0075] FIG. 5 illustrates one embodiment of a method for photorealistic imaging workload distribution. Specifically, FIG. 5 illustrates a high-level flow chart 500 that depicts logical operational steps performed by, for example, system 300 of FIG. 3, which may be implemented in accordance with a preferred embodiment. Generally, compute PU 302 performs the steps of the method, unless indicated otherwise.

[0076] As illustrated at block 505, the process begins, wherein a compute server receives a raw display band from a graphics client. For example, system 300 of FIG. 3 receives a raw display band from a graphics client 200 of FIG. 2. Next, as illustrated at block 510, system 300 partitions the raw display band into PE blocks based on a PE load balancing factor.

[0077] In one embodiment, the raw display band includes camera movement information and system 300 partitions the raw display band into PE blocks based on a PE load balancing factor and the camera movement information. In one embodiment, system 300 partitions the raw display band in a similar fashion as does system 200 as described with respect to block 425, above. Accordingly, system 300 can dynamically partition the raw display band to account for prospective changes in the composition of the frame image, helping to maintain load balance between the PEs.

[0078] Next, as illustrated at block 515, system 300 distributes the PE blocks to the processing elements. For example, control PU 302 distributes the PE blocks to one or more PEs 310. Next, as illustrated at block 520, each PE renders its received PE block. For example, the PEs 310 render their received PE blocks.

[0079] Next, as illustrated at block 525, control PU 302 receives the rendered PE blocks from the PEs 310. As described above, in one embodiment, control PU 302 receives a notification from the PEs 310 that the rendered blocks are available in cache 306. Next, as illustrated at block 530, system 300 combines the rendered PE blocks into a processed display band.

[0080] Next, as illustrated at block 535, system 300 compresses the processed display band for transmission to the graphics client. For example, compressor 308 compresses the processed display band for transmission to the graphics client. Next, as illustrated at block 540, system 300 transmits the compressed display band to the graphics client.

[0081] Next, as illustrated at block 545, system 300 determines a render time for each PE. For example, control PU 302

determines a render time for each PE **310**. Next, as illustrated at block **545**, system **300** reports the rendering time to the graphics client. In one embodiment, system **300** calculates the total rendering time for the processed display band, based on the slowest PE, and reports the total rendering time to the graphics client. In an alternate embodiment, system **300** reports the rendering time for each PE to the graphics client.

[0082] Next, as illustrated at block **555**, system **300** adjusts the PE load balancing factor based on the rendering time for each PE. As described above, system **300** can set the PE load balancing factor to divide the workload among the PEs such that each PE takes approximately the same amount of time to complete its rendering task.

[0083] Accordingly, the disclosed embodiments provide numerous advantages over other methods and systems. For example, the disclosed embodiments improve balanced workload distribution over current approaches, especially work-stealing systems. Because the disclosed embodiments better distribute the computational workload, work-stealing is unnecessary, and the computational units can retain relevant cache data without also incurring the penalties inherent in re-tasking a processing element under common work-stealing schema.

[0084] More specifically, the disclosed embodiments provide the balance of photorealistic imaging workload distribution, especially in ray tracing applications. By actively managing the computationally intensive regions of a frame, and stalling the computational units waiting for the next frame, the rendering system spends less time stalled for data.

[0085] Further, the disclosed embodiments offer methods that maintain focus of a computational unit on a particular region, even as that region is expanded or reduced to maintain relative workload. As such, any particular computational unit is more likely to retain useful frame data in its cache, which improves cache hit rates. Moreover, the improved cache hit rates overcome the slightly increased intra-frame stalls, improving the overall rendering time.

[0086] Additionally, the disclosed embodiments provide a system and method that dynamically adjusts the workload based on prospective rendering tasking. As such, the disclosed embodiments can reduce the performance impact of a rapidly moving camera eye by anticipating changes in the computational intensity of regions in the scene. Other technical advantages will be apparent to one of ordinary skill in the relevant arts.

[0087] As described above, one or more embodiments described herein may be practiced or otherwise embodied in a computer system. Generally, the term "computer," as used herein, refers to any automated computing machinery. The term "computer" therefore includes not only general purpose computers such as laptops, personal computers, minicomputers, and mainframes, but also devices such as personal digital assistants (PDAs), network enabled handheld devices, internet or network enabled mobile telephones, and other suitable devices. FIG. 6 is a block diagram providing details illustrating an exemplary computer system employable to practice one or more of the embodiments described herein.

[0088] Specifically, FIG. 6 illustrates a computer system **600**. Computer system **600** includes computer **602**. Computer **602** is an otherwise conventional computer and includes at least one processor **610**. Processor **610** is an otherwise conventional computer processor and can comprise a single-core, dual-core, central processing unit (PU), synergistic PU, attached PU, or other suitable processors.

[0089] Processor **610** couples to system bus **612**. Bus **612** is an otherwise conventional system bus. As illustrated, the various components of computer **602** couple to bus **612**. For

example, computer **602** also includes memory **620**, which couples to processor **610** through bus **612**. Memory **620** is an otherwise conventional computer main memory, and can comprise, for example, random access memory (RAM). Generally, memory **620** stores applications **622**, an operating system **624**, and access functions **626**.

[0090] Generally, applications **622** are otherwise conventional software program applications, and can comprise any number of typical programs, as well as computer programs incorporating one or more embodiments of the present invention. Operating system **624** is an otherwise conventional operating system, and can include, for example, Unix, AIX, Linux, Microsoft Windows™, MacOS™, and other suitable operating systems. Access functions **626** are otherwise conventional access functions, including networking functions, and can be include in operating system **624**.

[0091] Computer **602** also includes storage **630**. Generally, storage **630** is an otherwise conventional device and/or devices for storing data. As illustrated, storage **630** can comprise a hard disk **632**, flash or other volatile memory **634**, and/or optical storage devices **636**. One skilled in the art will understand that other storage media can also be employed.

[0092] An I/O interface **640** also couples to bus **612**. I/O interface **640** is an otherwise conventional interface. As illustrated, I/O interface **640** couples to devices external to computer **602**. In particular, I/O interface **640** couples to user input device **642** and display device **644**. Input device **642** is an otherwise conventional input device and can include, for example, mice, keyboards, numeric keypads, touch sensitive screens, microphones, webcams, and other suitable input devices. Display device **644** is an otherwise conventional display device and can include, for example, monitors, LCD displays, GUI screens, text screens, touch sensitive screens, Braille displays, and other suitable display devices.

[0093] A network adapter **650** also couples to bus **612**. Network adapter **650** is an otherwise conventional network adapter, and can comprise, for example, a wireless, Ethernet, LAN, WAN, or other suitable adapter. As illustrated, network adapter **650** can couple computer **602** to other computers and devices **652**. Other computers and devices **652** are otherwise conventional computers and devices typically employed in a networking environment. One skilled in the art will understand that there are many other networking configurations suitable for computer **602** and computer system **600**.

[0094] The flowchart and block diagrams in the Figures illustrate the architecture, functionality, and operation of possible implementations of systems, methods and computer program products according to various embodiments of the present invention. In this regard, each block in the flowchart or block diagrams may represent a module, segment, or portion of code, which comprises one or more executable instructions for implementing the specified logical function (s). It should also be noted that, in some alternative implementations, the functions noted in the block may occur out of the order noted in the figures. For example, two blocks shown in succession may, in fact, be executed substantially concurrently, or the blocks may sometimes be executed in the reverse order, depending upon the functionality involved. It will also be noted that each block of the block diagrams and/or flowchart illustration, and combinations of blocks in the block diagrams and/or flowchart illustration, can be implemented by special purpose hardware-based systems that perform the specified functions or acts, or combinations of special purpose hardware and computer instructions.

[0095] One skilled in the art will appreciate that variations of the above-disclosed and other features and functions, or alternatives thereof, may be desirably combined into many

other different systems or applications. Additionally, various presently unforeseen or unanticipated alternatives, modifications, variations or improvements therein may be subsequently made by those skilled in the art, which are also intended to be encompassed by the following claims.

What is claimed is:

1. A method, comprising:
 - receiving, by a graphics client, a frame, the frame comprising scene model data;
 - setting a server load balancing factor based on the scene model data;
 - setting a prospective rendering factor based on the scene model data;
 - partitioning the frame into a plurality of server bands based on the server load balancing factor and the prospective rendering factor;
 - distributing the plurality of server bands to a plurality of compute servers;
 - receiving processed server bands from the plurality of compute servers;
 - assembling a processed frame based on the received processed server bands; and
 - transmitting the processed frame for display to a user as an image.
2. The method of claim 1, further comprising:
 - receiving user input; and
 - wherein setting the prospective rendering factor further comprises setting the prospective rendering factor based on the scene model data and received user input.
3. The method of claim 1, wherein partitioning the frame further comprises selecting between horizontal server bands and vertical server bands.
4. The method of claim 1, further comprising:
 - receiving reported rendering times from at least one of the plurality of servers; and
 - wherein setting the server load balancing factor further comprises setting the server load balancing factor based on the scene model data and the reported rendering times.
5. The method of claim 1, wherein assembling a processed frame band further comprises decompressing the received processed server bands.
6. A computer program product for processing a digitized graphic frame, the computer program product stored on a computer usable medium having computer usable program code embodied therewith, the computer useable program code comprising:
 - computer usable program code configured to receive a frame, the frame comprising scene model data;
 - computer usable program code configured to set a server load balancing factor based on the scene model data;
 - computer usable program code configured to set a prospective rendering factor based on the scene model data;
 - computer usable program code configured to partition the frame into a plurality of server bands based on the server load balancing factor and the prospective rendering factor;
 - computer usable program code configured to distribute the plurality of server bands to a plurality of compute servers;
 - computer usable program code configured to receive processed server bands from the plurality of compute servers;

computer usable program code configured to assemble a processed frame based on the received processed server bands; and

computer usable program code configured to transmit the processed frame for display to a user as an image.

7. The computer program product of claim 6, further comprising:

computer usable program code configured to receive user input; and

wherein setting the prospective rendering factor further comprises setting the prospective rendering factor based on the scene model data and received user input.

8. The computer program product of claim 6, wherein partitioning the frame further comprises selecting between horizontal server bands and vertical server bands.

9. The computer program product of claim 6, further comprising:

computer usable program code configured to receiving reported rendering times from at least one of the plurality of servers; and

wherein setting the server load balancing factor further comprises setting the server load balancing factor based on the scene model data and the reported rendering times.

10. The computer program product of claim 1, wherein assembling a processed frame band further comprises decompressing the received processed server bands.

11. A method, comprising:

receiving, by a compute server, a raw display band, the raw display band comprising scene model data;

the compute server comprising a plurality of processing elements (PEs);

partitioning the raw display band into a plurality of PE blocks based on a PE load balancing factor;

distributing the plurality of PE blocks to the plurality of PEs;

rendering, by each PE, the PE blocks, to generate rendered PE blocks;

combining, by the compute server, the rendered PE blocks, to generate a processed display band;

determining, by the compute server, a rendering time for each PE;

modifying the PE load balancing factor based on the determined rendering times; and

transmitting the processed display band to a graphics client.

12. The method of claim 11, wherein transmitting comprises compressing the processed display band.

13. The method of claim 11, further comprising reporting a rendering time to the graphics client based on the determined rendering times.

14. The method of claim 11, further comprising:

wherein the raw display band further comprises prospective rendering input; and

wherein partitioning the raw display band comprises partitioning based on the PE load balancing factor and the prospective rendering input.

15. The method of claim 11, wherein modifying the PE load balancing factor further comprises modifying the PE load balancing factor based on the determined rendering times and received prospective rendering input.

16. A computer program product for processing a digitized graphic frame, the computer program product stored on a

computer usable medium having computer usable program code embodied therewith, the computer useable program code comprising:

- computer usable program code configured to receive a raw display band, the raw display band comprising scene model data;
- computer usable program code configured to partition the raw display band into a plurality of PE blocks based on a PE load balancing factor;
- computer usable program code configured to distribute the plurality of PE blocks to a plurality of PEs;
- computer usable program code configured to render, by each PE, the PE blocks, to generate rendered PE blocks;
- computer usable program code configured to combine the rendered PE blocks, to generate a processed display band;
- computer usable program code configured to determine a rendering time for each PE;
- computer usable program code configured to modify the PE load balancing factor based on the determined rendering times; and
- computer usable program code configured to transmit the processed display band to a graphics client.

17. The computer program product of claim 16, wherein transmitting comprises compressing the processed display band.

18. The computer program product of claim 16, further comprising computer usable program code configured to report a rendering time to the graphics client based on the determined rendering times.

19. The computer program product of claim 16, further comprising:

- wherein the raw display band further comprises prospective rendering input; and
- wherein partitioning the raw display band comprises partitioning based on the PE load balancing factor and the prospective rendering input.

20. The computer program product of claim 16, wherein modifying the PE load balancing factor further comprises modifying the PE load balancing factor based on the determined rendering times and received prospective rendering input.

21. A system comprising a graphics client, the graphics client configured to:

- receive a frame, the frame comprising scene model data;
- set a server load balancing factor based on the scene model data;
- set a prospective rendering factor based on the scene model data;
- partition the frame into a plurality of server bands based on the server load balancing factor and the prospective rendering factor;

distribute the plurality of server bands to a plurality of compute servers;
receive processed server bands from the plurality of compute servers;
assemble a processed frame based on the received processed server bands; and
transmit the processed frame for display to a user as an image.

22. The system of claim 21, further comprising:
wherein the graphics client is further configured to receive user input; and
wherein setting the prospective rendering factor further comprises setting the prospective rendering factor based on the scene model data and received user input.

23. The system of claim 21, further comprising:
wherein the graphics client is further configured to receive reported rendering times from at least one of the plurality of servers; and
wherein setting the server load balancing factor further comprises setting the server load balancing factor based on the scene model data and the reported rendering times.

24. The system of claim 21, further comprising:
a plurality of compute servers, each compute server coupled to the graphics client and comprising a plurality of processing elements (PEs), and each compute server configured to:

- receive a raw display band from the graphics client, the raw display band comprising scene model data;
- partition the raw display band into a plurality of PE blocks based on a PE load balancing factor; and
- distribute the plurality of PE blocks to the plurality of PEs;

wherein each PE is configured to render the PE blocks, to generate rendered PE blocks; and

wherein each compute server is further configured to:
combine the rendered PE blocks rendered by that compute server's PEs, to generate a processed display band;
determine a rendering time for each of that compute server's PEs;
modify the PE load balancing factor based on the determined rendering times; and
transmit the processed display band to the graphics client.

25. The system of claim 24, further comprising:
wherein the raw display band further comprises prospective rendering input; and
wherein partitioning the raw display band comprises partitioning based on the PE load balancing factor and the prospective rendering input.

* * * * *