

H. I. OWEN.  
LOCKING DEVICE.  
APPLICATION FILED APR. 20, 1910.

1,000,936.

Patented Aug. 15, 1911.

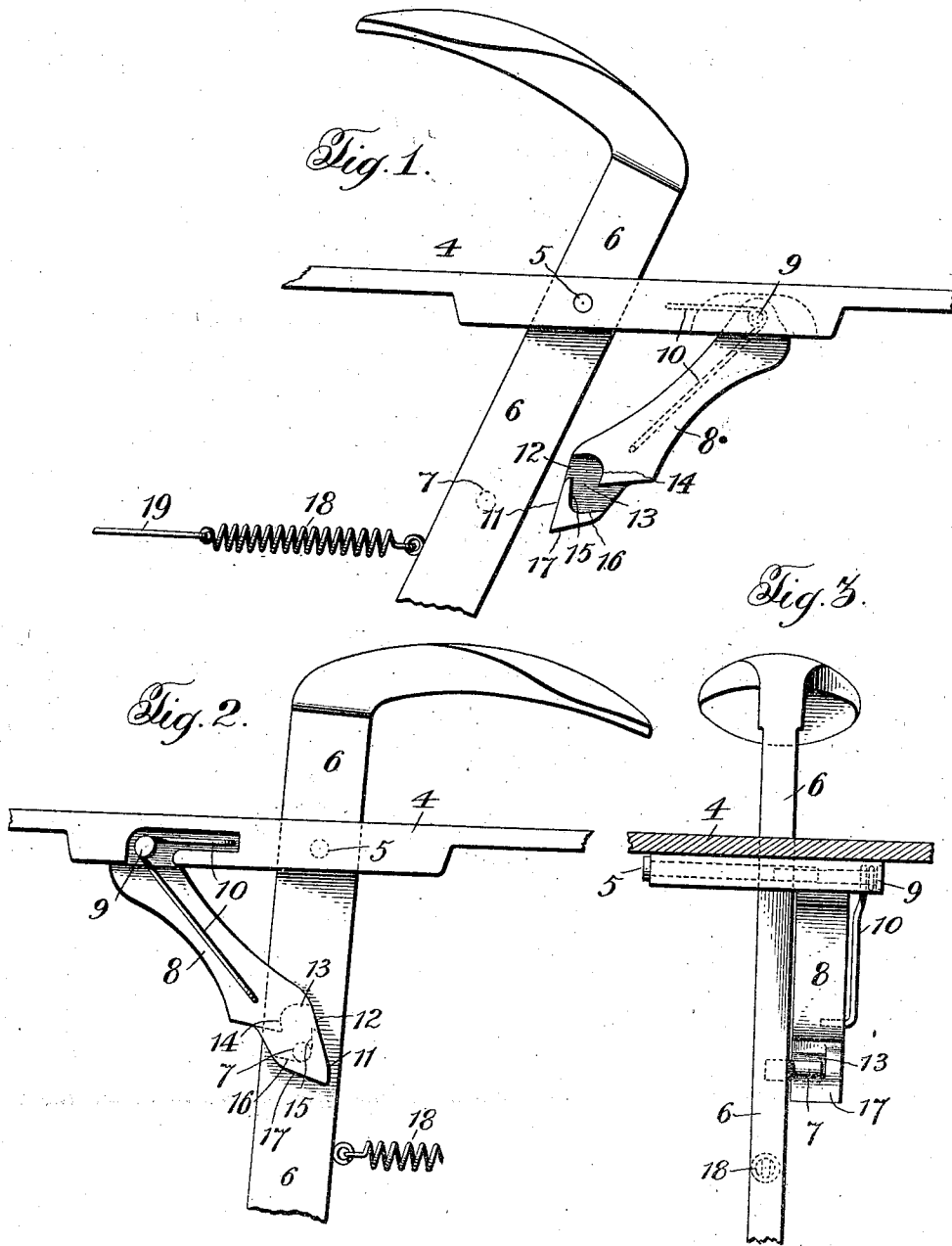

Witnesses:

James Hutchinson  
Edwin Daly

Inventor:

Henry I. Owen,  
By Royal E. Burnham, Attorney.

# UNITED STATES PATENT OFFICE.

HENRY I. OWEN, OF FULTON, MISSOURI.

## LOCKING DEVICE.

1,000,936.

Specification of Letters Patent. Patented Aug. 15, 1911.

Application filed April 20, 1910. Serial No. 556,556.

### To all whom it may concern:

Be it known that I, HENRY I. OWEN, a citizen of the United States, residing at Fulton, in the county of Callaway and State of Missouri, have invented certain new and useful Improvements in Locking Devices, of which the following is a specification, reference being had therein to the accompanying drawing.

This invention provides a catch or ratchet for holding a lever or other movable element in locked position against tension. Among other things, it is suitable for use in connection with levers used on motor-vehicles for controlling various parts thereof.

It is an object of the invention to provide a catch or ratchet which will operate to automatically lock a lever or other element when the latter is moved to maintain some part connected therewith, as for example a cut-out valve of a motor-vehicle, in a desired position or condition, and which will automatically release when a motion is given the lever or other element similar to that imparted in bringing it to locked position.

When read in connection with the description herein, the details of construction and arrangement of parts contemplated by this invention will be apparent from the accompanying drawings, forming part hereof, wherein an embodiment of the invention as applied to a foot-lever of a motor-vehicle is disclosed, for purposes of illustration. It is to be understood, however, that the invention is susceptible of use with various other devices, that the several instrumentalities of which the invention consists can be variously organized without departing from the nature and spirit of the invention, and that the invention is not to be necessarily limited in the interpretation of the claims hereinafter to the precise delineation herein.

Like reference-characters refer to corresponding parts in the views of the drawings, of which—

Figure 1 is a view of one side; Fig. 2 is a view of the opposite side; and Fig. 3 is a front view.

Referring more particularly to the drawings, 4 designates a base or plate, wherein is fulcrumed, as at 5, a lever 6 of a controlling mechanism. A pin or projection 7 extends from the lever in a direction transverse to the line of its movement at a place removed from the fulcrum.

A catch 8 is pivoted in the base or plate

near the lever, as at 9, in the plane of movement of pin 7. A spring 10 normally holds the free end of the catch in a position to be properly engaged by pin 7, in a manner hereinafter described, and so that the catch may be moved in either direction on its pivot. The catch has a surface 11, on the side normally toward the pin, which extends from its end to an entrance 12 of a slot 13 formed in the face of the catch adjacent to the lever. Slot 13, extends inwardly and downwardly from its entrance and then to the side opposite to surface 11 with a slight upward inclination, whereby are formed a stop-wall 14 opposite to the entrance, a locking-wall 15 below the entrance, and an upwardly-inclined release-wall 16 extending from the wall 15 to the side of the catch. A beveled surface 17 extends from the end of the slot opposite to the entrance to the end of the catch where it meets surface 11. The spring 10 is so tensioned as to normally maintain the catch in such position that the pin 7 will contact surface 11 when the lever is moved in direction to be locked. When the pin, in its movement in contact with this surface, reaches the entrance 12, the spring will move the catch so that it will come in contact with both the locking-wall 15 and the release-wall 16, the release-wall preventing further upward movement of the catch and consequent disengagement of the pin therefrom. The lever is given tendency to move away from the catch by a spring 18 or its equivalent, forming part of an operating-rod 19 of a controlling mechanism or attached to some fixed part, as desired.

When the operator wishes to throw the lever to locked position to maintain a part, for example, controlled by rod 19 in a desired position or condition, he moves the lever in direction of the catch. Then the pin will engage surface 11 and move the catch until the pin enters the slot, whereupon spring 10 moves the catch back toward its normal position and locking-wall 15 into engagement with the pin, by which engagement the lever is held in locked position against movement away from the catch and at which time the operator may release pressure on the lever. Continuance of movement of the lever in direction given to bring it to locked position is arrested at the proper time by engagement of the pin with stop-wall 14 opposite to the slot-entrance, this

arrest of motion being particularly necessary when the lever is given a quick movement which would tend to pass the pin entirely through the slot, if there was no means of arresting the motion.

To release the lever from locked position, the operator substantially repeats the motion necessary to lock it—that is, he moves the lever in the same direction as required to lock it to bring the pin out of the slot at the end opposite to the entrance. During this movement, the pin engages upwardly-inclined wall 16 which slightly swings the catch in the same direction as engagement with surface 11 until the pin passes out of the slot. When the pin becomes disengaged from the slot, the catch is returned to its normal position by spring 10, when the exit end of the slot is above the pin, and then the lever is free to be returned to its normal unlocked position, the pin during this movement passing the catch by engagement with surface 17 and swinging the catch sufficiently to permit the passage.

It will be seen that a lever, such as controlled by a foot-pedal in a motor-vehicle, can be easily brought to locked position and as easily unlocked by mere pressure on the pedal, in each instance in the same direction, and that double pedals, one for actuation and the other for unlocking, and complicated pedal structures of other forms, such as heretofore used to lock and unlock vehicle-levers, may be dispensed by the use of this invention.

The terms "upper" and "lower" and the like used in describing the locking-catch are merely relative to the particular form and arrangement shown in the drawings, being employed only for convenience of description, and not restricting the invention to the exact position shown.

Having thus described my invention, what I claim as new, and desire to secure by Letters Patent, is—

1. In a controlling mechanism the combination, with a controlling member having a projection thereon, of a catch having a slot open at each end adapted to receive said projection, a spring, a locking-wall in said slot arranged to be moved by said spring into contact with said projection upon its movement into the slot in one direction, and a release-wall arranged to stop relative movement of the parts when the projection and locking-wall are engaged and to permit disengagement thereof upon subsequent movement of said projection in the same direction.

2. In a controlling mechanism, the combination, with a controlling member, of a locking member having a slot open at each end adapted to receive a portion of said controlling member and said slot having surfaces

arranged to be contacted by and to lock said controlling member upon movement of a portion of the latter in one direction into the slot, and means whereby said controlling member is brought into locking engagement with one of said surfaces at one stage of the movement and whereby it is disengaged from said locking member upon continuance of movement of the controlling member in the same direction and out of said slot.

3. In a controlling mechanism, the combination, with a controlling member, of a pivoted catch having a slot open at each end and formed with contact surfaces arranged to lock said controlling member upon movement of a portion thereof in one direction into said slot and into contact with said surfaces, and means whereby said controlling member is brought into locking engagement with one of said surfaces at one stage of the movement and whereby it is disengaged from said catch upon continuance of movement of the controlling member in the same direction and out of the slot.

4. In a controlling mechanism, the combination, with a controlling member, of a projection on said member, a locking member having a slot open at each end and having surfaces arranged to be contacted by and to lock said projection upon movement of the latter in one direction in said slot, and means whereby said projection is brought into locking engagement with one of said surfaces at one stage of the movement and whereby it is disengaged from said slot upon continuance of movement of said controlling member in the same direction.

5. In a controlling mechanism, the combination, with a controlling member having a projection thereon, of a locking member having a slot open at each end and containing a locking-wall, means whereby said projection is brought into contact with said locking-wall upon movement of said controlling member in one direction, and means whereby said projection is released from said locking-wall and from the slot upon a subsequent movement of said controlling member in the same direction.

6. In a controlling mechanism, the combination, with a controlling member having a projection thereon, of a locking member having a slot open at each end arranged to receive said projection and formed with a surface arranged to arrest movement of said projection when it has reached locked position, and means whereby said controlling member is unlocked upon a subsequent movement of said projection in the same direction and out of the slot.

7. In a controlling mechanism, the combination, with a controlling member having a projection thereon, of a catch having a slot open at each end formed with a stop-

wall and a locking-wall arranged for engagement by said projection upon movement of the projection in the slot in one direction, and means whereby said projection is disengaged from said slot upon subsequent movement of the projection in the same direction.

8. In a controlling mechanism, the combination, with a controlling member having a projection thereon, of a catch having a contact-surface thereon and a slot open at each end and having therein a locking-wall, and a spring controlling the movement of said catch, the arrangement being such that on movement of the projection in one direction it engages said contact-surface and then enters said slot and engages said locking-wall and upon subsequent movement of said projection in the same direction it will be disengaged from said wall and from said slot.

9. In a controlling mechanism, the combination, with a controlling member having a projection thereon, of a catch having a slot therein open at each end adapted to receive said projection and forming a locking-wall and a release-wall, and a spring arranged to bring said locking-wall into contact with said projection upon entrance of the latter into said slot in one direction and to move said slot from registry with said

projection upon subsequent movement of said projection in the same direction and in contact with said release-wall and out of the slot.

10. An operating mechanism comprising a lever having a projection thereon, a pivoted catch having a slot extending thereacross and adapted to receive said projection and having therein a locking-wall engageable thereby, and yielding means operating to normally maintain the exit end of said slot out of the path of movement of said projection.

11. An operating mechanism comprising a lever having a projection thereon, a pivoted catch having a slot thereacross and adapted to receive said projection and containing a locking-wall engageable thereby, there being an exterior contact-surface on said catch leading to said slot, and yielding means operating to normally maintain the entrance and exit ends of the slot out of registry with said projection and the contact-surface normally in the path of movement thereof.

In testimony whereof I affix my signature in presence of two witnesses.

HENRY I. OWEN.

Witnesses:

J. W. TINCHER,  
S. P. BEOVEN.